

PCB terminal block - PTSM 0,5/ 4-2,5-V SMD R44 - 1771114

Please be informed that the data shown in this PDF Document is generated from our Online Catalog. Please find the complete data in the user's documentation. Our General Terms of Use for Downloads are valid (<http://phoenixcontact.com/download>)

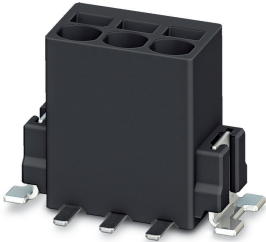

The figure shows a 3-position version

PCB terminal block, nominal current: 6 A, rated voltage (III/2): 160 V, nominal cross section: 0.5 mm², number of potentials: 4, Number of rows: 1, Number of positions per row: 4, product range: PTSM 0,5/..-V-SMD, pitch: 2.5 mm, connection method: Push-in spring connection, mounting: SMD soldering, conductor/PCB connection direction: 90 °, color: black, Pin layout: Linear pad geometry, type of packaging: 44 mm wide tape

Your advantages

- ✓ Time saving push-in connection, tools not required
- ✓ Defined contact force ensures that contact remains stable over the long term
- ✓ High current carrying capacity of 6 A in very compact dimensions
- ✓ Designed for integration into the SMT soldering process
- ✓ Vertical connection enables multi-row arrangement on the PCB
- ✓ Additional solder anchors reduce the mechanical strain on the soldering spots

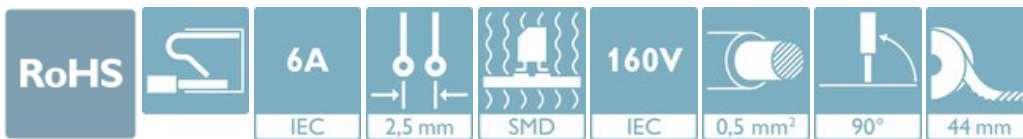

Key Commercial Data

Packing unit	1 pc
Minimum order quantity	400 pc
GTIN	
GTIN	4046356460149
Weight per Piece (excluding packing)	2.450 g
Custom tariff number	85369010
Country of origin	India

Technical data

Item properties

Brief article description	PCB terminal block
---------------------------	--------------------

PCB terminal block - PTSM 0,5/ 4-2,5-V SMD R44 - 1771114

Technical data

Item properties

Range of articles	PTSM 0,5/..-V-SMD
Pitch	2.5 mm
Number of positions	4
Mounting type	SMD soldering
Pin layout	Linear pad geometry
Number of rows	1
Number of connections	4
Number of potentials	4

Electrical parameters

Nominal current	6 A
Nom. voltage	160 V
Rated voltage (III/3)	32 V
Rated voltage (III/2)	160 V
Rated voltage (II/2)	160 V
Rated surge voltage (III/3)	2.5 kV
Rated surge voltage (III/2)	2.5 kV
Rated surge voltage (II/2)	2.5 kV

Connection capacity

Connection method	Push-in spring connection
pluggable	no
Conductor cross section solid	0.14 mm ² ... 0.5 mm ²
Conductor cross section flexible	0.2 mm ² ... 0.5 mm ² (up to 0.75 mm ² supported, with a stripping length of 7.5 mm and a rated insulation voltage of 32 V at III/2)
Conductor cross section AWG / kcmil	26 ... 20
Conductor cross section flexible, with ferrule without plastic sleeve	0.25 mm ² ... 0.5 mm ²
Conductor cross section, flexible, with ferrule, with plastic sleeve	0.25 mm ² ... 0.34 mm ²
Cylindrical gauge a x b / diameter	- / 1.2 mm
Stripping length	6 mm

Material data - contact

Note	WEEE/RoHS-compliant, free of whiskers according to IEC 60068-2-82/ JEDEC JESD 201
Contact material	Cu alloy
Surface characteristics	hot-dip tin-plated
Metal surface terminal point (top layer)	Tin (4 - 8 µm Sn)
Metal surface soldering area (top layer)	Tin (4 - 8 µm Sn)

Material data - housing

PCB terminal block - PTSM 0,5/ 4-2,5-V SMD R44 - 1771114

Technical data

Material data - housing

Housing color	black (9005)
Insulating material	LCP
Insulating material group	IIIa
CTI according to IEC 60112	175
Flammability rating according to UL 94	V0

Dimensions for the product

Caption	Schematische Abbildung - weitere Details siehe Produktfamilienzeichnung im Download Center
Length [l]	7 mm
Width [w]	15.1 mm
Height [h]	9 mm
Pitch	2.5 mm
Height (without solder pin)	9 mm

Dimensions for PCB design

Pad geometry	1.4 x 3.4 mm
--------------	--------------

Packaging information

Type of packaging	44 mm wide tape
Pieces per package	400
Denomination packing units	Pcs.
[W] tape width	44 mm
[A] coil diameter	330 mm
[W2] coil overall dimension	50.4 mm
Outer packaging type	Transparent-Bag
ESD level	(D) electrostatically conductive
Specification	DIN EN 61340-5-1 (VDE 0300-5-1): 2008-07

General product information

Type of note	Note on application
Note	Pick and place pads may protrude beyond the components. The PCB layout must ensure that collisions are avoided when components are assembled.

Processing notes

Process	Reflow soldering
Specification	Following IPC/JEDEC J-STD-020D.1:2008-03
	Following IEC 60068-2-58:2005-02
Moisture Sensitive Level	MSL 1
Classification temperature T _c	260 °C

PCB terminal block - PTSM 0,5/ 4-2,5-V SMD R44 - 1771114

Technical data

Processing notes

Solder cycles in the reflow	3
-----------------------------	---

Ambient conditions

Ambient temperature (storage/transport)	-40 °C ... 70 °C
Relative humidity (storage/transport)	30 % ... 70 %
Ambient temperature (assembly)	-5 °C ... 100 °C
Ambient temperature (operation)	-40 °C ... 100 °C (Depending on the current carrying capacity/derating curve)

Termination and connection method

Connection test	IEC 60998-2-2:2002-12
Test result	Test passed
Test for conductor damage and slackening	IEC 60998-2-2:2002-12
	Test passed

Pull-out test

Pull-out test	IEC 60998-2-2:2002-12
Conductor cross section / conductor type / tensile force	0.14 mm ² / solid / > 10 N
	0.2 mm ² / flexible / > 10 N
	0.5 mm ² / solid / > 20 N
	0.75 mm ² / flexible / > 30 N

Mechanical tests according to standard

Test specification	IEC 60998-2-2 (in parts)
--------------------	--------------------------

Electrical tests

Rated current	6 A
Conductor cross section	0.5 mm ²
Rated voltage (III/2)	160 V
Rated surge voltage (III/2)	2.5 kV

Air clearances and creepage distances

Clearances and creepage distances	IEC 60664-1:2007-04
Specification	IEC 60664-1:2007-04
Minimum clearance - inhomogeneous field (III/3)	1.5 mm
Minimum clearance - inhomogeneous field (III/2)	1.5 mm
Minimum clearance - inhomogeneous field (II/2)	1.5 mm
Minimum creepage distance value (III/3)	1.3 mm
Minimum creepage distance value (III/2)	1.6 mm
Minimum creepage distance value (II/2)	1.6 mm

Temperature-rise test

PCB terminal block - PTSM 0,5/ 4-2,5-V SMD R44 - 1771114

Technical data

Temperature-rise test

Specification	IEC 60998-2-1:2002-12
Requirement temperature-rise test	Increase in temperature ≤ 45 K

Current carrying capacity / derating curves

Caption	Type: PTSM 0,5/...-2,5-V SMD R44 Tested according to DIN EN 60512-5-2:2003-01 Reduction factor = 1 Number of positions: 5
---------	--

Vibration test

Specification	IEC 60068-2-6:2007-12
Frequency	10 - 150 - 10 Hz
Sweep speed	1 octave/min
Amplitude	0.35 mm (10 - 60.1 Hz)
Acceleration	5g (60.1 - 150 Hz)
Test duration per axis	2.5 h

Insulation resistance

Specification	IEC 60998-1:2002-12
Result	Test passed
Insulation resistance, neighboring positions	> 5 M Ω

Glow-wire test

Specification	IEC 60998-1:2002-12
Temperature	850 °C
Time of exposure	5 s

Mechanical strength/tumbling barrel test

Specification	IEC 60998-1:2002-12
Number of drop cycles	50

Standards and Regulations

Connection in acc. with standard	EN-VDE
	UL

Environmental Product Compliance

China RoHS	Environmentally friendly use period: unlimited = EFUP-e
	No hazardous substances above threshold values

Drawings

PCB terminal block - PTSM 0,5/ 4-2,5-V SMD R44 - 1771114

Drilling diagram

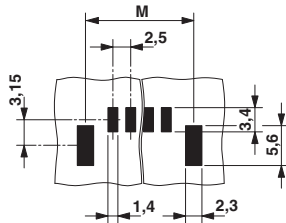

Dimension M: 13.4 mm

Diagram

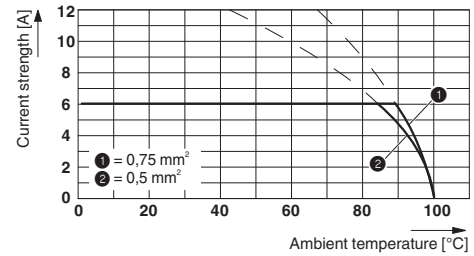

Type: PTSM 0,5/...-2,5-V SMD R44
 Tested according to DIN EN 60512-5-2:2003-01
 Reduction factor = 1
 Number of positions: 5

Dimensional drawing

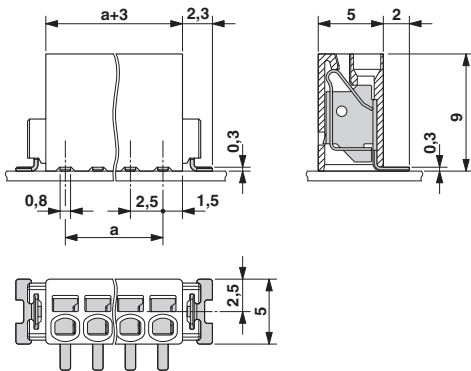

Dimensional drawing

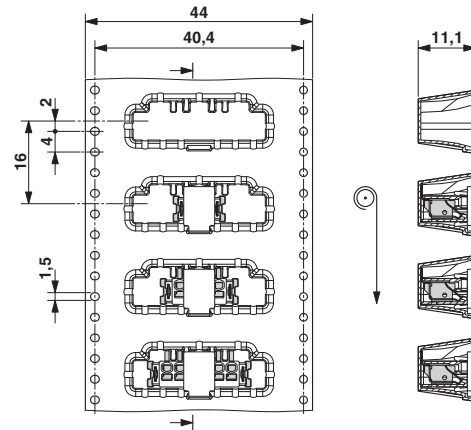

Classifications

eCl@ss

eCl@ss 10.0.1	27440401
eCl@ss 11.0	27460101
eCl@ss 4.0	27141100
eCl@ss 4.1	27141100
eCl@ss 5.0	27141100
eCl@ss 5.1	27261100
eCl@ss 6.0	27261100
eCl@ss 7.0	27440401
eCl@ss 9.0	27440401

PCB terminal block - PTSM 0,5/ 4-2,5-V SMD R44 - 1771114

Classifications

ETIM

ETIM 3.0	EC001121
ETIM 4.0	EC002643
ETIM 6.0	EC002643
ETIM 7.0	EC002643

UNSPSC

UNSPSC 6.01	30211801
UNSPSC 7.0901	39121432
UNSPSC 11	39121432
UNSPSC 12.01	39121432
UNSPSC 13.2	39121432
UNSPSC 18.0	39121432
UNSPSC 19.0	39121432
UNSPSC 20.0	39121432
UNSPSC 21.0	39121432

Approvals

Approvals

Approvals

VDE Zeichengenehmigung / UL Recognized / EAC / cULus Recognized

Ex Approvals

Approval details

VDE Zeichengenehmigung		http://www2.vde.com/de/Institut/Online-Service/VDE-gepruefteProdukte/Seiten/Online-Suche.aspx	40048725
------------------------	---	---	----------

UL Recognized		http://database.ul.com/cgi-bin/XYV/template/LISEXT/1FRAME/index.htm	E118976-20130619
		B	
Nominal voltage UN	150 V		

PCB terminal block - PTSM 0,5/ 4-2,5-V SMD R44 - 1771114

Approvals

	B
Nominal current IN	5 A
mm ² /AWG/kcmil	26-18

EAC		B.01687
-----	---	---------

cULus Recognized		http://database.ul.com/cgi-bin/XYV/template/LISEXT/1FRAME/index.htm	E60425-20030527
------------------	---	---	-----------------

	B
Nominal voltage UN	150 V
Nominal current IN	5 A
mm ² /AWG/kcmil	26-20

Accessories

Accessories

Ferrule

Ferrule - AI 0,25- 6 BU - 3203040



Ferrule, sleeve length: 6 mm, length: 10.5 mm, color: blue

Ferrule - AI 0,25- 6 YE - 3203024



Ferrule, sleeve length: 6 mm, length: 10.5 mm, color: yellow

PCB terminal block - PTSM 0,5/ 4-2,5-V SMD R44 - 1771114

Accessories

Ferrule - AI 0,34- 6 TQ - 3203053



Ferrule, sleeve length: 6 mm, length: 10.5 mm, color: turquoise

Screwdriver tools

Screwdriver - SZS 0,4X2,0 - 1205202



Micro screwdriver, bladed, size: 0.4 x 2.0 x 60 mm, 2-component grip, with non-slip grip and twist cap

Additional products

Sample set - SAMPLE PTSM 0,5/ 4-2,5-V-SMD - 1701086



PCB terminal block, nominal current: 6 A, rated voltage (III/2): 160 V, nominal cross section: 0.5 mm², number of potentials: 4, Number of rows: 1, Number of positions per row: 4, product range: PTSM 0,5/..-V-SMD, pitch: 2.5 mm, connection method: Push-in spring connection, mounting: SMD soldering, conductor/PCB connection direction: 90 °, color: black, Pin layout: Linear pad geometry, Solder pin [P]: 2 mm, type of packaging: packed in cardboard. SAMPLE set with 5 items in belt section. When used as part of soldering process, please use items without SAMPLE marking