

Bridge Rectifier

DF005S1-DF10S1

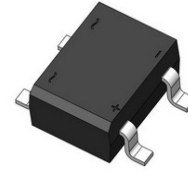

PDIP4 GW
CASE 709AE

Description

With the ever–pressing need to improve power supply efficiency, improve surge rating, improve reliability, and reduce size, the DFxS1 family sets a new standard in performance and cost saving.

The DFxS1 family balances performance against cost. The design offers a moderate surge rating of 35 A required to handle inrush surge and maintain good reliability, with fair price.

The DFxS1 achieves good performance in a SDIP surface mount form factor, reducing board space and volumetric requirements vs. competitive devices.

Features

- Maximum Surge Rating:
 - ◆ $I_{FSM} = 35\text{ A}$
 - ◆ $I^2t = 5.1\text{ A}^2\text{Sec}$
- Optimized V_F : Typical 0.95 V at 1 A, 25°C
- DF10S Socket Compatible
- Glass Passivated Junctions
- Lead Free Compliant to EU RoHS 2002/95/EU Directives
- Green Molding Compound: IEC61249
- Qualified with IR Reflow and Wave Soldering

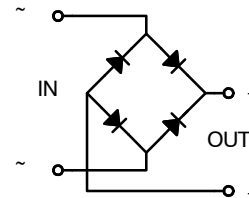

MARKING DIAGRAM

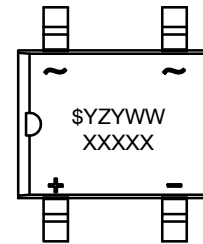

- \$Y = onsemi Logo
- Z = Assembly Plant Code
- YWW = Date Code (Year and Week)
- XXXXX = Specific Device Code

ORDERING INFORMATION

See detailed ordering and shipping information on page 4 of this data sheet.

DF005S1–DF10S1

ABSOLUTE MAXIMUM RATINGS (Values are at $T_A = 25^\circ\text{C}$ unless otherwise noted.)

| Symbol | Parameter | Value | | | | | | | Unit |
|-------------|--|-------------|--------|--------|--------|--------|--------|--------|------------------|
| | | DF005S1 | DF01S1 | DF02S1 | DF04S1 | DF06S1 | DF08S1 | DF10S1 | |
| V_{RRM} | Maximum Recurrent Peak Reverse Voltage | 50 | 100 | 200 | 400 | 600 | 800 | 1000 | V |
| V_{RMS} | Maximum RMS Bridge Input Voltage | 35 | 70 | 140 | 280 | 420 | 560 | 700 | V |
| V_{DC} | Maximum DC Blocking Voltage | 50 | 100 | 200 | 400 | 600 | 800 | 1000 | V |
| $I_{F(AV)}$ | Maximum Average Forward Current $T_A = 40^\circ\text{C}$ | 1.0 | | | | | | | A |
| I_{FSM} | Peak Forward Surge Current 8.3 ms Single Half-Sine Wave Superimposed on Rated Load (JEDEC Method) | 35 | | | | | | | A |
| T_{STG} | Storage Temperature Range | -55 to +150 | | | | | | | $^\circ\text{C}$ |
| T_J | Operating Junction Temperature Range | -55 to +150 | | | | | | | $^\circ\text{C}$ |

Stresses exceeding those listed in the Maximum Ratings table may damage the device. If any of these limits are exceeded, device functionality should not be assumed, damage may occur and reliability may be affected.

THERMAL CHARACTERISTICS (Note 1)

| Symbol | Parameter | Conditions | Max. | Unit |
|-----------------|---|---|------|---------------------------|
| $R_{\theta JA}$ | Thermal Resistance, Junction to Ambient | Single-Die Measurement (Maximum Land Pattern: 13 × 13 mm) | 65 | $^\circ\text{C}/\text{W}$ |
| | | Multi-Die Measurement (Maximum Land Pattern: 13 × 13 mm) | 50 | |
| | | Multi-Die Measurement (Minimum Land Pattern: 1.3 × 1.5 mm) | 105 | |
| Ψ_{JL} | Thermal Characterization Parameter, Junction to Lead | Single-Die Measurement (Maximum and Minimum Land Pattern) | 27 | $^\circ\text{C}/\text{W}$ |

1. The thermal resistances ($R_{\theta JA}$ & Ψ_{JL}) are characterized with the device mounted on the following FR4 printed circuit boards, as shown in Figure 1 and Figure 2. PCB size: 76.2 × 114.3 mm.
Heating effect from adjacent dice is considered and only two dice are powered at the same time.

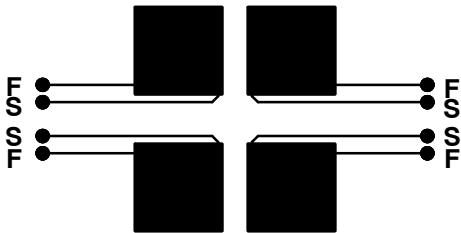

Figure 1. Maximum Pads of 2 oz Copper



Figure 2. Minimum Pads of 2 oz Copper

ELECTRICAL CHARACTERISTICS (Values are at $T_A = 25^\circ\text{C}$ unless otherwise noted.)

| Symbol | Parameter | Conditions | Min | Typ | Max | Unit |
|--------|--|--|-----|-----|-----|----------------------|
| V_F | Forward Voltage Drop per Bridge Element | $I_F = 1.0 \text{ A}$ | | | 1.1 | V |
| I_R | DC Reverse Current at Rated DC Blocking Voltage | $T_J = 25^\circ\text{C}$ | | | 3 | μA |
| | | $T_J = 125^\circ\text{C}$ | | | 500 | |
| I^2t | Rating for Fusing ($t < 8.3 \text{ ms}$) | | | | 5.1 | A^2S |
| C_J | Junction Capacitance | $V_R = 4.0 \text{ V}, f = 1.0 \text{ MHz}$ | | 10 | | pF |

Product parametric performance is indicated in the Electrical Characteristics for the listed test conditions, unless otherwise noted. Product performance may not be indicated by the Electrical Characteristics if operated under different conditions.

TYPICAL PERFORMANCE CHARACTERISTICS

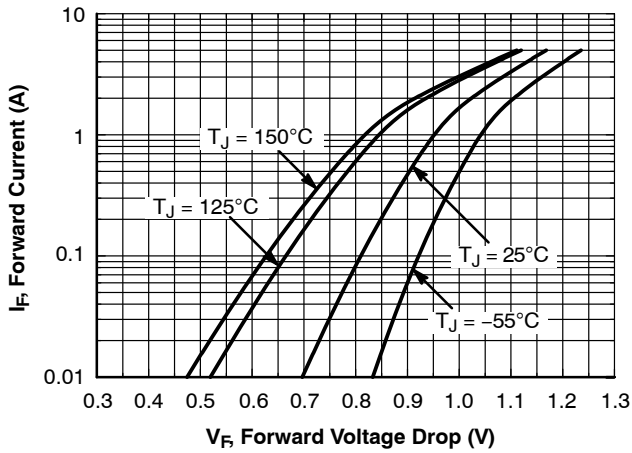

Figure 3. Typical Instantaneous Forward Characteristics

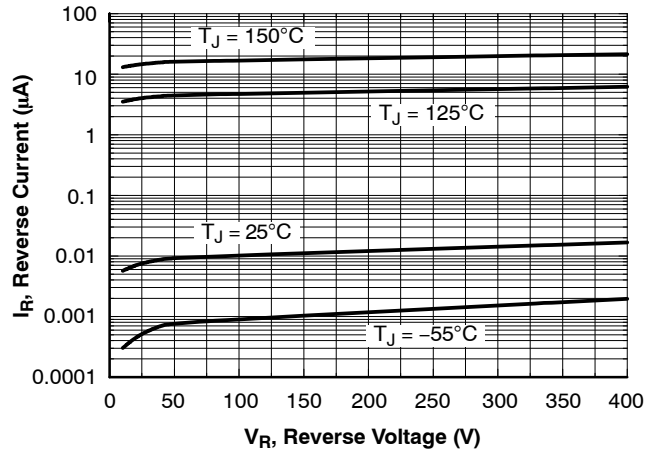

Figure 4. Typical Reverse Characteristics

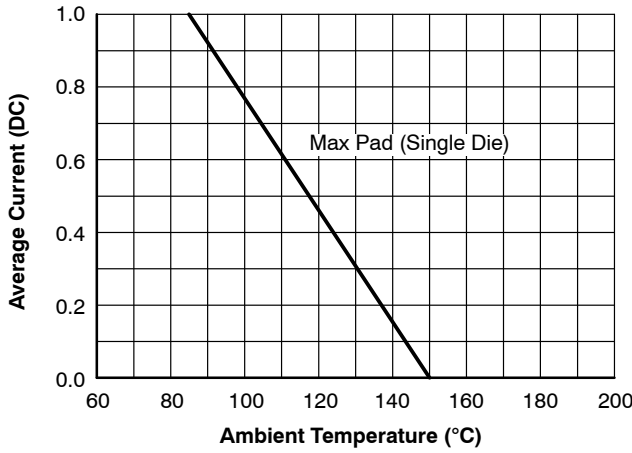

Figure 5. Maximum Average Current vs. Ambient Temperature

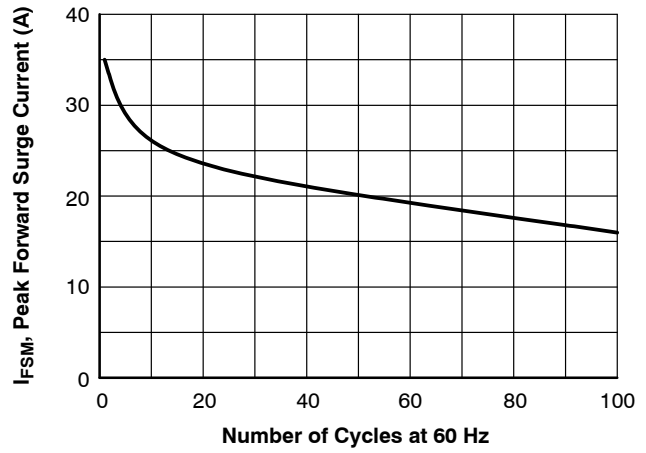

Figure 6. Peak Forward Surge Current vs. Number of Cycles at 60 Hz

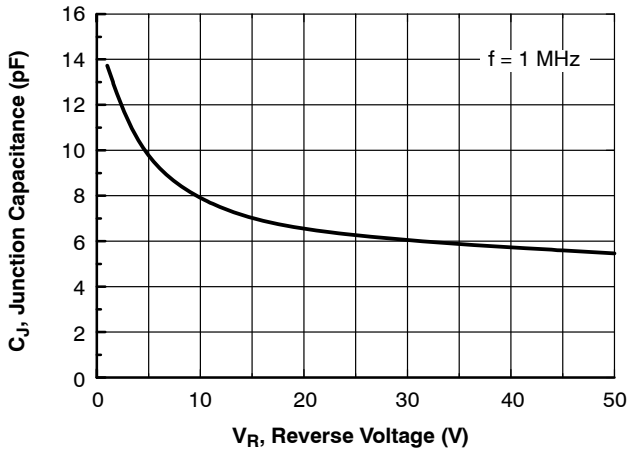

Figure 7. Typical Junction Capacitance

DF005S1-DF10S1

ORDERING INFORMATION

| Part Number | Top Mark | Package | Shipping [†] |
|-------------|----------|------------------------------------|-----------------------|
| DF005S1 | DF005S1 | PDIP4 GW (Pb-Free, Halide Free) | 1500 / Tape & Reel |
| DF01S1 | DF01S1 | | |
| DF02S1 | DF02S1 | | |
| DF04S1 | DF04S1 | | |
| DF06S1 | DF06S1 | | |
| DF08S1 | DF08S1 | | |
| DF10S1 | DF10S1 | | |

[†]For information on tape and reel specifications, including part orientation and tape sizes, please refer to our Tape and Reel Packaging Specifications Brochure, [BRD8011/D](#).

MECHANICAL CASE OUTLINE
PACKAGE DIMENSIONS



PDIP4 GW
CASE 709AE
ISSUE O

DATE 31 JUL 2016

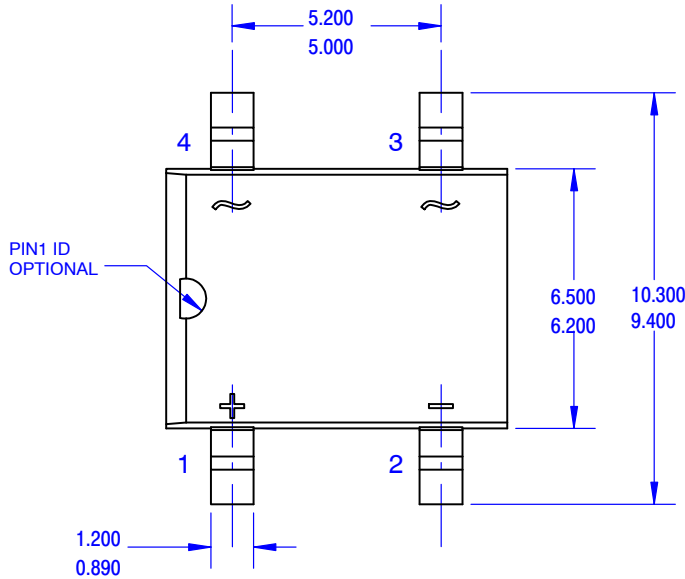

TOP VIEW

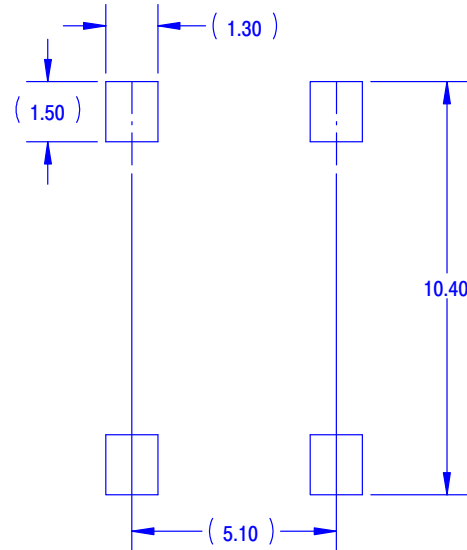

LAND PATTERN RECOMMENDATION

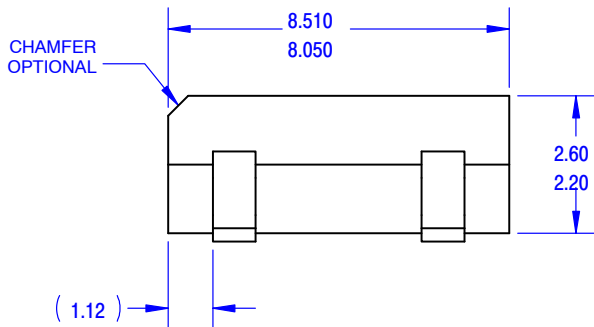

SIDE VIEW

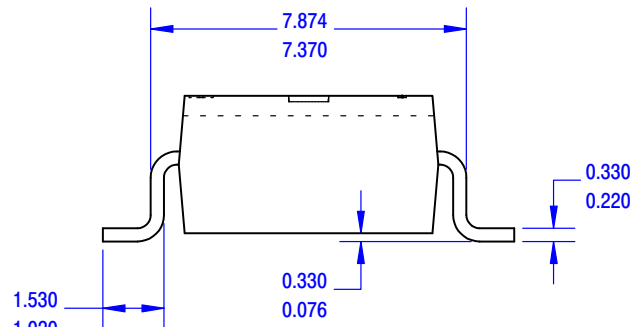

END VIEW

NOTES:

- A. THIS PACKAGE DOES NOT CONFORM TO ANY REFERENCE STANDARD.
- B. ALL DIMENSIONS ARE IN MILLIMETERS.
- C. DIMENSIONS ARE EXCLUSIVE OF BURRS, MOLD FLASH AND TIE BAR PROTRUSIONS.

| | | |
|-------------------------|--------------------|--|
| DOCUMENT NUMBER: | 98AON13473G | Electronic versions are uncontrolled except when accessed directly from the Document Repository. Printed versions are uncontrolled except when stamped "CONTROLLED COPY" in red. |
| DESCRIPTION: | PDIP4 GW | PAGE 1 OF 1 |

onsemi and ONSEMI are trademarks of Semiconductor Components Industries, LLC dba onsemi or its subsidiaries in the United States and/or other countries. onsemi reserves the right to make changes without further notice to any products herein. onsemi makes no warranty, representation or guarantee regarding the suitability of its products for any particular purpose, nor does onsemi assume any liability arising out of the application or use of any product or circuit, and specifically disclaims any and all liability, including without limitation special, consequential or incidental damages. onsemi does not convey any license under its patent rights nor the rights of others.

onsemi, **Onsemi**, and other names, marks, and brands are registered and/or common law trademarks of Semiconductor Components Industries, LLC dba "**onsemi**" or its affiliates and/or subsidiaries in the United States and/or other countries. **onsemi** owns the rights to a number of patents, trademarks, copyrights, trade secrets, and other intellectual property. A listing of **onsemi**'s product/patent coverage may be accessed at www.onsemi.com/site/pdf/Patent-Marking.pdf. **onsemi** reserves the right to make changes at any time to any products or information herein, without notice. The information herein is provided "as-is" and **onsemi** makes no warranty, representation or guarantee regarding the accuracy of the information, product features, availability, functionality, or suitability of its products for any particular purpose, nor does **onsemi** assume any liability arising out of the application or use of any product or circuit, and specifically disclaims any and all liability, including without limitation special, consequential or incidental damages. Buyer is responsible for its products and applications using **onsemi** products, including compliance with all laws, regulations and safety requirements or standards, regardless of any support or applications information provided by **onsemi**. "Typical" parameters which may be provided in **onsemi** data sheets and/or specifications can and do vary in different applications and actual performance may vary over time. All operating parameters, including "Typicals" must be validated for each customer application by customer's technical experts. **onsemi** does not convey any license under any of its intellectual property rights nor the rights of others. **onsemi** products are not designed, intended, or authorized for use as a critical component in life support systems or any FDA Class 3 medical devices or medical devices with a same or similar classification in a foreign jurisdiction or any devices intended for implantation in the human body. Should Buyer purchase or use **onsemi** products for any such unintended or unauthorized application, Buyer shall indemnify and hold **onsemi** and its officers, employees, subsidiaries, affiliates, and distributors harmless against all claims, costs, damages, and expenses, and reasonable attorney fees arising out of, directly or indirectly, any claim of personal injury or death associated with such unintended or unauthorized use, even if such claim alleges that **onsemi** was negligent regarding the design or manufacture of the part. **onsemi** is an Equal Opportunity/Affirmative Action Employer. This literature is subject to all applicable copyright laws and is not for resale in any manner.

ADDITIONAL INFORMATION

TECHNICAL PUBLICATIONS:

Technical Library: www.onsemi.com/design/resources/technical-documentation
onsemi Website: www.onsemi.com

ONLINE SUPPORT: www.onsemi.com/support

For additional information, please contact your local Sales Representative at www.onsemi.com/support/sales

