

CURRENT MODE PWM CONTROLLER

DESCRIPTION

The UC3842/UC3843/UC3844/UC3845 are fixed frequency current mode PWM controller. They are specially designed for OFF-Line and DC to DC converter applications with a minimal external components. Internally implemented circuits include a trimmed oscillator for precise duty cycle control, a temperature compensated reference, high gain error amplifier, current sensing comparator, and a high current totem pole output ideally suited for driving a power MOSFET. Protection circuitry includes built under voltage lockout and current limiting.

The UC3842, UC3844 have UVLO thresholds of 16 V (on) and 10 V (off). The corresponding thresholds for the UC3843, UC3845 are 8.4V (on) and 7.6V (off). The UC3842, UC3843 can operate within 100% duty cycle. The UC3844, UC3845 can operate within 50% duty cycle.

PIN CONNECTION (TOP VIEW)

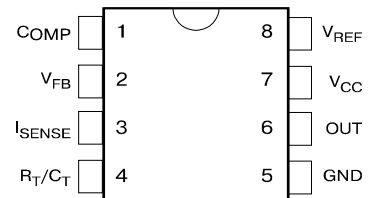

FEATURES

- Low Start-Up and Operating Current
- High Current Totem Pole Output
- Under voltage Lockout With Hysteresis
- Operating Frequency Up To 500KHz

BLOCK DIAGRAM

(toggle flip flop used only in UC3844, UC3845)

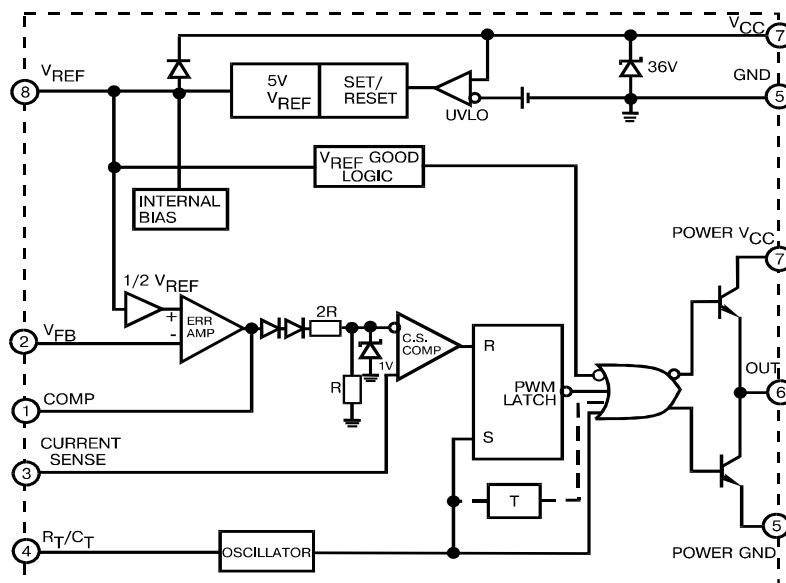

Absolute Maximum Ratings

Characteristic	Symbol	Value	Unit
Supply Voltage (low impedance source)	V_{CC}	30	V
Output Current	I_o	± 1	A
Input Voltage (Analog Inputs pins 2,3)	V_i	-0.3 to 5.5	V
Error Amp Output Sink Current	$I_{SINK(E.A)}$	10	mA
Power Dissipation ($T_A=25^\circ\text{C}$)	P_o	1	W
Storage Temperature Range	T_{stg}	-65 to 150	$^\circ\text{C}$
Lead Temperature (soldering 5 sec.)	T_L	260	$^\circ\text{C}$

Electrical characteristics (* $V_{CC}=15V$, $R_T=10k\Omega$, $C_T=3.3nF$, $T_A=0^\circ C$ to $+70^\circ C$, unless otherwise specified)

Characteristics	Symbol	Test Condition	Min	Typ	Max	Unit
Reference Section						
Reference Output Voltage	V_{REF}	$T_J = 25^\circ C$, $I_{REF} = 1\text{ mA}$	4.9	5.0	5.1	V
Line Regulation	ΔV_{REF}	$12V \leq V_{CC} \leq 25\text{ V}$		6.0	20	mV
Load Regulation	ΔV_{REF}	$1\text{ mA} \leq I_{REF} \leq 20\text{ mA}$		6.0	25	
Short Circuit Output Current	I_{SC}	$T_A = 25^\circ C$		-100	-180	mA
Oscillator Section						
Oscillation Frequency	f	$T_J = 25^\circ C$	47	52	57	KHz
Frequency Change with Voltage	$\Delta f/\Delta V_{CC}$	$12V \leq V_{CC} \leq 25\text{ V}$		0.05	1.0	%
Oscillator Amplitude	$V_{(OSC)}$	(peak to peak)		1.6		V
Error Amplifier Section						
Input Bias Current	I_{BIAS}	$V_{FB}=3V$		-0.1	-2	μA
Input Voltage	$V_{I(E.A)}$	$V_{pin1} = 2.5V$	2.42	2.5	2.58	V
Open Loop Voltage Gain	A_{VOL}	$2V \leq V_0 \leq 4V$	65	90		dB
Unity Gain Bandwidth	UGBW	$T_J=25^\circ C$, Note 3	0.5	0.6		MHz
Power Supply Rejection Ratio	PSRR	$12V \leq V_{CC} \leq 25\text{ V}$	60	70		dB
Output Sink Current	I_{SINK}	$V_{pin2} = 2.7V$, $V_{pin1} = 1.1V$	2	7		mA
Output Source Current	I_{SOURCE}	$V_{pin2} = 2.3V$, $V_{pin1} = 5V$	-0.5	-1.0		mA
High Output Voltage	V_{OH}	$V_{pin2} = 2.3V$, $R_L = 15K\Omega$ to GND	5.0	6.0		V
Low Output Voltage	V_{OL}	$V_{pin2} = 2.7V$, $R_L = 15K\Omega$ to PIN 8		0.8	1.1	
Current Sense Section						
Gain	G_V	(Note 1 & 2)	2.85	3.0	3.15	V/V
Maximum Input Signal	$V_{I(MAX)}$	$V_{pin1} = 5V$ (Note1)	0.9	1.0	1.1	V
Supply Voltage Rejection	SVR	$12V \leq V_{CC} \leq 25\text{ V}$ (Note 1)		70		dB
Input Bias Current	I_{BIAS}	$V_{pin3} = 3V$		-3.0	-10	μA
Output Section						
Low Output Voltage	V_{OL}	$I_{SINK} = 20\text{ mA}$		0.08	0.4	V
		$I_{SINK} = 200\text{ mA}$		1.4	2.2	
High Output Voltage	V_{OH}	$I_{SINK} = 20\text{ mA}$	13	13.5		
		$I_{SINK} = 200\text{ mA}$	12	13.0		
Rise Time	t_R	$T_J = 25^\circ C$, $C_L = 1\text{ nF}$ (Note 3)		45	150	nS
Fall Time	t_F	$T_J = 25^\circ C$, $C_L = 1\text{ nF}$ (Note 3)		35	150	
Undervoltage Lockout Section						
Start Threshold	$V_{TH(ST)}$	UC3842,UC3844	14.5	16.0	17.5	V
		UC3843,UC3845	7.8	8.4	9.0	
Min. Operating Voltage (After Turn On)	$V_{OPR(min)}$	UC3842,UC3844	8.5	10	11.5	V
		UC3843,UC3845	7.0	7.6	8.2	
PWM Section						
Max. Duty Cycle	$D_{(MAX)}$	UC3842,UC3843	95	97	100	%
		UC3844,UC3845	47	48	50	
Min. Duty Cycle	$D_{(MAX)}$			0		
Total Standby Current						
Start-Up Current	I_{ST}	UC3842/43/44/45		0.17	0.3	mA
Operating Supply Current	$I_{CC(OPR)}$	$V_{pin3} = V_{pin2} = 0V$		13	17	
Zener Voltage	V_Z	$I_{CC}=25\text{ mA}$	30	38		V

* Adjust V_{CC} above the start threshold before setting it to 15V.

Note 1: Parameter measured at trip point of latch with $V_{pin2}=0$.

Note 2: Gain defined as $A=\Delta V_{pin1}/\Delta V_{pin3}$; $0 \leq V_{pin3} \leq 0.8V$.

Note 3: These parameters, although guaranteed, are not 100% tested in production.

PIN FUNCTION

N	FUNCTION	DESCRIPTION
1	COMP	This pin is the Error Amplifier output and is made for loop compensation.
2	V_{FB}	This is the inverting input of the Error Amplifier. It is normally connected to the switching power supply output through a resistor divider.
3	I_{SENSE}	A voltage proportional to inductor current is connected to this input. The PWM uses this information to terminate the output switch conduction.
4	R_T/C_T	The oscillator frequency and maximum Output duty cycle are programmed by connecting resistor R_T to V_{ref} and capacitor C_T to ground.
5	GROUND	This pin is the combined control circuitry and power ground.
6	OUTPUT	This output directly drives the gate of a power MOSFET. Peak currents up to 1A are sourced and sink by this pin.
7	V_{CC}	This pin is the positive supply of the integrated circuit.
8	V_{ref}	This is the reference output. It provides charging current for capacitor C_T through resistor R_T .

APPLICATION INFORMATION

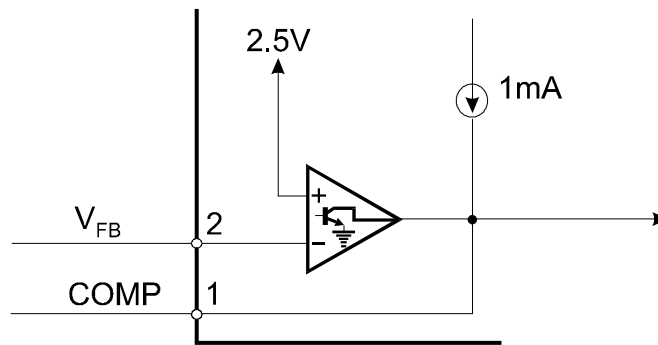
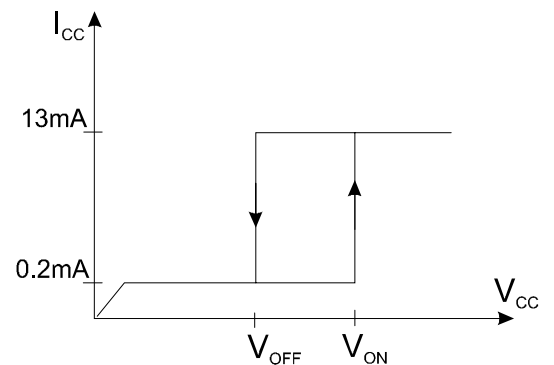
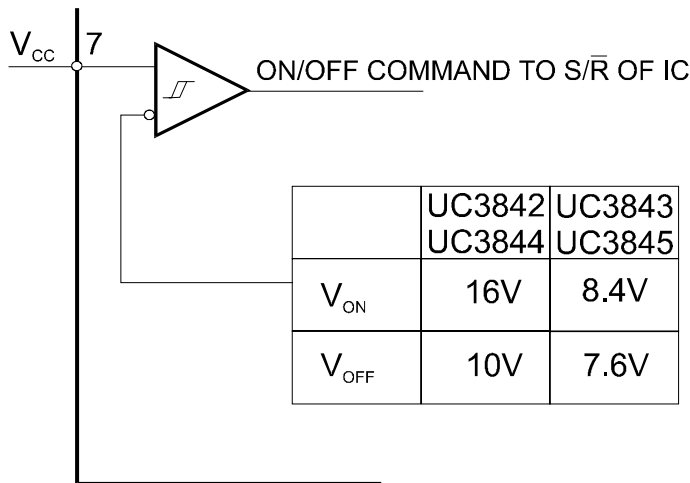
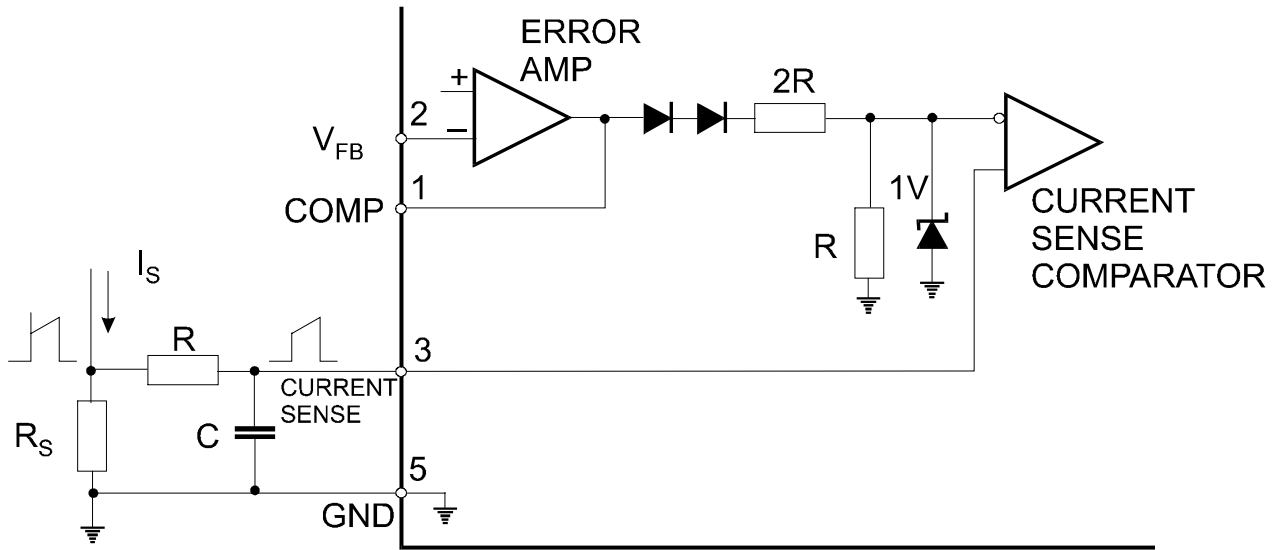

Figure 1. Error Amp Configuration



During UVLO, the Output is low

Figure 2. Under voltage Lockout



Peak current is determined by $I_{S \max} \approx \frac{1.0V}{R_S}$

Figure 3. Current Sense Circuit

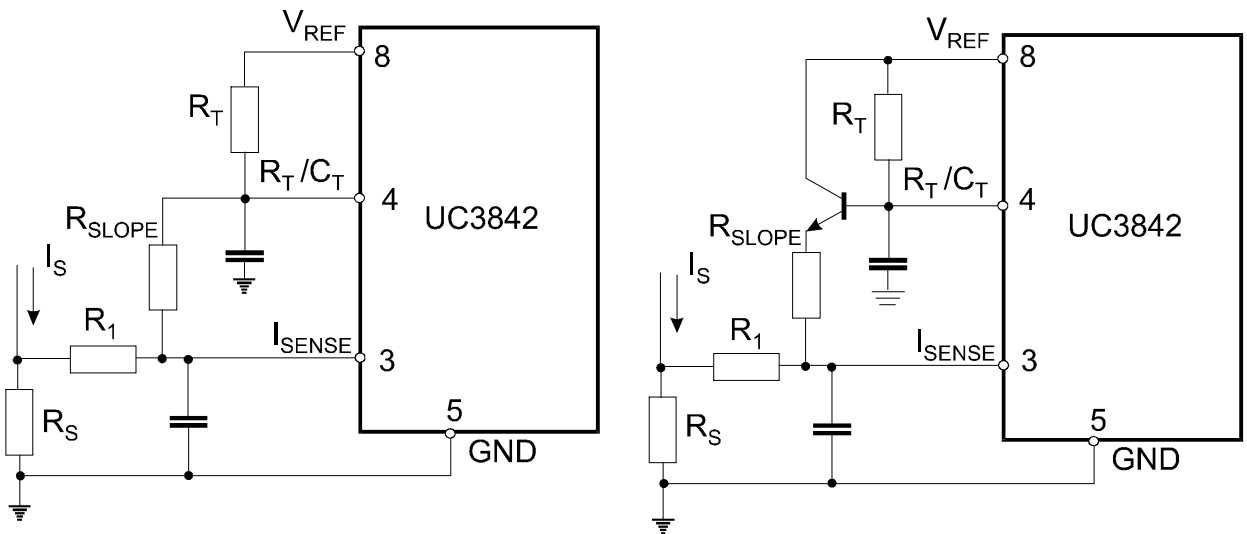
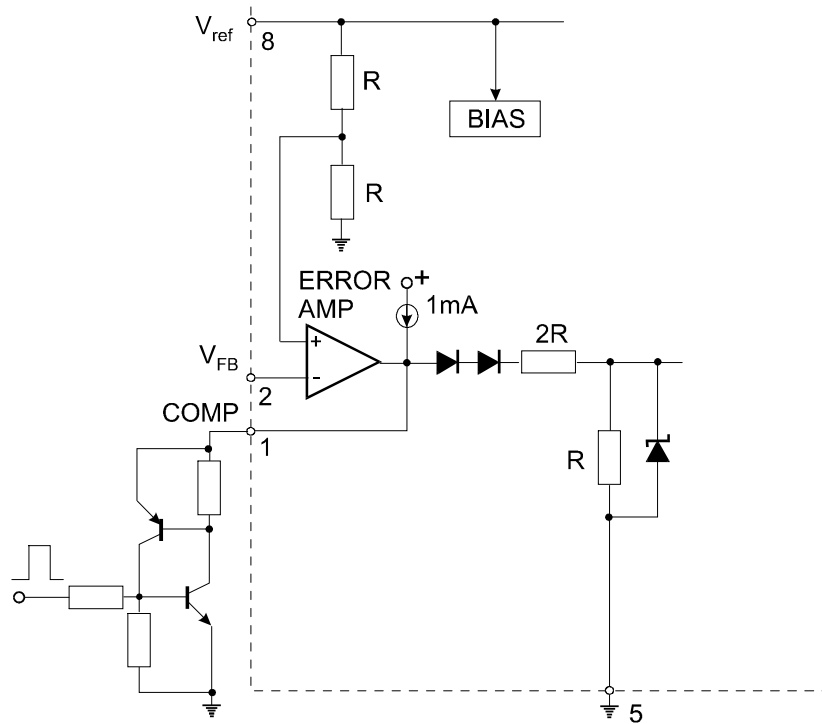
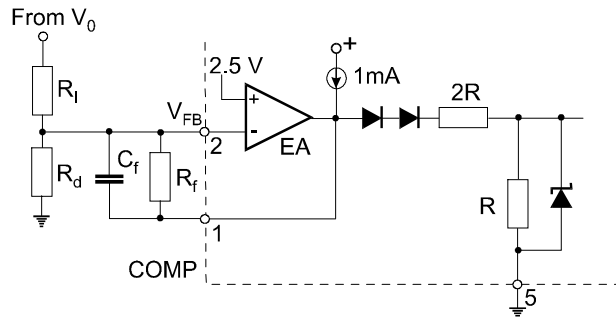

Figure 4. Slope Compensation Techniques



SCR must be selected for a holding current of less than 0.5mA.
The simple two transistor circuit can be used in place of the SCR as shown.

Figure 5. Latched Shutdown



Error Amp compensation circuit for stabilizing any current-mode topology except for boost and flyback converters operating with continuous inductor current.

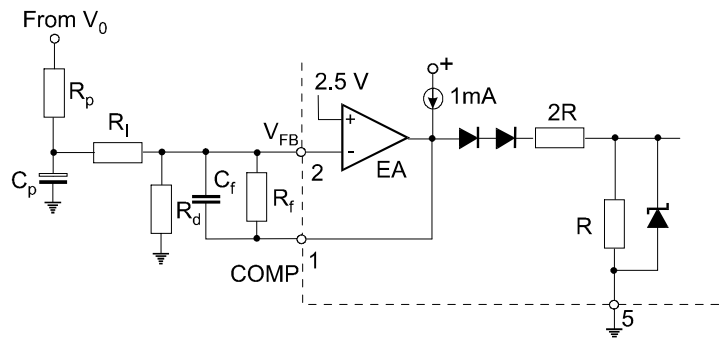

Error Amp compensation circuit for stabilizing current-mode boost and flyback topologies operating with continuous inductor current.

Figure 6. Error Amplifier Compensation

TYPICAL PERFORMANCE CHARACTERISTICS

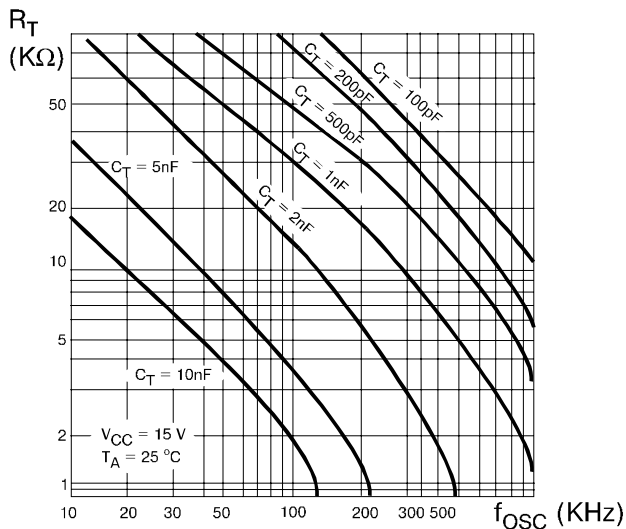

Figure 1. Timing Resistor vs. Oscillator Frequency

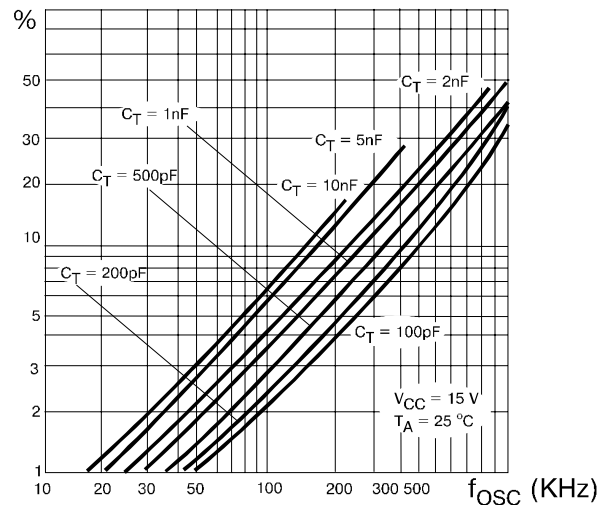

Figure 2. Output Dead-Time vs. Oscillator Frequency

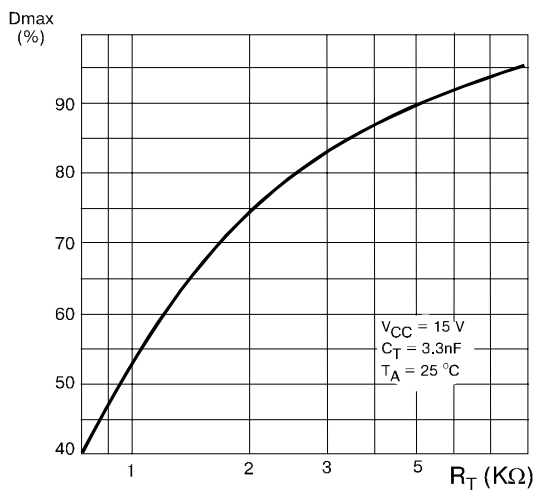

Figure 3. Maximum Output Duty Cycle vs. Timing Resistor (UC3842/43)

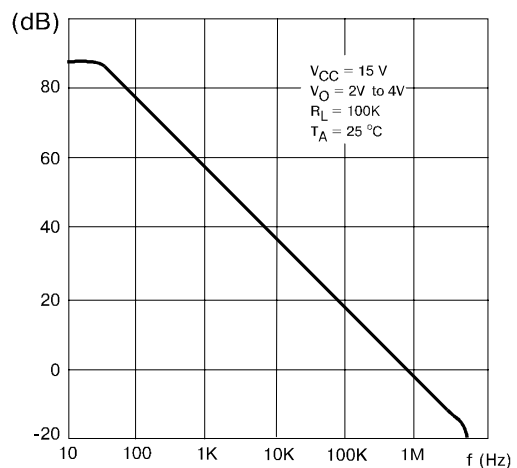

Figure 4. Error Amp Open-Loop Gain vs. Frequency

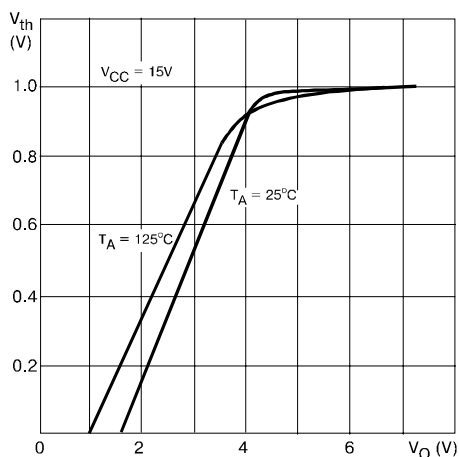

Figure 5. Current Sense Input Threshold vs. Error Amp Output Voltage

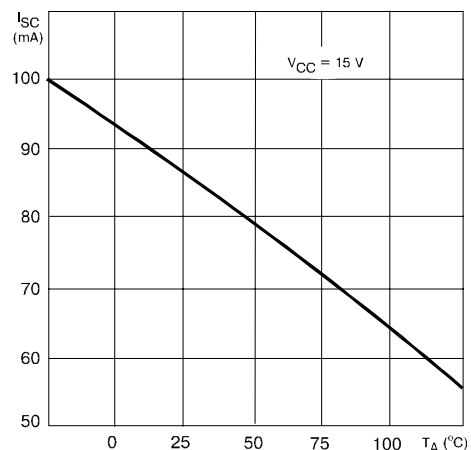

Figure 6. Reference Short Circuit Current vs. Temperature

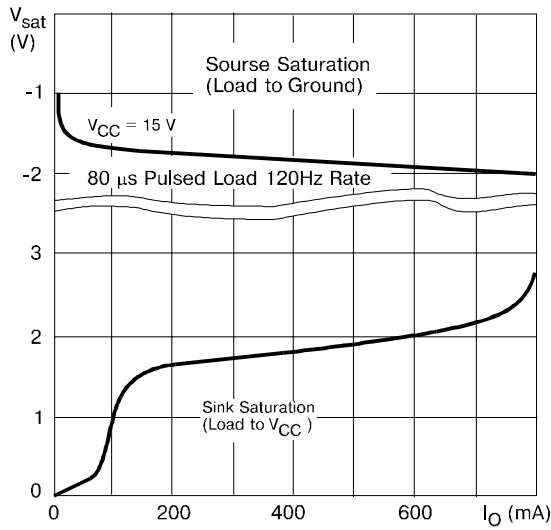

Figure 7. Output Saturation Voltage vs. Load Current
 $T_A = 25^\circ\text{C}$

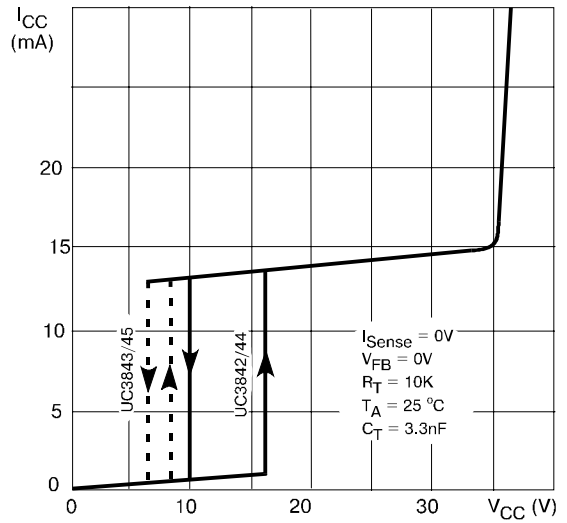

Figure 8. Supply Current vs. Supply Voltage

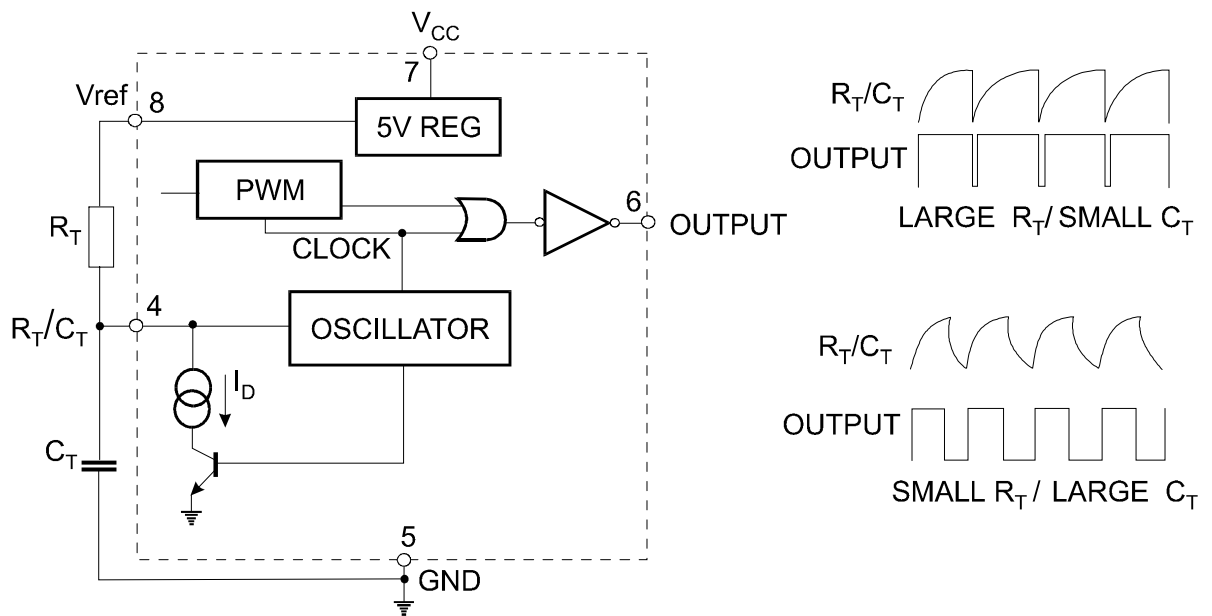

Figure 9. Oscillator and Output Waveforms

Important statement:

Huaguan Semiconductor Co,Ltd. reserves the right to change the products and services provided without notice. Customers should obtain the latest relevant information before ordering, and verify the timeliness and accuracy of this information.

Customers are responsible for complying with safety standards and taking safety measures when using our products for system design and machine manufacturing to avoid potential risks that may result in personal injury or property damage.

Our products are not licensed for applications in life support, military, aerospace, etc., so we do not bear the consequences of the application of these products in these fields.

Our documentation is only permitted to be copied without any tampering with the content, so we do not accept any responsibility or liability for the altered documents.