

WLMDU9456001JT / 172946001**MagI³C Power Module**
LDHM - LED Step Down High Current Module

4.5 - 60V / 300 - 450mA / Up to 16 high power 3.2V LEDs

DESCRIPTION

The LDHM of the MagI³C Power Module family provides a fully integrated constant-current LED driver, including the controller IC, freewheeling diode and inductor in one package.

The 172946001 offers high efficiency and delivers an LED current in the range of 300mA to 450mA. It operates with an input voltage from 4.5V up to 60V and supports up to 16 LEDs in series, each with a forward voltage of 3.2V. The MagI³C Power Module is designed to maintain chromaticity during PWM dimming.

It is available in an innovative and robust industrial high power density TO263-7EP (10.16 x 13.77 x 4.57mm) package that enhances thermal performance.

The LDHM module has on-board over temperature protection, input undervoltage lockout and LED short-circuit protection.

TYPICAL APPLICATIONS

Illumination lighting for industry, railway, street lights, ambient, architecture, stage, construction site, signage, traffic lights, horticulture, display background applications.

FEATURES

- Peak efficiency up to 95%
- Default LED current: 350mA
- Adjustable LED current from 300 to 450mA
- Current sharing in parallel operation for higher output demands
- Wide input voltage range from 4.5V to 60V
- Up to 16 high power 3.2V LEDs
- Maximum output power: 23W
- PWM dimming / analog dimming
- Integrated shielded inductor
- Single exposed pad for best-in-class thermal performance
- Typical LED current accuracy: $\pm 3.5\%$
- LED short circuit protection
- Overtemperature protection
- Undervoltage lockout (UVLO)
- Fixed switching frequency at 800kHz
- Compatible with ceramic and low ESR capacitors
- Operating ambient temp. range up to 85°C
- Operating junction temp. range: -40 to 125°C
- RoHS & REACh compliant
- Mold compound UL 94 Class V0 (flammability testing) certified
- Complies with EN 55015 radiated emissions standard

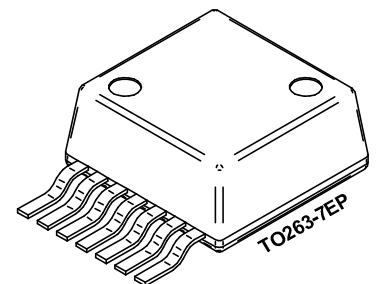
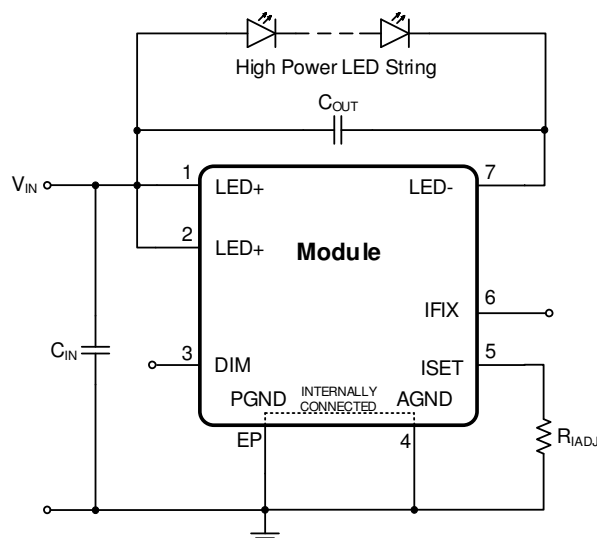
TYPICAL CIRCUIT DIAGRAM

WLMDU9456001JT / 172946001

MagI³C Power Module
LDHM - LED Step Down High Current Module



PACKAGE

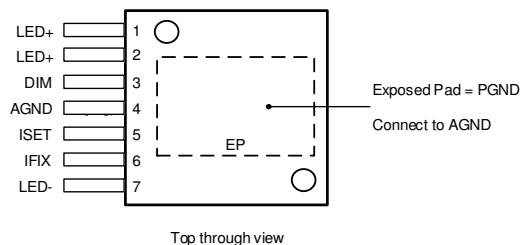

MARKING DESCRIPTION

Marking	Description
WE	Würth Elektronik trade name
Y	Year
M	Month
LLLL	Lot trace code
G3	Lead finish code per JEDEC norm (green 3 mat sin)
WE201	Part identifier

PIN DESCRIPTION

SYMBOL	PIN No.	TYPE	PIN DESCRIPTION
LED+	1, 2	Power	Supply pin and rail connection to the anode of the LED string.
DIM	3	Input	Dimming control pin. If left floating, the driver is enabled. Optional: apply a logic level PWM signal to control the brightness of the LED string using PWM dimming.
AGND	4	Supply	The analog ground pin is the low noise GND for the current setting resistor and the internal reference. Do not connect the input capacitor to this pin. The analog ground pin is internally connected to the exposed pad.
ISET	5	Input	Connect a resistor between the ISET pin and AGND to adjust the LED current in a range of 300mA to 450mA. If the default LED current of 350mA is desired, leave this pin floating and connect IFIX to AGND.
IFIX	6	Input	Connect the IFIX pin to AGND to set the LED current to the default value of 350mA. In case a different value of LED current is required, leave this pin floating.
LED-	7	Power	The current return pin of the LED string. Connect to the cathode of the LED string.
PGND	EP	Power	Exposed power ground pad. Connect to copper plane(s) with thermal vias for better thermal performance. This pin is internally connected to AGND.

WLMDU9456001JT / 172946001

MagI³C Power Module
LDHM - LED Step Down High Current Module

**ORDERING INFORMATION**

ORDER CODE	SPECIFICATIONS	PACKAGE	PACKING UNIT
172946001	4.5 - 60V / 300 - 450mA / Up to 16 high power 3.2V LEDs	TO263-7EP	13" Reel (250 pieces)
178946001	4.5 - 60V / 300 - 450mA / Up to 16 high power 3.2V LEDs	Eval Board	

SALES INFORMATION

SALES CONTACT
<p>Würth Elektronik eiSos GmbH & Co. KG EMC & Inductive Solutions Max-Eyth-Str. 1 74638 Waldenburg Germany Tel. +49 (0) 79 42 945 0 www.we-online.com/powermodules Technical support: powermodules@we-online.com</p>

WLMDU9456001JT / 172946001**MagI³C** Power Module
LDHM - LED Step Down High Current Module**ABSOLUTE MAXIMUM RATINGS**

Caution:

Exceeding the listed absolute maximum ratings may affect the device negatively and may cause permanent damage.

SYMBOL	PARAMETER	LIMITS		UNIT
		MIN	MAX	
LED+, LED-	LED supply pins	-0.3	67	V
DIM	PWM dimming input pin	-0.3	6	V
IFIX, ISET	LED current adjustment pins	-0.3	5	V
V _{ESD-HBM}	ESD, human body model ⁽¹⁾ (All pins except IFIX pin)	-2	2	kV
T _J	Junction temperature	-	150	°C
T _{storage}	Assembled, non operating storage temperature	-65	150	°C
T _{SOLR}	Peak temperature during reflow soldering, max. 30sec ⁽²⁾ Maximum two cycles!	-	245	°C

OPERATING CONDITIONSOperating conditions are conditions under which the operation of the device is intended to be functional. All values are referenced to GND. MIN and MAX limits are valid for the recommended ambient temperature range of **-40°C to 85°C**.

SYMBOL	PARAMETER	MIN ⁽³⁾	TYP ⁽⁴⁾	MAX ⁽³⁾	UNIT
LED+	Input voltage	4.5	-	60	V
DIM	PWM dimming input	0	-	5.5	V
T _A	Ambient temperature range	-40	-	85	°C
T _J	Junction temperature range	-40	-	125	°C
I _{LED}	Nominal LED current	300		450	mA

THERMAL SPECIFICATIONS

SYMBOL	PARAMETER	TYP	UNIT
θ _{JA}	Junction-to-ambient thermal resistance, ⁽⁵⁾	19.3	°C/W
θ _{JC}	Junction-to-case thermal resistance, no air flow	1.9	°C/W
T _{SD}	Thermal shut down, junction temperature, rising	170	°C
T _{SD-HYST}	Thermal shut down hysteresis, falling	10	°C

WLMDU9456001JT / 172946001

MagI³C Power Module
LDHM - LED Step Down High Current Module

ELECTRICAL SPECIFICATIONS

MIN and MAX limits are valid for the recommended junction temperature range of **-40°C to 125°C** unless otherwise stated. Typical values represent statistically the utmost probability at following conditions: $V_{IN}=48V$, $I_{LED} = 350$ mA.

SYMBOL	PARAMETER	TEST CONDITIONS	MIN ⁽³⁾	TYP ⁽⁴⁾	MAX ⁽³⁾	UNIT
I_{IN}	Input current	$V_{IN} = 4.5$ to $60V$ $V_{LED} = 0V$ $V_{DIM} = 0V$ ($I_{LED} = 0A$) $T_J = 25^\circ C$	2.1	2.65	3.0	mA
I_{LED}	LED current	$V_{LED} = 24V$ IFIX connected to GND $R_{IADJ} = \text{open}$ $T_J = -40^\circ C$ to $125^\circ C$	337	350	371	mA
		$V_{IN} = 60V$ $V_{LED} = 36V$ IFIX connected to GND $R_{IADJ} = \text{open}$ $T_J = -40^\circ C$ to $125^\circ C$	338	350	374	mA
		$V_{LED} = 24V$ IFIX open $R_{IADJ} = 2.33k\Omega$ $T_J = -40^\circ C$ to $125^\circ C$	437	450	483	mA
		$V_{LED} = 24V$ IFIX open $R_{IADJ} = 3.5 k\Omega$ $T_J = -40^\circ C$ to $125^\circ C$	282	300	316	mA
I_{OCP}	Short circuit output current	$V_{LED} = 0V$ $V_{IN} = 60V$ DIM = open	800	920	1020	mA
I_{LEAK}	LED- pin leakage current	$V_{LED} = 0V$ $V_{IN} = 60V$ DIM = 0V			1.2	μA
V_{DIM}	DIM pin threshold	V_{DIM} increasing		1.0	1.3	V
$V_{DIM-HYS}$	DIM pin hysteresis			0.25		V
f_{SW}	Switching frequency		0.72	0.8	0.92	MHz

NOTES

- (1) The human body model is a 100pF capacitor discharged through a 1.5 k Ω resistor into each pin. The pin 6 (IFIX pin) passes ± 1 kV. Test method is per JESD22-A114S.
- (2) JEDEC J-STD020.
- (3) Min and Max limits are 100% production tested at 25°C. Limits over the operating temperature range are guaranteed through correlation using Statistical Quality Control (SQC) methods.
- (4) Typical numbers are valid at 25°C ambient temperature and represent statistically the utmost probability assuming the Gaussian distribution.
- (5) θ_{JA} measured on a 43.3 mm x 76.2 mm four layer board, with 35 μm copper , thirty five 0.3 mm thermal vias, no air flow, and 1 W power dissipation.

WLMDU9456001JT / 172946001

MagI³C Power Module
LDHM - LED Step Down High Current Module



TYPICAL PERFORMANCE CURVES

If not otherwise specified, the following conditions apply: $V_{IN} = 48V$; $C_{IN}/C_{OUT} = 2.2\mu F$ 100V X7R ceramic capacitor, $I_{LED} = 350mA$; Single LED forward voltage used is 3.2V; $T_{AMB} = 25^{\circ}C$

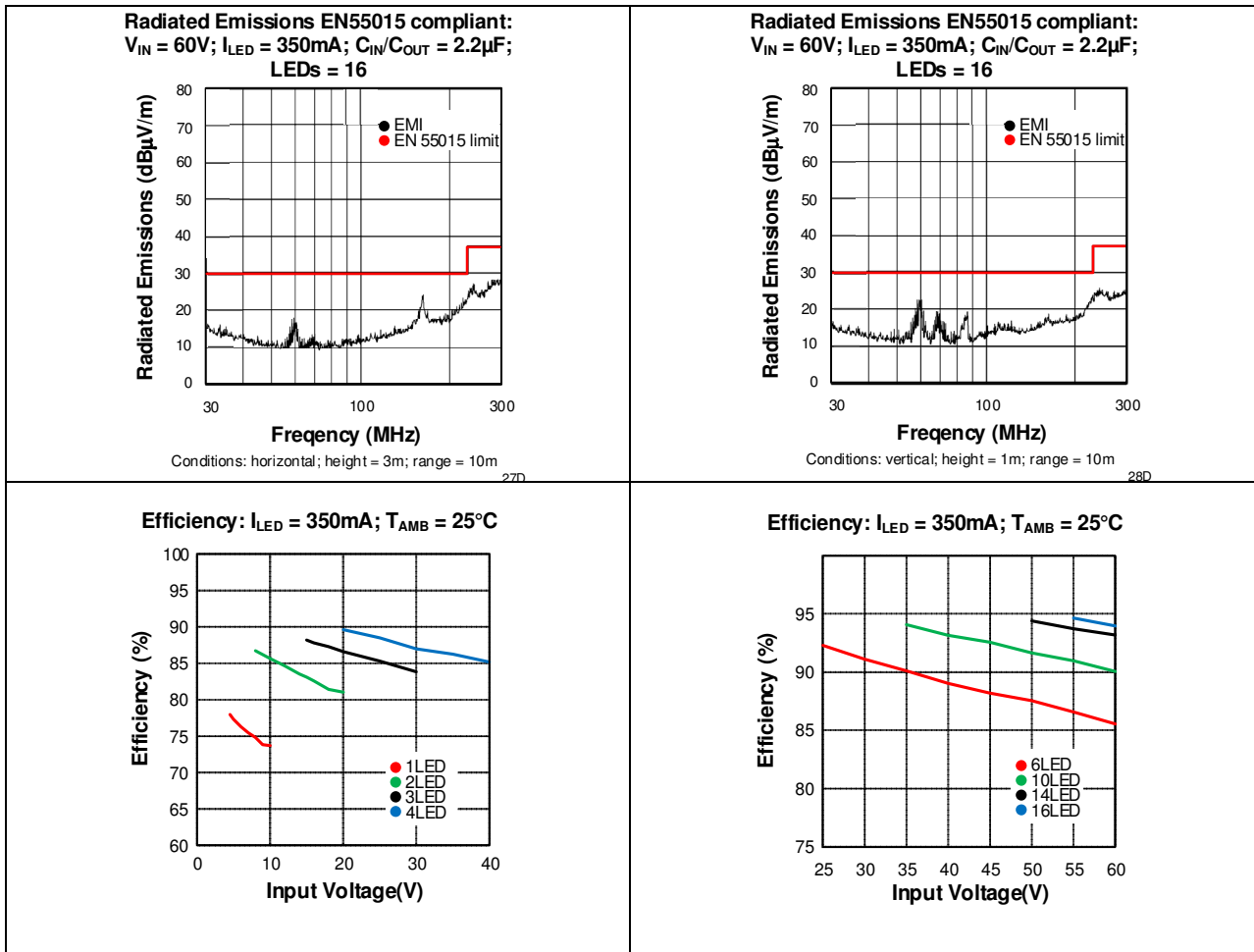

WLMDU9456001JT / 172946001

MagI³C Power Module
LDHM - LED Step Down High Current Module

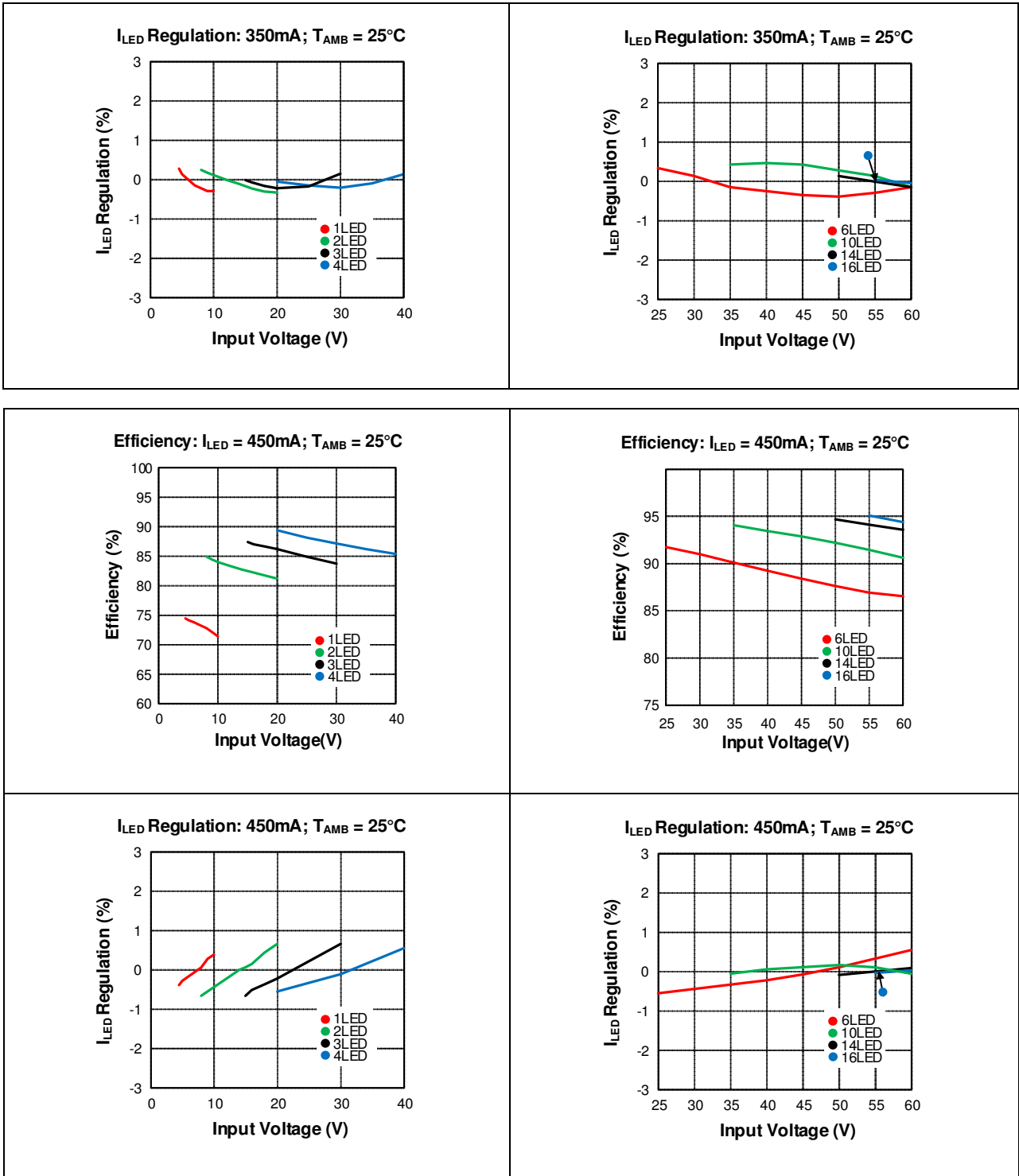

WLMDU9456001JT / 172946001

MagI³C Power Module
LDHM - LED Step Down High Current Module

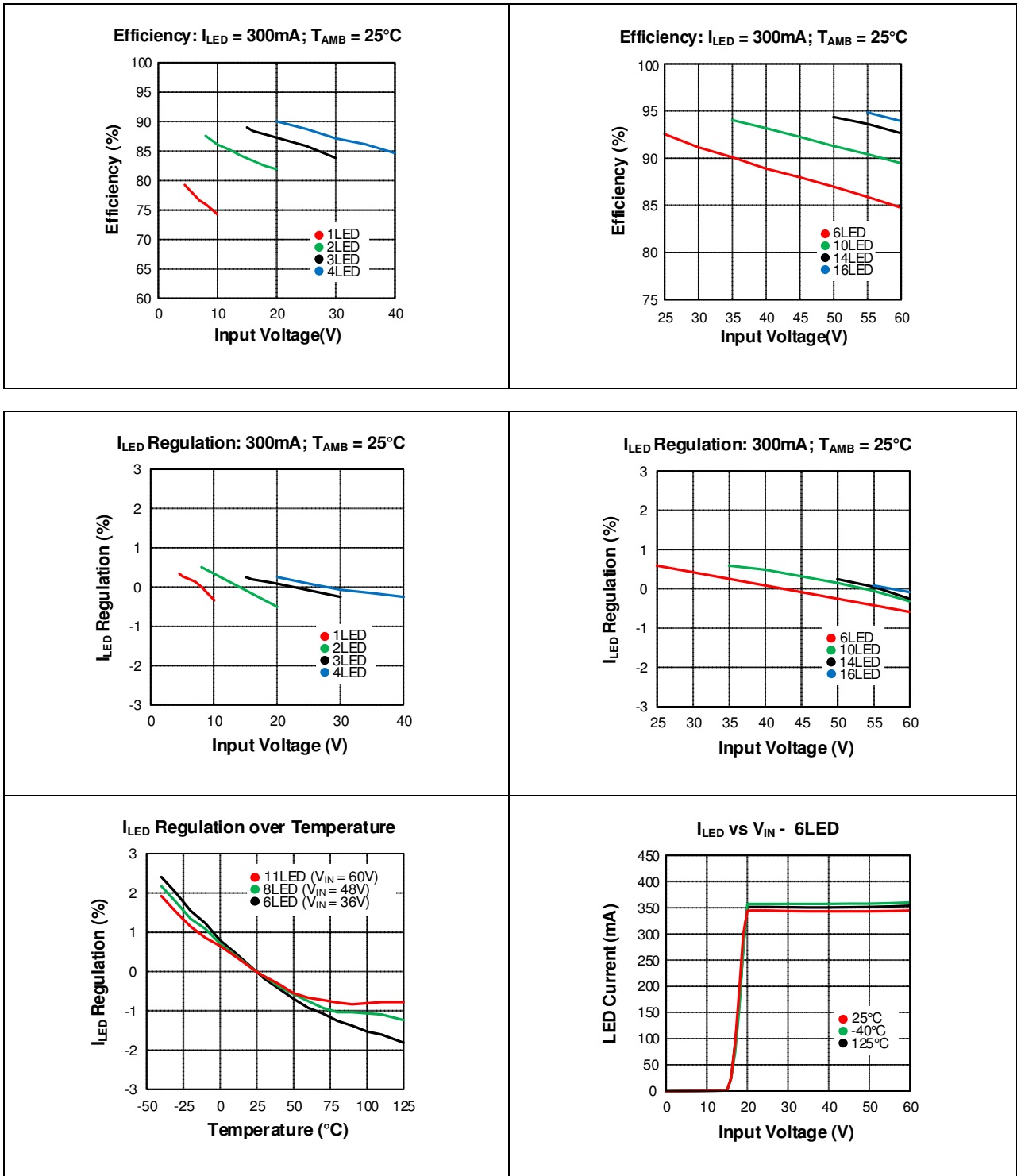

WLMDU9456001JT / 172946001

MagI³C Power Module
LDHM - LED Step Down High Current Module

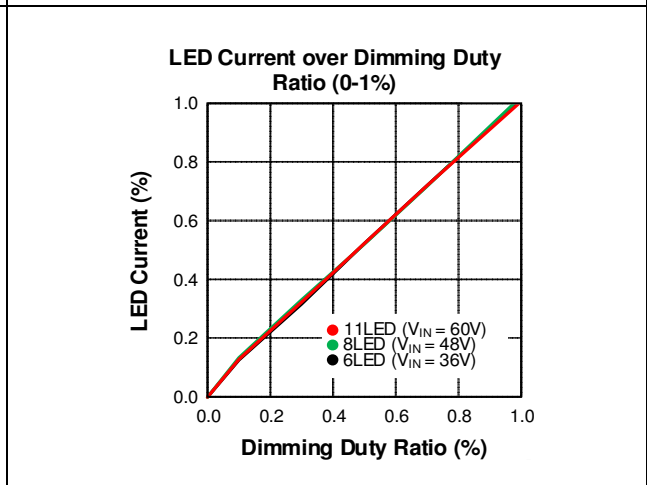
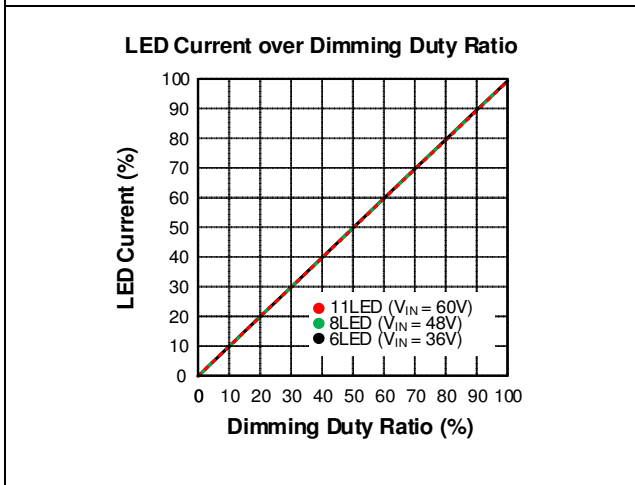
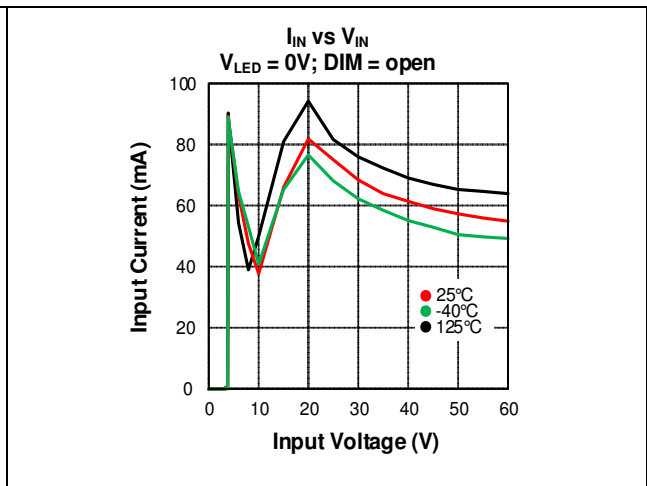
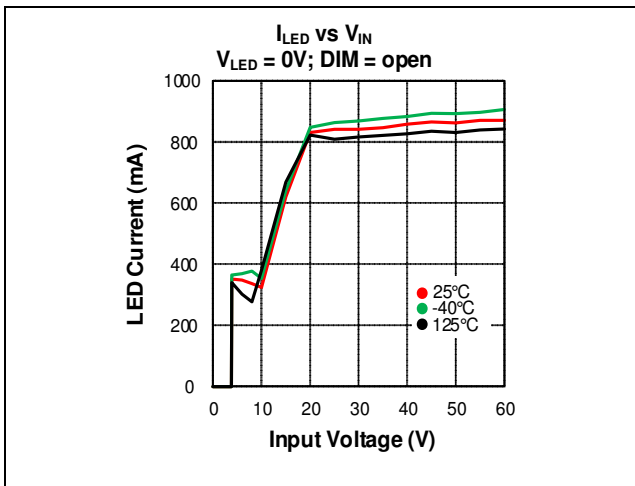
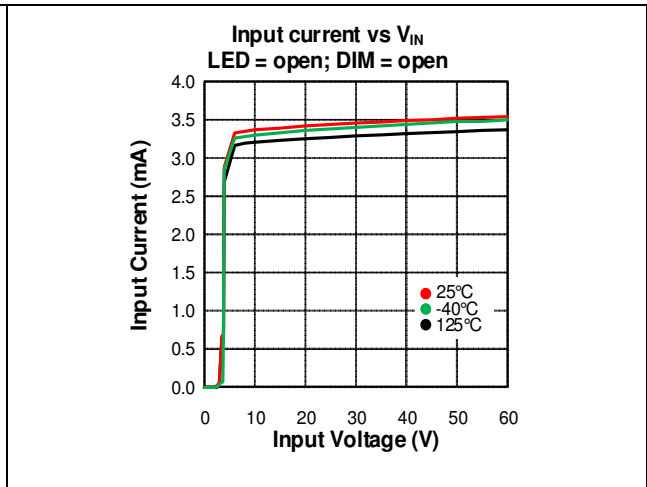
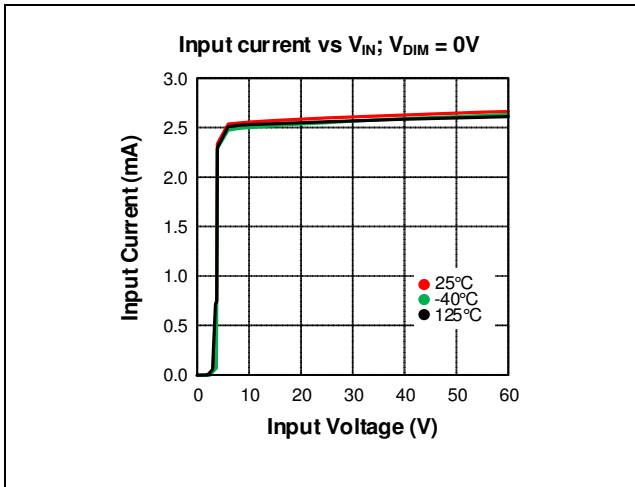

WLMDU9456001JT / 172946001

MagI³C Power Module
LDHM - LED Step Down High Current Module

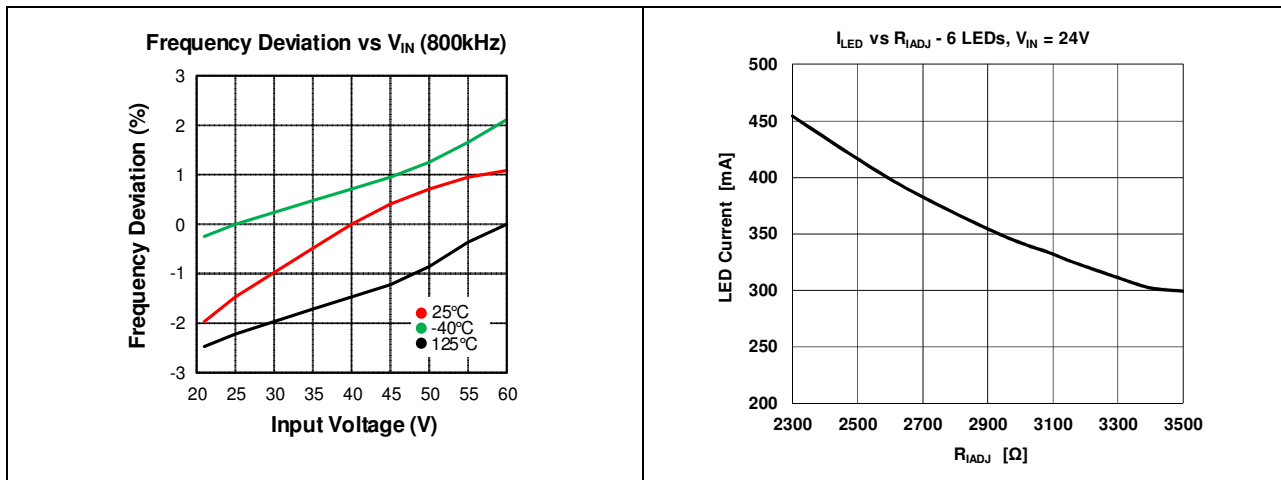

WLMDU9456001JT / 172946001

MagI³C Power Module
LDHM - LED Step Down High Current Module



BLOCK DIAGRAM

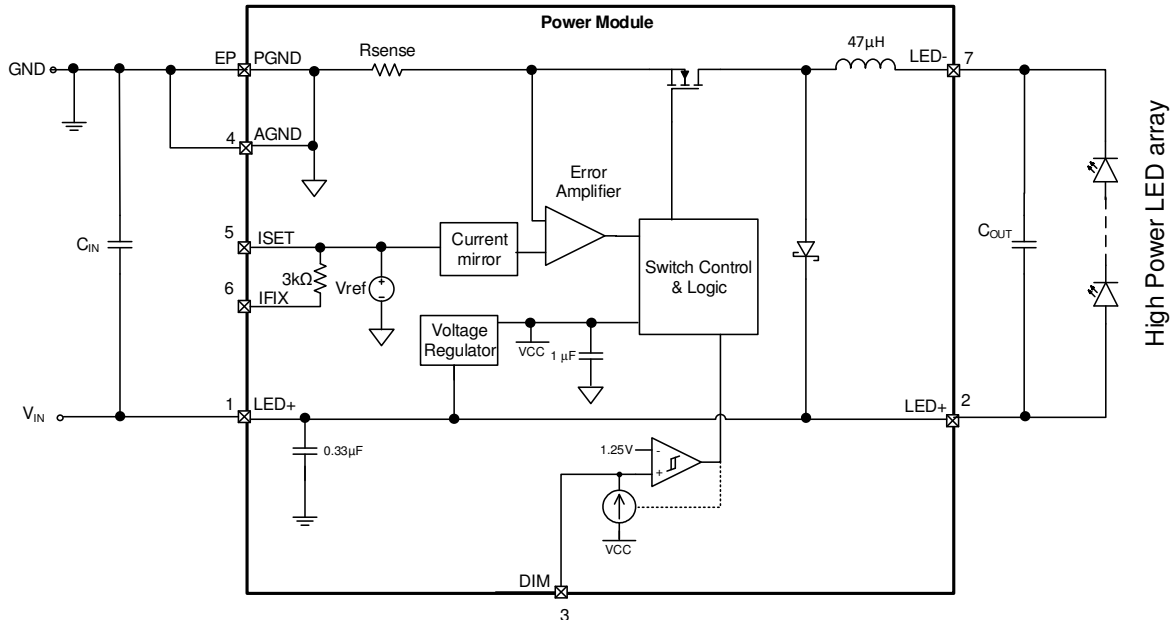

CIRCUIT DESCRIPTION

The MagI³C Power Module 172946001 is based on an asynchronous **floating buck** regulator (simplified schematic below) with an integrated MOSFET, diode and power inductor. Note that, in a floating buck topology the load (in this case LEDs) is not connected to GND. The control loop is based on a current mode control scheme with a fixed switching frequency, assuring accurate constant current regulation and excellent EMI performance. High speed dimming is implemented by direct control of the PWM signal.

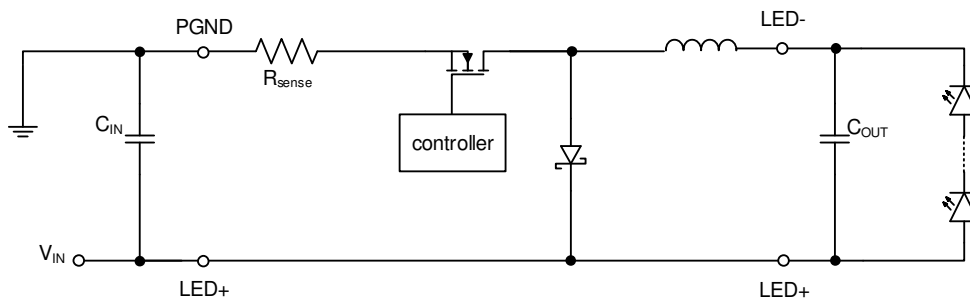

Floating buck

WLMDU9456001JT / 172946001

MagI³C Power Module
LDHM - LED Step Down High Current Module



DESIGN FLOW

The following simple steps will show how to select the external components to design a 172946001 application:

Essential Steps

1. Set the LED current
2. Select the appropriate number of LEDs
3. Layout and EMI considerations

Optional Steps

4. Dimming control
5. Parallel operation

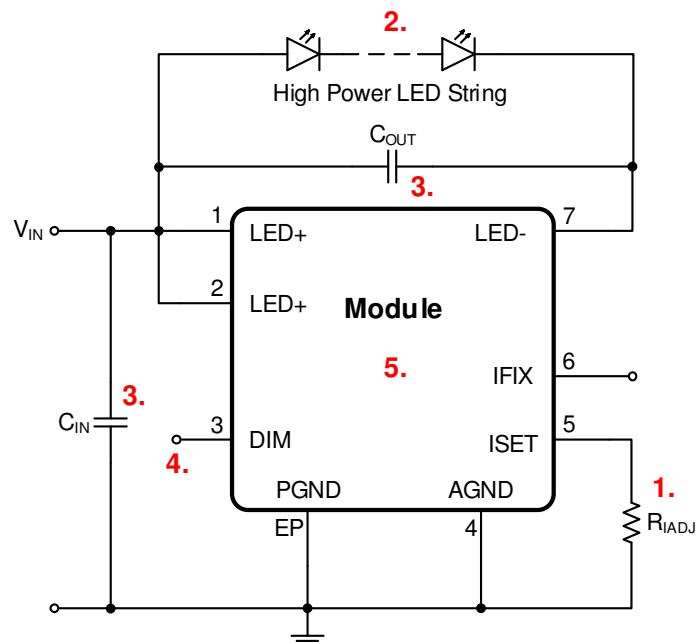

WLMDU9456001JT / 172946001

MagI³C Power Module LDHM - LED Step Down High Current Module



DESIGN FLOW

Step 1 Set the LED Current

The LED driver module requires no external current sensing resistor for LED current regulation. If the default LED current of 350mA is desired, no external components are necessary. It is sufficient to connect the IFIX pin to AGND and to leave the ISET pin open, as shown in the figure below:

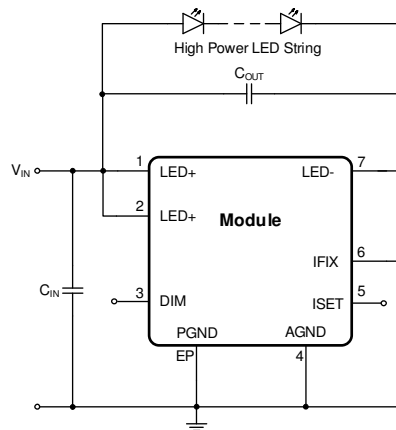

Schematic for 350mA LED current

If a different LED current is required, it can be adjusted from 300mA to 450mA by changing the value of the resistor R_{IADJ} , connected between the ISET pin and AGND, leaving the IFIX pin open, according to the following equation and as shown in the figure on the next page:

$$I_{LED} = \frac{V_{REF} \cdot k}{R_{IADJ}} = \frac{1,25V \cdot 840}{R_{IADJ}} \quad (1)$$

where V_{REF} is the internal voltage reference and k is the current mirror ratio between the LED current and the current flowing through R_{IADJ} . The factor k is fixed by design to 840.

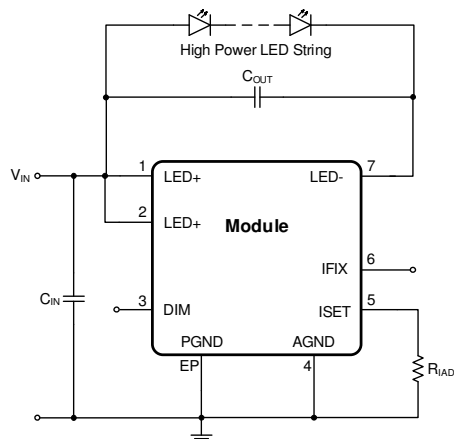

Schematic for adjustable LED current

WLMDU9456001JT / 172946001

MagI³C Power Module
LDHM - LED Step Down High Current Module



DESIGN FLOW

Step 2 Select the appropriate number of LEDs

The on-time of the internal switch should not be shorter than 400ns. In reference to the minimum on time, the number of white LEDs (typical forward voltage of 3.2 V) in relation to the input voltage is shown in the following table.

No. of LED	1	2	3	4	5	6-16
Max. V _{IN} (V)	12	20	30	40	50	60

DESIGN FLOW

Step 3 Layout and EMI considerations

The overall performance of the LED driver module highly depends on the PCB layout. Poor board layout can disrupt the performance of the LED driver module and affect other circuitry by contributing to EMI, ground bounce and resistive voltage drop in the traces. These can send incorrect signals to the LED driver module resulting in poor regulation and stability. By following simple design rules, a good layout can be implemented.

Place C_{IN} as close as possible to the LED+ pin (pin 1 + pin 2) and the PGND exposed pad (EP).

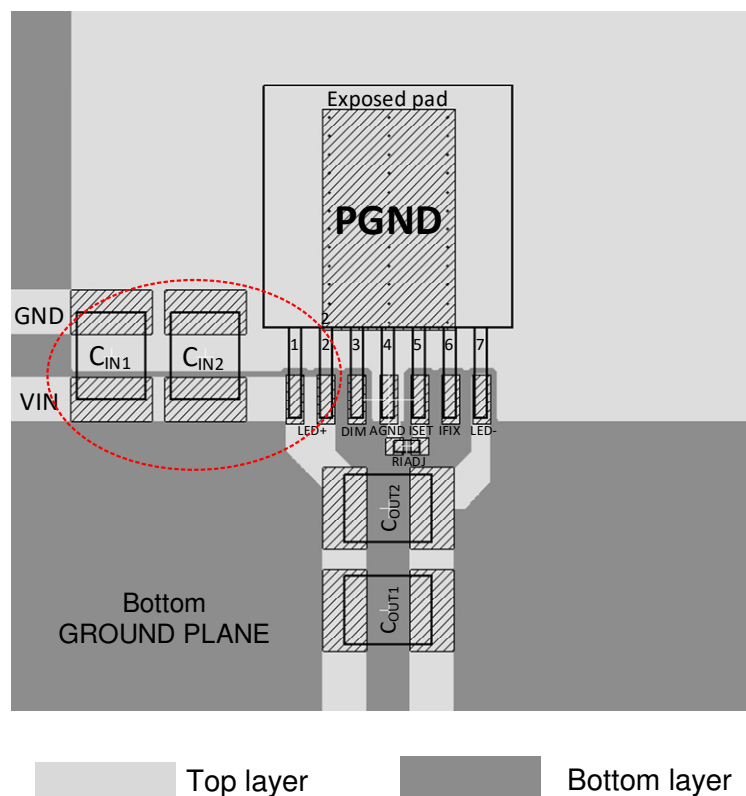

WLMDU9456001JT / 172946001

MagI³C Power Module
LDHM - LED Step Down High Current Module



DESIGN FLOW

Place C_{OUT} (for reduction of LED current ripple and EMI compliance) as close as possible to the LED+ pins (pin 1+pin 2) and the LED- pin (pin 7).

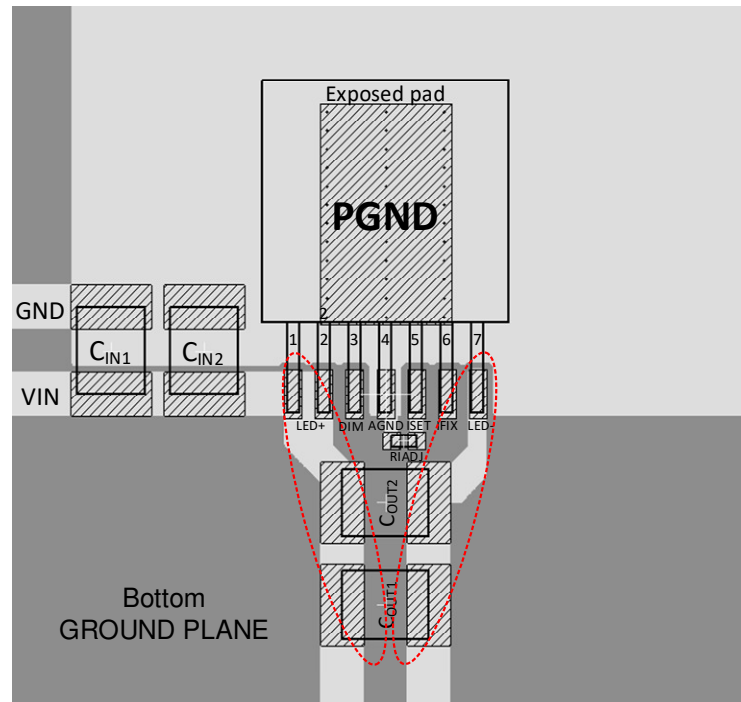

Note:

The illustrated example of the PCB design is subject to the sole consideration of the module. In general, the optimal PCB, land pattern and stencil designs depend on the respective application as well as the specific design rules of the selected PCB manufacturer and assembly service.

WLMDU9456001JT / 172946001

MagI³C Power Module
LDHM - LED Step Down High Current Module



DESIGN FLOW

The PGND exposed pad (EP) is internally connected to the AGND pin (pin 4) directly. Nevertheless, it is recommended to connect these pins by a copper trace.

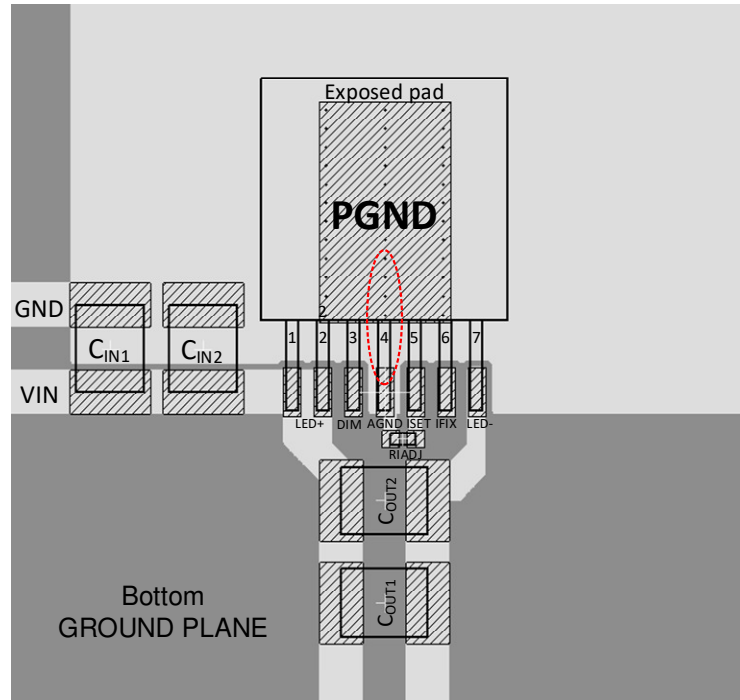

From the EMI reduction point of view, it is imperative to minimize the di/dt current paths (refer to LED driver module current loops schematic below). Therefore, it is recommended to connect a 2.2µF capacitor (C_{OUT}) across the LED+ pin and LED- pin. This will minimize the ripple current, reducing the radiated EMI.

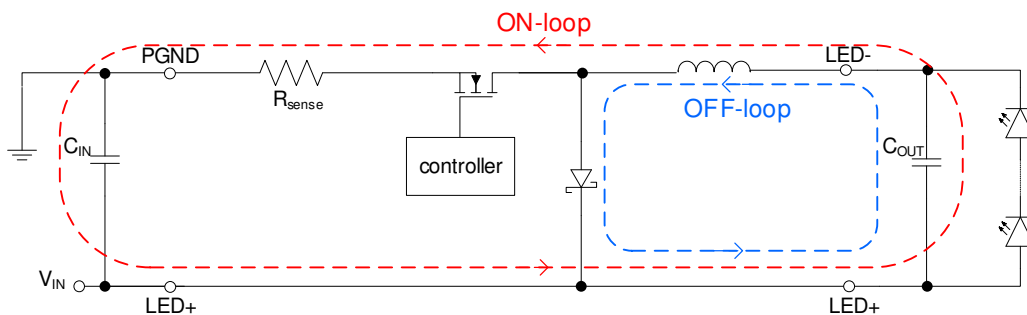

WLMDU9456001JT / 172946001

MagI³C Power Module
LDHM - LED Step Down High Current Module

**LED driver module current loops**

The 172946001 is able to work properly without any COUT. In this case, the inductor ripple will be added to the LED current, as shown in the picture below.

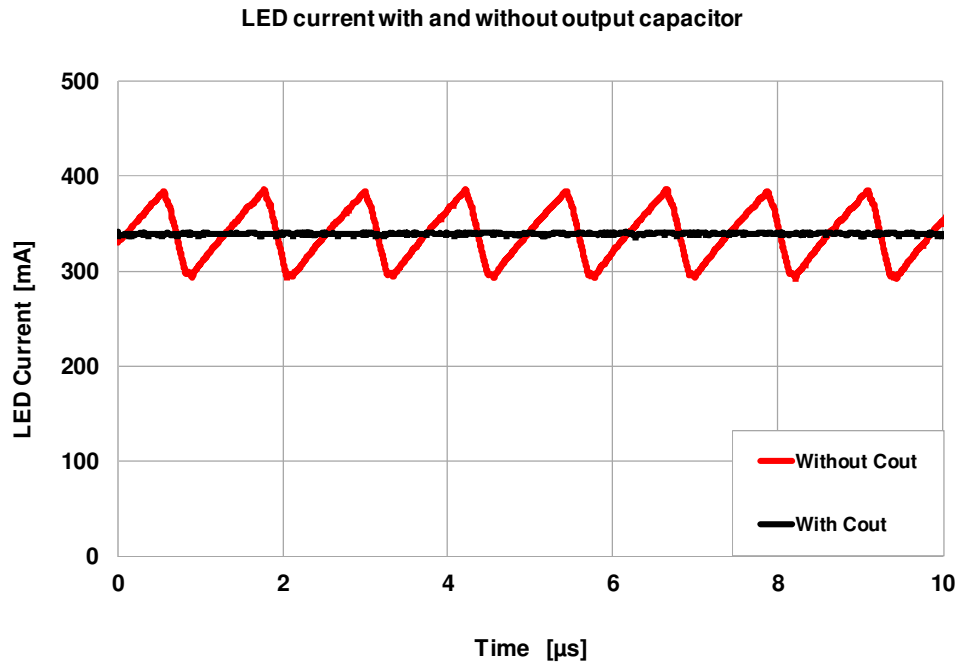

The switching frequency of 800kHz does not lead to visible flickering of the LED light. Without an output capacitor, the inductor ripple will flow through the LED, decreasing its lifetime and efficiency, while increasing the EMI of the system. Therefore a small MLCC output capacitor of 2,2μF is recommended.

WLMDU9456001JT / 172946001

MagI³C Power Module LDHM - LED Step Down High Current Module



Step 4 Dimming Control

Two ways to implement the LED dimming are possible with the WE LDHM: Analog dimming and PWM dimming. Both methods control the current flowing through the LEDs.

Analog dimming

The analog dimming can be achieved by adjusting the LED current while using an external voltage source (V_{ADIM}), as shown in the figure below:

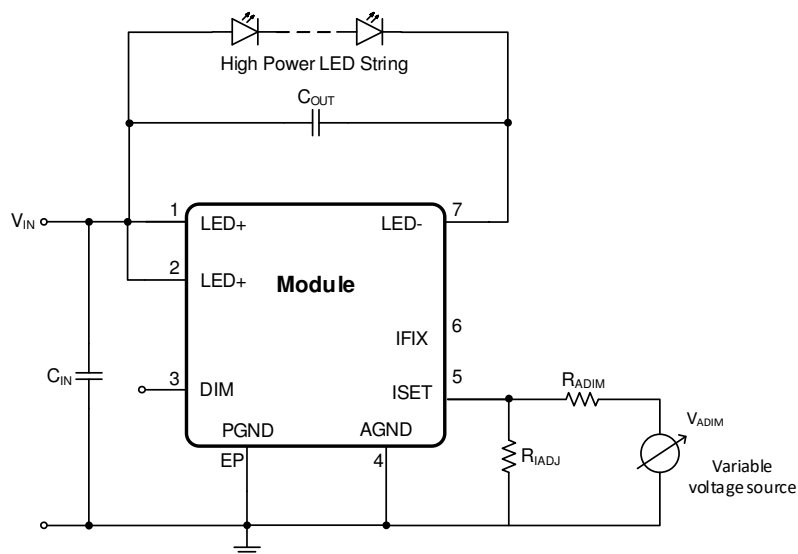

The LED current can be adjusted from $I_{LED,min}$ (300mA) to $I_{LED,max}$ (450mA) by selecting the resistor R_{IADJ} and R_{ADIM} , as described by the following equations:

$$R_{ADIM} = \frac{V_{ADIM} \cdot k}{I_{LED,max} - I_{LED,min}} \quad (3)$$

$$R_{IADJ} = \frac{V_{ADIM} \cdot V_{REF} \cdot k}{V_{ADIM} \cdot I_{LED,max} - V_{REF} \cdot (I_{LED,max} - I_{LED,min})} \quad (4)$$

where $V_{REF} = 1.25V$ and k is the current mirror ratio (internally set to 840).

WLMDU9456001JT / 172946001

MagI³C Power Module LDHM - LED Step Down High Current Module



Example. In the following table, two analog dimming examples are shown using external voltage sources and the corresponding resistors for analog dimming are shown. In both cases the LED current can be adjusted from 300mA to 450mA.

V _{ADIM} range [V]	R _{ADIM} [kΩ]	R _{IADJ} [kΩ]
0 to 3.3	18.48 (18.7 closest value 1% series)	2.67
0 to 5	28.00	2.55

The figure below shows the LED current in relation to the analog dimming voltage.

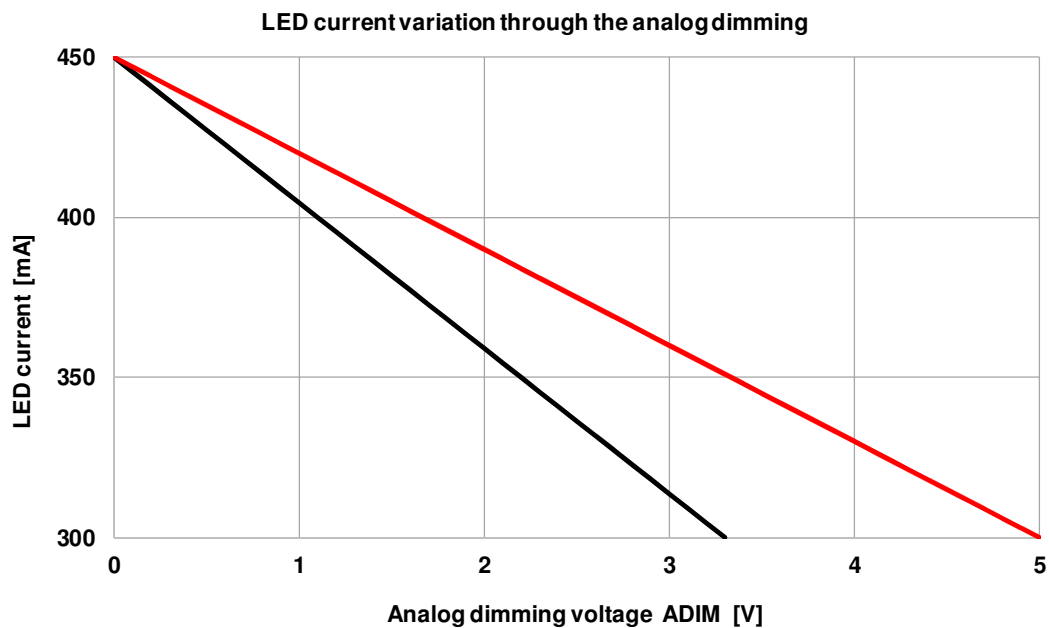

Since the chromaticity coordinates of an LED depends on its current, the analog dimming does not allow to maintain the chromaticity coordinates of the emitted light. For applications where the color of the emitted light plays a crucial role, PWM dimming is strongly recommended to adjust brightness without changing the perceived color of the LED..

WLMDU9456001JT / 172946001

MagI³C Power Module
LDHM - LED Step Down High Current Module

**PWM Dimming**

Adjusting the perceived brightness of an LED while maintaining its chromaticity requires a fixed value of current through the LED. As the human eye is incapable of distinguishing flickering light with frequencies about 120Hz, a PWM dimming solution can allow for a very specific color to be selected and maintained, regardless of the amount of dimming applied.

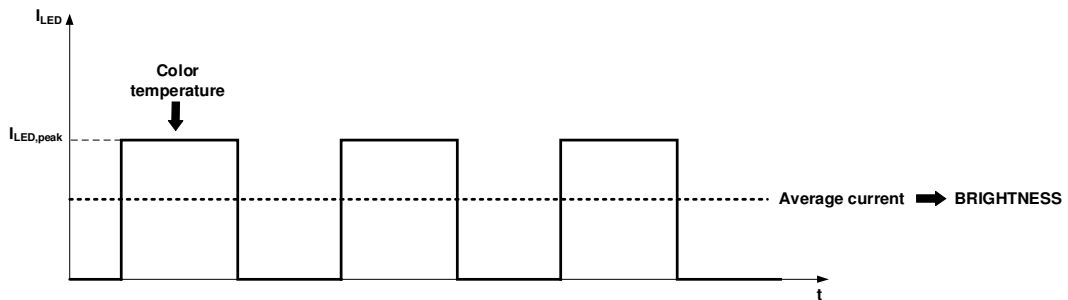

The 172946001 LED driver module offers PWM dimming.

The DIM pin accepts logic signals for average LED current control and has an integrated pull up circuit. Applying a logic high signal (above 1.3V) or leaving the DIM pin open will enable the device. Applying a logic low signal (below 0.7V) will disable the switching activity.

WLMDU9456001JT / 172946001

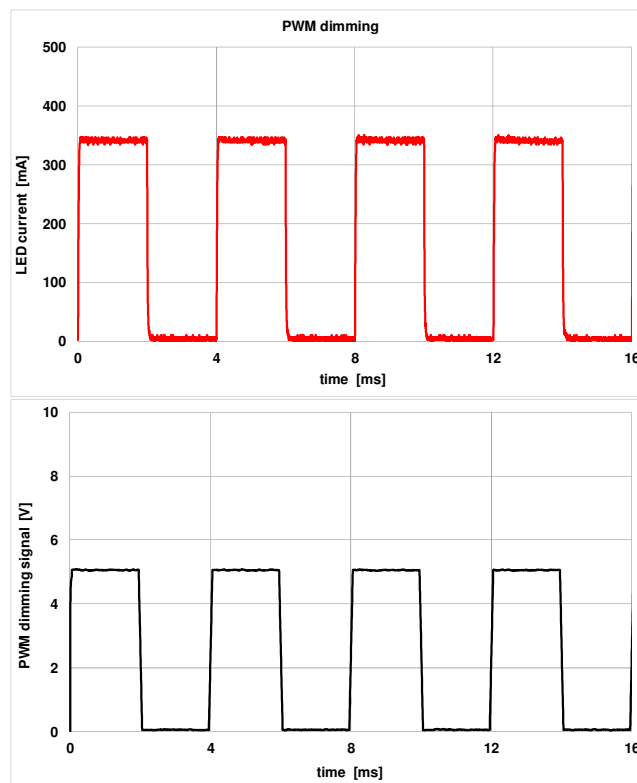
MagI³C Power Module
 LDHM - LED Step Down High Current Module

Example with PWM dimming frequency of 250Hz

As a rule of thumb, the maximum frequency of the PWM dimming signal ($f_{DIM,max}$) should not exceed 1/10 of the switching frequency:

$$f_{SW} = 800\text{kHz} \Rightarrow f_{DIM,max} = 80\text{kHz} \quad (5)$$

The minimum dimming on-time pulse ($t_{DIM,on,min}$) is 16 μs . The frequency of the dimming signal must be adjusted according to the required dimming contrast ratio (CR). The contrast ratio is defined as the number of steps between the minimum (dark) and maximum (full light) brightness of a lighting source.

The higher the CR, the lower the dimming frequency, as described by the equation below:

$$f_{DIM,max} = \frac{1}{t_{DIM,on,min} \cdot CR} \quad (6)$$

Example 1: If a PWM signal is generated by an 8-bit timer of a microcontroller, 256 different steps are available (the achievable contrast ratio would be 256:1). According to equation (6), the following dimming frequency is calculated:

$$f_{DIM} = \frac{1}{16\mu\text{s} \cdot 256} = 244\text{Hz} \quad (7)$$

A PWM dimming frequency of 244Hz can be used. Varying the duty cycle of the PWM signal, 256 different levels of brightness of the LEDs can be achieved, as shown in the figure below:

WLMDU9456001JT / 172946001

MagI³C Power Module LDHM - LED Step Down High Current Module

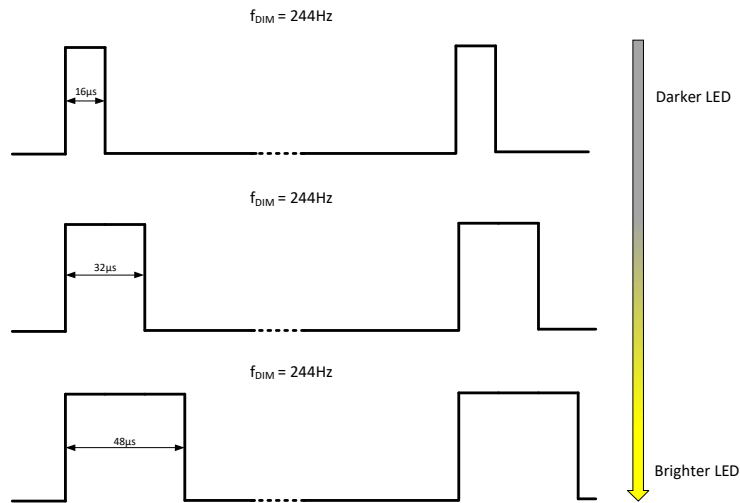

Pulse frequency modulation (PFM) dimming control is possible by setting the on-time pulse of the square signal to the minimum on-time of 16µs and varying the frequency. This will result in different brightness levels as well as contrast ratios, as shown in the figure below:

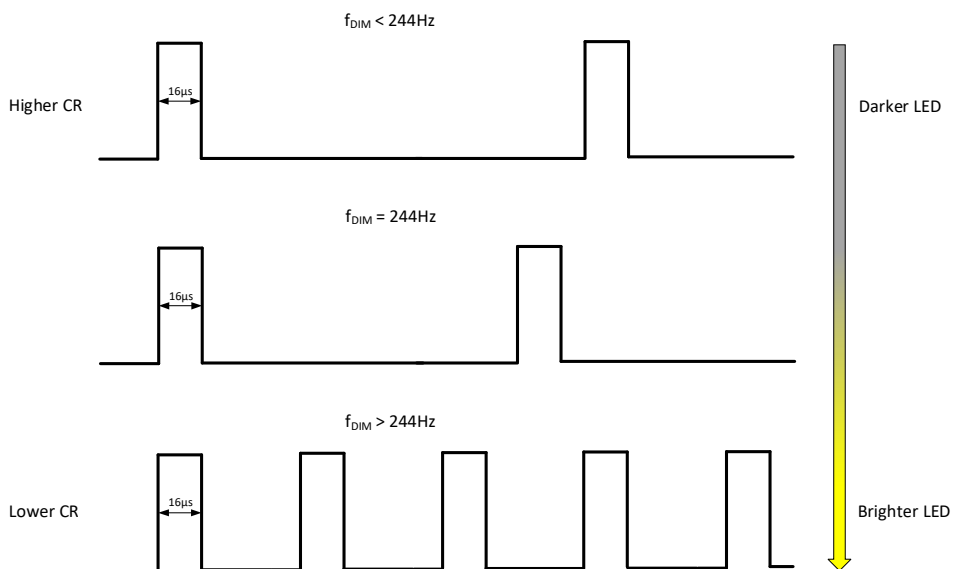

WLMDU9456001JT / 172946001

MagI³C Power Module LDHM - LED Step Down High Current Module



Example 3. The figure below shows a possible combination of analog and PWM dimming in order to set the color temperature of the emitted light and, at the same time, to adjust the brightness.

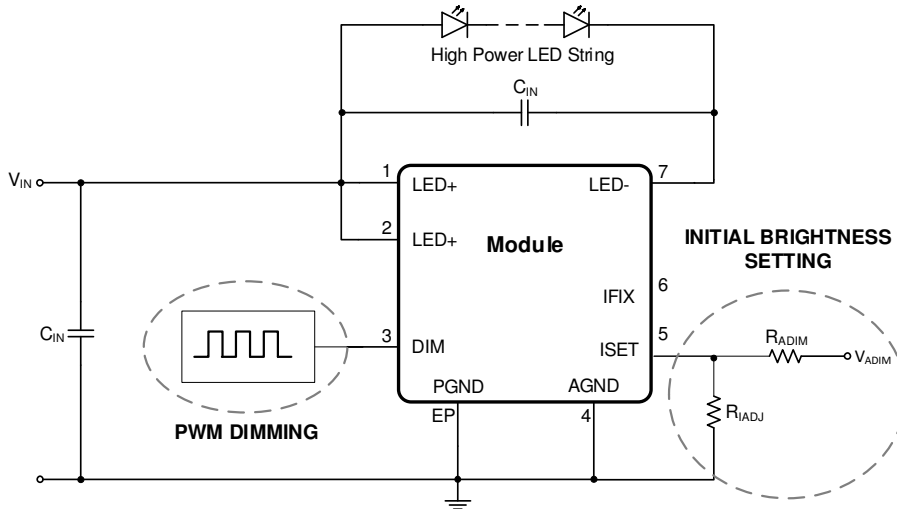

Step 5 Parallel operation

LED driver modules can be used in parallel to deliver higher current, when a load current higher than 450mA is required by the application.. With connected V_{IN} and GND pins, each LED driver module will operate as independent current sources. The total DC current of the modules will be additive; however, low frequency sub-harmonic current ripple may be present and its frequency and magnitude will depend upon the phase relationship between the internal clocks, as there is no possibility for synchronizing the driver clocks. All LDHM LED drivers should have a local C_{IN} capacitor of minimum 2.2 μF 1210 X5R MLCC located as close as possible to V_{IN} and GND.

Parallel operation circuit schematic

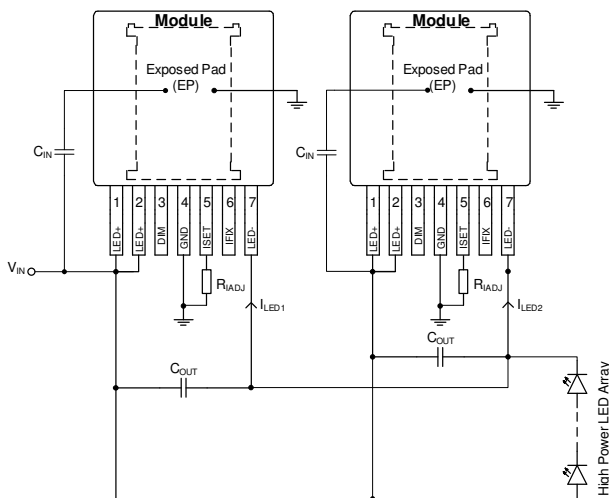

Parallel operation result; $I_{LED} = 900mA$

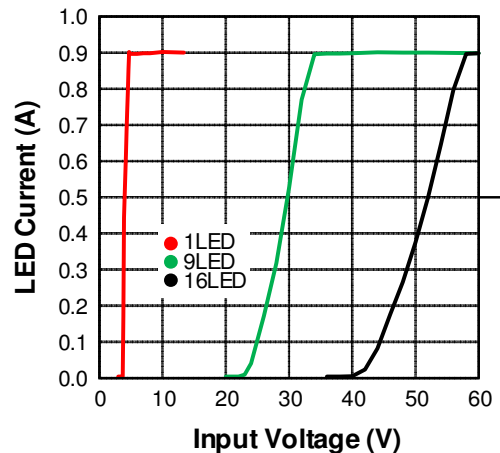

31D

WLMDU9456001JT / 172946001

MagI³C Power Module
LDHM - LED Step Down High Current Module



PROTECTIVE FEATURES

LED short circuit protection

Example

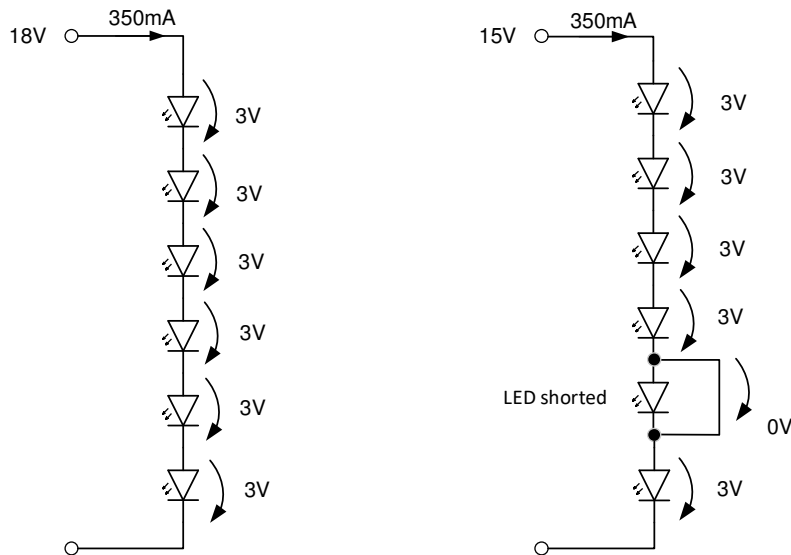

In case of a short circuit of one or more LEDs, the loop will react in order to adapt the voltage across the LED string, as shown in the figure below.

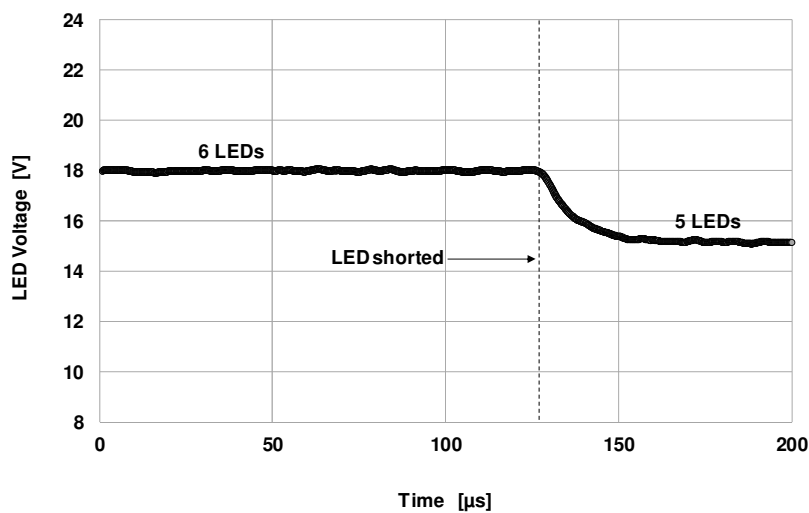

Similarly, in case the LED has a temporary short circuit, the voltage across the LED string will be adjusted accordingly. In any case, the current through the LED string is not affected, keeping the programmed value.

WLMDU9456001JT / 172946001

MagI³C Power Module
LDHM - LED Step Down High Current Module



Open LED behavior

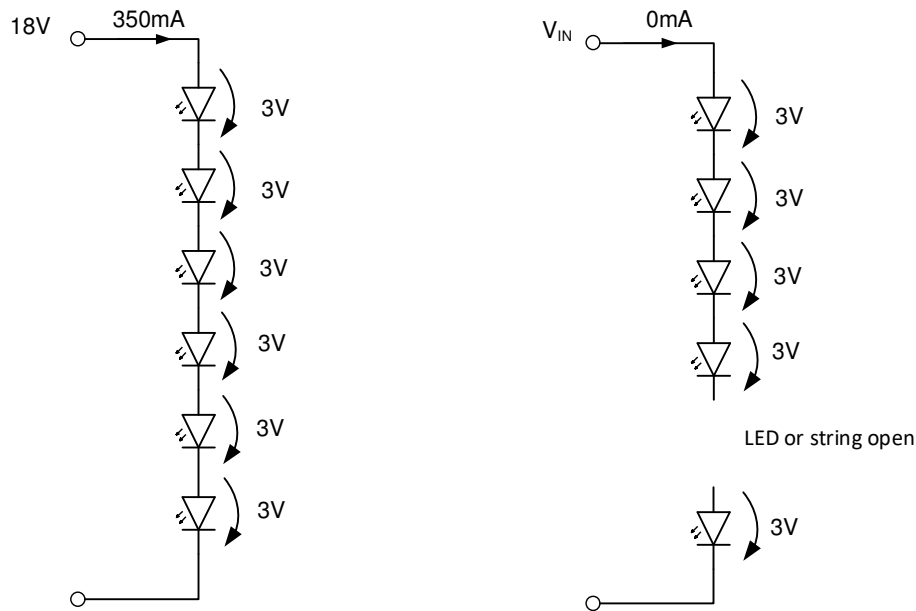

When an LED becomes an open circuit or simply the LED string is disconnected by the LED driver, the current stops flowing through the LED string. As a consequence the control loop will set the voltage between LED+ and LED- to the input voltage (V_{IN}), as shown below:

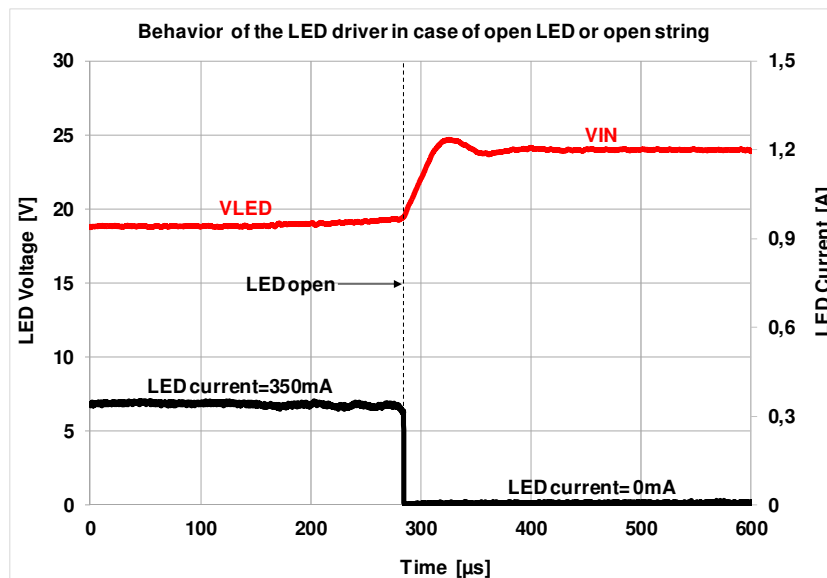

Monitoring the LED string voltage by an external microcontroller allows the detection of defective strings.

WLMDU9456001JT / 172946001

MagI³C Power Module LDHM - LED Step Down High Current Module



APPLICATIONS

The MagI³C LED driver module is an easy-to-use solution capable of driving up to 450mA loads with exceptional power conversion efficiency. It is available in an innovative and robust package that enhances thermal performance and allows for easy hand or machine soldering.

Application Circuit

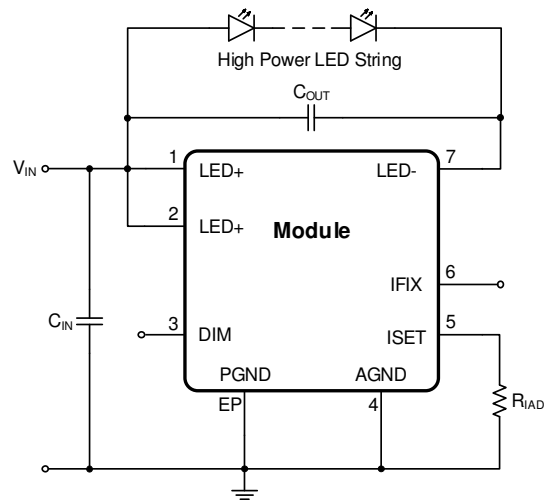

I _{LED}	300mA	350mA	450mA
R _{IADJ}	3.5kΩ	Not connected	2.33kΩ
IFIX pin	open	to GND	open
C _{IN}	2.2 μF ; 100 V ; X7R		
C _{OUT}	2.2 μF ; 100 V ; X7R		

WLMDU9456001JT / 172946001

Mag³C Power Module LDHM - LED Step Down High Current Module



HANDLING RECOMMENDATIONS

1. The power module is classified as MSL3 (JEDEC Moisture Sensitivity Level 3) and requires special handling due to moisture sensitivity (JEDEC J-STD033).
2. The parts are delivered in a sealed bag (Moisture Barrier Bags = MBB) and should be processed within one year.
3. When opening the moisture barrier bag check the Humidity Indicator Card (HIC) for color status. Bake parts prior to soldering in case indicator color has changed according to the notes on the card .
4. Parts must be processed after 168 hour (7 days) of floor life. Once this time has been exceeded, bake parts prior to soldering per JEDEC J-STD033 recommendation.

SOLDER PROFILE

1. Only Pb-Free assembly is recommended according to JEDEC J-STD020.
2. Measure the peak reflow temperature of the Mag³C power module in the middle of the top view.
3. Ensure that the peak reflow temperature does not exceed 240°C ±5°C as per JEDEC J-STD020.
4. The reflow time period during peak temperature of 240°C ±5°C must not exceed 20 seconds.
5. Reflow time above liquidus (217°C) must not exceed 60 seconds.
6. Maximum ramp up is rate 3°C per second
7. Maximum ramp down rate is 6°C per second
8. Reflow time from room temperature (25°C) to peak temperature must not exceed 8 minutes as per JEDEC J-STD020.
9. Maximum number of reflow cycles is two.
10. For minimum risk, solder the module in the last reflow cycle of the PCB production.
11. For soldering process, please consider the lead materials, copper (Cu) and lead finish tin (Sn).
12. For solder paste use a standard SAC Alloy such as SAC 305, type 3 or higher.
13. The profile below is valid for convection reflow only
14. Other soldering methods (e.g. vapor phase) are not verified and have to be validated by the customer at their own risk

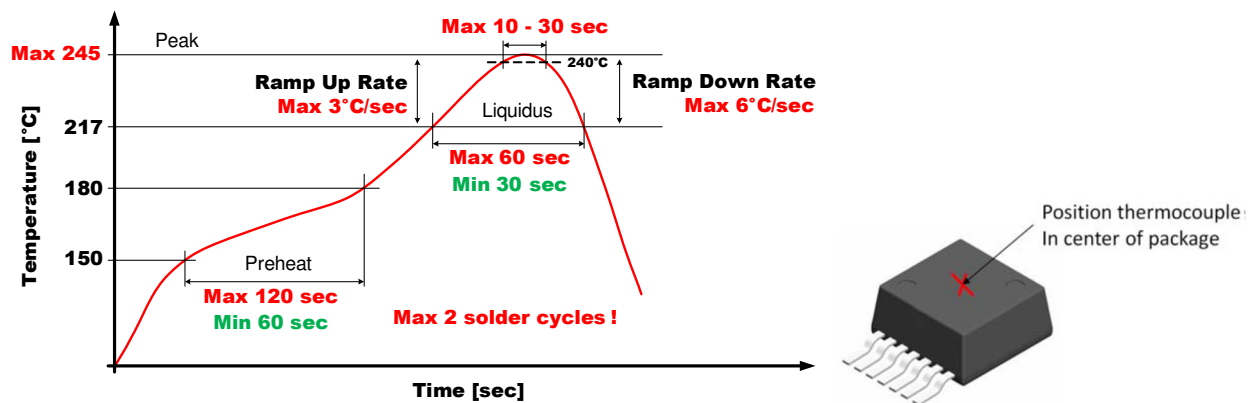

WLMDU9456001JT / 172946001

MagI³C Power Module
LDHM - LED Step Down High Current Module



PHYSICAL DIMENSIONS (mm)

Package Type: TO263-7

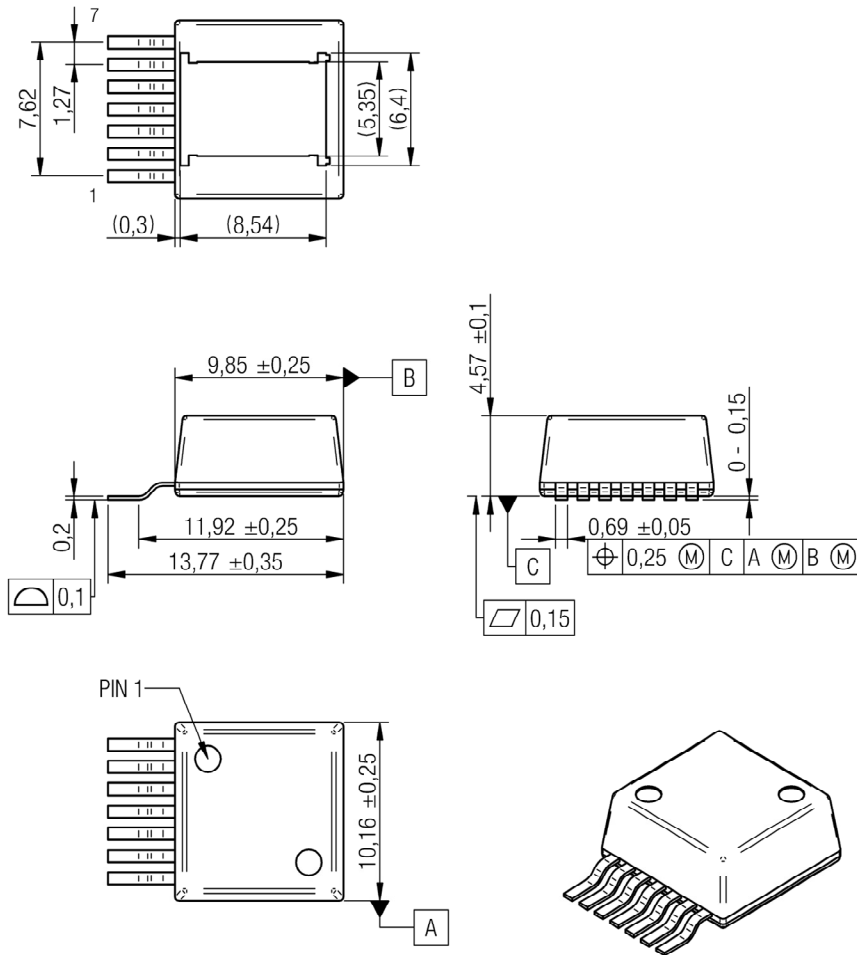

WLMDU9456001JT / 172946001

MagI³C Power Module
LDHM - LED Step Down High Current Module



RECOMMENDED FOOTPRINT DESIGN

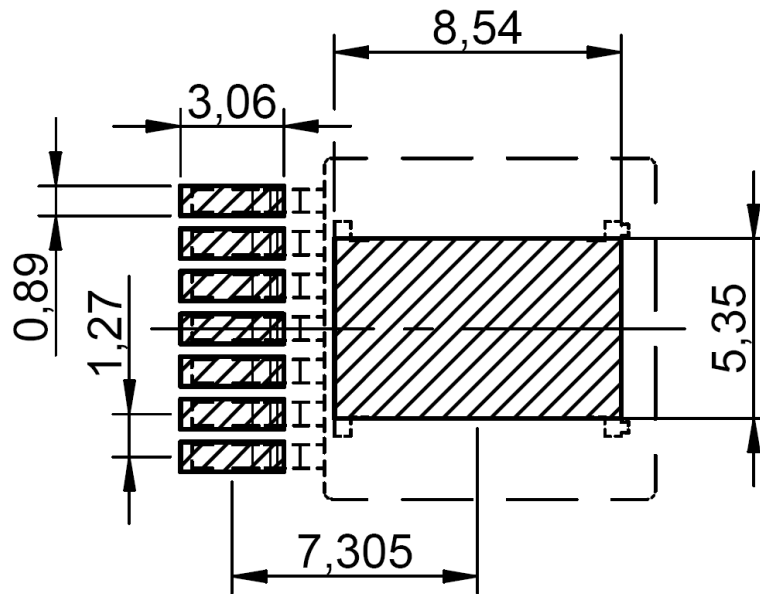

RECOMMENDED SOLDER STENCIL DESIGN

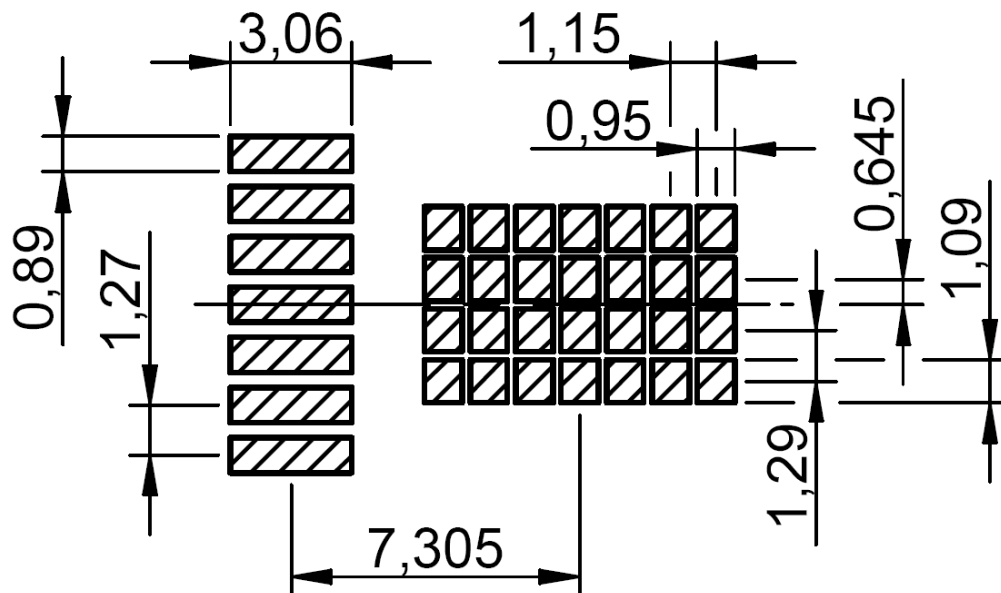

solder paste recommendation 125µm

WLMDU9456001JT / 172946001

MagI³C Power Module
LDHM - LED Step Down High Current Module

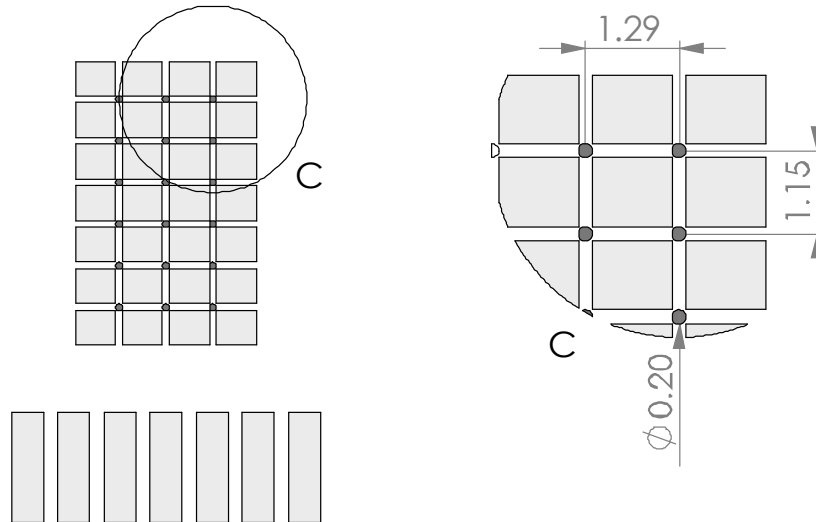
**Recommended Thermal Vias Placement****Place array of heat-sinking vias**

Use an array of heat-sinking vias to connect the PGND pad to the ground plane on the bottom PCB layer. If the PCB has multiple of copper layers, these thermal vias can also be used to make a connection to the heat-spreading ground planes located on inner layers.

For best result, use a thermal via array as proposed in the picture above with drill of max 200 μm , annular ring diameter of 400 μm is recommended, vias spaced 500 μm apart. Ensure enough copper area is used for heat-sinking, to keep the junction temperature below 125°C.

WLMDU9456001JT / 172946001

MagI³C Power Module
LDHM - LED Step Down High Current Module



PACKAGING

Reel (mm)

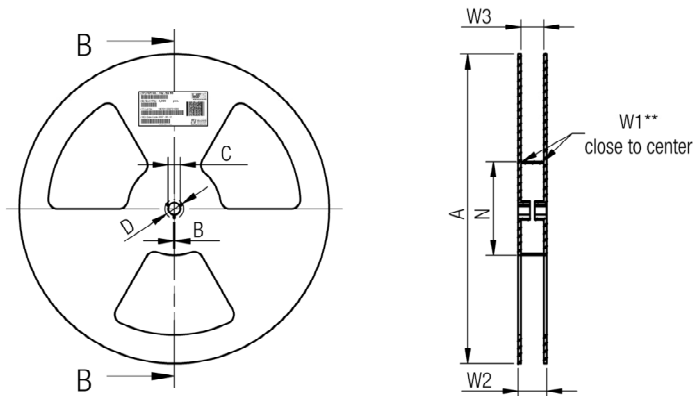

	A	B	C	D	N	W1	W2	W3	W3	
tolerance	± 2,0	min.	± 0,8	min.	± 2,0	+ 2	max.	min.	max.	
Tape width	24mm	330,00	1,50	13,00	20,20	60,00	24,40	30,40	23,90	27,40

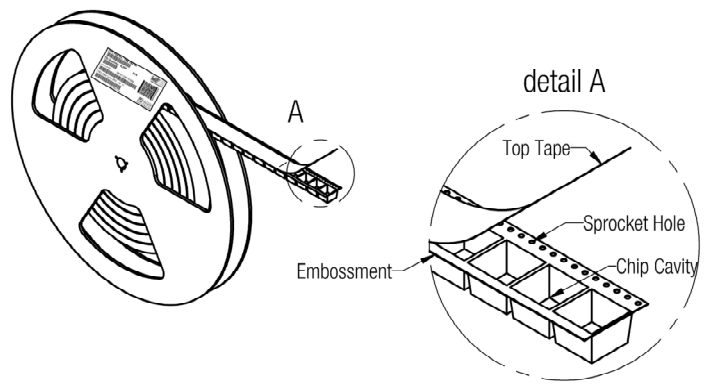

20P

WLMDU9456001JT / 172946001

MagI³C Power Module LDHM - LED Step Down High Current Module



Tape (mm)

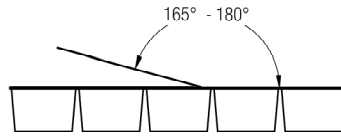

Tape width	24 mm	Pull-of force
		0,1 N - 1,3 N

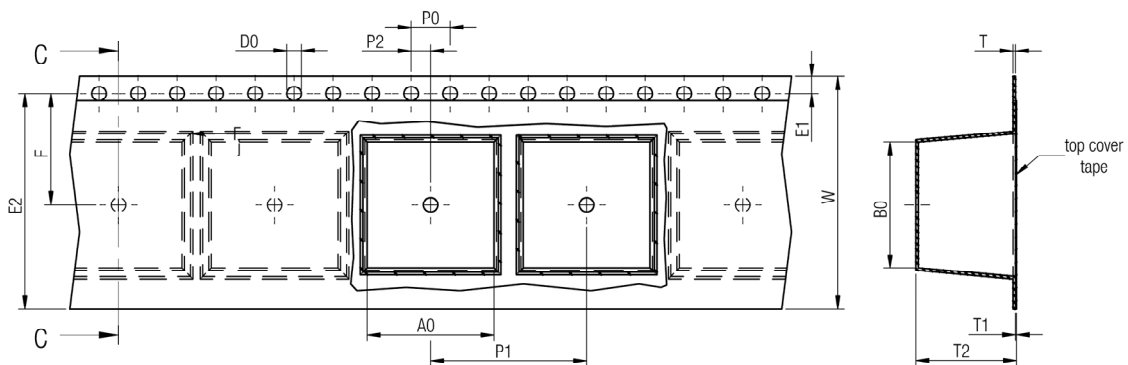

	A0	B0	W	P1	T	T1	T2	D0	E1	E2	F	P0	P2	Tape	VPE / packaging unit	
tolerance	typ.	typ.	+0,3 -0,1	± 0,1	± 0,1	max.	typ.	+0,3 -0,1	± 0,1	min.	± 0,05	± 0,1	± 0,05			
size	TO263-7EP	10,60	14,22	24,00	16,00	0,50	0,10	5,00	1,50	1,75	22,25	11,50	4,00	2,00	Polystyrene	250

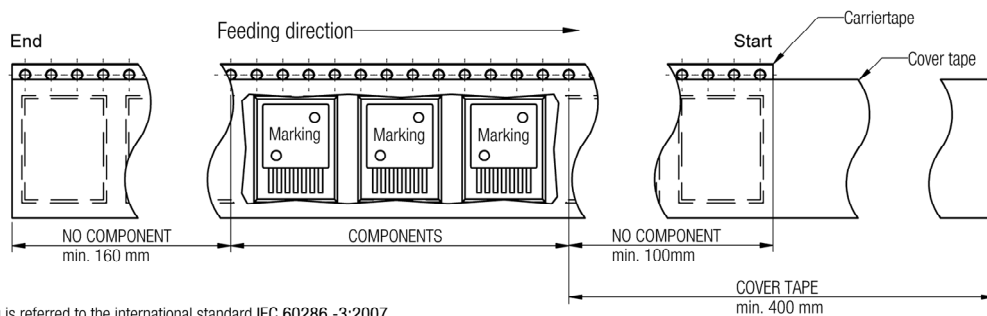

Packaging is referred to the international standard IEC 60286 -3:2007

WLMDU9456001JT / 172946001

MagI³C Power Module
LDHM - LED Step Down High Current Module



DOCUMENT HISTORY

Revision	Date	Description	Comment
1.0	May 2016	Release of final version	
2.0	Nov 2020	Updated version released	Overall update of the datasheet content, e.g.: <ul style="list-style-type: none"> • Symbols in electrical specifications changed • Section of DC LED currents below 300mA removed • Footprint design updated • Stencil design and thermal vias recommendation added • Legal section updated

A CAUTIONS AND WARNINGS

The following conditions apply to all goods within the product series of WE-LDHM of Würth Elektronik eiSos GmbH & Co. KG:

General:

- This electronic component is designed and manufactured for use in general electronic equipment.
- Würth Elektronik must be asked for written approval (following the PPAP procedure) before incorporating the components into any equipment in fields such as military, aerospace, aviation, nuclear control, submarine, transportation (automotive control, train control, ship control), transportation signal, disaster prevention, medical, public information network, etc. where higher safety and reliability are especially required and/or if there is the possibility of direct damage or human injury.
- Electronic components that will be used in safety-critical or high-reliability applications, should be pre-evaluated by the customer.
- The component is designed and manufactured to be used within the datasheet specified values. If the usage and operation conditions specified in the datasheet are not met, the component may be damaged or dissolved.
- Do not drop or impact the components as material of the body, pins or termination may flake apart.
- Würth Elektronik products are qualified according to international standards, which are listed in each product reliability report. Würth Elektronik does not warrant any customer qualified product characteristics beyond Würth Elektronik's specifications, for its validity and sustainability over time.
- All technical specifications for standard products also apply to customer specific products.
- Customer acknowledges and agrees that it is solely responsible for compliance with all legal, regulatory and safety-related requirements concerning its products, and any use of Würth Elektronik eiSos GmbH & Co. KG components in its applications, notwithstanding any applications-related information or support that may be provided by Würth Elektronik eiSos GmbH & Co. KG. Customer represents and agrees that it has all the necessary expertise to create and implement safeguards which anticipate dangerous consequences of failures, monitor failures and their consequences lessen the likelihood of failures that might cause harm and take appropriate remedial actions. Customer will fully indemnify Würth Elektronik eiSos and its representatives against any damages arising out of the use of any Würth Elektronik eiSos GmbH & Co. KG components in safety-critical applications.

Product specific:

Follow all instructions mentioned in the datasheet, especially.

Soldering:

- The solder profile must comply with the technical product specifications. All other profiles will void the warranty.
- All other soldering methods are at the customers' own risk.
- Strong forces which may affect the coplanarity of the components' electrical connection with the PCB (i.e. pins), can damage the part, resulting in avoid of the warranty.

WLMDU9456001JT / 172946001

MagI³C Power Module
LDHM - LED Step Down High Current Module



Cleaning and Washing:

- Residual washing varnish agent that is used during the production to clean the application might change the characteristics of the body, pins or termination. The washing varnish agent may have a negative effect on the long term function of the component.
- Using a brush during the cleaning process may break the component. Therefore, we do not recommend using a brush during the PCB cleaning process.

Potting:

- If the component is potted in the customer application, the potting material might shrink or expand during and after hardening. Shrinking could lead to an incomplete seal, allowing contaminants into the component. Expansion could damage the components or parts of it. We recommend a manual inspection after potting to avoid these effects.
- Conformal coating may affect the product performance.

Storage Conditions:

- A storage of Würth Elektronik products for longer than 12 months is not recommended. Within other effects, the terminals may suffer degradation, resulting in bad solderability. Therefore, all products shall be used within the period of 12 months based on the day of shipment.
- Do not expose the components to direct sunlight.
- The storage conditions in the original packaging are defined according to DIN EN 61760-2.
- For a moisture sensitive component, the storage condition in the original packaging is defined according to IPC/JEDEC-J-STD-033. It is also recommended to return the component to the original moisture proof bag and reseal the moisture proof bag again.
- ESD prevention methods need to be followed for manual handling and processing by machinery.
- The storage conditions stated in the original packaging apply to the storage time and not to the transportation time of the components.

Packaging:

- The packaging specifications apply only to purchase orders comprising whole packaging units. If the ordered quantity exceeds or is lower than the specified packaging unit, packaging in accordance with the packaging specifications cannot be ensured.

Handling:

- Violation of the technical product specifications such as exceeding the absolute maximum ratings will void the warranty and also the conformance to regulatory requirements.
- The edge castellation is designed and made for prototyping, i.e. hand soldering purposes, only.
- The applicable country regulations and specific environmental regulations must be observed.
- Do not disassemble the component. Evidence of tampering will void the warranty.
- The temperature rise of the component must be taken into consideration. The operating temperature is comprised of ambient temperature and temperature rise of the component.

The operating temperature of the component shall not exceed the maximum temperature specified.

- Direct mechanical impact to the component must be prevented as the material of the body, pins or termination could flake or, in the worst case, could break. As these devices are sensitive to electrostatic discharge, proper IC Handling Procedures must be followed.

These cautions and warnings comply with the state of the scientific and technical knowledge and are believed to be accurate and reliable. However, no responsibility is assumed for inaccuracies or incompleteness.

WLMDU9456001JT / 172946001

MagI³C Power Module
LDHM - LED Step Down High Current Module



B IMPORTANT NOTES

The following conditions apply to all goods within the product range of Würth Elektronik eiSos GmbH & Co. KG:

1. General Customer Responsibility

Some goods within the product range of Würth Elektronik eiSos GmbH & Co. KG contain statements regarding general suitability for certain application areas. These statements about suitability are based on our knowledge and experience of typical requirements concerning the areas, serve as general guidance and cannot be estimated as binding statements about the suitability for a customer application. The responsibility for the applicability and use in a particular customer design is always solely within the authority of the customer. Due to this fact it is up to the customer to evaluate, where appropriate to investigate and decide whether the device with the specific product characteristics described in the product specification is valid and suitable for the respective customer application or not. Accordingly, the customer is cautioned to verify that the datasheet is current before placing orders.

2. Customer Responsibility related to Specific, in particular Safety-Relevant Applications

It has to be clearly pointed out that the possibility of a malfunction of electronic components or failure before the end of the usual lifetime cannot be completely eliminated in the current state of the art, even if the products are operated within the range of the specifications. In certain customer applications requiring a very high level of safety and especially in customer applications in which the malfunction or failure of an electronic component could endanger human life or health it must be ensured by most advanced technological aid of suitable design of the customer application that no injury or damage is caused to third parties in the event of malfunction or failure of an electronic component.

3. Best Care and Attention

Any product-specific notes, warnings and cautions must be strictly observed. Any disregard will result in the loss of warranty.

4. Customer Support for Product Specifications

Some products within the product range may contain substances which are subject to restrictions in certain jurisdictions in order to serve specific technical requirements. Necessary information is available on request. In this case the field sales engineer or the internal sales person in charge should be contacted who will be happy to support in this matter.

5. Product R&D

Due to constant product improvement product specifications may change from time to time. As a standard reporting procedure of the Product Change Notification (PCN) according to the JEDEC-Standard we inform about minor and major changes. In case of further queries regarding the PCN, the field sales engineer or the internal sales person in charge should be contacted. The basic responsibility of the customer as per Section 1 and 2 remains unaffected.

6. Product Life Cycle

Due to technical progress and economical evaluation we also reserve the right to discontinue production and delivery of products. As a standard reporting procedure of the Product Termination Notification (PTN) according to the JEDEC-Standard we will inform at an early stage about inevitable product discontinuance. According to this we cannot guarantee that all products within our product range will always be available. Therefore it needs to be verified with the field sales engineer or the internal sales person in charge about the current product availability expectancy before or when the product for application design-in disposal is considered. The approach named above does not apply in the case of individual agreements deviating from the foregoing for customer-specific products.

7. Property Rights

All the rights for contractual products produced by Würth Elektronik eiSos GmbH & Co. KG on the basis of ideas, development contracts as well as models or templates that are subject to copyright, patent or commercial protection supplied to the customer will remain with Würth Elektronik eiSos GmbH & Co. KG. Würth Elektronik eiSos GmbH & Co. KG does not warrant or represent that any license, either expressed or implied, is granted under any patent right, copyright, mask work right, or other intellectual property right relating to any combination, application, or process in which Würth Elektronik eiSos GmbH & Co. KG components or services are used.

8. General Terms and Conditions

Unless otherwise agreed in individual contracts, all orders are subject to the current version of the "General Terms and Conditions of Würth Elektronik eiSos Group", last version available at www.we-online.com.

Mouser Electronics

Authorized Distributor

Click to View Pricing, Inventory, Delivery & Lifecycle Information:

[Wurth Elektronik:](#)

[172946001](#)