

### Description

The [SP483E](#) is a half-duplex transceiver that meets the specifications of RS-485 and RS-422 serial protocols with enhanced ESD performance. The ESD tolerance has been improved on these devices to over  $\pm 15\text{kV}$  for both Human Body Model and IEC61000-4-2 Air Discharge Method. This device is pin-to-pin compatible with MaxLinear's SP483 device as well as popular industry standards. As with the original versions, the SP483E feature MaxLinear's BiCMOS design allowing low power operation without sacrificing performance. The SP483E is internally slew rate limited to reduce EMI and can meet the requirements of RS-485 and RS-422 up to 250kbps. The SP483E is also equipped with a low power shutdown mode.

### FEATURES

- 5V only
- Low power BiCMOS
- Driver / receiver enable for multi-drop configurations
- Enhanced ESD specifications:
  - $\pm 15\text{kV}$  Human Body Model
  - $\pm 15\text{kV}$  IEC61000-4-2 Air Discharge
  - $\pm 8\text{kV}$  IEC61000-4-2 Contact Discharge
- Low EMI transceiver limited to 250kbps
- Low power  $1\mu\text{A}$  shutdown mode

Ordering Information - [Back Page](#)

### Block Diagram

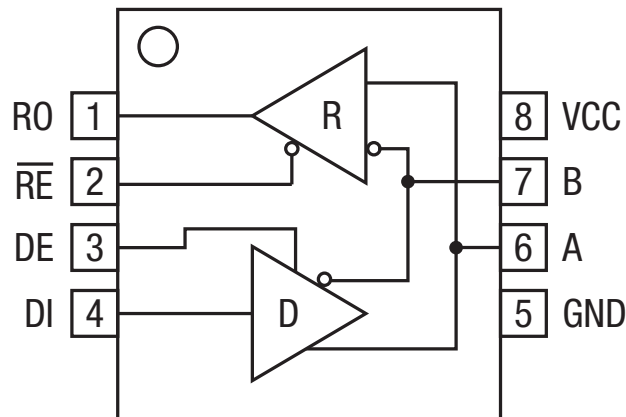

SP483E

## Absolute Maximum Ratings

These are stress ratings only and functional operation of the device at these ratings or any other above those indicated in the operation sections of the specifications below is not implied. Exposure to absolute maximum rating conditions for extended periods of time may affect reliability.

$V_{CC}$  ..... 7.0V

### Input Voltages

Logic ..... -0.3V to ( $V_{CC} + 0.5V$ )

Drivers ..... -0.3V to ( $V_{CC} + 0.5V$ )

Receivers.....  $\pm 15V$

### Output Voltages

Logic ..... -0.3V to ( $V_{CC} + 0.5V$ )

Drivers .....  $\pm 15V$

Receivers.....-0.3V to ( $V_{CC} + 0.5V$ )

Storage Temperature .....-65°C to +150°C

Power Dissipation..... 500mW

## Electrical Characteristics

$T_{AMB} = T_{MIN}$  to  $T_{MAX}$  and  $V_{CC} = 5V \pm 5\%$  unless otherwise noted.

PARAMETERS	MIN.	TYP.	MAX.	UNITS	CONDITIONS
<b>SP483E Driver DC Characteristics</b>					
Differential output voltage			$V_{CC}$	V	Unloaded; $R = \infty\Omega$ ; Figure 1
Differential output voltage	2		$V_{CC}$	V	With load; $R = 50\Omega$ (RS-422); Figure 1
Differential output voltage	1.5		$V_{CC}$	V	With load; $R = 27\Omega$ (RS-485); Figure 1
Change in magnitude of driver differential output voltage for complimentary states			0.2	V	$R = 27\Omega$ or $R = 50\Omega$ ; Figure 1
Driver common-mode output voltage			3	V	$R = 27\Omega$ or $R = 50\Omega$ ; Figure 1
Input high voltage	2.0			V	Applies to DE, DI, $\overline{RE}$
Input low voltage			0.8	V	Applies to DE, DI, $\overline{RE}$
Input current, driver input			10	$\mu A$	Applies to,DI
Input current, control lines			1	$\mu A$	Applies to,DE, $\overline{RE}$
Driver short circuit current $V_{OUT} = HIGH$			$\pm 250$	mA	$-7V \leq V_O \leq 12V$
Driver short circuit current $V_{OUT} = LOW$			$\pm 250$	mA	$-7V \leq V_O \leq 12V$

## Electrical Characteristics (Continued)

$T_{AMB} = T_{MIN}$  to  $T_{MAX}$  and  $V_{CC} = 5V \pm 5\%$  unless otherwise noted.

PARAMETERS	MIN.	TYP.	MAX.	UNITS	CONDITIONS
<b>SP483E Driver AC Characteristics</b>					
Maximum data rate	250			kbps	$\overline{RE} = 5V, DE = 5V; R_{DIFF} = 54\Omega, C_{L1} = C_{L2} = 100pF$
Driver input to output, $t_{PLH}$	250	800	2000	ns	See Figures 3 & 5, $R_{DIFF} = 54\Omega, C_{L1} = C_{L2} = 100pF$
Driver input to output, $t_{PHL}$	250	800	2000	ns	See Figures 3 & 5, $R_{DIFF} = 54\Omega, C_{L1} = C_{L2} = 100pF$
Driver skew		100	800	ns	See Figures 3 and 5, $t_{SKEW} =  t_{DPHL} - t_{DPLH} $
Driver rise or fall time	250		2000	ns	From 10%-90%; $R_{DIFF} = 54\Omega, C_{L1} = C_{L2} = 100pF$ ; See Figures 3 and 6
Driver enable to output high	250		2000	ns	$C_L = 100pF$ , See Figures 4 and 6, $S_2$ closed
Driver enable to output low	250		2000	ns	$C_L = 100pF$ , See Figures 4 and 6, $S_1$ closed
Driver disable time from high	300		3000	ns	$C_L = 15pF$ , See Figures 4 and 6, $S_2$ closed
Driver disable time from low	300		3000	ns	$C_L = 15pF$ , See Figures 4 and 6, $S_1$ closed
<b>SP483E Receiver DC Characteristics</b>					
Differential input threshold	-0.2		0.2	Volts	$-7V \leq V_{CM} \leq 12V$
Input hysteresis		20		mV	$V_{CM} = 0V$
Output voltage HIGH	3.5			Volts	$V_{ID} = 200mV, I_O = -4mA$
Output voltage LOW			0.4	Volts	$V_{ID} = 200mV, I_O = 4mA$
Three-state ( high impedance) output current			$\pm 1$	$\mu A$	$0.4V \leq V_O \leq 2.4V; \overline{RE} = 5V$
Input resistance	12	15		k $\Omega$	$-7V \leq V_{CM} \leq 12V$
Input current (A, B); $V_{IN} = 12V$			1.0	mA	$DE = 0V, V_{CC} = 0V$ or $5.25V, V_{IN} = 12V$
Input current (A, B); $V_{IN} = -7V$			-0.8	mA	$DE = 0V, V_{CC} = 0V$ or $5.25V, V_{IN} = -7V$
Short circuit current	7		95	mA	$0V \leq V_O \leq V_{CC}$
<b>SP483E Receiver AC Characteristics</b>					
Maximum data rate	250			kbps	$\overline{RE} = 0V, DE = 0V$
Receiver input to output	250		2000	ns	$t_{PLH}$ ; See Figures 3 & 7, $R_{DIFF} = 54\Omega, C_{L1} = C_{L2} = 100pF$
Receiver input to output	250		2000	ns	$t_{PHL}$ ; See Figures 3 & 7, $R_{DIFF} = 54\Omega, C_{L1} = C_{L2} = 100pF$
Differential receiver skew $ t_{PHL} - t_{PLH} $		100		ns	$R_{DIFF} = 54\Omega, C_{L1} = C_{L2} = 100pF$ , See Figures 3 and 7
Receiver enable to output low		45	70	ns	$C_{RL} = 15pF$ , Figures 2 & 8; $S_1$ Closed
Receiver enable to output high		45	70	ns	$C_{RL} = 15pF$ , Figures 2 & 8; $S_2$ Closed
Receiver Disable from low		45	70	ns	$C_{RL} = 15pF$ , Figures 2 & 8; $S_1$ Closed
Receiver Disable from high		45	70	ns	$C_{RL} = 15pF$ , Figures 2 & 8; $S_2$ Closed

**Electrical Characteristics, Continued**

T<sub>AMB</sub> = T<sub>MIN</sub> to T<sub>MAX</sub> and V<sub>CC</sub> = 5V ±5% unless otherwise noted

PARAMETERS	MIN.	TYP.	MAX.	UNITS	CONDITIONS
<b>SP483E Shutdown Timing</b>					
Time to shutdown	50	200	600	ns	$\overline{RE} = 5V, DE = 0V$
Driver enable from shutdown to output high			2000	ns	C <sub>L</sub> = 100pF; See Figures 4 and 6; S <sub>2</sub> Closed
Driver enable from shutdown to output low			2000	ns	C <sub>L</sub> = 100pF; See Figures 4 and 6; S <sub>1</sub> Closed
Receiver enable from shutdown to output high		300	2500	ns	C <sub>L</sub> = 15pF; See Figures 2 and 8; S <sub>2</sub> Closed
Receiver enable from shutdown to output low		300	2500	ns	C <sub>L</sub> = 15pF; See Figures 2 and 8; S <sub>1</sub> Closed
<b>Power Requirements</b>					
Supply voltage V <sub>CC</sub>	4.75		5.25	Volts	
Supply current					
No load		900		μA	$\overline{RE}, DI = 0V$ or V <sub>CC</sub> ; DE = V <sub>CC</sub>
		600		μA	$\overline{RE} = 0V, DI = 0V$ or 5V; DE = 0V
Shutdown mode		1	10	μA	DE = 0V, $\overline{RE} = V_{CC}$
<b>Environmental and Mechanical</b>					
Operating Temperature					
Commercial (_C_)	0		70	°C	
Industrial (_E_)	-40		85	°C	
Storage Temperature	-65		150	°C	
Package					
NSOIC (_N)					

**Pin Functions**

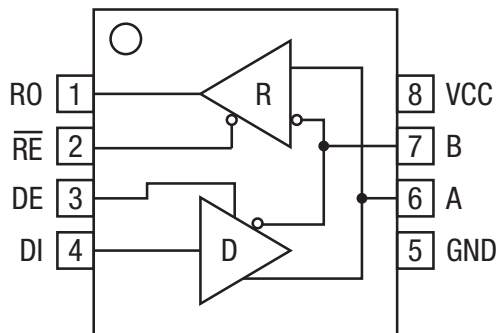

SP483E  
Pinout (Top View)

Pin Number	Pin Name	Description
1	RO	Receiver output
2	$\overline{RE}$	Receiver output enable active LOW
3	DE	Driver output enable active HIGH
4	DI	Driver input
5	GND	Ground connection
6	A	Non-inverting driver output / receiver input
7	B	Inverting driver output / receiver input
8	VCC	Positive supply 4.75V ≤ V <sub>CC</sub> ≤ 5.25V

Test Circuits

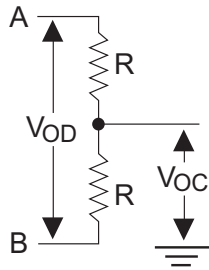

Figure 1: RS-485 Driver DC Test Load Circuit

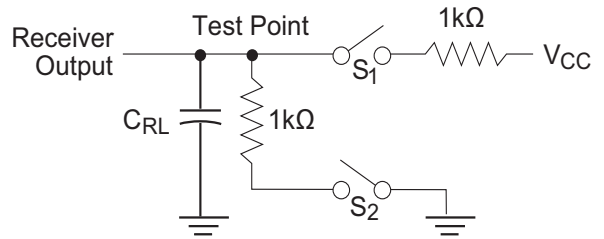

Figure 2: Receiver Timing Test Load Circuit

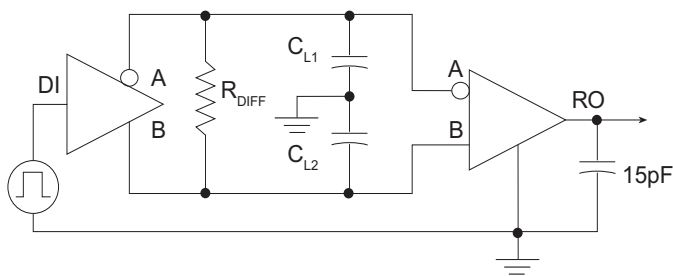

Figure 3: RS-485 Driver/Receiver Timing Test Circuit

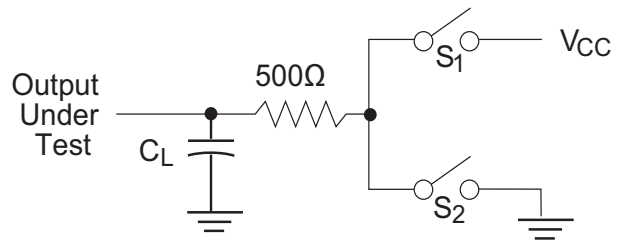

Figure 4: Driver Timing Test Load #2 Circuit

Switching Waveforms

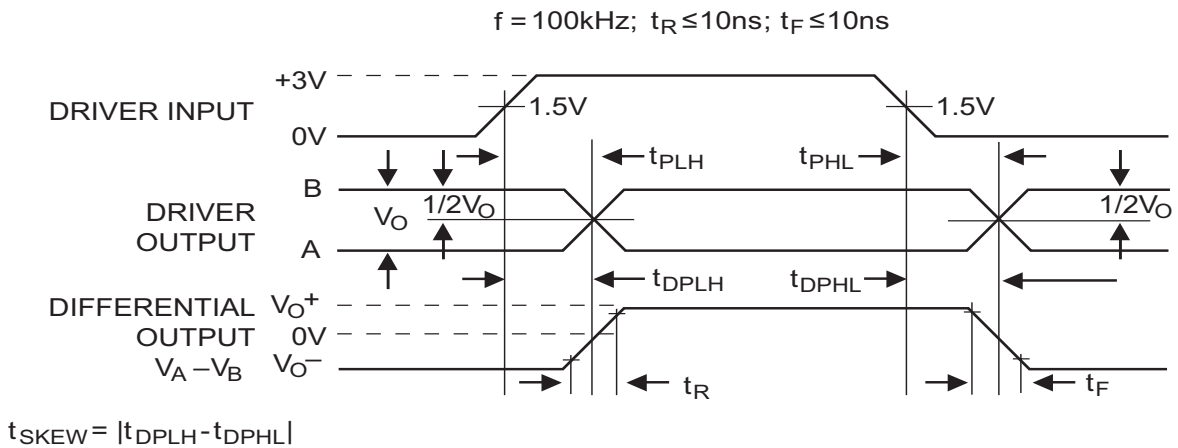

Figure 5: Driver Propagation Delays

Switching Waveforms (Continued)

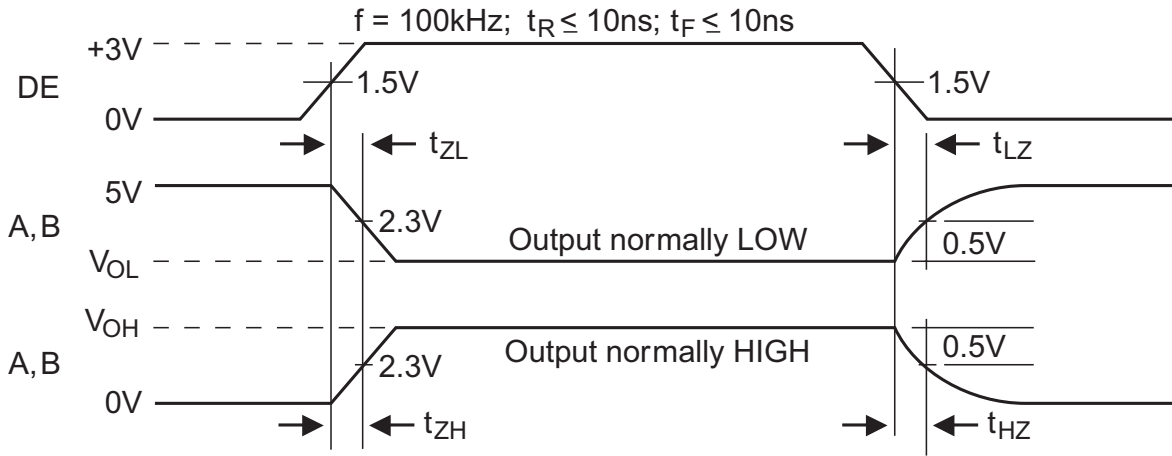
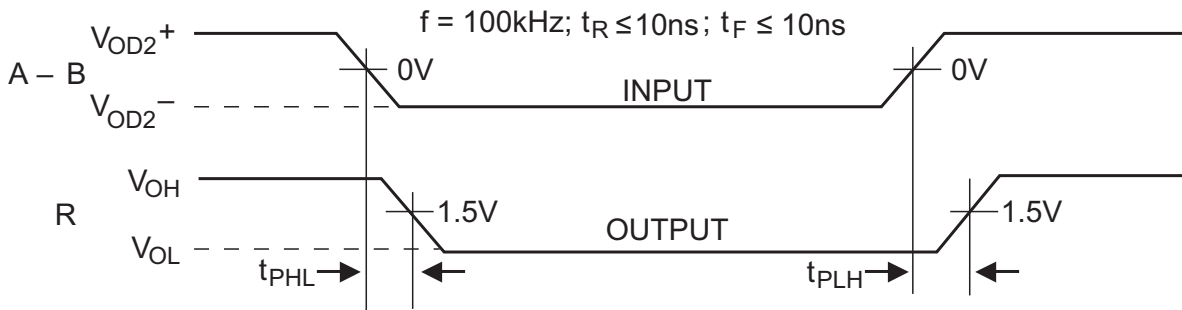

Figure 6: Driver Enable and Disable Times



$$t_{\text{SKEW}} = |t_{\text{PHL}} - t_{\text{PLH}}|$$

Figure 7: Receiver Propagation Delays

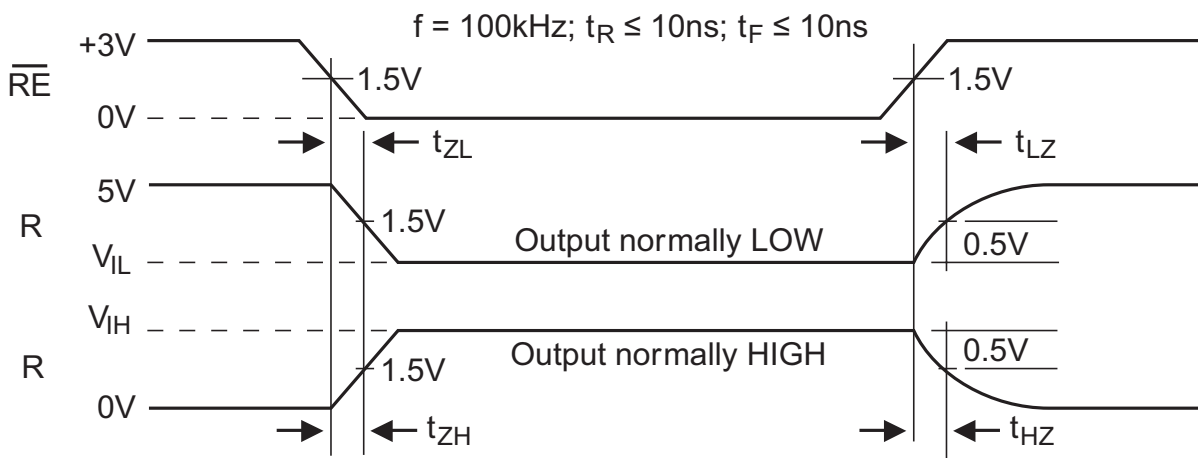

Figure 8: Receiver Enable and Disable Times

## Description

The SP483E is a half-duplex differential transceiver that meets the requirements of RS-485 and RS-422. Fabricated with a MaxLinear proprietary BiCMOS process, this product requires a fraction of the power of older bipolar designs.

The RS-485 standard is ideal for multi-drop applications and for long-distance interfaces. RS-485 allows up to 32 drivers and 32 receivers to be connected to a data bus, making it an ideal choice for multi-drop applications. Since the cabling can be as long as 4,000 feet, RS-485 transceivers are equipped with a wide (-7V to 12V) common mode range to accommodate ground potential differences. Because RS-485 is a differential interface, data is virtually immune to noise in the transmission line.

### Drivers

The driver outputs of the SP483E are differential outputs meeting the RS-485 and RS-422 standards. The typical voltage output swing with no load will be 0 Volts to 5 Volts. With worst case loading of 54 $\Omega$  across the differential outputs, the drivers can maintain greater than 1.5V voltage levels. The drivers have an enable control line which is active HIGH. A logic HIGH on DE (pin 3) will enable the differential driver outputs. A logic LOW on the DE (pin 3) will tri-state the driver outputs.

The SP483E has internally slew rate limited driver outputs to minimize EMI. The maximum data rate for the SP483E drivers is 250kbps under load.

### Receivers

The SP483E receivers have differential inputs with an input sensitivity as low as  $\pm 200\text{mV}$ . Input impedance of the receivers is typically 15k $\Omega$  (12k $\Omega$  minimum). A wide common mode range of -7V to 12V allows for large ground potential differences between systems. The receivers have a tri-state enable control pin. A logic LOW on  $\overline{\text{RE}}$  (pin 2) will enable the receiver, a logic HIGH on  $\overline{\text{RE}}$  (pin 2) will disable the receiver.

The SP483E receiver is rated for data rates up to 250kbps. The receivers are equipped with the fail-safe feature. Fail-safe guarantees that the receiver output will be in a HIGH state when the input is left unconnected.

### Shutdown Mode

The SP483E is equipped with a Shutdown mode. To enable the shutdown state, both driver and receiver must be disabled simultaneously. A logic LOW on DE (pin 3) and a Logic HIGH on  $\overline{\text{RE}}$  (pin 2) will put the SP483E into Shutdown mode. In Shutdown, supply current will drop to typically 1 $\mu\text{A}$ .

INPUTS			LINE CONDITION	OUTPUTS	
$\overline{\text{RE}}$	DE	DI		A	B
X	1	1	No Fault	1	0
X	1	0	No Fault	0	1
X	0	X	X	Z	Z
X	1	X	Fault	Z	Z

Table 1: Transmit Function Truth Table

INPUTS		A - B	OUTPUTS
$\overline{\text{RE}}$	DE		R
0	0	0.2V	1
0	0	-0.2V	0
0	0	Inputs Open	1
1	0	X	Z

Table 2: Receive Function Truth Table

**ESD Tolerance**

The SP483E incorporates ruggedized ESD cells on all driver output and receiver input pins. The ESD structure is improved over our previous family for more rugged applications and environments sensitive to electro-static discharges and associated transients. The improved ESD tolerance is at least  $\pm 15\text{kV}$  without damage or latch-up.

There are different methods of ESD testing applied:

- a) MIL-STD-883, Method 3015.7
- b) IEC61000-4-2 Air-Discharge
- c) IEC61000-4-2 Direct Contact

The Human Body Model has been the generally accepted ESD testing method for semiconductors. This method is also specified in MIL-STD-883, Method 3015.7 for ESD testing. The premise of this ESD test is to simulate the human body's potential to store electro-static energy and discharge it to an integrated circuit. The simulation is

performed by using a test model as shown in Figure 9. This method will test the IC's capability to withstand an ESD transient during normal handling such as in manufacturing areas where the IC's tend to be handled frequently. The IEC61000-4-2, formerly IEC801-2, is generally used for testing ESD on equipment and systems.

For system manufacturers, they must guarantee a certain amount of ESD protection since the system itself is exposed to the outside environment and human presence. The premise with IEC61000-4-2 is that the system is required to withstand an amount of static electricity when ESD is applied to points and surfaces of the equipment that are accessible to personnel during normal usage. The transceiver IC receives most of the ESD current when the ESD source is applied to the connector pins. The test circuit for IEC61000-4-2 is shown on Figure 10. There are two methods within IEC61000-4-2, the Air Discharge method and the Contact Discharge method.

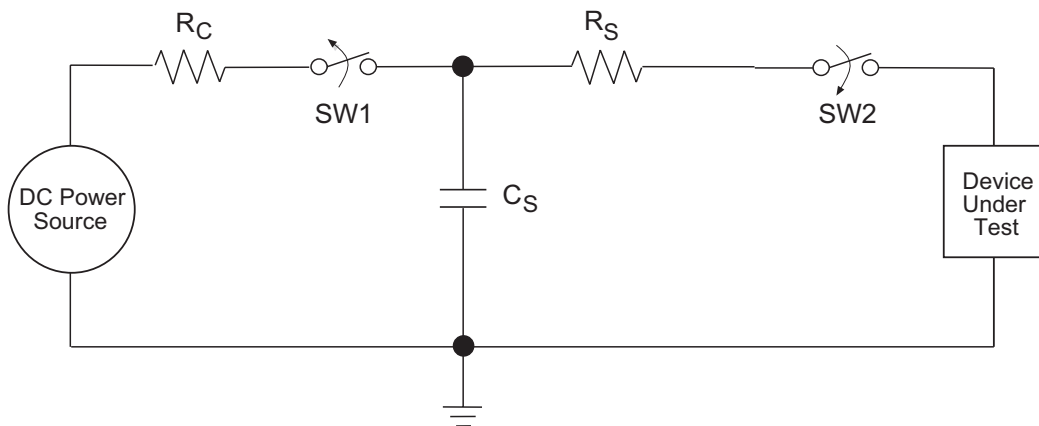

Figure 9: ESD Test Circuit for Human Body Model

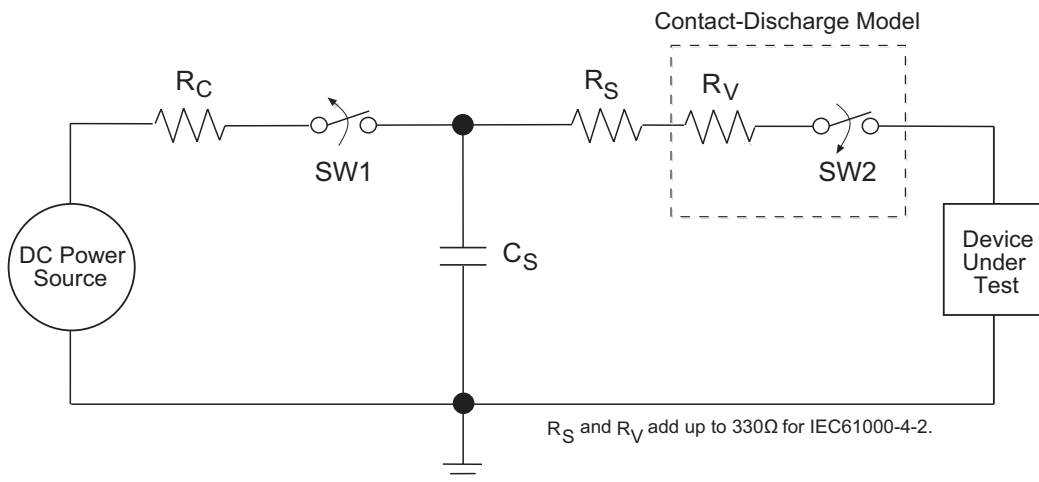

Figure 10: ESD Test Circuit for IEC61000-4-2



### ESD Tolerance (Continued)

With the Air Discharge Method, an ESD voltage is applied to the equipment under test (EUT) through air. This simulates an electrically charged person ready to connect a cable onto the rear of the system only to find an unpleasant zap just before the person touches the back panel. The high energy potential on the person discharges through an arcing path to the rear panel of the system before he or she even touches the system. This energy, whether discharged directly or through air, is predominantly a function of the discharge current rather than the discharge voltage. Variables with an air discharge such as approach speed of the object carrying the ESD potential to the system and humidity will tend to change the discharge current. For example, the rise time of the discharge current varies with the approach speed.

The Contact Discharge Method applies the ESD current directly to the EUT. This method was devised to reduce the unpredictability of the ESD arc. The discharge current rise time is constant since the energy is directly transferred without the air-gap arc. In situations such as hand held systems, the ESD charge can be directly discharged to the equipment from a person already holding the equipment. The current is transferred on to the keypad or the serial port of the equipment directly and then travels through the PCB and finally to the IC.

The circuit model in Figures 9 and 10 represent the typical ESD testing circuit used for all three methods. The CS is initially charged with the DC power supply when the first switch (SW1) is on. Now that the capacitor is charged, the second switch (SW2) is on while SW1 switches off.

The voltage stored in the capacitor is then applied through  $R_S$ , the current limiting resistor, onto the device under test (DUT). In ESD tests, the SW2 switch is pulsed so that the device under test receives a duration of voltage.

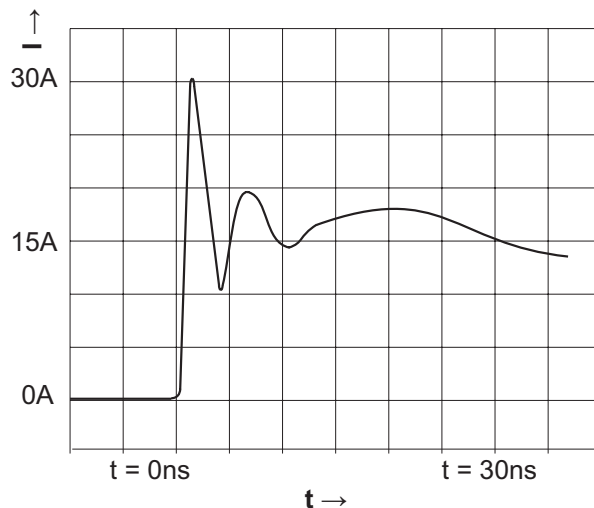

Figure 11: ESD Test Waveform for IEC61000-4-2

For the Human Body Model, the current limiting resistor ( $R_S$ ) and the source capacitor ( $C_S$ ) are  $1.5k\Omega$  and  $100pF$ , respectively. For IEC-61000-4-2, the current limiting resistor ( $R_S$ ) and the source capacitor ( $C_S$ ) are  $330\Omega$  and  $150pF$ , respectively.

The higher  $C_S$  value and lower  $R_S$  value in the IEC61000-4-2 model are more stringent than the Human Body Model. The larger storage capacitor injects a higher voltage to the test point when SW2 is switched on. The lower current limiting resistor increases the current charge onto the test point.

DEVICE PIN TESTED	HUMAN BODY MODEL	IEC61000-4-2		
		Air Discharge	Direct Contact	Level
Driver Outputs	$\pm 15kV$	$\pm 15kV$	$\pm 8kV$	4
Receiver Inputs	$\pm 15kV$	$\pm 15kV$	$\pm 8kV$	4

Table 1: Transceiver ESD Tolerance Levels

Mechanical Dimensions

NSOIC8

Top View

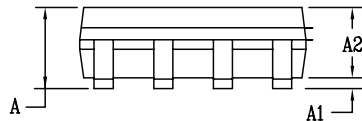
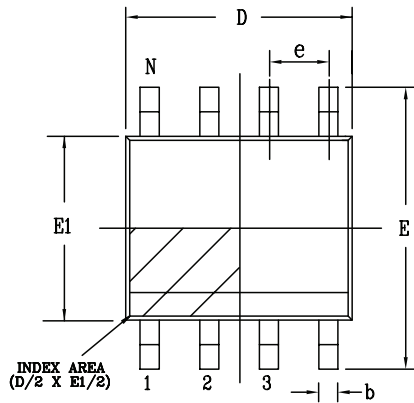

Side View

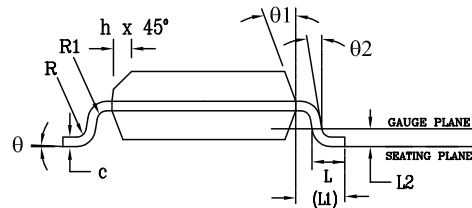

Front View

PACKAGE OUTLINE NSOIC .150" BODY JEDEC MS-012 VARIATION AA						
SYMBOLS	COMMON DIMENSIONS IN MM (Control Unit)			COMMON DIMENSIONS IN INCH (Reference Unit)		
	MIN	NOM	MAX	MIN	NOM	MAX
A	1.35	—	1.75	0.053	—	0.069
A1	0.10	—	0.25	0.004	—	0.010
A2	1.25	—	1.65	0.049	—	0.065
b	0.31	—	0.51	0.012	—	0.020
c	0.17	—	0.25	0.007	—	0.010
E	6.00 BSC			0.236 BSC		
E1	3.90 BSC			0.154 BSC		
e	1.27 BSC			0.050 BSC		
h	0.25	—	0.50	0.010	—	0.020
L	0.40	—	1.27	0.016	—	0.050
L1	1.04 REF			0.041 REF		
L2	0.25 BSC			0.010 BSC		
R	0.07	—	—	0.003	—	—
R1	0.07	—	—	0.003	—	—
q	0°	—	8°	0°	—	8°
q1	5°	—	15°	5°	—	15°
q2	0°	—	—	0°	—	—
D	4.90 BSC			0.193 BSC		
N	8					

Drawing No: POD-00000108

Revision: A

Ordering Information<sup>(1)</sup>

Part Number	Operating Temperature Range	Lead-Free	Package	Packaging Method
SP483ECN-L/TR	0°C to 70°C	Yes <sup>(2)</sup>	8-pin NSOIC	Reel
SP483EEN-L/TR	-40°C to 85°C			Reel

**NOTE:**

1. Refer to [www.exar.com/SP483E](http://www.exar.com/SP483E) for most up-to-date Ordering Information.
2. Visit [www.exar.com](http://www.exar.com) for additional information on Environmental Rating.

## Revision History

Revision	Date	Description
05	2000	Legacy Sipex Datasheet
1.0.0	02/09/12	Convert to Exar Format. Update ordering information. Change ESD specification to IEC61000-4-2.
1.0.1	2/7/18	Update to MaxLinear logo. Remove GND from Differential Output Voltage min (page 2). Update format and ordering information table. Truth Tables moved to page 7 description section. Removed obsolete PDIP from mechanicals and mechanical dimensions.



**Corporate Headquarters:**  
 5966 La Place Court  
 Suite 100  
 Carlsbad, CA 92008  
 Tel.: +1 (760) 692-0711  
 Fax: +1 (760) 444-8598  
[www.maxlinear.com](http://www.maxlinear.com)

**High Performance Analog:**  
 1060 Rincon Circle  
 San Jose, CA 95131  
 Tel.: +1 (669) 265-6100  
 Fax: +1 (669) 265-6101  
 Email: [serialtechsupport@exar.com](mailto:serialtechsupport@exar.com)  
[www.exar.com](http://www.exar.com)

The content of this document is furnished for informational use only, is subject to change without notice, and should not be construed as a commitment by MaxLinear, Inc.. MaxLinear, Inc. assumes no responsibility or liability for any errors or inaccuracies that may appear in the informational content contained in this guide. Complying with all applicable copyright laws is the responsibility of the user. Without limiting the rights under copyright, no part of this document may be reproduced into, stored in, or introduced into a retrieval system, or transmitted in any form or by any means (electronic, mechanical, photocopying, recording, or otherwise), or for any purpose, without the express written permission of MaxLinear, Inc.

MaxLinear, Inc. does not recommend the use of any of its products in life support applications where the failure or malfunction of the product can reasonably be expected to cause failure of the life support system or to significantly affect its safety or effectiveness. Products are not authorized for use in such applications unless MaxLinear, Inc. receives, in writing, assurances to its satisfaction that: (a) the risk of injury or damage has been minimized; (b) the user assumes all such risks; (c) potential liability of MaxLinear, Inc. is adequately protected under the circumstances.

MaxLinear, Inc. may have patents, patent applications, trademarks, copyrights, or other intellectual property rights covering subject matter in this document. Except as expressly provided in any written license agreement from MaxLinear, Inc., the furnishing of this document does not give you any license to these patents, trademarks, copyrights, or other intellectual property.

Company and product names may be registered trademarks or trademarks of the respective owners with which they are associated.

© 2000 - 2018 MaxLinear, Inc. All rights reserved