



PAC5524

High Pin-Count 70V Motor Controller and Driver for BLDC Motors

1 Product Overview

The PAC5524 is a Power Application Controller[®] (PAC) product that is optimized for high-pin count and high-speed BLDC motor control. The PAC5524 integrates a 150MHz Arm[®] Cortex[®]-M4F 32-bit microcontroller core with Active-Semi's proprietary and patent-pending Multi-Mode Power Manager[™], Configurable Analog Front-End[™] and Application Specific Power Drivers[™] to form the most compact microcontroller-based power and motor control solution available.

The PAC5524 microcontroller features 128kB of embedded FLASH and 32kB of SRAM memory, a 2.5MSPS analog-to-digital converter (ADC) with programmable auto-sampling of up to 24 conversion sequences, 3.3V IO, flexible clock control system, PWM and general-purpose timers and several serial communications interfaces.

The Multi-Mode Power Manager (MMPM) provides "all-in-one" efficient power management solution for multiple types of power sources. It features a configurable multi-mode switching supply controller capable of operating a buck or SEPIC converter and up to four linear regulated voltage supplies. The Application Specific Power Drivers (ASPD) are power drivers designed for half bridge, H-bridge, 3-phase, and general-purpose driving. The Configurable Analog Front End (CAFE) comprises differential programmable gain amplifiers, single-ended programmable gain amplifiers, comparators, digital-to-analog converters, and I/Os for programmable and inter-connectible signal sampling, feedback amplification, and sensor monitoring of multiple analog input signals.

The PAC5524 is packaged in an 8x8mm, 64-lead QFN package with for compact battery-powered BLDC motor applications.

2 Functional Block Diagram

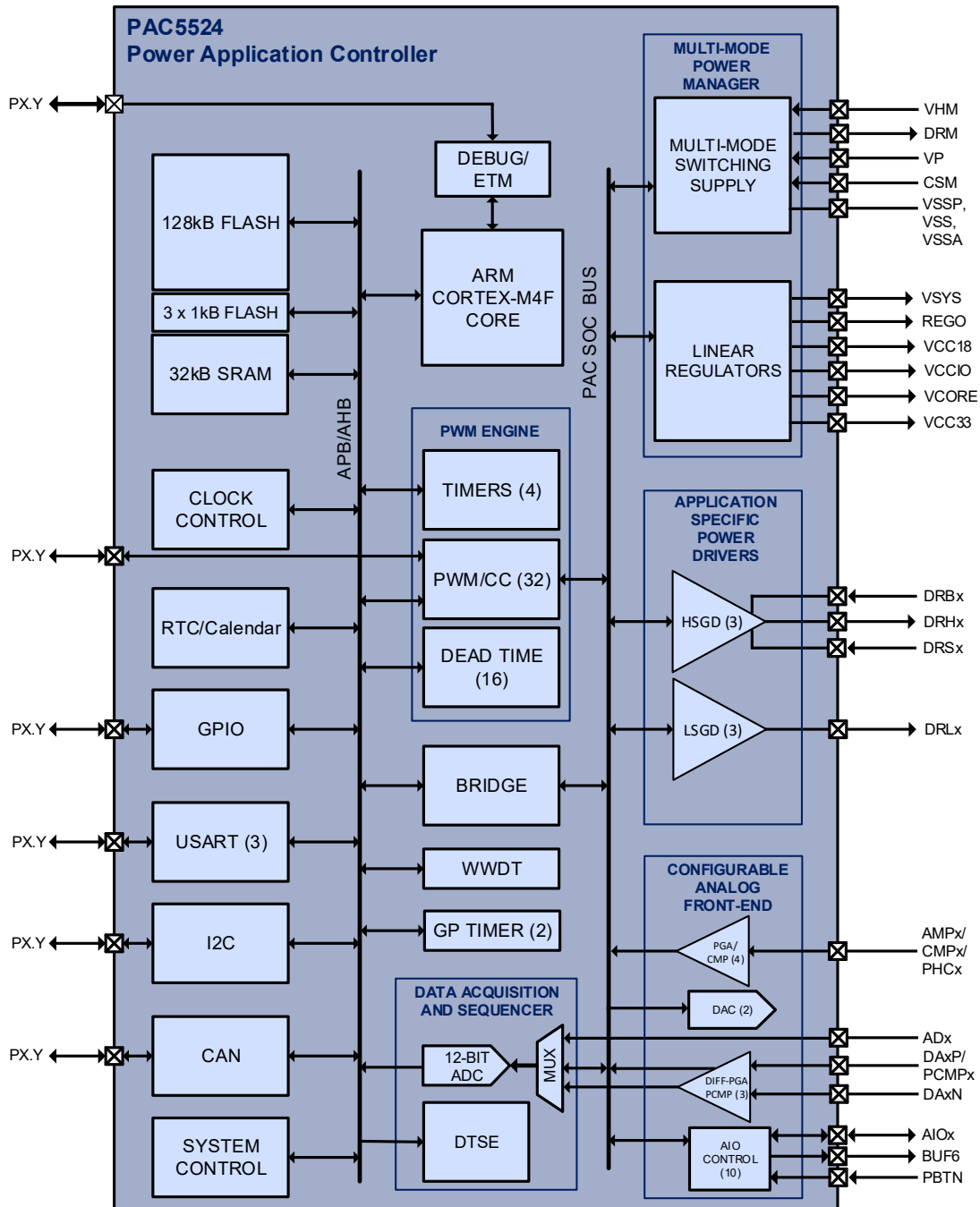

3 Key Features

Multi-Mode Power Manager™ (MMPM)

- Optional multi-mode switching supply controller configurable for DC/DC Buck or SEPIC topologies
- Direct DC supply up to 20V
- Integrated LDOs for MCU core, IO, analog with power and hibernate management
- Power and temperature monitor, warning and fault detection
- Low-power total hibernate mode, $I_Q = 18\mu A$

Configurable Analog Front-End™ (CAFE)

- 3 Differential Programmable-gain Amplifiers
- 4 Single-ended Programmable-gain Amplifiers
- 2.5V ADC reference
- Programmable over-current shutdown
- Hibernate push-button wake-up
- Power supply monitoring via ADC

Application Specific Power Drivers™ (ASPD)

- Integrated level shifters and pre-drivers
- 3 Low-side and 3 High-Side gate drivers with 1.5A gate driving capacity
- Break-before-make (BBM) hardware dead-time enforcement to prevent shoot-through
- Configurable propagation delay and fault protection
- OC, UV protection

MCU

- 150MHz Arm® Cortex®-M4F MCU
- Hardware multiplier and divider
- Single-precision Floating Point Unit (FPU)
- Nested Vectored Interrupt Controller (NVIC) with 32 interrupts and 8 priority levels
- Clock-gating for low-power operation
- Embedded Trace Macrocell (ETM) for in-system debugging in real-time without breakpoints

Memory

- 128kB FLASH, 32kB SRAM with ECC
- 2 x 1kB INFO FLASH for manufacturing information
- 1 x 1kB INFO FLASH for user parameter storage and application configuration code
- 4-level user-configurable code protection

ADC

- 12-bit 2.5MSPS SAR ADC
- Dynamic Triggering and Sequence Engine (DTSE)
 - Up to 16 configurable sequences
 - Dedicated memory for conversion results

IO

- 3.3V digital input/output or analog input for ADC
- Configurable weak pull-up or pull-down
- Configurable drive strength (6mA to 25mA minimum)
- Flexible peripheral MUX allowing each IO pin to select from up to 8 peripheral functions
- Flexible interrupt controller

Flexible Clock Control System (CCS)

- 300MHz PLL from internal 2% oscillator
- 20MHz ring oscillator
- Optional 20MHz external clock input

Timing Generators

- Four 16-bit PWM timers with up to 8 CCR output units each
- 24-bit SysTick count-down timer
- Windowed Watch-dog Timer (WWDT)
- 24-bit Real-Time Clock (RTC) with calendar and alarm
- 2 x 24-bit General-purpose count-down timers with interrupt
- Hibernate wake-up timer for sleep modes from 0.125s to 8s

Communication Peripherals

- 3 x USART (UART or SPI)
- I2C master/slave
- SPI master/slave, up to 25MHz
- CAN 2.0B Controller
- SWD or JTAG serial debug interfaces
- Embedded Trace Macrocell (ETM)

8b/16b CRC Engine

96-bit Unique ID

Physical

- $T_A = -40C$ to $125C$
- QFN 8x8mm 64-pin package
 - Exposed pad for thermal management



PAC5524

High Pin-Count 70V Motor Controller and Driver for BLDC Motors

4 Ordering Information

Part Number	Temperature Range	Package	Pins	Packaging
PAC5524QF	-40°C to 125°C	TQFN88-64L	64 + Exposed Pad	Tray (2600 piece)
PAC5524QF-T				Tape and Reel (3000 piece)



PAC5524

High Pin-Count 70V Motor Controller and Driver for BLDC Motors

Table of Contents

1	Product Overview	1
2	Functional Block Diagram	2
3	Key Features	3
4	Ordering Information	4
5	Absolute Maximum Ratings	10
6	Multi-Mode Power Manager (MMPM)	11
6.1	Features	11
6.2	System Block Diagram	11
6.3	Functional Description	12
6.3.1	Multi-Mode Switching Supply (MMSS) Controller	12
6.3.2	Linear Regulators	13
6.3.3	Power-up Sequence	14
6.3.4	Hibernate Mode	16
6.3.5	Power and Temperature Monitor	16
6.3.6	Voltage Reference	16
6.4	Electrical Characteristics	17
6.4.1	MMSS Electrical Characteristics	17
6.4.2	Linear Regulators Electrical Characteristics	18
6.4.3	Power Monitor Electrical Characteristics	19
6.5	Typical Performance Characteristics	20
7	Configurable Analog Front-End (CAFE)	21
7.1	Features	21
7.2	System Block Diagram	22
7.3	Functional Description	23
7.3.1	Differential Programmable Gain Amplifier (DA)	23
7.3.2	Single-Ended Programmable Gain Amplifier (AMP)	23
7.3.3	General-Purpose Comparator (CMP)	23
7.3.4	Phase Comparator (PHC)	23
7.3.5	Protection Comparator (PCMP)	24
7.3.6	Analog Output Buffer (BUF)	24
7.3.7	Analog Front End I/O (AIO)	24
7.3.8	Push Button (PBTN)	24
7.3.9	HP DAC and LP DAC	24



PAC5524

High Pin-Count 70V Motor Controller and Driver for BLDC Motors

7.3.10	ADC Analog Input	25
7.3.11	Configurable Analog Signal Matrix (CASM)	26
7.3.12	Configurable Digital Signal Matrix (CDSM)	26
7.3.13	Temperature Protection	26
7.4	Electrical Characteristics	27
7.4.1	Differential Programmable Gain Amplifier (DA)	27
7.4.2	Single-Ended Programmable Gain Amplifier (SA)	28
7.4.3	General Purpose Comparator (CMP)	28
7.4.4	Phase Comparator (PHC)	29
7.4.5	Protection Comparator (PCMP)	29
7.4.6	Analog Output Buffer (BUF)	29
7.4.7	Analog Front End (AIO) Electrical Characteristics	30
7.4.8	Push-Button (PBTN) Electrical Characteristics	30
7.4.9	HP DAC and LP DAC Electrical Characteristics	30
7.4.10	Temperature Protection Electrical Characteristics	31
7.5	Typical Performance Characteristics	32
8	Application Specific Power Drivers (ASPD)	33
8.1	Features	33
8.2	System Block Diagram	33
8.3	Functional Description	34
8.4	Low-Side Gate Drivers	34
8.5	High-Side Gate Drivers	34
8.6	High-Side Switching Transients	35
8.7	Power Drivers Control	35
8.8	Gate Driver Fault Protection	36
8.9	Electrical Characteristics	37
8.9.1	Low-Side Gate Drivers	37
8.9.2	High-Side Gate Drivers	37
8.9.3	High-Side and Low-Side Gate Driver Propagation Delay	38
8.10	Typical Performance Characteristics	39
9	SOC Control Signals	41
9.1	High-side and Low-Side Gate Drivers	41
9.2	SPI SOC Bus	44
9.3	ADC EMUX	44



PAC5524

High Pin-Count 70V Motor Controller and Driver for BLDC Motors

9.4	Analog Interrupts	44
10	ADC/DTSE	45
10.1	Features	45
10.2	System Block Diagram	45
10.3	Functional Description	46
10.3.1	ADC	46
10.3.2	Dynamic Triggering and Sample Engine (DTSE)	46
10.3.3	EMUX Control	46
10.4	Electrical Characteristics	47
11	Memory System	48
11.1	Features	48
11.2	System Block Diagram	48
11.3	Functional Description	49
11.3.1	Program FLASH	49
11.3.2	INFO FLASH	49
11.3.3	SRAM	49
11.3.4	Code Protection	50
11.4	Electrical Characteristics	51
12	System and Clock Control (SCC)	52
12.1	Features	52
12.2	System Block Diagram	52
12.3	Functional Description	53
12.4	Clock Sources	53
12.4.1	Ring Oscillator	53
12.4.2	Reference Clock	53
12.4.3	External Clock Input	53
12.5	PLL	53
12.6	Clock Tree	53
12.6.1	FRCLK	53
12.6.2	SCLK	53
12.6.3	PCLK	54
12.6.4	ACLK	54
12.6.5	HCLK	54
12.7	Electrical Characteristics	55



PAC5524

High Pin-Count 70V Motor Controller and Driver for BLDC Motors

13	Arm® Cortex®-M4F MCU Core	56
13.1	Features	56
13.2	System Block Diagram	56
13.3	Functional Description	57
13.4	Application Typical Current Consumption	58
13.5	Electrical Characteristics	60
14	IO Controller	61
14.1	Features	61
14.2	System Block Diagram	61
14.3	Functional Description	62
14.3.1	IO Controller	62
14.3.2	GPIO Current Injection	62
14.3.3	Peripheral MUX	63
14.4	Electrical Characteristics	64
15	Serial Interface	65
15.1	Features	65
15.2	System Block Diagram	65
15.3	Functional Description	66
15.4	I ² C Controller	66
15.5	USART	66
15.5.1	USART SPI Mode	66
15.5.2	USART UART Mode	66
15.6	CAN	67
15.7	Dynamic Characteristics	68
15.7.1	Serial Interface	68
15.7.2	I ² C Dynamic Characteristics	69
15.7.3	I ² C Timing Diagram	70
16	PWM Timers	71
16.1	Features	71
16.2	System Block Diagram	73
16.3	Functional Description	74
17	General Purpose Timers	75
17.1	Features	75
17.2	System Block Diagram	75



PAC5524

High Pin-Count 70V Motor Controller and Driver for BLDC Motors

17.3	Functional Description	76
17.3.1	SOC Bus Watchdog Timer	76
17.3.2	Wake-up Timer	76
17.3.3	Real-time Clock with Calendar (RTC)	76
17.3.4	Windowed Watchdog Timer (WWDT)	76
17.3.5	GP Timer (GPT)	76
18	CRC	77
18.1	Features	77
18.2	System Block Diagram	77
18.3	Functional Description	77
19	Application Block Diagram	78
20	Thermal Characteristics	80
21	Pin Configuration and Description	81
21.1	MMPM and System Pin Descriptions	82
21.2	CAFE Pin Descriptions	83
21.3	ASPD Pin Descriptions	84
21.4	I/O Ports Pin Descriptions	85
22	Mechanical Information	86
23	Handling Precautions	87
24	Solderability	87
25	Contact Information	88
26	Important Notice	88



PAC5524

High Pin-Count 70V Motor Controller and Driver for BLDC Motors

5 Absolute Maximum Ratings

Symbol	Parameter	Value	Unit
Power Manager			
VHM, DRM to VSS	Supply Input and DC/DC Gate Drive Voltage	-0.3 to 72	V
VP to VSS	Gate Drive Voltage	-0.3 to 20	V
CSM, REGO to VSS	DC/DC current sense and VSYS regulator output	-0.3 to VP + 0.3	V
VSYS, VCCIO, AIO6 to VSS		-0.3 to 6	V
VCC33 to VSS	Analog Supply Voltage	-0.3 to 4.1	V
VCC18 to VSS	MCU FLASH Supply Voltage	-0.3 to 2.5	V
VCORE to VSS	MCU Core Supply Voltage	-0.3 to 1.44	V
Signal Manager			
AIO[0..5, 7..9] to VSS	AIO Input Voltage	-0.3 to VSYS + 0.3	V
AIO6 to VSS	AIO6 Input Voltage	-0.3 to 6	V
Driver Manager			
DRLx to VSS	Low-side Gate Drive Voltage	-0.3 to VP + 0.3	V
DRBx to VSS	Boot-strap Gate Drive Voltage	-0.3 to 84	V
DRSx to VSS	High-side Gate Drive Voltage	-6 to 72	V
dVDRSx/dt	DRSx allowable offset slew rate	5	V/ns
DRBx, DRHx to respective DRSx	Floating gate drive offset	-0.3 to 20	V
VSS, VSYS, DRLx, DRHx, VSYSW RMS current		0.2	ARMS
VSS RMS current		0.4	ARMS
VP RMS current		0.6	ARMS
IO			
PCx, PDx, PEx, PFx, PGx to VSS	MCU IO Pin Voltage	-0.3 to 4.6	V
IPCx, IPDx, IPEx, IPFx, IPGx	Pin injection current	25	mA
$\sum I_{PCx}, \sum I_{PDx}, \sum I_{PEx}, \sum I_{PFx}, \sum I_{PGx}$	Sum of all pin injection current	50	mA
Temperature			
T _A	Ambient Temperature	-40 to 125	°C
T _{STG}	Storage Temperature	-55 to 150	°C
Electro-static Discharge (ESD)			
Human Body Model (HBM)	All pins	2	kV
Charge Device Model (CDM)	All pins	1	kV

Operation of this device outside the parameter ranges given above may cause permanent damage.

6 Multi-Mode Power Manager (MPPM)

6.1 Features

- Multi-mode switching supply controller configurable as Buck or SEPIC
- DC supply up to 70V input
- Direct DC input of up to 20V with no DC/DC
- 5 linear regulators with power and hibernate management, including VREF for ADC
- Power and temperature monitor, warning, and fault detection
- Very low-power total hibernate mode

6.2 System Block Diagram

Figure 1 MPPM System Block Diagram

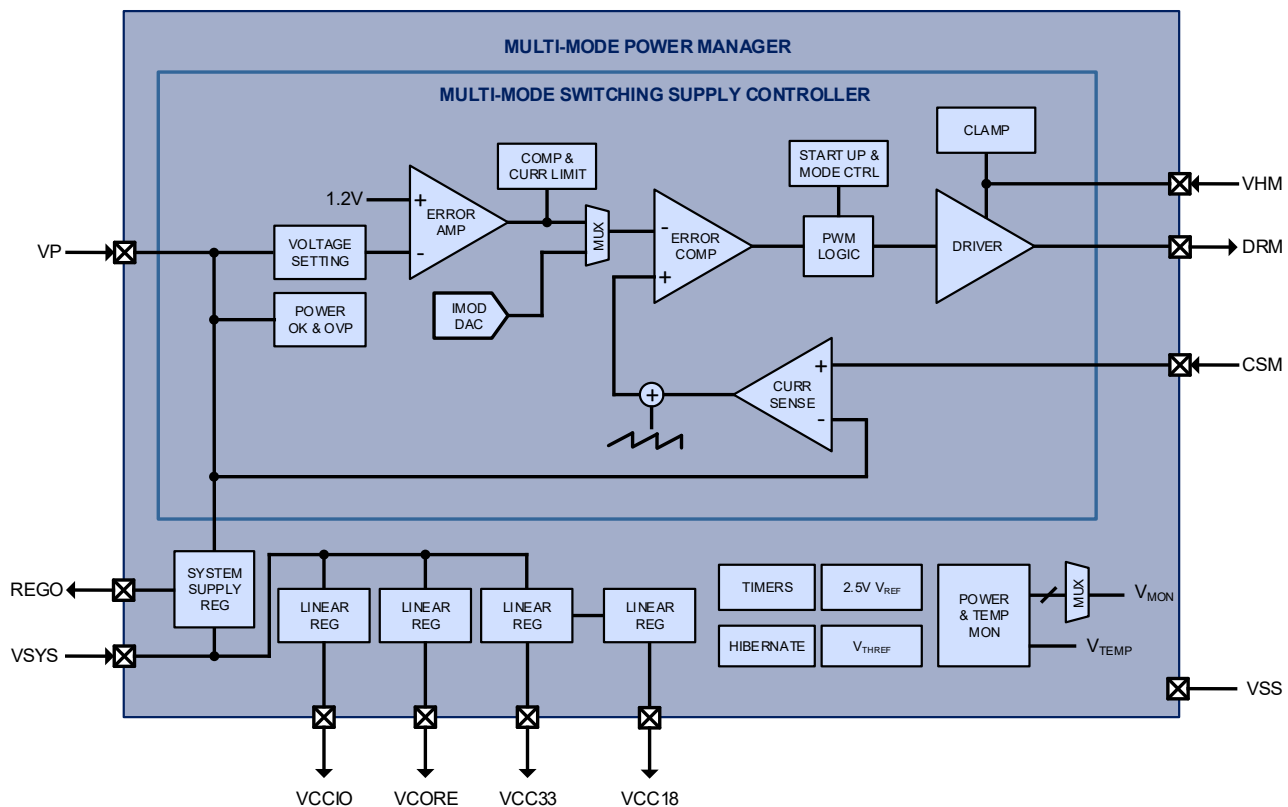

6.3 Functional Description

The Multi-Mode Power Manager is optimized to efficiently provide “all-in-one” power management required by the PAC and associated application circuitry. It incorporates a dedicated multi-mode switching supply (MMSS) controller operable as a Buck or SEPIC converter to efficiently convert power from a DC input source to generate a main supply output VP. Five linear regulators provide VCC18, VSYS, VCCIO, VCC33, and VCORE supplies for MCU FLASH, 5V system, 3.3V I/O, 3.3V mixed signal, and 1.2V microcontroller core circuitry. The power manager also handles system functions including internal reference generation, timers, hibernate mode management, and power and temperature monitoring.

6.3.1 Multi-Mode Switching Supply (MMSS) Controller

The MMSS controller drives an external power transistor for pulse-width modulation switching of an inductor or transformer for power conversion. The DRM output drives the gate of the N-CH MOSFET between the VHM on state and VSSP off state at proper duty cycle and switching frequency to ensure that the main supply voltage VP is regulated. The VP regulation voltage is initially set to 15V during start up and can be reconfigured to be 9V or 12V by the microcontroller after initialization. When VP is lower than the target regulation voltage, the internal feedback control circuitry causes the inductor current to increase to raise VP. Conversely, when VP is higher than the regulation voltage, the feedback loop control causes the inductor current to decrease to lower VP. The feedback loop is internally stabilized. The output current capability of the switching supply is determined by the external current sense resistor. In the high-side current sense buck or SEPIC mode, the inductor current signal is sensed differentially between the CSM pin and VP and has a peak current limit threshold of 0.26V.

The MMSS controller is flexible and configurable as a buck or SEPIC converter. Input sources include battery supply for buck mode or SEPIC mode as shown below. The MMSS controller operational mode is determined by external configuration and register settings from the microcontroller after power up. It can operate in either high-side or low-side current sense mode and does not require external feedback loop compensation circuitry.

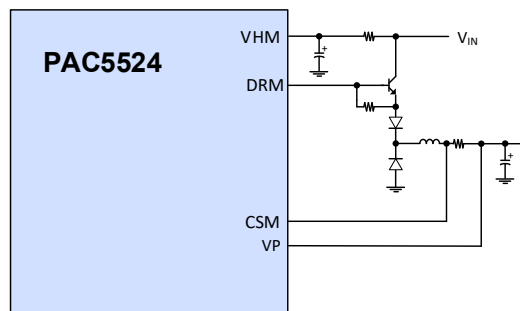

Figure 2 Buck Mode

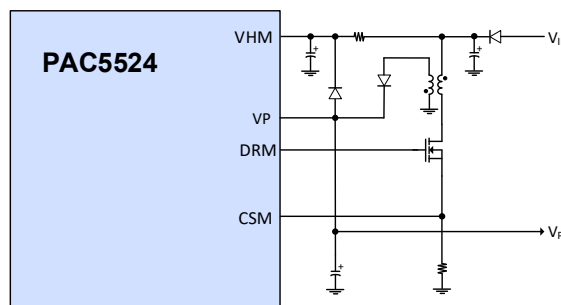

Figure 3 SEPIC Mode

High Pin-Count 70V Motor Controller and Driver for BLDC Motors

The MMSS detects and selects between high-side and low-side mode during start up based on the placement of the current sense resistor and the CSM pin voltage. It employs a safe start up mode with a 9.5kHz switching frequency until VP exceeds 4.3V under-voltage-lockout threshold, then transitions to the 45kHz default switching frequency for at least 6ms to bring VP close to the target voltage, before enabling the linear regulators. Any extra load should only be applied after the supplies are available and the microprocessor has initialized. The switching frequency can be reconfigured by the microprocessor to be 181kHz to 500kHz in the high switching frequency mode for battery-based applications, and to be 45kHz to 125kHz in the low switching frequency mode. Upon initialization, the microcontroller must reconfigure the MMSS to the desired settings for VP regulation voltage, switching mode, switching frequency, and VHM clamp. Refer to the PAC application notes and user guide for MMSS controller design and programming.

If a stable external 5V to 20V power source is available, it can power the VP main supply and all the linear regulators directly without requiring the MMSS controller to operate. In such applications, VHM can be connected directly to VP and the microcontroller should disable the MMSS upon initialization to reduce power loss.

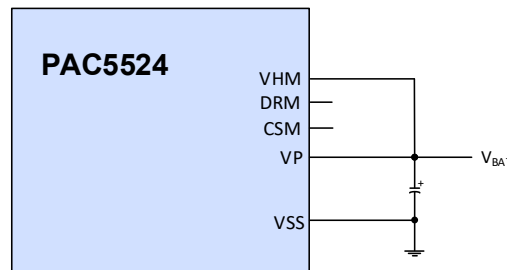

Figure 4 Direct Battery Supply

6.3.2 Linear Regulators

The MMPM includes four linear regulators. The system supply regulator (VSYS) is a medium voltage regulator that takes the VP supply and sources up to 200mA at REGO until VSYS, externally coupled to REGO, reaches 5V. This allows a properly rated external resistor to be connected from REGO to VSYS to close the loop and offload power dissipation between VP and VSYS.

Once VSYS is above 4V, the four additional linear regulators for VCC18, VCCIO, VCC33, and VCORE supplies sequentially power up. Figure 10 5 shows typical circuit connections for the linear regulators. The VCC18 regulator generates a dedicated 1.8V supply for FLASH on the MCU. The VCCIO regulator generates a dedicated 3.3V supply for IO. The VCC33 and VCORE regulators generate 3.3V and 1.2V, respectively. When VSYS, VCCIO, VCC33, and VCORE are all above their respective power good thresholds, and the configurable power on reset duration has expired, the microcontroller is initialized.

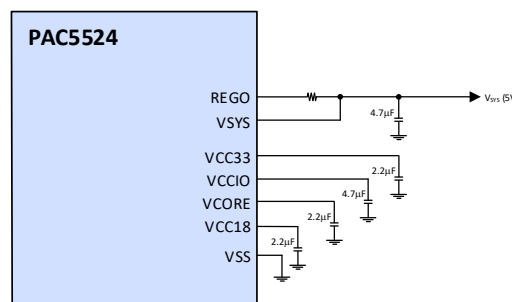

Figure 5 Linear Regulators Connections

High Pin-Count 70V Motor Controller and Driver for BLDC Motors

6.3.3 Power-up Sequence

The MMPM follows a typical power up sequence with a DC/DC as shown below.

A typical sequence begins with input power supply being applied, followed by the safe start up and start up durations to bring the switching supply output VP to 15V, before the linear regulators are enabled. When all the supplies are ready, the internal clocks become available, and the microcontroller starts executing from the program memory. During initialization, the microcontroller can reconfigure the switching supply to a different VP regulation voltage such as 9V or 12V and to an appropriate switching frequency and switching mode. The total loading on the switching supply must be kept below 25% of the maximum output current until after the reconfiguration of the switching supply is complete.

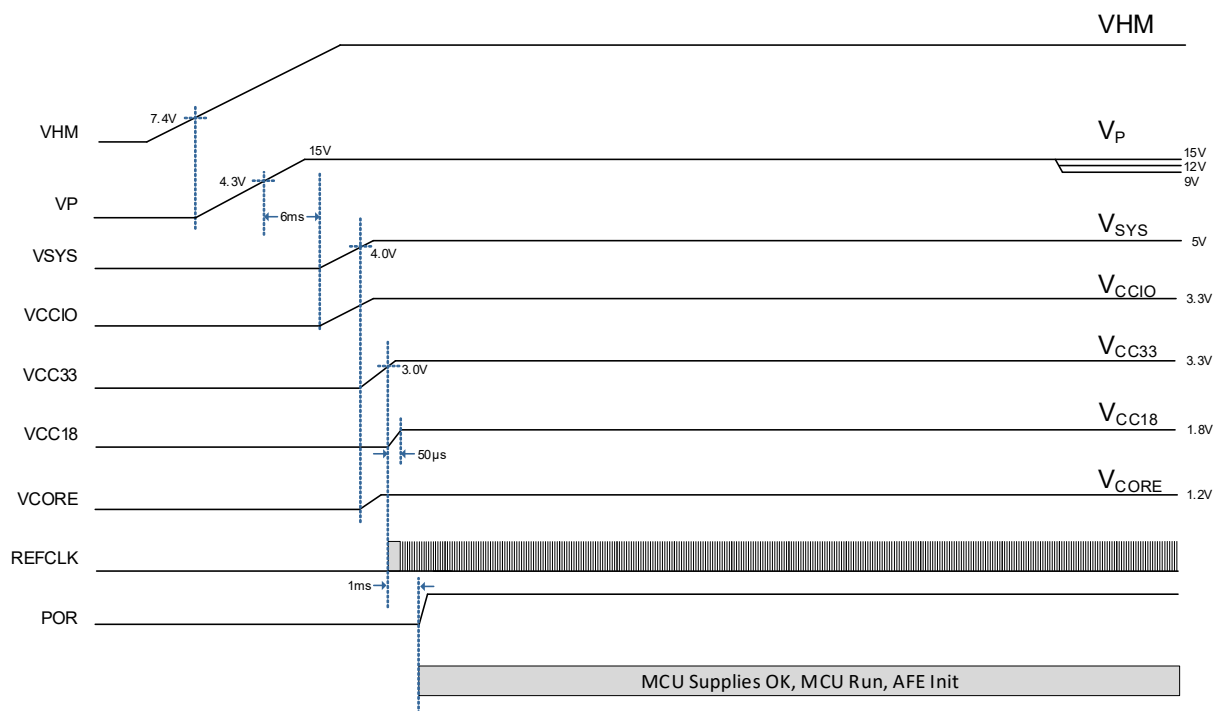

Figure 6 Power-up Sequence with DC/DC

High Pin-Count 70V Motor Controller and Driver for BLDC Motors

If the PAC5524 is used without a DC/DC by directly supplying the IC and connecting the VP and VHM supply pins on the device, the power supply start-up sequence is slightly different. This case is shown below.

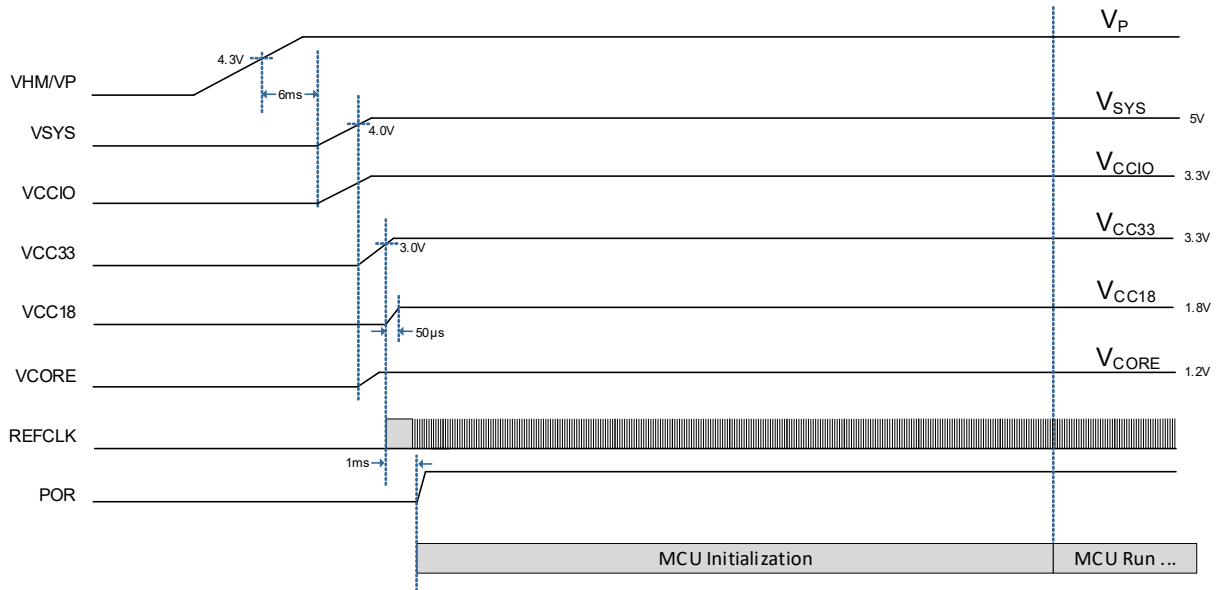

Figure 7 Power-up Sequence with direct DC supply

6.3.4 Hibernate Mode

The IC can go into an ultra-low power hibernate mode via the microcontroller firmware or via the optional push button (PBTN). In hibernate mode, only a minimal amount (typically 18 μ A) of current is used by V_P , and the MMSS controller and all internal regulators are shut down to eliminate power drain from the output supplies. The system exits hibernate mode after a wake-up timer duration (configurable from 125ms to 8s or infinite) has expired or, if push button enabled, after an additional push button event has been detected. When exiting the hibernate mode, the power manager goes through the start up cycle and the microcontroller is reinitialized. Only the persistent power manager status bits (resets and faults) are retained during hibernation.

6.3.5 Power and Temperature Monitor

Whenever any of the V_{SYS} , V_{CCIO} , V_{CC33} , or V_{CORE} power supplies falls below their respective power good threshold voltage, a fault event is detected and the microcontroller is reset. The microcontroller stays in the reset state until V_{SYS} , V_{CCIO} , V_{CC33} , and V_{CORE} supply rails are all good again and the reset time has expired. A microcontroller reset can also be initiated by a maskable temperature fault event that occurs when the IC temperature reaches 170°C. The fault status bits are persistent during reset, and can be read by the microcontroller upon re-initialization to determine the cause of previous reset.

A power monitoring signal V_{MON} is provided onto the ADC pre-multiplexer for monitoring various internal power supplies. V_{MON} can be set to be V_{CORE} , $0.4 \cdot V_{CC33}$, $0.4 \cdot V_{CCIO}$, $0.4 \cdot V_{SYS}$, $0.1 \cdot V_{REGO}$, $0.1 \cdot V_P$, or the internal compensation voltage V_{COMP} for switching supply power monitoring.

For power and temperature warning, an IC temperature warning event at 140°C are provided as a maskable interrupt to the microcontroller. This warning allows the microcontroller to safely power down the system.

In addition to the temperature warning interrupt and fault reset, a temperature monitor signal $V_{TEMP} = 1.5 + 5.04e-3 \cdot (T - 25^\circ C)$ (V) is provided onto the ADC pre-multiplexer for IC temperature measurement.

6.3.6 Voltage Reference

The reference block includes a 2.5V high precision reference voltage that provides the 2.5V reference voltage for the ADC, the DACs, and the 4-level programmable threshold voltage V_{THREF} (0.1V, 0.2V, 0.5V, and 1.25V).

High Pin-Count 70V Motor Controller and Driver for BLDC Motors

6.4 Electrical Characteristics

The Electrical Characteristics for the MMPM are shown below.

6.4.1 MMSS Electrical Characteristics

Table 1 HVCP Manager Electrical Characteristics

Symbol	Parameter	Conditions	Min.	Typ.	Max.	Units
Input Supply (VM)						
I _{HIB;VHM}	VHM hibernate mode supply current	Hibernate mode active		18	36	μA
I _{SU;VHM}	VHM start-up supply current	VHM < V _{UVLOR;VHM}		75	120	μA
I _{OP;VHM}	VHM operating supply current	DRM floating		0.3	0.5	mA
V _{OP;VHM}	VHM operating voltage range		5		70	V
V _{UVLOR;VHM}	VHM under-voltage lockout rising	VHM rising	6.8	7.4	8	V
V _{UVLOF;VHM}	VHM under-voltage lockout falling	VHM falling	6	6.6	7	V
V _{CLAMP;VHM}	VHM clamp voltage	Clamp enabled, sink current = 100 μA	14.5	16.9	19.5	V
I _{CLAMP;VHM}	VHM clamp sink current limit	Clamp enabled		4		mA
Output Supply and Feedback (VP)						
V _{REG;VP}	VP output regulation voltage	Programmable to 9V, 12V, 15V; Load = 0 to 500mA	-7	-1	5	%
K _{POK;VP}	VP power OK threshold	VP rising, hysteresis = 10%	82	87	92	%
K _{OVP;VP}	VP over-voltage protection threshold	VP rising, hysteresis = 15%; MMPM controller enabled		136		%
Switching Control						
f _{SWM;DRM}	Switching frequency programmable range	High-frequency mode, 8 settings	181		500	kHz
		Low-frequency mode, 8 settings	45		125	kHz
f _{SSU;DRM}	Safe start-up switching frequency			9.5		kHz
t _{ONMIN;DRM}	DRM Minimum on-time			440		ns
t _{OFFMIN;DRM}	DRM Minimum off-time	Low duty-cycle and low-frequency mode		25		%
		Low duty-cycle and high-frequency mode		440		ns
		High duty-cycle mode		820		ns
Current Sense (CSM pin)						
V _{DET;CSM}	CSM mode detection threshold	Rising, hysteresis = 50mV	0.40	0.55	0.69	V
V _{HSLIM;CSM}	High-side current limit threshold	181kHz, duty = 50%, relative to VP	0.17	0.26	0.35	V
V _{LSLIM;CSM}	Low-side current limit threshold	45kHz, duty = 25%	0.7	1	1.48	V
t _{BLANK;CSM}	Current sense blanking time			200		ns
V _{PROT;CSM}	Low-side abnormal current sense protection threshold	VP < 4.3V		0.8		V
		VP > 4.3V		1.9		V
Gate Driver Output (DRM pin)						
V _{OH;DRM}	High-level output voltage	5% I _{OH} , relative to VHM		VHM-1		V



PAC5524

High Pin-Count 70V Motor Controller and Driver for BLDC Motors

$V_{OL,DRM}$	Low-level output voltage	5% I_{OL}	0.6	V
$I_{OH,DRM}$	High-level output source current	$V_{DRM} = V_{HM} - 5V$	-0.3	A
$I_{OL,DRM}$	Low-level output sink current	$V_{DRM} = 5V$	0.5	A
$t_{PD,DRM}$	Strong pull-down pulse width	High-side current sense mode	240	ns

$V_{HM} = 24V$ and $T_A = -40^{\circ}C$ to $125^{\circ}C$ unless otherwise specified

6.4.2 Linear Regulators Electrical Characteristics

Table 2 Linear Regulators Electrical Characteristics

Symbol	Parameter	Conditions	Min.	Typ.	Max.	Units
$V_{OP,VP}$	VP operating voltage range		4.5		20	V
$V_{UVLO,VP}$	VP under-voltage lockout threshold	VP rising, hysteresis = 0.2V	4	4.3	4.6	V
$I_{Q,VP}$	VP quiescent supply current	MMPM only, including $I_{Q,VSYS}$		400	750	μA
$I_{Q,VSYS}$	VSYS quiescent supply current	VCCIO, VCC33, VCORE regulators only		350	600	μA
V_{SYS}	VSYS output voltage	Load = 10 μA to 200mA	4.8	5.0	5.18	V
V_{CCIO}	VCCIO output voltage	Load = 10mA	3.15	3.3	3.4	V
V_{CC33}	VCC33 output voltage	Load = 10mA	3.15	3.3	3.4	V
V_{CORE}	VCORE output voltage	Load = 10mA	1.14	1.2	1.26	V
$I_{LIM,VSYS}$	VSYS regulator current limit		220	330		mA
$I_{LIM,VCCIO}$	VCCIO regulator current limit		45	80		mA
$I_{LIM,VCC33}$	VCC33 regulator current limit		45	80		mA
$I_{LIM,VCORE}$	VCORE regulator current limit		45	80		mA
K_{SCFB}	Short-circuit fold-back			50		%
$V_{DO,VSYS}$	VSYS drop-out voltage	VP = 5V, $I_{VSYS} = 100mA$		350	680	mV
$V_{UVLO,VSYS}$	VSYS UVLO threshold	VSYS rising, hysteresis = 0.2V	3.5	4	4.4	V
$K_{POK,VCCIO}$	VCCIO power OK threshold	VCCIO rising, hysteresis = 10%	79	85	91	%
$K_{POK,VCC33}$	VCC33 power OK threshold	VCC33 rising, hysteresis = 10%	79	85	91	%
$K_{POK,VCORE}$	VCORE power OK threshold	VCORE rising, hysteresis = 10%	79	85	91	%
$t_{POK,VCC18}$	VCC18 power OK time	$C_{VCC18} = 1\mu F$			50	μS

$V_{HM} = 12V$ and $T_A = -40^{\circ}C$ to $125^{\circ}C$ unless otherwise specified

High Pin-Count 70V Motor Controller and Driver for BLDC Motors

6.4.3 Power Monitor Electrical Characteristics

Table 3 Power Monitor Electrical Characteristics

Symbol	Parameter	Conditions	Min.	Typ.	Max.	Units
V _{REF}	Reference Voltage	T _A = 25°C	2.487	2.5	2.513	V
		T _A = -40°C to 125°C	2.463	2.5	2.537	V
K _{MON}	Power Monitoring Voltage coefficient	V _{CORE}		1		V / V
		V _{SYS} , V _{CCIO} , V _{CC33}		0.4		V / V
		V _P , V _{REGO}		0.1		V / V
V _{TEMP}	Temperature monitor voltage	T _A = 25C, at ADC	1.475	1.5	1.54	V
K _{TEMP}	Temperature monitoring coefficient	At ADC		5.04		mV/K

V_{HM} = 12V and T_A = -40°C to 125°C unless otherwise specified

High Pin-Count 70V Motor Controller and Driver for BLDC Motors

6.5 Typical Performance Characteristics

VHM = 12V and $T_A = -40^{\circ}\text{C}$ to 125°C unless otherwise specified

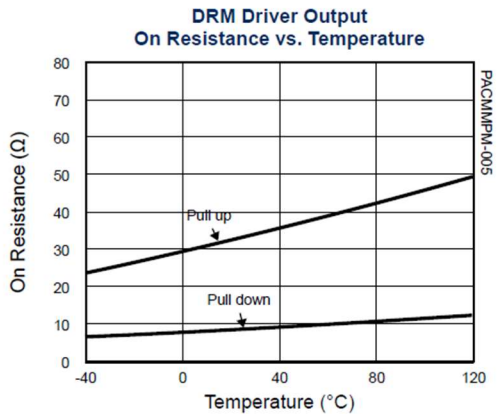
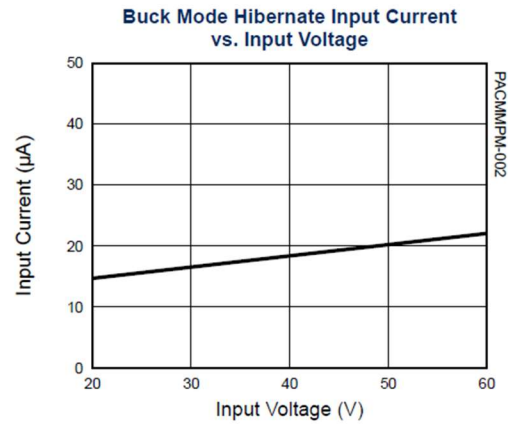
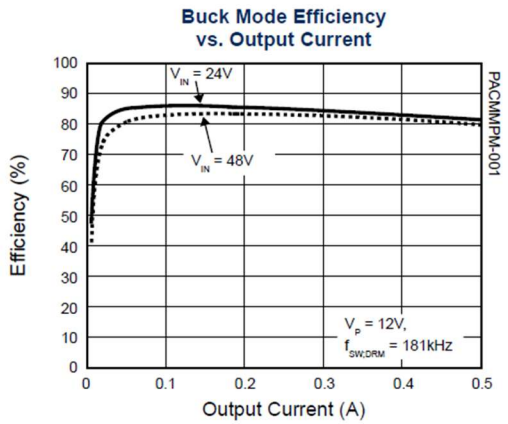



PAC5524

High Pin-Count 70V Motor Controller and Driver for BLDC Motors

7 Configurable Analog Front-End (CAFE)

7.1 Features

- 3 Differential Programmable-Gain Amplifiers (DA)
- 4 Single-Ended Programmable-Gain Amplifiers (SA)
- 10 5V IO pins
- Over-Current Protection and Shutdown Comparators
- Power Monitoring
- Hibernate Push-Button Wake-up

7.2 System Block Diagram

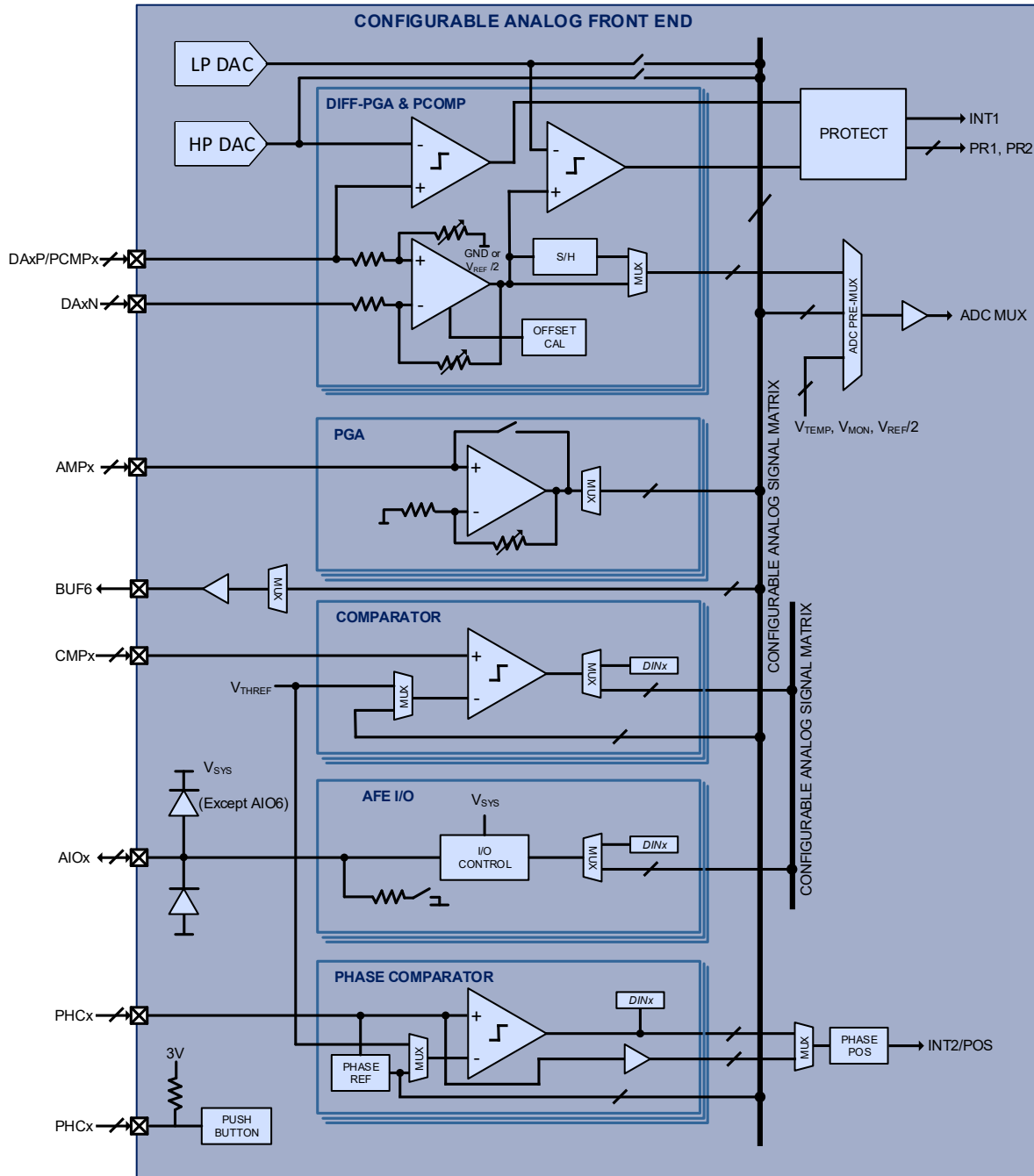

Figure 8 CAFE System Block Diagram

7.3 Functional Description

The device includes a Configurable Analog Front End™ that is accessible through 10 analog and I/O pins (AIO<9:0>). These pins can be configured to form flexible interconnected circuitry made up of 3 differential programmable gain amplifiers, 4 single-ended programmable gain amplifiers, 4 general purpose comparators, 3 phase comparators, 10 protection comparators, and one buffer output. These pins can also be programmed as analog feed-through pins, or as analog front end I/O pins that can function as digital inputs or digital open-drain outputs. The PAC proprietary configurable analog signal matrix (CASM) and configurable digital signal matrix (CDSM) allow real time asynchronous analog and digital signals to be routed in flexible circuit connections for different applications. A push-button function is provided for optional push button on, hibernate, and off power management function.

The CAFE also contains a power monitor MUX that allows all available power supplies to be sampled by the ADC for control and operation of the application.

7.3.1 Differential Programmable Gain Amplifier (DA)

The DAXP and DAXN pin pair are positive and negative inputs, respectively, to a differential programmable gain amplifier. The differential gain can be programmable to be 1x, 2x, 4x, 8x, 16x, 32x, and 48x for zero-ohm signal source impedance. The differential programmable gain amplifier has -0.3V to 3.5V input common mode range, and its output can be configured for routing directly to the ADC pre-multiplexer, or through a sample-and-hold circuit synchronized with the ADC auto-sampling mechanism. Each differential amplifier is accompanied by offset calibration circuitry, and two protection comparators for protection event monitoring. The programmable gain differential amplifier is optimized for use with signal source impedance lower than 500Ω and with matched source impedance on both positive and negative inputs for minimal offset. The effective gain is scaled by $13.5k / (13.5k + R_{SOURCE})$, where R_{SOURCE} is the matched source impedance of each input.

7.3.2 Single-Ended Programmable Gain Amplifier (AMP)

Each AMPx input goes to a single-ended programmable gain amplifier with signal relative to V_{SS} . The amplifier gain can be programmed to be 1x, 2x, 4x, 8x, 16x, 32x, and 48x, or as analog feed-through. The programmable gain amplifier output is routed via a multiplexer to the configurable analog signal matrix CASM.

7.3.3 General-Purpose Comparator (CMP)

The general-purpose comparator takes the CMPx input and compares it to either the programmable threshold voltage (V_{THREF}) or a signal from the configurable analog signal matrix CASM. The comparator has 0V to V_{SYS} input common mode range, and its polarity-selectable output is routed via a multiplexer to either a data input bit or the configurable digital signal matrix CDSM. Each general-purpose comparator has two mask bits to prevent or allow rising or falling edge of its output to trigger second microcontroller interrupt INT2, where INT2 can be configured to active protection event PR1.

7.3.4 Phase Comparator (PHC)

The phase comparator takes the PHCx input and compares it to either the programmable threshold voltage (V_{THREF}) or a signal from the configurable analog signal matrix CASM. The comparison signal can be set to a phase reference signal generated by averaging the PHCx input voltages. In a three-phase motor control application, the phase reference signal acts as a virtual center tap for BEMF detection. The PHCx inputs are optionally fed through to the CASM. The PHC inputs can be compared to the virtual center-tap, or phase to phase for the most efficient BEMF zero-cross detection. The phase comparators have configurable asymmetric hysteresis.

The phase comparator has 0V to V_{SYS} input common mode range, and its polarity-selectable output is routed to a data input bit and to the phase/position multiplexer synchronized with the auto-sampling sequencers.

High Pin-Count 70V Motor Controller and Driver for BLDC Motors

7.3.5 Protection Comparator (PCMP)

Two protection comparators are provided in association with each differential programmable gain amplifier, with outputs available to trigger protection events and accessible as read-back output bits. The high-speed protection (HP) comparator compares the PCMPx pin to the 8-bit HP DAC output voltage, with full scale voltage of 2.5V. The limit protection (LP) comparator compares the differential programmable gain amplifier output to the 10-bit LP DAC output voltage, with full scale voltage of 2.5V.

Each protection comparator has a mask bit to prevent or allow it to trigger the main microcontroller interrupt INT1. Each protection comparator also has one mask bit to prevent or allow it to activate protection event PR1, and another mask bit to prevent or allow it to activate protection event PR2. These two protection events can be used directly by protection circuitry in the Application Specific Power Driver™ (ASPD) to protect devices being driven.

7.3.6 Analog Output Buffer (BUF)

A subset of the signals from the configurable analog signal matrix CASM can be multiplexed to the BUF6 pin for external use. The buffer offset voltage can be minimized with the built-in swap function.

7.3.7 Analog Front End I/O (AIO)

There are 10 AIOx pins that are available in the device. When the AIO pins are in I/O mode, the pin can be configured to be a digital input or digital open-drain output. The AIOx input or output signal can be set to a data input or output register bit or multiplexed to one of the signals in the configurable digital signal matrix CDSM. The signal can be set to active high (default) or active low, with V_{SYS} as the supply rail. AIO<9:6> support microcontroller interrupts for external signals. Each of these I/Os has two mask bits to prevent or allow rising or falling edge of its corresponding digital input to trigger second microcontroller interrupt INT2.

7.3.8 Push Button (PBTN)

AIO6 may be configured as a push-button input that is used to wake-up the PAC5524 when it is in hibernate mode. Before entering hibernate mode, the MCU can configure AIO6 to be a wake-up source to exit hibernate mode. When a high-to-low transition is observed on AIO6, the CAFE will wake-up the device.

In addition, the PBTN may be used as a hardware reset for the MCU when it is held low for longer than 8s during normal operation.

The PBTN input is active-low and a 55k resistor that is pulled-up to 3V. Pulling this signal to ground externally will raise the push-button event.

7.3.9 HP DAC and LP DAC

The 8-bit HP DAC can be used as the comparison voltage for the high-speed protection (HP) comparators or routed for general purpose use via the AB2 signal in the CASM. The HP DAC output full scale voltage is 2.5V.

The 10-bit LP DAC can be used as the comparison voltage for the limit protection (LP) comparators or routed for general purpose use via the AB3 signal in the CASM. The LP DAC output full scale voltage is 2.5V.

7.3.10 ADC Analog Input

The PAC5524 has several different analog input channels that may be used for analog-to-digital conversions using the MCU ADC. The diagram below shows the hierarchy of MUXes that are available for analog signal sampling.

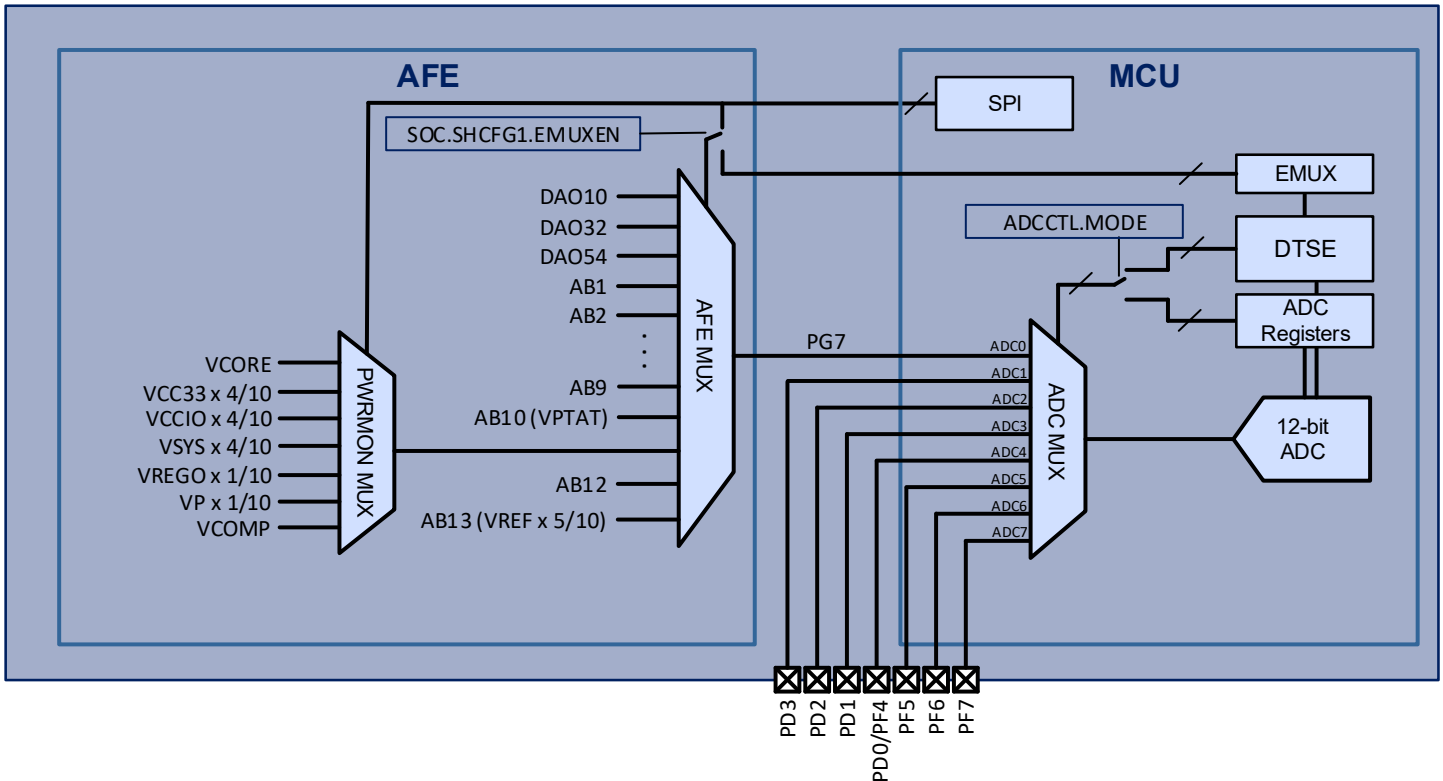

Figure 9 ADC Analog Input

The PAC5524 contains three analog MUXes as shown in the figure above:

- ADC MUX
- AFE MUX
- PWRMON MUX

The ADC MUX is an 8-channel MUX local to the ADC on the MCU that is directly controlled either by registers in the MCU, or automatically by the ADC DTSE. The output of the ADC MUX is sampled by the ADC. The ADC0 input to the ADC MUX is connected to the AFE MUX through the PG7 IO (which is internal to the device). ADC MUX input channels ADC1-ADC7 are directly connected to the pins on the PAC5524 on the IOs shown in the figure above

The AFE MUX is a 16-to-1 MUX that selects between the DA outputs, analog bus channels, voltage reference and the internal temperature sensor (VPTAT). This allows the ADC to rapidly sample the motor phase current, external voltage and temperature signals and the internal device temperature using the hardware sequencer on the device (DTSE).

The PWRMON MUX is a 8-to-1 MUX that selects between the power supply rails and comparator outputs. This MUX may be changed using the SPI bus by changing the MUX select register for this MUX.

For more information on controlling the various MUXes using the ADC and DTSE, see the PAC5524 User Guide.

High Pin-Count 70V Motor Controller and Driver for BLDC Motors

7.3.11 Configurable Analog Signal Matrix (CASM)

The CASM has 12 general purpose analog signals labeled AB1 through AB12 that can be used for:

- Routing the single-ended programmable gain amplifier or analog feed-through output to AB1 through AB9
- Routing an analog signal via AB1, AB2, or AB3 to the negative input of a general-purpose comparator or phase comparator
- Routing the 8-bit HP DAC output to AB2
- Routing the 10-bit LP DAC output to AB3
- Routing analog signals via AB1 through AB12 to the ADC pre-multiplexer
- Routing phase comparator feed-through signals to AB7, AB8, and AB9, and averaged voltage to AB1

7.3.12 Configurable Digital Signal Matrix (CDSM)

The CDSM has 7 general purpose bi-directional digital signals labeled DB1 through DB7 that can be used for:

- Routing the AIOx input to or output signals from DB1 through DB7
- Routing the general-purpose comparator output signals to DB1 through DB7

7.3.13 Temperature Protection

The PAC5524 has two level of temperature protection. When the device reaches an internal temperature of 140°C, there is a mask-able interrupt that may be generated on IRQ1 to the MCU. The MCU may use this information to change the application behavior or disable the motor. The temperature warning status is cleared when the internal temperature falls below the temperature warning hysteresis threshold after the blanking time.

When the device reaches an internal temperature of 170C, the device will shut down all power supplies and gate drivers. The device will re-start when the internal temperature falls below the temperature fault hysteresis threshold after the blanking time.

7.4 Electrical Characteristics

The Electrical Characteristics for the CAFE are shown below.

7.4.1 Differential Programmable Gain Amplifier (DA)

Table 4 DA Electrical Characteristics

Symbol	Parameter	Conditions	Min.	Typ.	Max.	Units
$I_{CC,DA}$	Operating supply current	Each enabled amplifier		150	300	μ A
$V_{ICMR,DA}$	Input common mode range		-0.3		3.5	V
$V_{OLR,DA}$	Output linear range		0.1		$V_{SYS} - 0.1$	V
$V_{SHR,DA}$	Sample and hold range		0.1		3.5	
$V_{OS,DA}$	Input offset voltage	Gain = 48x, $V_{DAxP}=V_{DAxN}=0V$, $T_A=25^\circ C$	-8		8	mV
$A_{VZI,DA}$	Differential amplifier gain (zero ohm source impedance)	Gain = 1x		1		
		Gain = 2x		2		
		Gain = 4x		4		
		Gain = 8x, $V_{DAxP}=V_{DAxN}=0V$, $T_A = 25^\circ C$		8		
			-2		2	%
		Gain = 16x		16		
		Gain = 32x		32		
	Gain = 48x		48			
$K_{CMRR,DA}$	Common mode rejection ratio	Gain = 8x, $V_{DAxP}=V_{DAxN}=0V$, $T_A = 25^\circ C$		55		dB
$R_{INDIF,DA}$	Differential input impedance			27		k Ω
	Slew rate ¹	Gain = 8x	7	10		V/ μ s
$t_{ST,DA}$	Settling time ¹	To 1% of final value		200	400	ns

$T_A = -40^\circ C$ to $125^\circ C$ unless otherwise specified

¹ Guaranteed by design

High Pin-Count 70V Motor Controller and Driver for BLDC Motors

7.4.2 Single-Ended Programmable Gain Amplifier (SA)

Table 5 SA Electrical Characteristics

Symbol	Parameter	Conditions	Min.	Typ.	Max.	Units
I _{CC,AMP}	Operating supply current	Each enabled amplifier		80	140	μA
V _{ICMR,AMP}	Input common mode range		0		V _{sys}	V
V _{OLR,AMP}	Output linear range		0.1		V _{sys} - 0.1	V
V _{OS,AMP}	Input offset voltage	Gain = 1x, T _A =25°C, V _{AMPX} =2.5V	-10		10	mV
A _{V,AMP}	Amplifier gain	Gain = 1x		1		
		Gain = 2x		2		
		Gain = 4x		4		
		Gain = 8x, V _{AMPX} =125mV, T _A = 25°C	-2		2	%
		Gain = 16x		16		
		Gain = 32x		32		
		Gain = 48x		48		
I _{IN,AMP}	Input current			0	1	μA
	Slew rate ²	Gain = 8x	8	12		V/μs
t _{ST,AMP}	Settling time ²	To 1% of final value		150	300	ns

T_A = -40°C to 125°C unless otherwise specified

7.4.3 General Purpose Comparator (CMP)

Table 6 CMP Electrical Characteristics

Symbol	Parameter	Conditions	Min.	Typ.	Max.	Units
I _{CC,CMP}	Operating supply current	Each enabled amplifier		35	110	μA
V _{ICMR,CMP}	Input common mode range		0		V _{sys}	V
V _{OS,CMP}	Input offset voltage	V _{CMPX} =2.5V, T _A =25°C	-10		10	mV
V _{HYS,CMP}	Hysteresis			20		mV
I _{IN,CMP}	Input current			0	1	μA
t _{DEL,CMP}	Comparator delay ²				100	ns

T_A = -40°C to 125°C unless otherwise specified.

² Guaranteed by design



PAC5524

High Pin-Count 70V Motor Controller and Driver for BLDC Motors

7.4.4 Phase Comparator (PHC)

Table 7 PHC Electrical Characteristics

Symbol	Parameter	Conditions	Min.	Typ.	Max.	Units
I _{CC,PHC}	Operating supply current	Each enabled amplifier		35	110	μA
V _{ICMR,PHC}	Input common mode range		0		V _{sys}	V
V _{OS,PHC}	Input offset voltage	V _{PCMPx} =2.5V, T _A =25°C	-10		10	mV
V _{HYS,PHC}	Hysteresis			20		mV
I _{IN,PHC}	Input current			0	1	μA
t _{DEL,PHC}	Comparator delay ³				100	ns

T_A = -40°C to 125°C unless otherwise specified.

7.4.5 Protection Comparator (PCMP)

Table 8 PCMP Electrical Characteristics

Symbol	Parameter	Conditions	Min.	Typ.	Max.	Units
I _{CC,PCMP}	Operating supply current	Each enabled comparator		35	100	μA
V _{ICMR,PCMP}	Input common mode range		0.3		V _{sys} -1	V
V _{OS,PCMP}	Input offset voltage	V _{PCMPx} =2.5V, T _A =25°C	-10		10	mV
V _{HYS,PCMP}	Hysteresis			20		mV
I _{IN,PCMP}	Input current			0	1	μA
t _{DEL,PCMP}	Comparator delay ¹				100	ns

T_A = -40°C to 125°C unless otherwise specified.

7.4.6 Analog Output Buffer (BUF)

Table 9 BUF Electrical Characteristics

Symbol	Parameter	Conditions	Min.	Typ.	Max.	Units
I _{CC,BUF}	Operating supply current	No load		35	100	μA
V _{ICMR,BUF}	Input common mode range		0		3.5	V
V _{OLR,AMP}	Output linear range		0.1		3.5	V
V _{OS,BUF}	Offset voltage	V _{BUF} = 2.5V, T _A = 25°C	-18		18	mV
I _{OMAX}	Maximum output current	C _L = 0.1nF	0.8	1.3		mA

T_A = -40°C to 125°C unless otherwise specified.

³ Guaranteed by design

High Pin-Count 70V Motor Controller and Driver for BLDC Motors

7.4.7 Analog Front End (AIO) Electrical Characteristics

Table 10 AIO Electrical Characteristics

Symbol	Parameter	Conditions	Min.	Typ.	Max.	Units
V _{AIO}	Pin voltage range		0		5	V
V _{IH;AIO}	High-level input voltage		2.2			V
V _{IL;AIO}	Low-level input voltage				0.8	V
R _{PD;AIO}	Pull-down resistance	Input mode	0.5	1	1.8	MΩ
V _{OL;AIO}	Low-level output voltage	I _{AIO<9,7,3,1>=7mA} , open-drain output mode			0.4	V
		I _{AIO<6,0>=7mA} , open-drain output mode			0.5	
I _{OL;AIO}	Low-level output sink current	V _{AIOx} = 0.4V, open-drain output mode	6	14		mA
I _{LK;AIO}	High-level output leakage current	V _{AIOx} = 5V, open-drain output mode		0	10	μA

T_A = -40°C to 125°C unless otherwise specified

7.4.8 Push-Button (PBTN) Electrical Characteristics

Table 11 PBTN Electrical Characteristics

Symbol	Parameter	Conditions	Min.	Typ.	Max.	Units
V _{I;PBTN}	Input voltage range		0		5	V
V _{IH;PBTN}	High-level input voltage		2			V
V _{IL;PBTN}	Low-level input voltage				0.35	V
R _{PU;PBTN}	Pull-up resistance	To 3V, push-button input mode	40	55	95	kΩ

T_A = -40°C to 125°C unless otherwise specified

7.4.9 HP DAC and LP DAC Electrical Characteristics

Table 12 HPDAC and LPDAC Electrical Characteristics

Symbol	Parameter	Conditions	Min.	Typ.	Max.	Units
V _{DACREF}	DAC reference voltage	T _A = 25°C	2.48	2.5	2.52	V
		T _A = -40°C to 125°C	2.453	2.5	2.547	
	HP 8-bit DAC INL ⁴		-1		1	LSB
	HP 8-bit DAC DNL ⁴		-0.5		0.5	LSB
	LP 10-bit DAC INL ⁴		-2		2	LSB
	LP 10-bit DAC DNL ⁴		-1		1	LSB

T_A = -40°C to 125°C unless otherwise specified

⁴ Guaranteed by design



PAC5524

High Pin-Count 70V Motor Controller and Driver for BLDC Motors

7.4.10 Temperature Protection Electrical Characteristics

Table 13 PBTN Electrical Characteristics

Symbol	Parameter	Conditions	Min.	Typ.	Max.	Units
T _{WARN}	Temperature warning threshold			140		°C
T _{WARN;HYS}	Temperature warning hysteresis			10		°C
T _{WARN;BLANK}	Temperature warning blanking			10		μs
T _{FAULT}	Temperature fault threshold			165		°C
T _{FAULT;HYS}	Temperature fault hysteresis			10		°C
T _{FAULT;BLANK}	Temperature fault blanking			10		μs

7.5 Typical Performance Characteristics

(T_A = -25°C unless otherwise specified)

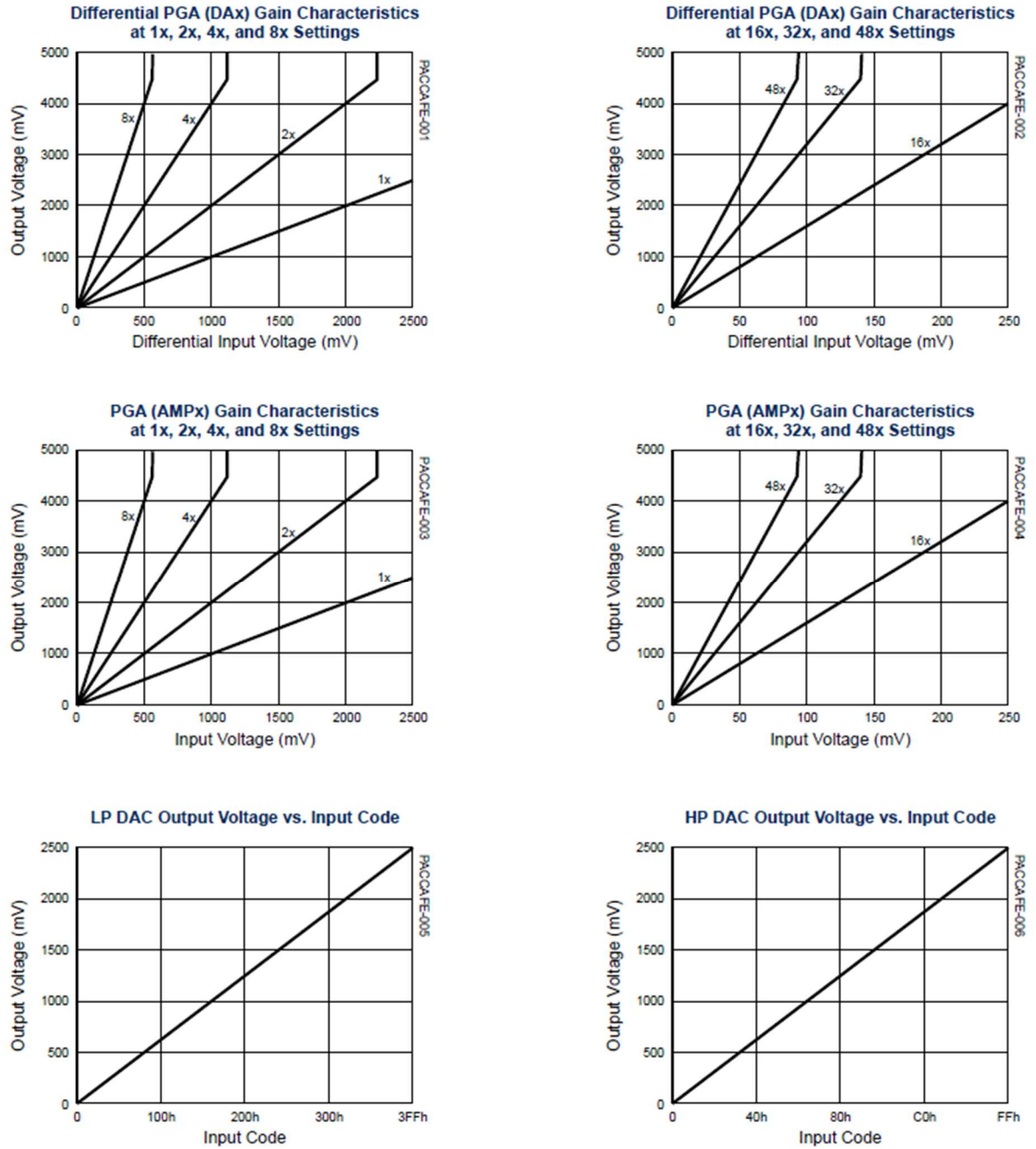

Figure 10 PGA Typical Performance Characteristics

8 Application Specific Power Drivers (ASPD)

8.1 Features

- 3 low-side and 3 high-side gate drivers
- 1.5A gate driving capability
- Break-before-make Dead-Time Enforcement
- OC, UV and OV Protection

8.2 System Block Diagram

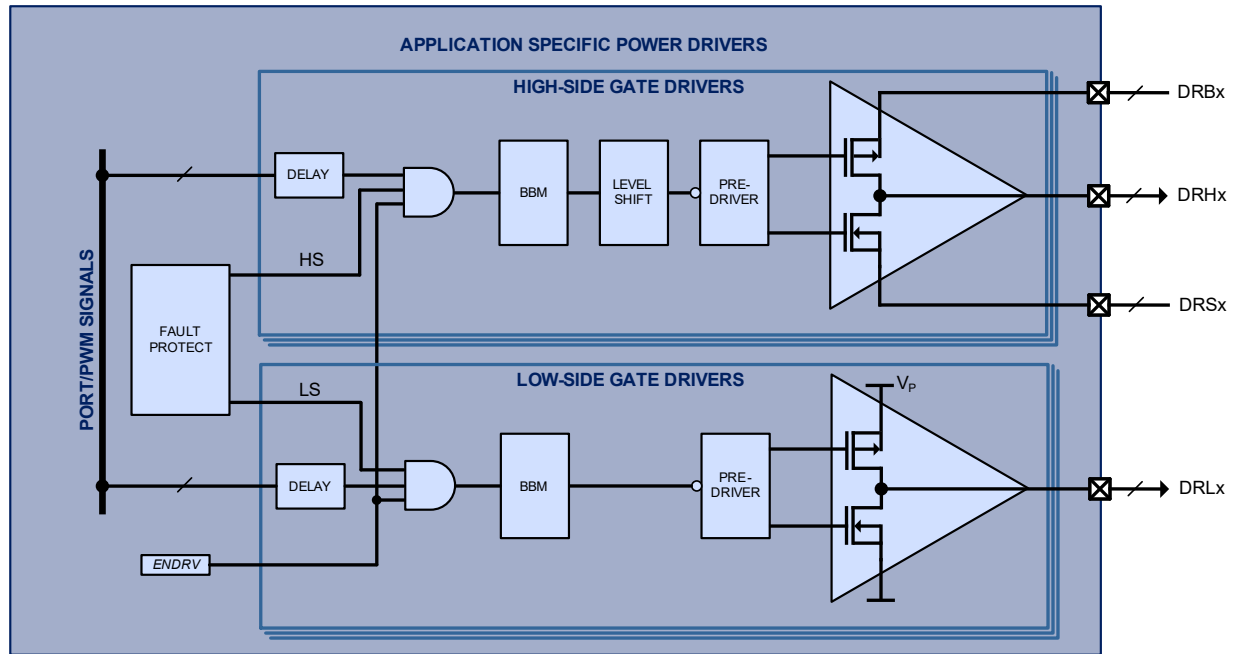

Figure 11 ASPD System Block Diagram

8.3 Functional Description

The Application Specific Power Drivers™ (ASPD) module handles power driving for power and motor control applications. The ASPD contains three low-side gate drivers (DRLx), three high-side gate drivers (DRHx). Each gate driver can drive an external MOSFET or IGBT switch in response to high-speed control signals from the microcontroller ports, and a pair of high-side and low-side gate drivers can form a half-bridge driver.

The ASPD includes built-in configurable fault protection for the internal gate drivers.

The figure below shows typical gate driver connections. The ASPD gate drivers support up to a 70V supply.

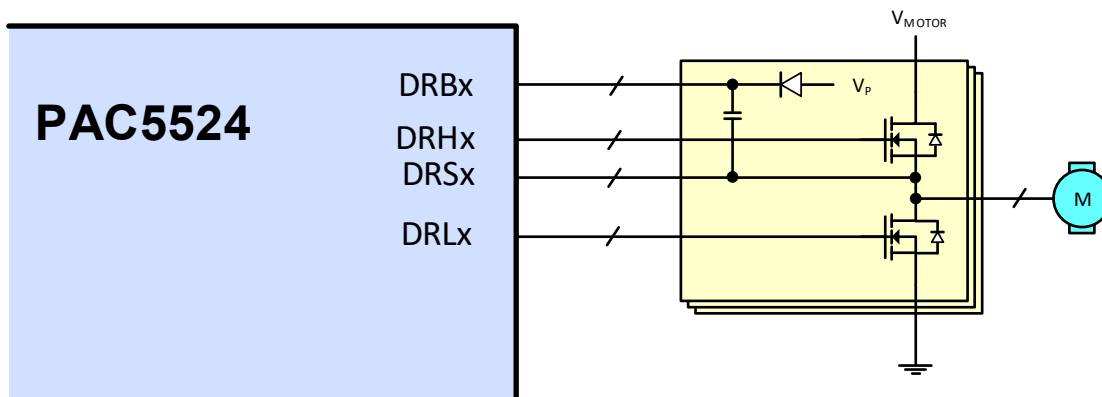

Figure 12 Typical Gate Driver Connections

8.4 Low-Side Gate Drivers

The DRLx low-side gate driver drives the gate of an external MOSFET or IGBT switch between the low-level power ground rail and high-level VP supply rail. The DRLx output pin has sink and source output current capability of 1.5A. Each low-side gate driver is controlled by a microcontroller port signal with 4 configurable levels of propagation delay.

8.5 High-Side Gate Drivers

The DRHx high-side gate driver drives the gate of an external MOSFET or IGBT switch between its low-level DRSx driver source rail and its high-level DRBx bootstrap rail. The DRSx pin can go up to 70V steady state. The DRHx output pin has sink and source output current capability of 1.5A. The DRBx bootstrap pin can have a maximum operating voltage of 16V relative to the DRSx pin, and up to 82V steady state. The DRSx pin is designed to tolerate momentary switching negative spikes down to -5V without affecting the DRHx output state. Each high-side gate driver is controlled by a microcontroller port signal with 4 configurable levels of propagation delay.

For bootstrapped high-side operation, connect an appropriate capacitor between DRBx and DRSx and a properly rated bootstrap diode from VP to DRBx. To operate the DRHx output as a low-side gate driver, connect its DRBx pin to VP and its DRSx pin to VSS.

8.6 High-Side Switching Transients

Typical high-side switching transients are shown below. To ensure functionality and reliability, the DRSx and DRBx pins must not exceed the peak and undershoot limit values shown. This should be verified by probing the DRBx and DRSx pins directly relative to VSS pin. A small resistor and diode clamp for the DRSx pin can be used to make sure that the pin voltage stays within the negative limit value. In addition, the high-side slew rate dV/dt must be kept within $\pm 5V/ns$ for DRSx. This can be achieved by adding a resistor-diode pair in series, and an optional capacitor in parallel with the power switch gate. The parallel capacitor also provides a low impedance and close gate shunt against coupling from the switch drain. These optional protections and slew rate control are shown in the figure below.

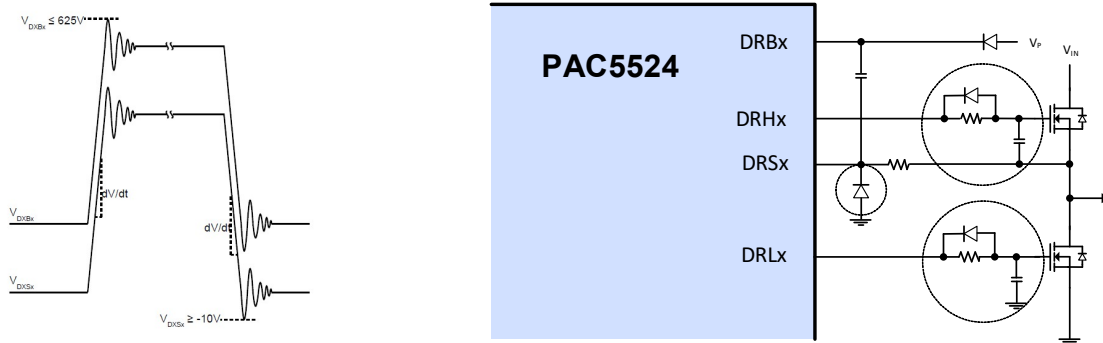

(a) High-Side Switching Transients

(b) Optional Transient Protection and Slew Rate Control

Figure 13 High-Side Switching Transients and Optional Circuitry

8.7 Power Drivers Control

All power drivers are initially disabled from power-on-reset. To enable the power drivers, the microprocessor must first set the driver enable bit to '1'. The gate drivers are controlled by the microcontroller ports and/or PWM signals as shown in **Error! Reference source not found.** The drivers have configurable delays as shown in Table 14 Power Driver Delay Configuration. Refer to the PAC application notes and user guide for additional information on power drivers control programming.

Table 14 Power Driver Delay Configuration

Delay Setting	DRLx		DRHx	
	Rising	Falling	Rising	Falling
00b	130ns	140ns	160ns	140ns
01b	170ns	180ns	200ns	180ns
10b	230ns	250ns	260ns	240ns
11b	360ns	380ns	380ns	370ns



PAC5524

High Pin-Count 70V Motor Controller and Driver for BLDC Motors

8.8 Gate Driver Fault Protection

The ASPD incorporates a configurable fault protection mechanism using protection signal from the Configurable Analog Front End (CAFE), designated as protection event 1 (PR1) signal. The DRL0/DRL1/DRL2 drivers are designated as low-side group 1. The DRH3/DRH4/DRH5 gate drivers are designated as high-side group 1. The PR1 signal from the CAFE can be used to disable low-side group 1, high-side group 1, or both depending on the PR1 mask bit settings.

High Pin-Count 70V Motor Controller and Driver for BLDC Motors

8.9 Electrical Characteristics

The Electrical Characteristics for the ASPD are shown below.

8.9.1 Low-Side Gate Drivers

Table 15 Low-Side Gate Drivers Electrical Characteristics

Symbol	Parameter	Conditions	Min.	Typ.	Max.	Units
$V_{OH;DRL}$	High-level output voltage	$I_{DRLx} = -50\text{mA}$	$V_P-0.5$	$V_P-0.25$		V
$V_{OL;DRL}$	Low-level output voltage	$I_{DRLx} = 50\text{mA}$		0.175	0.35	V
$I_{OHPK;DRL}$	High-level pulsed peak source current	10 μs pulse		-1.5		A
$I_{OLPK;DRL}$	Low-level pulsed peak sink current	10 μs pulse		1.5		A

$V_P = 12\text{V}$ and $T_A = -40^\circ\text{C}$ to 125°C unless otherwise specified

8.9.2 High-Side Gate Drivers

Table 16 High-Side Gate Drivers Electrical Characteristics

Symbol	Parameter	Conditions	Min.	Typ.	Max.	Units
V_{DRS}	Level-shift driver source voltage range	Repetitive, 10 μs pulse	-5		71	V
		Steady state	0		66	V
V_{DRB}	Bootstrap pin voltage range	Repetitive, 10 μs pulse	3		83	V
		Steady state	5.2		78	V
$V_{BS;DRB}$	Bootstrap supply voltage range	V_{DRBx} , relative to respective V_{DRSx}	5.2		16	V
$V_{UVLO;DRB}$	Bootstrap UVLO threshold	V_{DRBx} rising, relative to respective V_{DRSx} , hysteresis = 1V		3.5	4.5	V
$I_{BS;DRB}$	Bootstrap circuit supply current	Gate Driver Disabled		23	35	μA
		Gate Driver Enabled		30	45	
$I_{OS;DRB}$	Offset supply current	Gate Driver Disabled		0.5	10	μA
		Gate Driver Enabled		0.5	10	
$V_{OH;DRH}$	High-Level output voltage	$I_{DRHx} = -50\text{mA}$	$V_{DRBx}-0.6$	$V_{DRBx}-0.2$		V
$V_{OL;DRH}$	Low-level output voltage	$I_{DRHx} = 50\text{mA}$		$V_{DRSx}+0.175$	$V_{DRSx}+0.35$	V
$I_{OHPK;DRH}$	High-level pulsed peak source current	10 μs pulse		-1.5		A
$I_{OLPK;DRL}$	Low-level pulsed peak sink current	10 μs pulse		1.5		A

$V_P = 12\text{V}$ and $T_A = -40^\circ\text{C}$ to 125°C unless otherwise specified

High Pin-Count 70V Motor Controller and Driver for BLDC Motors

8.9.3 High-Side and Low-Side Gate Driver Propagation Delay

Table 17 Gate Driver Propagation Delay Electrical Characteristics

Symbol	Parameter	Conditions	Min.	Typ.	Max.	Units
t_{PD}	Propagation Delay	Delay setting 00b		10		ns
		Delay setting 01b		50		ns
		Delay setting 10b		120		ns
		Delay setting 11b		250		ns

$V_P = 12V$ and $T_A = -40^{\circ}C$ to $125^{\circ}C$ unless otherwise specified

8.10 Typical Performance Characteristics

(VP = 12V and TA = -25°C unless otherwise specified)

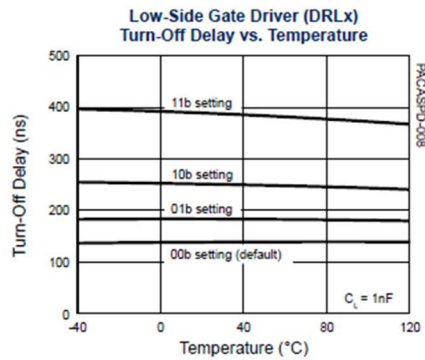
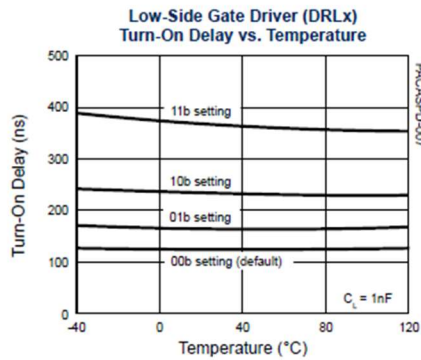
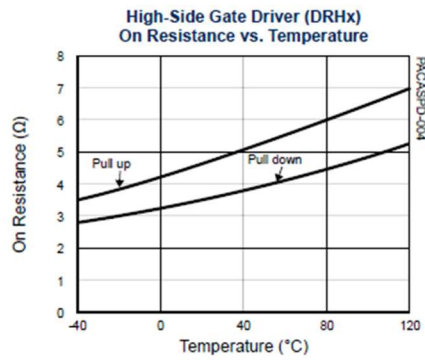
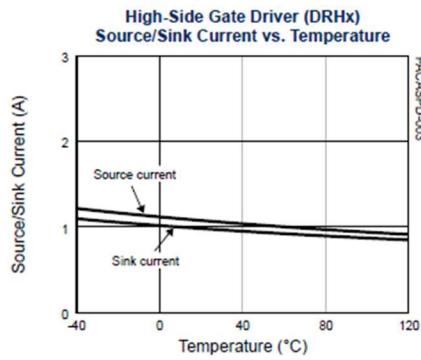
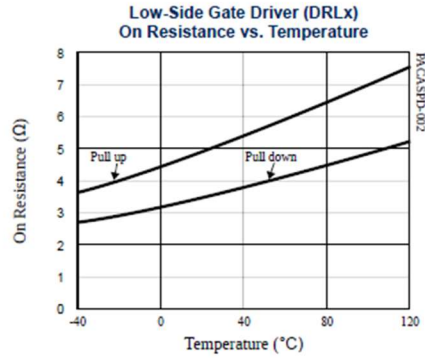
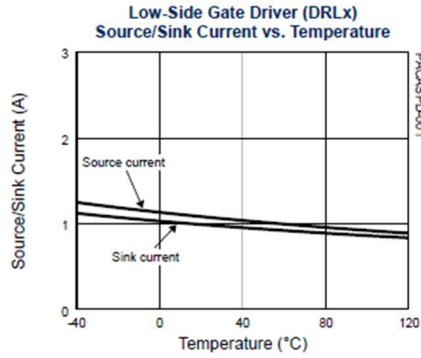

High Pin-Count 70V Motor Controller and Driver for BLDC Motors

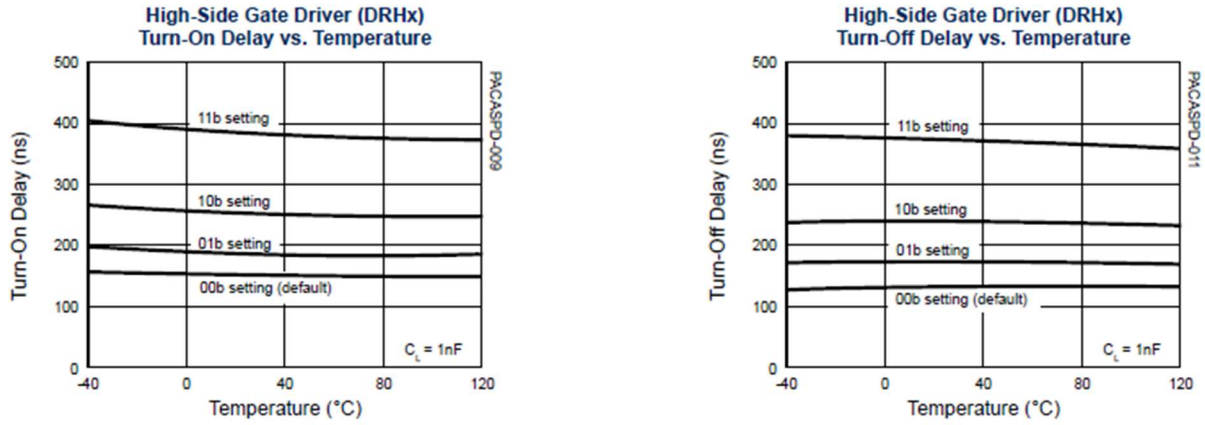

Figure 14 ASPD Gate Driver Typical Performance Characteristics

9 SOC Control Signals

The MCU has access to the Analog Sub-system on the PAC5524 through certain digital peripherals. The functions that the MCU may access from the Analog Sub-System are:

- High-side and Low-side Gate Drivers
- SPI Interface for Analog Register Access
- ADC EMUX
- Analog Sub-system Interrupts

9.1 High-side and Low-Side Gate Drivers

The high-side and low-side gate drivers on the PAC5524 are controlled by PWM outputs of the timer peripherals on the MCU. The timer peripheral generates the PWM output. The PWM timer may be configured to generate a complementary PWM output (high-side and low-side gate drive signals) with hardware controlled dead-time.

These signals are sent to the gate drivers in the Analog Sub-system that create the high and low side gate drivers for the external inverter.

The user may choose to enable or not enable the DTG (Dead-time Generator). The diagram below shows the block diagram of the PWM timer, DTG and ASPD gate drivers.

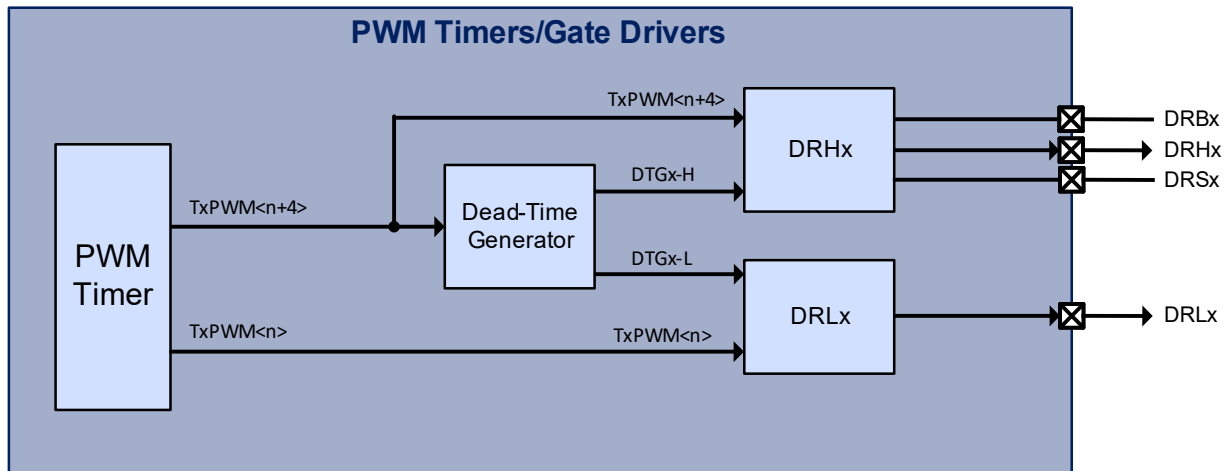

Figure 15 SOC Signals for Gate Drivers

Each timer peripheral that drives the DTG and ASPD Gate Drivers has two PWM outputs that are connected to the gate drivers: $TxPWM<n>$ and $TxPWM<n+4>$. If the Dead-Time Generator is disabled $TxPWM<n>$ is connected to the DRLx gate driver output and $TxPWM<n+4>$ is connected to the DRHx gate driver output.

If the DTG is enabled, the $TxPWM<n+4>$ is used to generate the complementary high-side and low-side output ($DTGx-H$ and $DTGx-L$). $DTGx-H$ is connected to the DRHx output and $DTGx-L$ is connected to the DRLx output.

The MCU allows flexibility the assignment of PWM outputs to ASPD gate drivers. The tables below shows which PWM outputs are available for each gate driver.



PAC5524

High Pin-Count 70V Motor Controller and Driver for BLDC Motors

For applications that drive half-bridge or full-bridge topologies, the DTG will be enabled to allow a complementary output with dead-time insertion.

Table 18 PWM to ASPD Gate Driver Options (DTG Enabled)

Gate Driver	PWM Input Options
DRH3/DRL0	TAPWM4 TBPWM4 TCPWM0 TCPWM4 TDPWM4
DRH4/DRL1	TAPWM5 TBPWM5 TCPWM1 TCPWM5 TDPWM5
DRH5/DRL2	TAPWM6 TBPWM6 TCPWM2 TCPWM6 TDPWM6

High Pin-Count 70V Motor Controller and Driver for BLDC Motors

For applications that are not driving half-bridge topologies, the DTG is disabled and the PWM outputs are directly connected to the gate drivers.

Table 19 PWM to ASPD Gate Driver Options (DTG Enabled)

Gate Driver	PWM Input Options
DRH3	TAPWM4 TBPWM4 TCPWM0 TCPWM4 TDPWM4
DRH4	TAPWM5 TBPWM5 TCPWM1 TCPWM5 TDPWM5
DRH5	TAPWM6 TBPWM6 TCPWM2 TCPWM6 TDPWM6
DRL0	TAPWM0 TBPWM0 TCPWM0 TDPWM0
DRL1	TAPWM1 TBPWM1 TCPWM1 TDPWM1
DRL2	TAPWM2 TBPWM2 TCPWM2 TDPWM2

High Pin-Count 70V Motor Controller and Driver for BLDC Motors

9.2 SPI SOC Bus

The SPI SOC bus is used for reading and writing registers in the Analog Sub-System. The PAC5524 allows both USARTA and USARTB to be used as the SPI master to read and write registers in the Analog Sub-System.

The table below shows which peripherals and which IO pins should be used for this interface.

Table 20 SPI SOC Bus Connections

SPI Signal	USART Signal	IO Pin
SCLK	USASCLK	PA3
	USBCLK	PA3
MOSI	USAMOSI	PA4
	USBMOSI	PA4
MISO	USAMISO	PA5
	USBMISO	PA5
SS	USASS	PA6
	USBSS	PA6

9.3 ADC EMUX

The ADC EMUX is a write-only serial bus that the ADC DTSE uses for instructing the CAFE to perform MUX changes, activate Sample and Hold, etc.

The table below shows the MCU pins that are used by the ADC EMUX in the PAC5524.

Table 21 ADC EMUX SOC Bus Connections

SPI Signal	USART Signal	IO Pin
SCLK	USASCLK	PA3
	USBCLK	PA3

9.4 Analog Interrupts

The Analog sub-system has two interrupts that it can generate for different conditions. The table below shows the two different interrupts, the interrupt conditions and the IO pin that the interrupts are connected to.

Table 22 Analog Interrupt SOC Bus Connections

SPI Signal	USART Signal	IO Pin
nIRQ1	HPCOMP/LPCOMP Comparator Protection for Over-current and Over-Voltage events	PA7
nIRQ2	BEMF and Special Mode Comparator, including phase to phase comparator, AIO6/AIO7/AIO8/AIO9 interrupt	PA0

10 ADC/DTSE

10.1 Features

- 10-bit 1MSPS SAR ADC
- Configurable Dynamic Triggering and Sequence Engine (DTSE)
- High-speed sample and hold for current measurement
- Current, power and temperature monitoring using DTSE

10.2 System Block Diagram

Figure 16 ADC/DTSE System Block Diagram

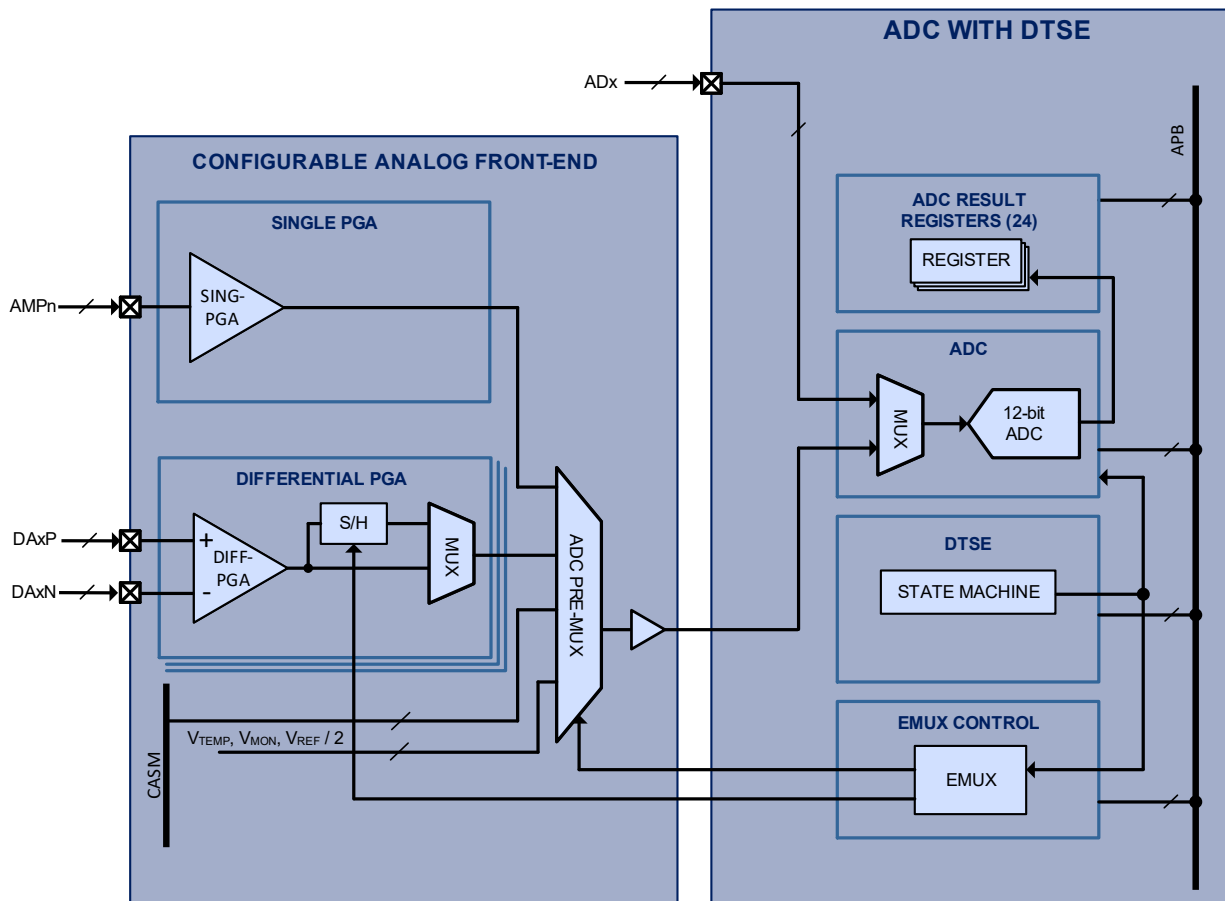

10.3 Functional Description

10.3.1 ADC

The analog-to-digital converter (ADC) is a 12-bit successive approximation register (SAR) ADC with 400ns conversion time and up to 2.5 MSPS capability. The integrated analog multiplexer allows selection from up to 8 direct ADx inputs, and from up to 10 analog inputs signals in the Configurable Analog Front End (CAFE), including up to 3 differential input pairs as well as temperature and $V_{REF} / 2$.

The ADC contains a power down mode, and the user may configure the ADC to interrupt the MCU for the completion of a conversion when in manual mode. The ADC may be configured for either repeating or non-repeating conversions or conversion sequences.

10.3.2 Dynamic Triggering and Sample Engine (DTSE)

The Dynamic Triggering and Sample Engine (DTSE) is a highly-configurable automatic sequencer that allows the user to configure automatic sampling of their application-specific analog signals without any interaction from the micro-controller core. The DTSE also contains a pseudo-DMA engine that copies each of up to 24 conversion results to dedicated memory space and can interrupt the MCU when complete.

The DTSE has up to 32 input triggers, from PWM Timers A, B, C and D for either the rising, falling or rising and falling PWM edges. The user may also force any trigger sequence by writing a register via firmware. The user can configure the DTSE to chain from 1 to 24 conversions to any PWM trigger.

The DTSE has a flexible interrupt structure that allows up to 24 interrupts to be configured at the completion of any individual conversion. The user may configure one of four different IRQ signals when generating an interrupt during sequence conversions. The IRQ may be generated at the end of a conversion sequence, or at the end of a series of conversions. The user may select one of four IRQs for conversions, and each may be assigned a different interrupt priority.

Each of the 24 conversions has dedicated results registers, so that the pseudo-DMA engine has dedicated storage for each of the conversion results.

10.3.3 EMUX Control

A dedicated low latency interface controllable by the DTSE or register control allows changing the ADC pre-multiplexer and asserting/de-asserting the S/H circuit in the Configurable Analog Front-End (CAFE), allowing back to back conversions of multiple analog inputs without microcontroller interaction.

For more information on the ADC and DTSE, see the PAC55XX Family User Guide.

10.4 Electrical Characteristics

The Electrical Characteristics for the ADC and DTSE are shown below.

Table 23 ADC/DTSE Electrical Characteristics

Symbol	Parameter	Conditions	Min.	Typ.	Max.	Units
f_{ADCCLK}	ADC conversion clock input				40	MHz
$f_{ADCCONV}$	ADC conversion time	$f_{ADCCLK} = 40\text{MHz}$; PCx, PDx, PEx, PFx, PGx pins			16	ADCCLK
					400	ns
$t_{ADC,SH}$ t_{ADCSH}	ADC sample and hold time	$f_{ADCCLK} = 40\text{MHz}$; AIO[9:0] pins			800	ns
	ADC sample and hold time				100	ns
$t_{ADC,CVT}$ C_{ADCIC}	ADC analog conversion time	ADC MUX input			4	ADCCLK
	ADC input capacitance			1		pF
	ADC resolution			12		bits
	ADC effective resolution		10.5			bits
	ADC differential non-linearity (DNL)	$F_{ADCCLK} = 25\text{MHz}$		± 0.5		LSB
	ADC resolution	$F_{ADCCLK} = 40\text{MHz}$		± 0.75		LSB
	ADC integral non-linearity (INL)	$F_{ADCCLK} = 25\text{MHz}$		± 0.5		LSB
	ADC differential non-linearity (DNL)	$F_{ADCCLK} = 40\text{MHz}$		± 0.75		LSB
	ADC offset error			0.6		%FS
	ADC gain error			0.12		%FS
V_{REFADC}	ADC reference input voltage	$V_{REF} = 2.5\text{V}$		2.5		V
$f_{EMUXCLK}$	EMUX engine clock input				50	MHz

$T_A = -40^\circ\text{C}$ to 125°C unless otherwise specified

11 Memory System

11.1 Features

- 128kB Program FLASH
 - 30k Program/Erase cycles
 - 10 years data retention
 - FLASH look-ahead buffer for optimizing access
- 1kB INFO-1 FLASH
- 1kB INFO-2 FLASH
 - Device ID, Unique ID, trim and manufacturing data
- 32kB SRAM
 - 150MHz access for code or data
 - SECDE for read/write operations
- User-configurable Code Protection

11.2 System Block Diagram

Figure 17 Memory System Block Diagram

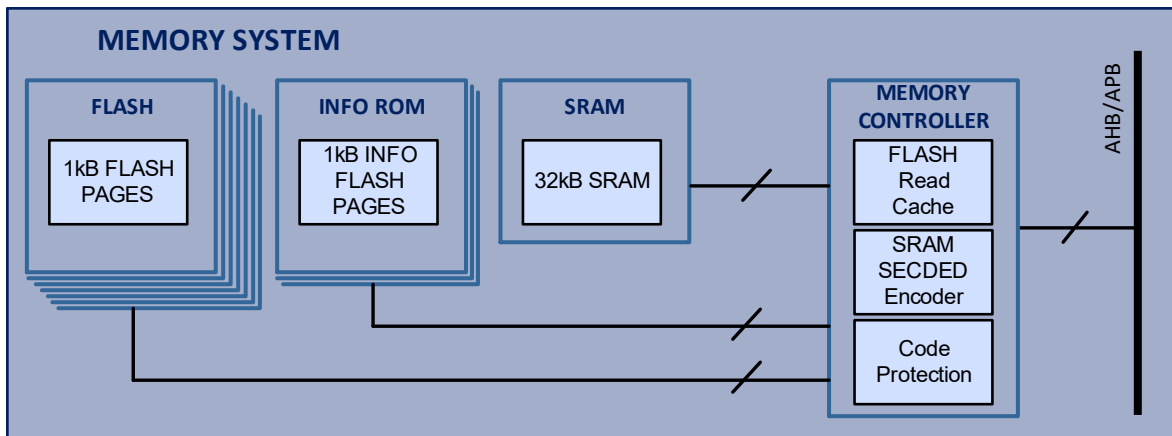

11.3 Functional Description

The PAC5524 contains multiple banks of FLASH memory, SRAM memory as well as peripheral control registers that are accessible to the MCU in a flat memory map.

11.3.1 Program FLASH

The PAC55XX Memory Controller provides access to 128 1kB pages of main program FLASH for a total of 128kB of FLASH through the system AHB bus. Each page may be individually erased or written while the MCU is executing instructions from SRAM.

The PAC55XX Memory Controller provides a FLASH read buffer that optimizes access from the MCU to the FLASH memory. This look ahead buffer monitors the program execution and fetches instructions from FLASH before they are needed to optimize access to this memory.

11.3.2 INFO FLASH

The PAC55XX Memory Controller provides access to the INFO-1, INFO-2 and INFO-3 FLASH memories, which are each a single 1kB page for a total of 3kB of memory.

INFO-1 and INFO-2 are read-only memories that contains device-specific information such as the device ID, a unique ID, trimming and calibration data that may be used by programs executing on the PAC55XX.

INFO-3 is available to the user for data or program storage.

11.3.3 SRAM

The PAC55XX Memory Controller provides access to the 32kB SRAM for non-persistent data storage. The SRAM memory supports word (4B), half-word (2B) and byte addresses.

The PAC55XX Memory Controller can read or write data from RAM up to 150MHz. This can be a benefit for time-critical applications. This memory can also be used for program execution when modifying the contents of FLASH, INFO-1 or INFO-2 FLASH.

The PAC55XX Memory Controller also has an SECDED encoder, capable of detecting and correcting single-bit errors, and detecting double-bit errors. The user may read the status of the encoder, to see if a single-bit error has occurred. The user may also enable an interrupt upon detection of single-bit errors. Dual-bit errors can be configured to generate an interrupt in the PAC55XX.⁵

For more information on the PAC55XX Memory Controller, see the PAC55XX Family User Guide.

⁵ Note that when writing half-word or single bytes to SRAM, the memory controller must perform a read-modify write to memory to perform the SECDED calculation. These operations will take more than one clock cycle to perform for this reason.

High Pin-Count 70V Motor Controller and Driver for BLDC Motors

11.3.4 Code Protection

The PAC5524 allows the user to configure a 4-level code protection scheme to secure code from being read from the device.

There are four levels of code protection available as shown in the table below.

Table 24 Code Protection Levels

Level	Name	Features
0	UNLOCKED	<ul style="list-style-type: none"> No restrictions
1	RW PROTECTION	<ul style="list-style-type: none"> SWD enabled Programmable protection of up to 64 regions of FLASH User-specified Read or Write per region
2	SWD DISABLED	<ul style="list-style-type: none"> SWD disabled Programmable protection of up to 64 regions of FLASH User-specified Read or Write per region
3	SWD PERMANENTLY DISABLED	<ul style="list-style-type: none"> SWD disabled Programmable protection of up to 64 regions of FLASH User-specified Read or Write per region No recovery

11.4 Electrical Characteristics

The Electrical Characteristics for the Memory System are shown below.

Table 25 Memory System Electrical Characteristics

Symbol	Parameter	Conditions	Min.	Typ.	Max.	Units
FLASH						
$t_{\text{READ;FLASH}}$	FLASH word read time		40			ns
$t_{\text{WRITE;FLASH}}$	FLASH word write time		30			μs
$t_{\text{PERASE;FLASH}}$	FLASH page erase time				2	ms
$t_{\text{MERASE;FLASH}}$	FLASH mass erase time				10	ms
$N_{\text{PERASE;FLASH}}$	FLASH program/erase cycles		30k			cycles
$t_{\text{DF;FLASH}}$	FLASH data retention		10			years
SRAM						
$t_{\text{ACC;SRAM}}$	SRAM access time	HCLK = 150MHz; Word (32-bits), aligned	6.67			ns
		HCLK = 150MHz; Half-word (16-bits), byte (8-bits), aligned	6.67			ns

$T_A = -40^\circ\text{C}$ to 125°C unless otherwise specified

12 System and Clock Control (SCC)

12.1 Features

- 20MHz Ring Oscillator
- High-accuracy 2% trimmed 4MHz RC oscillator
- External Clock Input for External Clocks up to 20MHz
- PLL with 1MHz to 50MHz input, 62.5MHz to 300MHz output
- Clock dividers for all system clocks
- Clock gating for power conservation during low-power operation

12.2 System Block Diagram

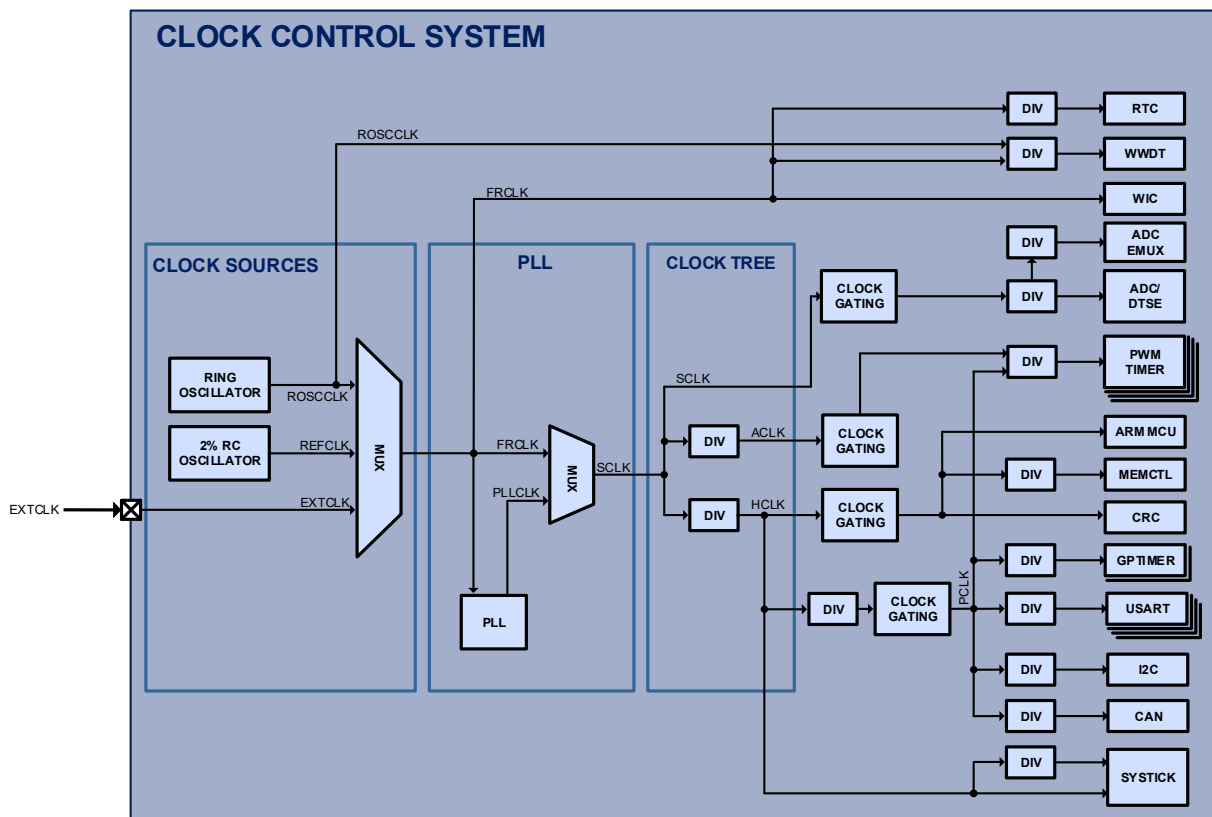

Table 26 Clock Control System Block Diagram

12.3 Functional Description

The Clock Control System (CCS) controls the clock system and clock gating for the PAC5524. There are three independent clock sources: the Ring Oscillator, Reference Clock and External Clock Input.

12.4 Clock Sources

12.4.1 Ring Oscillator

The Ring Oscillator (ROSC) is an integrated 20MHz clock oscillator that is the default system clock, and is available by default when the PAC55XX comes out of reset. The output of the ROSC is the **ROSCCLK** clock. The **ROSCCLK** may be selected as the **FRCLK** clock and may supply the WWDT, for applications that need an independent clock source or need to continue to be clocked when the system is in a low-power mode.

The ROSC may be disabled by the user by a configuration register.

12.4.2 Reference Clock

The Reference Clock (**REFCLK**) is an integrated 2% trimmed 4MHz RC clock. This clock is suitable for many applications. This clock may be selected as the **FRCLK** and can be used as the input to the PLL and is used to derive the clock for the MMPM.

12.4.3 External Clock Input

The External Clock Input (EXTCLK) is a clock input available through the digital peripheral MUX, and allows the drive the clock system by a 50% duty cycle clock of up to 20MHz. This clock may be selected as FRCLK and can be used as the input the PLL (as long as the accuracy is better than +/- 2%).

12.5 PLL

The PAC55XX contains a Phase Lock Loop (PLL) that can generate very high clock frequencies up to 300MHz for the peripherals and timers in the device. The input to the PLL is the **FRCLK** and must be from the **EXTCLK** or **REFCLK** clock sources

The input to the PLL must be between 1MHz – 50MHz and the output can be configured to be from 62.5MHz to 300MHz. The user can configure the PLL to generate the desired clock output based on a set of configuration registers in the CCS. The output of the PLL is the **PLLCLK** clock. The user may configure a MUX to generate the SCLK clock from **PLLCLK** or from **FRCLK**.

In addition to configuring the PLL output frequency, the PLL may be enabled, disabled and bypassed through a set of configuration registers in the CCS.

12.6 Clock Tree

The following are the system clocks available in the clock tree. See the section below to see which clocks are available for each of the digital peripherals in the system.

12.6.1 FRCLK

The free-running clock (**FRCLK**) is generated from one of the four clock sources (**ROSCCLK**, **EXTCLK** or **REFCLK**). This clock may be used by the WWDT and the RTC, for configurations that turn off all other system clocks during low power operation.

The **FRCLK** or **PLLCLK** is selected via a MUX and the output becomes **SCLK**.

12.6.2 SCLK

The System Clock (**SCLK**) generates two system clocks: **ACLK** and **HCLK**. Each of these system clocks has their own 3b clock divider and is described below.



PAC5524

High Pin-Count 70V Motor Controller and Driver for BLDC Motors

12.6.3 PCLK

The Peripheral Clock (**PCLK**) is used by most of the digital peripherals in the PAC55XX. This clock has a 3b clock divider and also has clock gating support, which allows this clock output to be disabled before the system is put into the Arm® Cortex®-M4's deep sleep mode to conserve energy.

As shown above, most of the peripherals that use **PCLK** also have their own clock dividers so that this clock can be further divided down to meet the application's needs.

12.6.4 ACLK

The Auxiliary Clock (**ACLK**) may be optionally used by the PWM timer block in the PAC55XX in order to generate a very fast clock for PWM output to generate the best possible accuracy and edge generation.

This clock has a 3b clock divider and also has clock gating support, which disables this clock output when the system is put into the Arm® Cortex®-M4's deep sleep mode to conserve energy.

As shown above, the **ACLK** is an optional input for just the PWM timer block in the PAC55XX.

12.6.5 HCLK

The AHB Clock (**HCLK**) is used by the Arm® Cortex®-M4 MCU and Memory Controller peripheral. This clock has a 3b divider and also has clock gating support, which allows this clock output to be disabled before the system is put into the Arm® Cortex®-M4's deep sleep mode to conserve energy.

HCLK supplies PCLK with its clock source.

12.7 Electrical Characteristics

The Electrical Characteristics for the System and Clock Control module are shown below.

Table 27 System and Clock Control Electrical Characteristics

Symbol	Parameter	Conditions	Min.	Typ.	Max.	Units
Clock Tree (FRCLK, FCLK, PCLK, ACLK, HCLK)						
f_{FRCLK}	Free-running clock frequency				25	MHz
f_{SCLK}	System clock frequency				300	MHz
f_{PCLK}	Peripheral clock frequency	After PCLK divider			150	MHz
f_{ACLK}	Auxiliary clock frequency	After ACLK divider			300	MHz
f_{HCLK}	High-speed clock frequency	After HCLK divider			150	MHz
Internal Oscillators						
$f_{ROSCCLK}$	Ring oscillator frequency			20		MHz
$f_{TRIM;REFCLK}$	Trimmed RC oscillator frequency	$T_A = 25^\circ\text{C}$	-2%	4	2%	MHz
		$T_A = -40^\circ\text{C}$ to 125°C	-3%	4	3%	MHz
$f_{JITTER;REFCLK}$	Trimmed RC oscillator clock jitter	$T_A = -40^\circ\text{C}$ to 85°C		0.5		%
PLL						
$f_{IN;PLL}$	PLL input frequency range		1		50	MHz
$f_{OUT;PLL}$	PLL output frequency range		62.5		300	MHz
$t_{SETTLE;PLL}$	PLL setting time	$T_A = 25^\circ\text{C}$, PLL settled			15	μs
		$T_A = 25^\circ\text{C}$, PLLLOCK = 1		200	500	μs
$t_{JITTER;PLL}$	PLL period jitter	RMS		25		ps
		Peak to peak			100	ps
	PLL duty cycle		40	50	60	%
External Clock Input (EXTCLK)						
f_{EXTCLK}	External Clock Input Frequency				20	MHz
	External Clock Input Duty Cycle		40		60	%
$V_{IH;EXTCLK}$	External Clock Input high-level input voltage		2.1			V
$V_{IL;EXTCLK}$	External Clock Input low-level input voltage				0.825	V

$T_A = -40^\circ\text{C}$ to 125°C unless otherwise specified

13 Arm® Cortex®-M4F MCU Core

13.1 Features

- Arm® Cortex®-M4F core
- SWD or JTAG Debug
- SWD/JTAG code security
- Embedded Trace Module (ETM) for instruction tracing
- Memory Protection Unit (MPU)
- Nested Vectored Interrupt Controller (NVIC) with 29 user interrupts and 8 levels of priority
- Floating Point Unit (FPU)
- Wakeup Interrupt Controller (WIC)
- 24-bit SysTick Count-down Timer
- Hardware Multiply and Divide Instructions

13.2 System Block Diagram

Figure 18 Arm Cortex-M4F MCU System Block Diagram

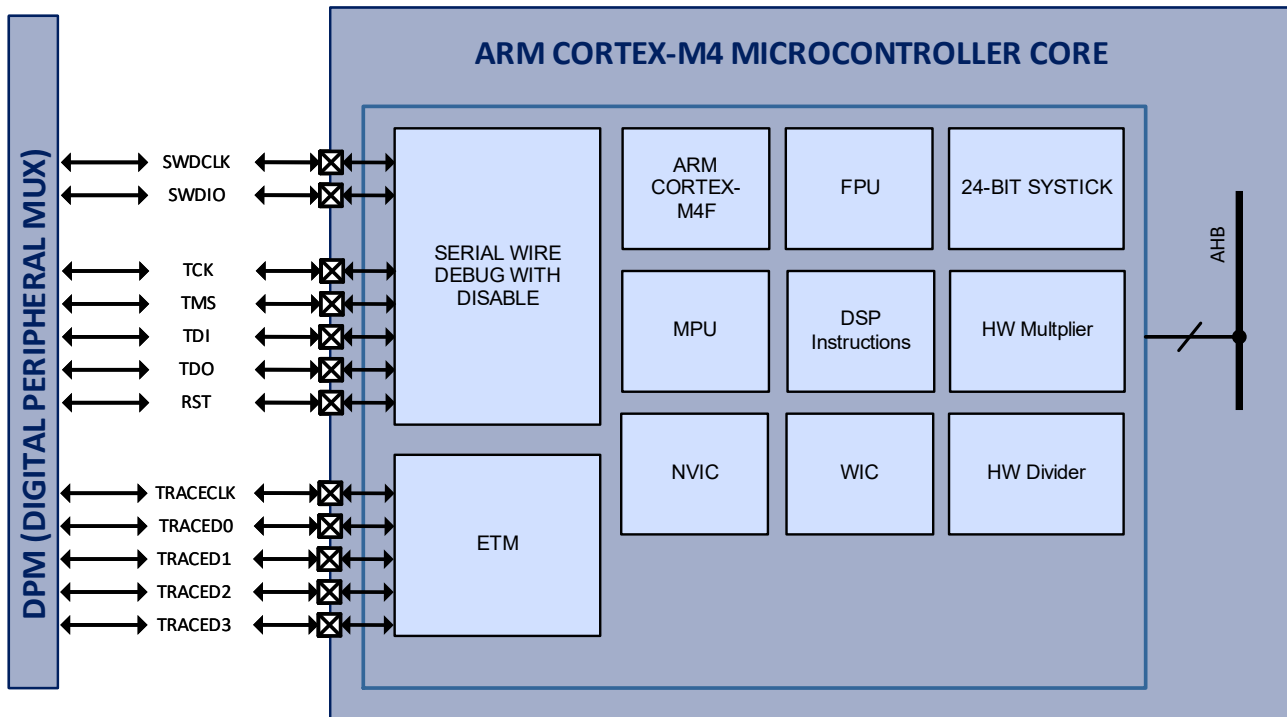

13.3 Functional Description

The Arm® Cortex®-M4F microcontroller core is configured for little endian operation and includes hardware support for multiplication and division, DSP instructions as well as an IEEE754 single-precision Floating Point Unit (FPU).

The MCU also contains an 8-region Memory Protection Unit (MPU), as well as a Nested Vector Interrupt Controller (NVIC) that supports 29 user interrupts with 8 levels of priority. There is a 24-bit SysTick count-down timer.

The Arm® Cortex®-M4F supports sleep and deep sleep modes for low power operation. In sleep mode, the Arm® Cortex®-M4F is disabled. In deep sleep mode, the MCU as well as many peripherals are disabled. The Wakeup Interrupt Controller (WIC) can wake up the MCU when in deep sleep mode by using any GPIO interrupt, the Real-Time Clock (RTC) or Windowed Watchdog Timer (WWDT). The PAC55XX also supports clock gating to reduce power during deep sleep operation.

The debugger supports 4 breakpoint and 2 watch-point unit comparators using the SWD or JTAG protocols. The debug serial interfaces may be disabled to prevent memory access to the firmware during customer production.

For more information on the detailed operation of the Microcontroller Core in the PAC55XX, see the PAC55XX Family User Guide.

High Pin-Count 70V Motor Controller and Driver for BLDC Motors

13.4 Application Typical Current Consumption

The MCU clock configuration and peripheral configuration have a large influence on the amount of load that the power supplies in the PAC55XX will have.

The table below shows a number of popular configurations and what the typical power consumption will be on the VSYS and VCORE power supplies in the PAC55XX.

Table 28 PAC55XX Application Typical Current Consumption

CLOCK CONFIGURATION	MCU PERIPHERALS	MCU STATE	IVSYS	IVCORE	IVCC33
CLKREF = 4MHz PLL Disabled ACLK=HCLK=PCLK=SCLK=MCLK = 16MHz ROSCCLK Enabled FRCLK MUX = ROSCCLK	All peripherals disabled	Halted	9.5mA	2.3mA	n/a
CLKREF = 4MHz PLLCLK = 30MHz ACLK=HCLK=PCLK=SCLK= 16MHz MCLK = 30MHz ROSCCLK Enabled FRCLK MUX = CLKREF	All peripherals disabled	Halted	10.5mA	3.5mA	n/a
CLKREF = 4MHz PLLCLK = 150MHz ACLK=HCLK=PCLK=SCLK= 150MHz MCLK = 30MHz ROSCCLK Enabled FRCLK MUX = CLKREF	All peripherals disabled	Halted	20mA	13.5mA	n/a
CLKREF = 4MHz PLLCLK = 300MHz ACLK=HCLK=PCLK=SCLK= 150MHz MCLK = 30MHz ROSCCLK Enabled FRCLK MUX = CLKREF	All peripherals disabled	Halted	22mA	15mA	n/a
CLKREF = 4MHz PLLCLK = 300MHz ACLK=HCLK=PCLK=SCLK= 150MHz MCLK = 30MHz ROSCCLK Enabled FRCLK MUX = CLKREF ADCCLK = 40MHz	ADC enabled (repeated conversions)	Halted	36mA	16mA	13.5mA
CLKREF = 4MHz	All peripherals disabled	CPU Executes	8.5mA	2.2mA	n/a



PAC5524

High Pin-Count 70V Motor Controller and Driver for BLDC Motors

PLLCLK = 300MHz ACLK=HCLK=PCLK=SCLK= 150MHz MCLK = 30MHz ROSCCLK Enabled FRCLK MUX = CLKREF		instructions from FLASH			
CLKREF = 4MHz PLLCLK = 300MHz ACLK=HCLK=PCLK=SCLK= 150MHz MCLK = 30MHz ROSCCLK Enabled FRCLK MUX = CLKREF	Timer A enabled; TAPWM[7:0] enabled; Fs = 100kHz; 50% duty cycle	Halted	22mA	15mA	n/a

13.5 Electrical Characteristics

The Electrical Characteristics for the System and Clock Control module are shown below.

Table 29 System and Clock Control Electrical Characteristics

Symbol	Parameter	Conditions	Min.	Typ.	Max.	Units
f_{HCLK}	MCU Clock				50	MHz
$I_{Q;V_{CORE}}$	V_{CORE} quiescent current	Arm® Cortex®-M4F Sleep/Deep Sleep Modes			2	mA
		PAC5524 Hibernate Mode			0	mA
$I_{Q;V_{SYS}}$	V_{SYS} quiescent current	Arm® Cortex®-M4F Sleep/Deep Sleep Modes			8	mA
		PAC5524 Hibernate Mode			15	μA
$I_{Q;V_{CCIO}}$	VCCIO quiescent current	Arm® Cortex®-M4F Sleep/Deep Sleep Modes			0.15	mA
		PAC5524 Hibernate Mode			0	mA
$I_{Q;V_{CC33}}$	VCC33 quiescent current	Arm® Cortex®-M4F Sleep/Deep Sleep Modes			0.4	mA
		PAC5524 Hibernate Mode			0	mA

14 IO Controller

14.1 Features

- 3.3V Input/Output, 4.6V input tolerant
- Push-Pull Output, Open-Drain Output or High-Impedance Input for each IO
- Configurable Pull-up and Pull-down for each IO (60k)
- Configurable Drive Strength for each IO (up to 24mA)
- Analog Input for some IOs
- Edge-sensitive or level-sensitive interrupts
- Rising edge, falling edge or both edge interrupts
- Peripheral MUX allowing up to 8 peripheral selections for each IO
- Configurable De-bouncing Circuit for each IO

14.2 System Block Diagram

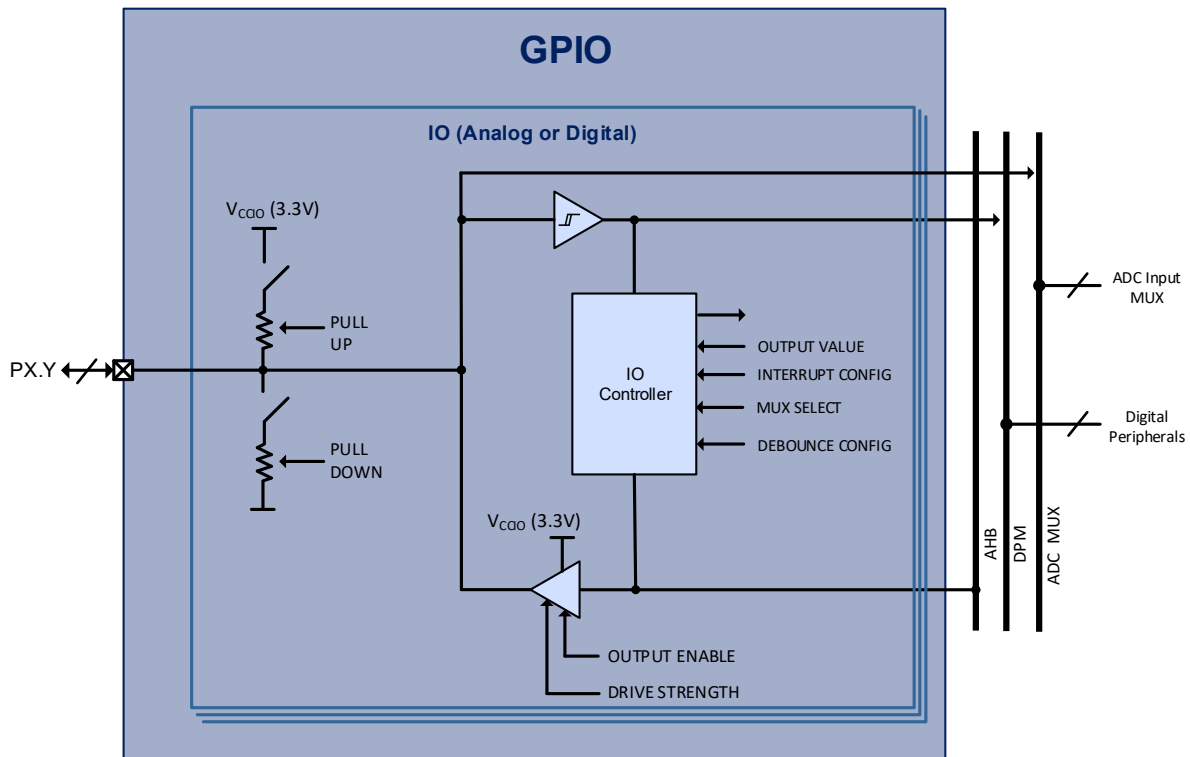

Figure 19 IO Controller System Block Diagram

14.3 Functional Description

14.3.1 IO Controller

The PAC55XX IO cells can be used for digital input/output and analog input for the ADC. All IOs are supplied by the V_{CCIO} (3.3V) power supply.

Each IO can be configured for digital push-pull output, open-drain output or high-impedance input. Each IO also has a configurable 60k weak pull-up or weak pull-down that can be enabled.

NOTE: Configuring both pull-up and pull-down at the same time may cause device damage and should be avoided.

Each IO has a configurable de-bouncing filter that can be enabled or disabled, to help filter out noise.

All IO have interrupt capability. Each pin can be configured for either level or edge sensitive interrupts, and can select between rising edge, falling edge and both edges for interrupts. Each pin has a separate interrupt enable and interrupt flag.

Some of the IO on the PAC5524 can be configured as an analog input to the ADC.

14.3.2 GPIO Current Injection

Under normal operation, there should not be current injected into the GPIOs on the device due to the GPIO voltage below ground or above the GPIO supply (V_{CCIO}). Current will be injected into the GPIO when the GPIO pin voltage is less than $-0.3V$ or when greater than $GPIO\ supply + 0.3V$.

In order provide a robust solution when this situation occurs, the PAC52XX family of products allows a small amount of injected current into the GPIO pins, to avoid excessive leakage or device damage.

For information on the GPIO current injection thresholds, see the absolute maximum parameters for this device.

Sustained operation with the GPIO pin voltage greater than the GPIO supply or when the GPIO pin voltage is less than $-0.3V$ may result in reduced lifetime of the device. GPIO current injection should only be a temporary condition.



PAC5524

High Pin-Count 70V Motor Controller and Driver for BLDC Motors

14.3.3 Peripheral MUX

The Peripheral MUX (DPM) allows the IO controller to select one of up to four peripheral functions for each IO pin. Note that if the pin is configured for analog input, the peripheral MUX is bypassed.

The Peripheral MUX for the PAC5524 is shown below.

Table 30 Peripheral MUX settings

PIN	PERIPHERAL MUX SETTINGS								ADC CH
	S0	S1	S2	S3	S4	S5	S6	S7	
PC0	GPIOC0	TBPWM0	TCPWM0	TBQEPIDX	USBMOSI	USCSCLK	CANRXD	I2CSCL	
PC1	GPIOC1	TBPWM1	TCPWM1	TBQEPPHA	USBMISO	USCSS	CANTXD	I2CSDA	
PC2	GPIOC2	TBPWM2	TCPWM2	TBQEPPHB	USBSCLK	USCMOSI		EMUXD	
PC3	GPIOC3	TBPWM3	TCPWM3		USBSS	USCMISO		EMUXC	
PC4	GPIOC4	TBPWM4	TCPWM4	TCQEPIDX	USBMOSI	USCSCLK	CANRXD	I2CSDL	
PC5	GPIOC5	TBPWM5	TCPWM5	TCQEPPHA	USBMISO	USCSS	CANTXD	I2CSDA	
PC6	GPIOC6	TBPWM6	TCPWM6	TCQEPPHB	USBSCLK	USCMOSI		EMUXD	
PC7	GPIOC7	TBPWM7	TCPWM7		USBSS	USCMISO	FRCLK	EMUXC	
PD0	GPIOD0	TBPWM0	TCPWM0	TDQEPIDX		USCSCLK	CANTXD	EMUXD	AD4
PD1	GPIOD1	TBPWM1	TCPWM1	TDQEPPHA		USCSS	CANRXD	EMUXC	AD3
PD2	GPIOD2	TBPWM2	TCPWM2	TDQEPPHB		USCMOSI			AD2
PD3	GPIOD3	TBPWM3	TCPWM3			USCMISO	FRCLK	TRACED3	AD1
PD4	GPIOD4	TBPWM4	TCPWM4	TDQEPIDX	TBQEPIDX	USDCLK	TRACED3	USDMSI	
PD5	GPIOD5	TBPWM5	TCPWM5	TDQEPPHA	TBQEPPHA	USDSS	CANRXD	USDMSO	
PD6	GPIOD6	TBPWM6	TCPWM6	TDQEPPHB	TBQEPPHB	USDMSI	CANTXD	I2CSDA	
PE0	GPIOE0	TCPWM4	TDPWM0	TAQEPIDX	TBQEPIDX	USCLK	I2CSCL	EMUXC	
PE1	GPIOE1	TCPWM5	TDPWM1	TAQEPPHA	TBQEPPHA	USCSS	I2CSDA	EMUXD	
PE2	GPIOE2	TCPWM6	TDPWM2	TAQEPPHB	TBQEPPHB	USCMOSI	CANRXD	EXTCLK	
PE3	GPIOE3	TCPWM7	TDPWM3	FRCLK		USCMISO	CANTXD		
PF0	GPIOF0	TCPWM0	TDPWM0	TCK/SWDCL	TBQEPIDX	USBSCLK	TRACED2	TRACECLK	
PF1	GPIOF1	TCPWM1	TDPWM1	TMS/SWDIO	TBQEPPHA	USBSS	TRACED1	TRACED0	
PF2	GPIOF2	TCPWM2	TDPWM2	TDI	TBQEPPHB	USBMOSI	TRACED0	TRACED1	
PF3	GPIOF3	TCPWM3	TDPWM3	TDO	FRCLK	USBMISO	TRACECLK	TRACED2	
PF4	GPIOF4	TCPWM4	TDPWM4		TCQEPIDX	USDCLK	TRACED3	EMUXC	AD4
PF5	GPIOF5	TCPWM5	TDPWM5		TCQEPPHA	USDSS		EMUXD	AD5
PF6	GPIOF6	TCPWM6	TDPWM6		TCQEPPHB	USDMSI	CANRXD	I2CSCL	AD6
PF7	GPIOF7	TCPWM7	TDPWM7			USDMSO	CANTXD	I2CSDA	AD7
PG0	GPIOG0	TCPWM0	TDPWM0	EMUXC		USDCLK	TRACECLK	TCQEPIDX	
PG1	GPIOG1	TCPWM1	TDPWM1	EMUXD		USDSS	TRACED0	TCQEPPHA	
PG2	GPIOG2	TCPWM2	TDPWM2	FRCLK		USDMSI	TRACED1	TCQEPPHB	
PG3	GPIOG3	TCPWM3	TDPWM3			USDMSO	TRACED2		

High Pin-Count 70V Motor Controller and Driver for BLDC Motors

14.4 Electrical Characteristics

The Electrical Characteristics for the IO Controller are shown below.

Table 31 IO Controller Electrical Characteristics

Symbol	Parameter	Conditions	Min.	Typ.	Max.	Units
V_{IH}	High-level input voltage		2.1			V
V_{IL}	Low-level input voltage				0.825	V
I_{OL}	Low-level output sink current (Limited by $I_{V_{SYS}}$ and $I_{V_{CCIO}}$)	$V_{OL} = 0.4V$	DS = 6mA	6		mA
			DS = 8mA	8		
			DS = 11mA	11		
			DS = 14mA	14		
			DS = 17mA	17		
			DS = 20mA	20		
			DS = 22mA	22		
			DS = 25mA	25		
I_{OH}	High-level output source current (Limited by $I_{V_{SYS}}$ and $I_{V_{CCIO}}$)	$V_{OH} = 2.4V$	DS = 6mA		-6	mA
			DS = 8mA		-8	
			DS = 11mA		-11	
			DS = 14mA		-14	
			DS = 17mA		-17	
			DS = 20mA		-20	
			DS = 22mA		-22	
			DS = 25mA		-25	
I_{IL}	Input leakage current		-2		0.95	μA
R_{PU}	Weak pull-up resistance	When pull-up enabled	45	60	100	k Ω
R_{PD}	Weak pull-down resistance	When pull-down enabled	45	60	115	k Ω
$I_{INJ;GPIO}$	GPIO pin current injection	$V_{GPIO} < -0.3V$ or $V_{GPIO} > V_{CCIO} + 0.3V$	-15		15	mA
$\Sigma I_{INJ;GPIO}$	Sum of all GPIO pin current injection	$V_{GPIO} < -0.3V$ or $V_{GPIO} > V_{CCIO} + 0.3V$	-40		40	mA

$T_A = -40^\circ C$ to $125^\circ C$ unless otherwise specified

15 Serial Interface

15.1 Features

- USART (UART or SPI master/slave)
- I2C master/slave
- CAN 2.0B controller

15.2 System Block Diagram

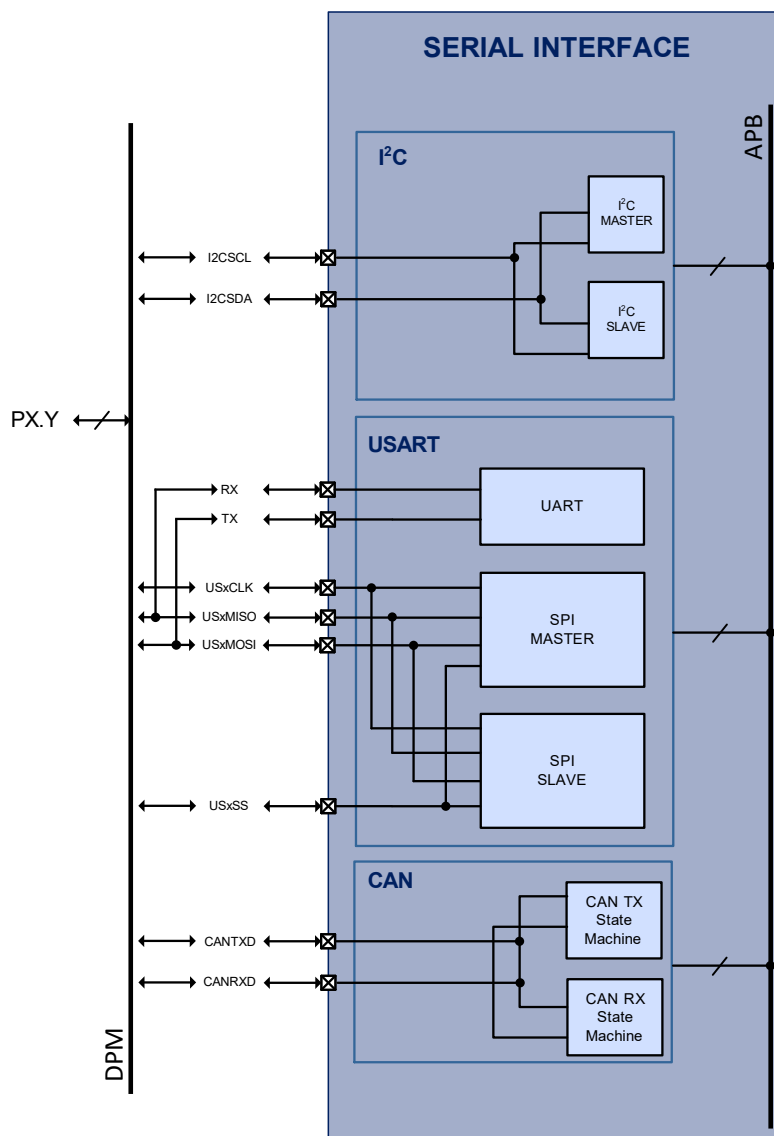

Figure 20 Serial Interfaces System Block Diagram

15.3 Functional Description

The PAC55XX has three types of serial interfaces: I²C, USART and CAN. The PAC55XX has one I²C controller, one CAN controller and up to 3 USARTs.

15.4 I²C Controller

The PAC55XX contains one I²C controller. This is a configurable APB peripheral and the clock input is PCLK. This peripheral has an input clock divider that can be used to generate various master clock frequencies. The I²C controller can support various modes of operation:

- I²C master operation
 - Standard (100kHz), full-speed (400kHz), fast (1MHz) or high-speed modes (3.4MHz)
 - Single and multi-master
 - Synchronization (multi-master)
 - Arbitration (multi-master)
 - 7-bit or 10-bit slave addressing
- I²C slave operation
 - Standard (100kHz), full-speed (400kHz), fast (1MHz) or high-speed modes (3.4MHz)
 - Clock stretching
 - 7-bit or 10-bit slave addressing

The I²C peripheral may operate either by polling or can be configured to be interrupt driven for both receive and transmit operations.

15.5 USART

The PAC55XX contains up to 2 Universal Synchronous Receive Transmit (USART) peripherals. Each USART is a configurable APB bus client and input clock is PCLK. These peripherals have a configurable clock divider that can be used to produce various frequencies for the UART or SPI master peripheral.

The number of these peripherals depends on the peripheral MUX configuration. See the IO Controller section on information on how to configure the peripheral MUX with the USART peripheral.

The USART peripheral supports two main modes: SPI mode and UART mode.

15.5.1 USART SPI Mode

- Master or slave mode operation
- 8-bit, 16-bit or 32-bit word transfers
- Configurable clock polarity (active high or active low)
- Configurable data phase (setup/sample or sample/setup)
- Interrupts and status flags for RX and TX operations
- Support for up to 25MHz SPI clock

15.5.2 USART UART Mode

- 8-bit data
- Programmable data bit rate



PAC5524

High Pin-Count 70V Motor Controller and Driver for BLDC Motors

- Maximum baud rate of 1Mbaud
- RX and TX FIFOs
- Configurable stop bits (1 or 2)
- Configurable parity: even, odd, none
 - Mark/space support for 9-bit addressing protocols
- Interrupt and status flags for RX and TX operations

15.6 CAN

The PAC55XX contains one Controller Area Network (CAN) peripheral. The CAN peripheral is a configurable APB bus client and input clock is PCLK. This peripheral has a configurable clock divider that can be used to produce various frequencies for the CAN peripheral.

- CAN 2.0B support
- 1Mb/s data rate
- 64-byte receive FIFO
- 16-byte transmit buffer
- Standard and extended frame support
- Arbitration
- Overload frame generated on FIFO overflow
- Normal and Listen Only modes supported
- Interrupt and status flags for RX and TX operations

15.7 Dynamic Characteristics

The Dynamic Characteristics for the Serial Interfaces on the PAC5524 are shown below.

15.7.1 Serial Interface

Table 32 Serial Interface Dynamic Characteristics

Symbol	Parameter	Conditions	Min.	Typ.	Max.	Units
I2C						
f_{I2CCLK}	I ² C input clock frequency	Standard mode (100kHz)	2.8			MHz
		Full-speed mode (400kHz)	2.8			MHz
		Fast mode (1MHz)	6.14			MHz
		High-speed mode (3.4MHz)	20.88			MHz
USART (UART mode)						
$f_{USARTCLK}$	USART input clock frequency				$f_{PCLK}/16$	MHz
$f_{UARTBAUD}$	UART baud rate	$f_{USARTCLK} = 7.1825\text{MHz}$			1	Mbps
USART (SPI mode)						
f_{SPICLK}	USART input clock frequency	Master mode			50	MHz
		Slave mode			50	MHz
$f_{USARTSPICLK}$	USART SPI clock frequency	Master mode			25	MHz
		Slave mode			25	MHz
CAN						
f_{CANCLK}	CAN input clock frequency				50	MHz
f_{CANTX}	CAN transmit clock frequency				1	Mbps
f_{CANRX}	CAN receive clock frequency				1	Mbps

High Pin-Count 70V Motor Controller and Driver for BLDC Motors

15.7.2 I2C Dynamic Characteristics

Table 33 I2C Dynamic Characteristics

Symbol	Parameter	Conditions	Min.	Typ.	Max.	Units
f_{SCL}	SCL clock frequency	Standard mode	0		100	kHz
		Full-speed mode	0		400	kHz
		Fast mode	0		1	MHz
t_{LOW}	SCL clock low	Standard mode	4.7			μ s
		Full-speed mode	1.3			μ s
		Fast mode	0.5			μ s
t_{HIGH}	SCL clock high	Standard mode	4.0			μ s
		Full-speed mode	0.6			μ s
		Fast mode	0.26			μ s
$t_{HD;STA}$	Hold time for a repeated START condition	Standard mode	4.0			μ s
		Full-speed mode	0.6			μ s
		Fast mode	0.26			μ s
$t_{SU;STA}$	Set-up time for a repeated START condition	Standard mode	4.7			μ s
		Full-speed mode	0.6			μ s
		Fast mode	0.26			μ s
$t_{HD;DAT}$	Data hold time	Standard mode	0		3.45	μ s
		Full-speed mode	0		0.9	μ s
		Fast mode	0			μ s
$t_{SU;DAT}$	Data setup time	Standard mode	250			ns
		Full-speed mode	100			ns
		Fast mode	50			ns
$t_{SU;STO}$	Set-up time for STOP condition	Standard mode	4.0			μ s
		Full-speed mode	0.6			μ s
		Fast mode	0.26			μ s
t_{BUF}	Bus free time between a STOP and START condition	Standard mode	4.7			μ s
		Full-speed mode	1.3			μ s
		Fast mode	0.5			μ s
t_r	Rise time for SDA and SCL	Standard mode			1000	ns
		Full-speed mode	20		300	ns
		Fast mode			120	ns
t_f	Fall time for SDA and SCL	Standard mode			300	ns
		Full-speed mode			300	ns
		Fast mode			120	ns
C_b	Capacitive load for each bus line	Standard mode, full-speed mode			400	pF
		Fast mode			550	pF

15.7.3 I2C Timing Diagram

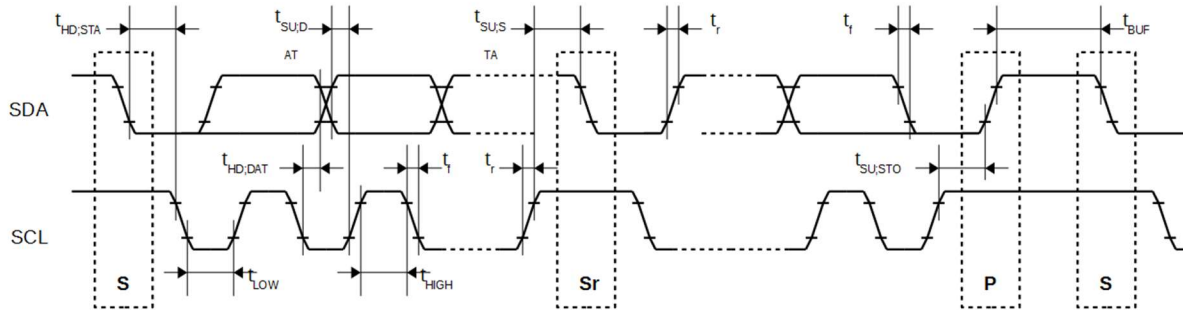

Figure 21 I2C Timing Diagram

16 PWM Timers

16.1 Features

- Base timer features:
 - Configurable input clock source: PCLK or ACLK
 - Up to 300MHz input clock
 - 3-bit Input clock divider
 - Timer counting modes
 - Up, up/down and asymmetric
 - Timer latch modes
 - Latch when counter = 0
 - Latch when counter = period
 - Latch when CCR value written
 - Latch all CCR values at same time
 - Base timer interrupts
 - Single shot or auto-reload
- CCR/PWM Timer
 - PWM output or capture input
 - CCR interrupt enable
 - CCR interrupt skips
 - SW force CCR interrupt
 - CCR interrupt type
 - Rising, falling or both
 - CCR compare latch modes
 - Latch when counter = 0
 - Latch when counter = period
 - Latch immediate
 - CCR capture latch modes
 - Latch on rising edge
 - Latch on falling edge
 - Latch on both rising and falling edges
 - Invert CCR output
 - CCR phase delay for phase shifted drive topologies
 - ADC trigger outputs
 - PWM rising edge or falling edge
- Dead-time Generators (DTG)
 - DTG enabled
 - 12-bit rising edge delay



PAC5524

High Pin-Count 70V Motor Controller and Driver for BLDC Motors

- 12-bit falling edge delay
- QEP Decoder
 - QEP encoder enabled
 - Direction status
 - Configurable Interrupts:
 - Phase A rising edge
 - Phase B rising edge
 - Index event
 - Counter wrap
 - 4 different counting modes for best resolution, range and speed performance

16.2 System Block Diagram

Figure 22 PWM Timers System Block Diagram

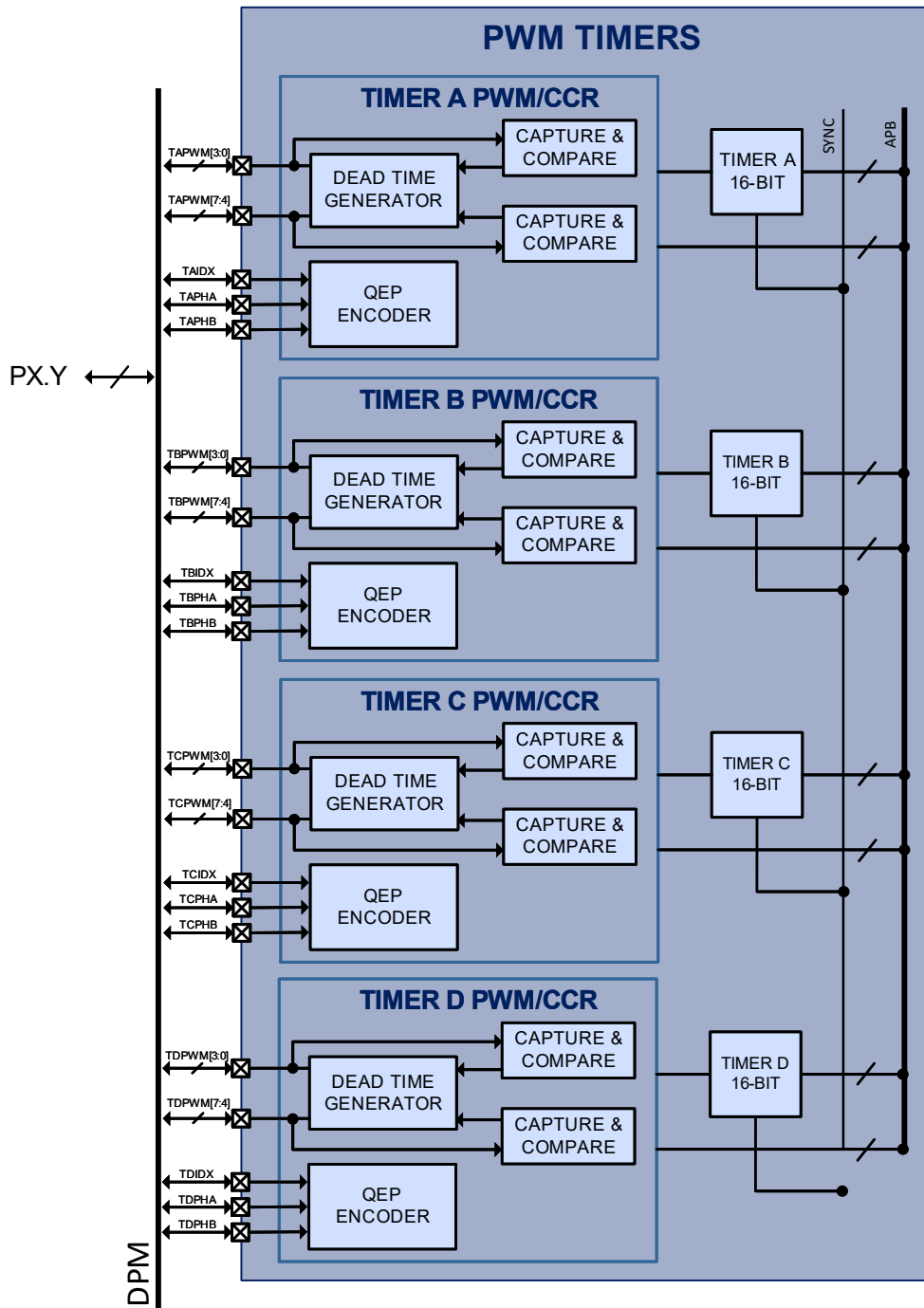

16.3 Functional Description

The PAC5524 contains four 16-bit timer units that may be used for PWM output and capture input. Each timer has a 16-bit time-base that may configure the counting style to up, up/down and up/down asymmetric modes. These modes can be used to support different drive topologies such as 120° trapezoidal and 180° sinusoidal.

Each base timer block may be clocked by either PCLK or ACLK. Configuring the timer to clock using ACLK allows higher PWM edge resolution by offering a clock that is up to 2X higher than the system clock. The base timer supports interrupts as well as single shot or auto-reload modes for maximum flexibility.

Each base timer has up to 8 CCR units that may be used for PWM output or capture input. When configured for PWM output, the user may configure a delay in order to support phase delay drive topologies. The CCR output may also be inverted in order to support full-bridge topologies.

The user may configure each CCR output rising or falling edge to interrupt the DTSE to begin a sequence of conversions.

17 General Purpose Timers

17.1 Features

- SOC Bus Watchdog Timer
- Hibernate Wake-up Timer
- Real-Time Clock with Calendar and Alarm
- Windowed Watchdog Timer (WWDT)
- 24-Bit General-purpose Timers

17.2 System Block Diagram

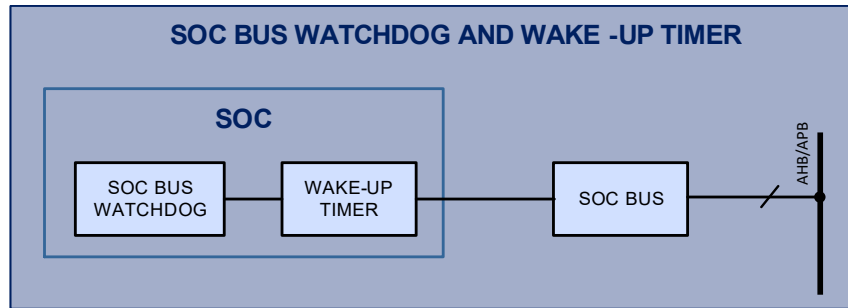

Figure 23 SOC and WWDT System Block Diagrams

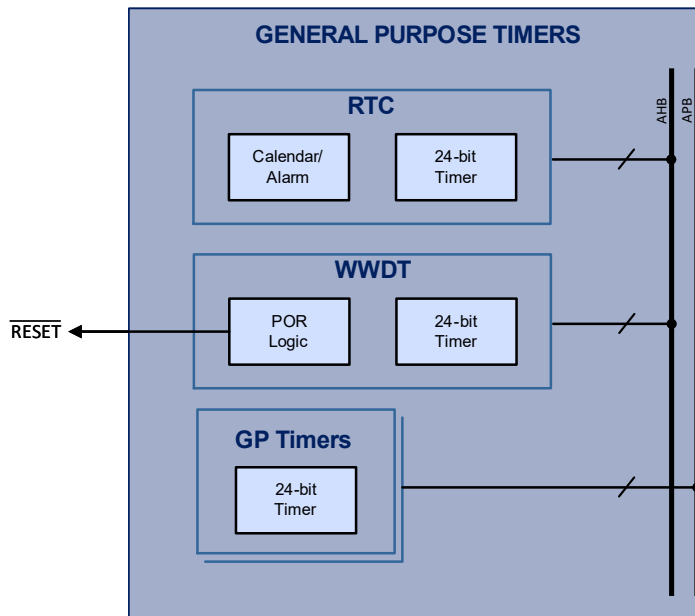

Figure 24 General-Purpose Timers System Block Diagrams

17.3 Functional Description

17.3.1 SOC Bus Watchdog Timer

The SOC Bus Watchdog Timer is used to monitor internal SOC Bus communication. It will trigger a device reset if there is no SOC Bus communication to the AFE for 4s or 8s.

17.3.2 Wake-up Timer

The wake-up timer can be used for very low power hibernate and sleep modes to wake up the micro controller periodically. It can be configured to be 125ms, 250ms, 500ms, 1s, 2s, 4, or 8s.

17.3.3 Real-time Clock with Calendar (RTC)

The 24-bit real-time clock with calendar (RTC) is an AHB bus client and may also be used to measure long time periods and periodic wake up from sleep mode.

The RTC uses FRCLK as its clock source and has a divider that can be configured up to a /65536 input clock divider. In order to count accurately, the input clock divider must be configured to generate a 1MHz clock to the RTC.

The RTC counts the time (seconds, minutes, hours, days) since enabled. It also allows the user to set a calendar date to set an alarm function that can be configured to generate an interrupt to the NVIC when it counts to that value.

17.3.4 Windowed Watchdog Timer (WWDT)

The 24-bit windowed watchdog timer (WWDT) is an AHB bus client and can be used for long time period measurements or periodic wake up from sleep mode. Its primary use is to reset the system via a POR if it is not reset at a certain periodic interval.

The WWDT can be configured to use FRCLK or ROSCCLK as its clock source and has a divider that be configured up to a /65536 input clock divider.

The WWDT can be configured to allow only a small window when it is valid to reset the timer, to maximize application security and catch any stray code operating on the MCU.

The WWDT may be configured to enable an interrupt for the MCU, and the timer can be disabled when unused to save energy for low power operations.

17.3.5 GP Timer (GPT)

The PAC55XX contains two General Purpose (GP) Timers.

These timers are 24-bit timers and are both APB bus clients. These count-down timers use PCLK as their input clock and have a configurable divider of up to /32768. Each of the GPT can be configured to interrupt the MCU when they count down to 0.

18 CRC

18.1 Features

- 8-bit or 16-bit CRC
- User may select the polynomial through configuration:
 - CCITT CRC-16
 - IBM/ANSI CRC-16
 - Dallas/Maxim CRC-8
- Input data width: 8b or 32b
- Reflect input
- Reflect output
- Specify seed value

18.2 System Block Diagram

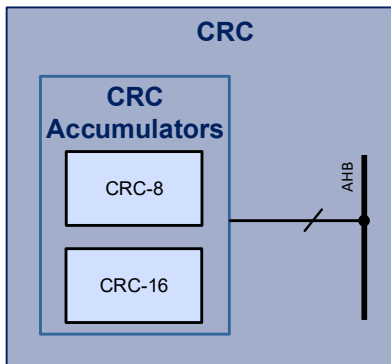

Figure 25 CRC System Block Diagram

18.3 Functional Description

The CRC peripheral can perform CRC calculation on data through registers from the MCU to accelerate the calculation or validation of a CRC for communications protocols or data integrity checks.

The CRC peripheral allows the calculation of both CRC-8 and CRC-16 on data. The CRC peripheral also allows the user to specify a seed value, select the data input to be 8b or 32b and to reflect the final output for firmware efficiency.

19 Application Block Diagram

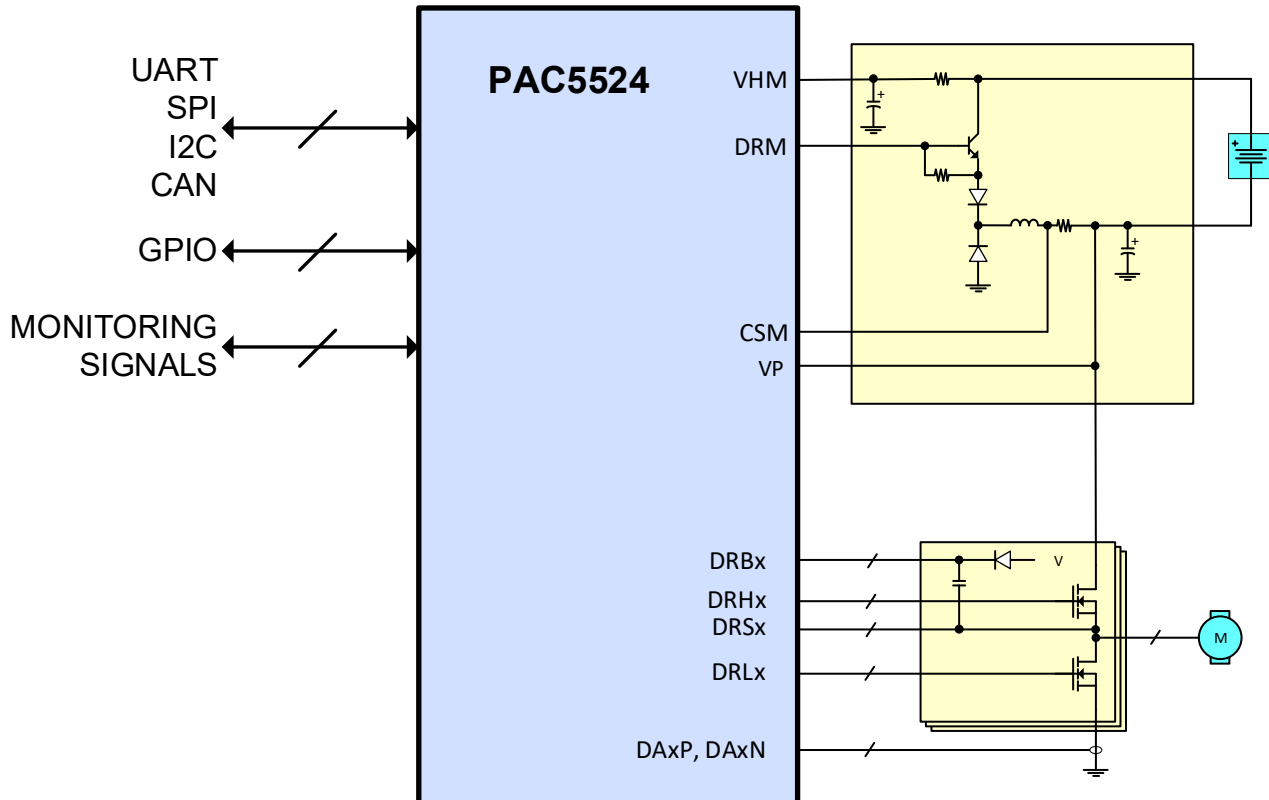

Figure 26 PAC5524 Application Block Diagram



PAC5524
High Pin-Count 70V Motor Controller and Driver for BLDC Motors

20 Thermal Characteristics

Table 34 Thermal Characteristics

SYMBOL	PARAMETER	VALUE	UNIT
T_A	Operating ambient temperature range	-40 to 105	°C
T_J	Operating junction temperature range	-40 to 125	°C
T_{STG}	Storage temperature range	-55 to 150	°C
	Lead temperature (Soldering, 10 seconds)	300	°C
Θ_{JC}	Junction-to-case thermal resistance	2.897	°C/W
Θ_{JA}	Junction-to-ambient thermal resistance	23.36	°C/W

21 Pin Configuration and Description

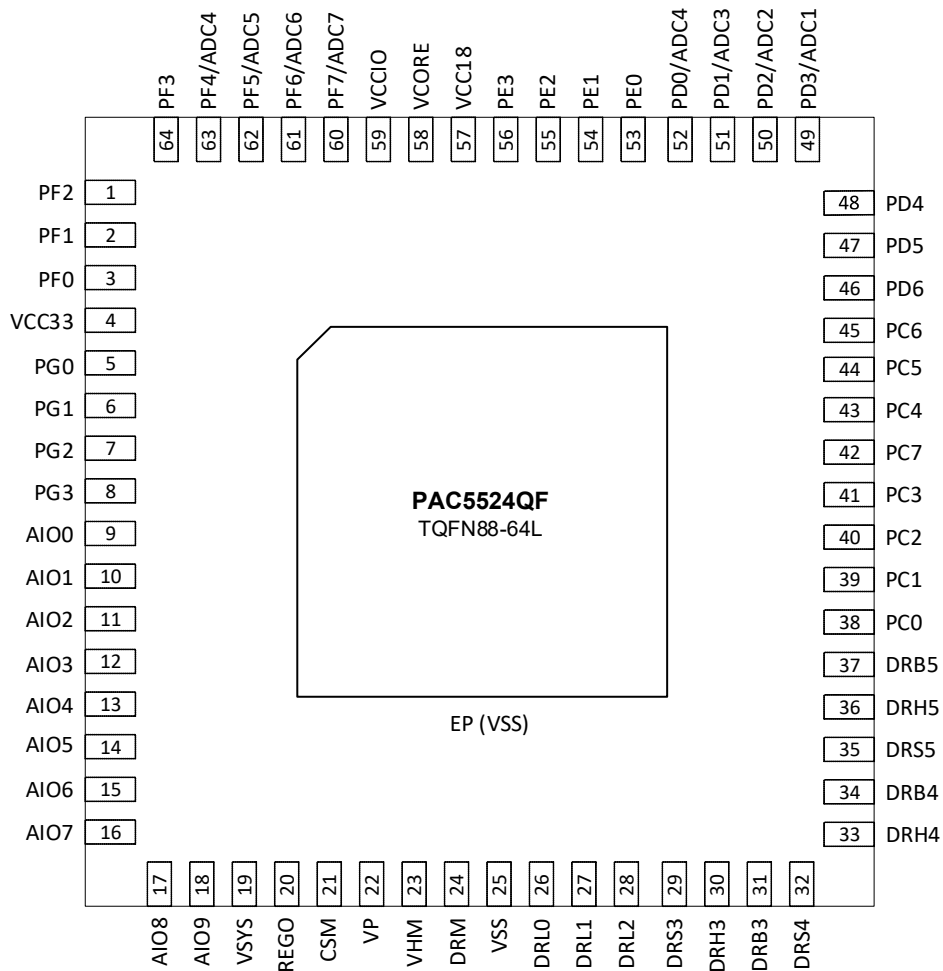

Top View

High Pin-Count 70V Motor Controller and Driver for BLDC Motors

21.1 MPPM and System Pin Descriptions

Pin Number	Pin Name	Description
4	VCC33	Internally generated 3.3V power supply. Connect to a 2.2 μ F or higher value ceramic capacitor from V _{CC33} to V _{SSA} .
19	VSYS	5V System power supply. Connect to a 6.8 μ F (20%) or higher ceramic capacitor from V _{SYS} to V _{SS} .
20	REGO	System regulator output. Connect to V _{SYS} directly or through an external power-dissipating resistor.
21	CSM	Switching supply current sense input. Connect to the positive side of the current sense resistor.
22	VP	Main power supply. Provides power to the power drivers as well as voltage feedback path for the switching supply. Connect a properly sized supply bypass capacitor in parallel with a 0.1 μ F ceramic capacitor from V _P to V _{SS} for voltage loop stabilization. This pin requires good capacitive bypassing to V _{SS} , so the ceramic capacitor must be connected with a shorter than 10mm trace from the pin.
23	VHM	Switching supply controller supply input. Connect a 1 μ F or higher value ceramic capacitor, or a 0.1 μ F ceramic capacitor in parallel with a 10 μ F or higher electrolytic capacitor from V _{HM} to V _{SSP} . This pin requires good capacitive bypassing to V _{SSP} , so the ceramic capacitor must be connected with a shorter than 10mm trace from the pin.
24	DRM	Switching supply driver output. Connect to the base or gate of the external power NPN or n-channel MOSFET. See User Guide and application notes.
25	VSS	Ground.
57	VCC18	Internally generated 1.8V power supply. Connect a 2.2 μ F or higher value ceramic capacitor from V _{CC18} to V _{SSA} .
58	VCORE	Internally generated 1.2V core power supply. Connect a 2.2 μ F or higher value ceramic capacitor from V _{CORE} to V _{SSA} .
59	VCCIO	Internally generated digital I/O 3.3V power supply. Connect a 4.7 μ F or higher value ceramic capacitor from V _{CCIO} to V _{SSA} .
EP	EP (VSS)	Exposed pad. Must be connected to V _{SS} in a star ground configuration. Connect to a large PCB copper area for power dissipation heat sinking.
4	VCC33	Internally generated 3.3V power supply. Connect to a 2.2 μ F or higher value ceramic capacitor from V _{CC33} to V _{SSA} .
19	VSYS	5V System power supply. Connect to a 6.8 μ F (20%) or higher ceramic capacitor from V _{SYS} to V _{SS} .
20	REGO	System regulator output. Connect to V _{SYS} directly or through an external power-dissipating resistor.
21	CSM	Switching supply current sense input. Connect to the positive side of the current sense resistor.
22	VP	Main power supply. Provides power to the power drivers as well as voltage feedback path for the switching supply. Connect a properly sized supply bypass capacitor in parallel with a 0.1 μ F ceramic capacitor from V _P to V _{SS} for voltage loop stabilization. This pin requires good capacitive bypassing to V _{SS} , so the ceramic capacitor must be connected with a shorter than 10mm trace from the pin.
23	VHM	Switching supply controller supply input. Connect a 1 μ F or higher value ceramic capacitor, or a 0.1 μ F ceramic capacitor in parallel with a 10 μ F or higher electrolytic capacitor from V _{HM} to V _{SSP} . This pin requires good capacitive bypassing to V _{SSP} , so the ceramic capacitor must be connected with a shorter than 10mm trace from the pin.
24	DRM	Switching supply driver output. Connect to the base or gate of the external power NPN or n-channel MOSFET. See User Guide and application notes.
25	VSS	Ground.
57	VCC18	Internally generated 1.8V power supply. Connect a 2.2 μ F or higher value ceramic capacitor from V _{CC18} to V _{SSA} .
58	VCORE	Internally generated 1.2V core power supply. Connect a 2.2 μ F or higher value ceramic capacitor from V _{CORE} to V _{SSA} .
59	VCCIO	Internally generated digital I/O 3.3V power supply. Connect a 4.7 μ F or higher value ceramic capacitor from V _{CCIO} to V _{SSA} .
EP	EP (VSS)	Exposed pad. Must be connected to V _{SS} in a star ground configuration. Connect to a large PCB copper area for power dissipation heat sinking.



PAC5524

High Pin-Count 70V Motor Controller and Driver for BLDC Motors

21.2 CAFE Pin Descriptions

Pin Number	Pin Name	Function	Type	Description
9	AIO0	AIO0	I/O	Analog front end I/O 0.
		DA0N	Analog	Differential PGA 0 negative input.
10	AIO1	AIO1	I/O	Analog front end I/O 1.
		DA0P	Analog	Differential PGA 0 positive input.
11	AIO2	AIO2	I/O	Analog front end I/O 2.
		DA1N	Analog	Differential PGA 1 negative input.
12	AIO3	AIO3	I/O	Analog front end I/O 3.
		DA1P	Analog	Differential PGA 1 positive input.
13	AIO4	AIO4	I/O	Analog front end I/O 4.
		DA2N	Analog	Differential PGA 2 negative input.
14	AIO5	AIO5	I/O	Analog front end I/O 5.
		DA2P	Analog	Differential PGA 2 positive input.
15	AIO6	AIO6	I/O	Analog front end I/O 6.
		AMP6	Analog	PGA input 6.
		CMP6	Analog	Comparator input 6.
		BUF6	Analog	Buffer output 6.
		PBTN	Analog	Push button input.
16	AIO7	AIO7	I/O	Analog front end I/O 7.
		AMP7	Analog	PGA input 7.
		CMP7	Analog	Comparator input 7.
		PHC7	Analog	Phase comparator input 7.
17	AIO8	AIO8	I/O	Analog front end I/O 8.
		AMP8	Analog	PGA input 8.
		CMP8	Analog	Comparator input 8.
		PHC8	Analog	Phase comparator input 8.
18	AIO9	AIO9	I/O	Analog front end I/O 9.
		AMP9	Analog	PGA input 9.
		CMP9	Analog	Comparator input 9.
		PHC9	Analog	Phase comparator input 9.



PAC5524

High Pin-Count 70V Motor Controller and Driver for BLDC Motors

21.3 ASPD Pin Descriptions

Pin Number	Pin Name	Type	Description
26	DRL0	Analog	Low-side gate driver 0.
27	DRL1	Analog	Low-side gate driver 1.
28	DRL2	Analog	Low-side gate driver 2.
29	DRS3	Analog	High-side gate driver source 3.
30	DRH3	Analog	High-side gate driver 3.
31	DRB3	Analog	High-side gate driver bootstrap 3.
32	DRS4	Analog	High-side gate driver source 4.
33	DRH4	Analog	High-side gate driver 4.
34	DRB4	Analog	High-side gate driver bootstrap 4.
35	DRS5	Analog	High-side gate driver source 5.
36	DRH5	Analog	High-side gate driver 5.
37	DRB5	Analog	High-side gate driver bootstrap 5.



PAC5524

High Pin-Count 70V Motor Controller and Driver for BLDC Motors

21.4 I/O Ports Pin Descriptions

Pin Number	Pin Name	Function	Type	Description
1	PF2	PF2	I/O	I/O port PF2.
2	PF1	PF1	I/O	I/O port PF1.
3	PF0	PF0	I/O	I/O port PF0.
5	PG0	PG0	I/O	I/O port PG0.
6	PG1	PG1	I/O	I/O port PG1.
7	PG2	PG2	I/O	I/O port PG2.
8	PG3	PG3	I/O	I/O port PG3.
38	PC0	PC0	I/O	I/O port PC0.
39	PC1	PC1	I/O	I/O port PC1.
40	PC2	PC2	I/O	I/O port PC2.
41	PC3	PC3	I/O	I/O port PC3.
42	PC7	PC7	I/O	I/O port PC7.
43	PC4	PC4	I/O	I/O port PC4.
44	PC5	PC5	I/O	I/O port PC5.
45	PC6	PC6	I/O	I/O port PC6.
46	PD6	PD6	I/O	I/O port PD6.
47	PD5	PD5	I/O	I/O port PD5.
48	PD4	PD4	I/O	I/O port PD4.
49	PD3	PD3	I/O	I/O port PD3.
		AD1	Analog Input	ADC channel ADC1.
50	PD2	PD2	I/O	I/O port PD2.
		AD2	Analog Input	ADC channel ADC2.
51	PD1	PD1	I/O	I/O port PD1.
		AD3	Analog Input	ADC channel ADC3.
52	PD0	PD0	I/O	I/O port PD0.
		AD4	Analog Input	ADC channel ADC4.
53	PE0	PE0	I/O	I/O port PE0.
54	PE1	PE1	I/O	I/O port PE1.
55	PE2	PE2	I/O	I/O port PE2.
56	PE3	PE3	I/O	I/O port PE3.
60	PF7	PF7	I/O	I/O port PF7.
		AD7	Analog Input	ADC channel ADC7.
61	PF6	PF6	I/O	I/O port PF6.
		AD6	Analog Input	ADC channel ADC6.
62	PF5	PF5	I/O	I/O port PF5.
		AD5	Analog Input	ADC channel ADC5.
63	PF4	PF4	I/O	I/O port PF4.
		AD4	Analog Input	ADC channel ADC4.
64	PF3	PF3	I/O	I/O port PF3.

22 Mechanical Information

Package Marking and Dimensions

Marking: Part number – PAC5524QF

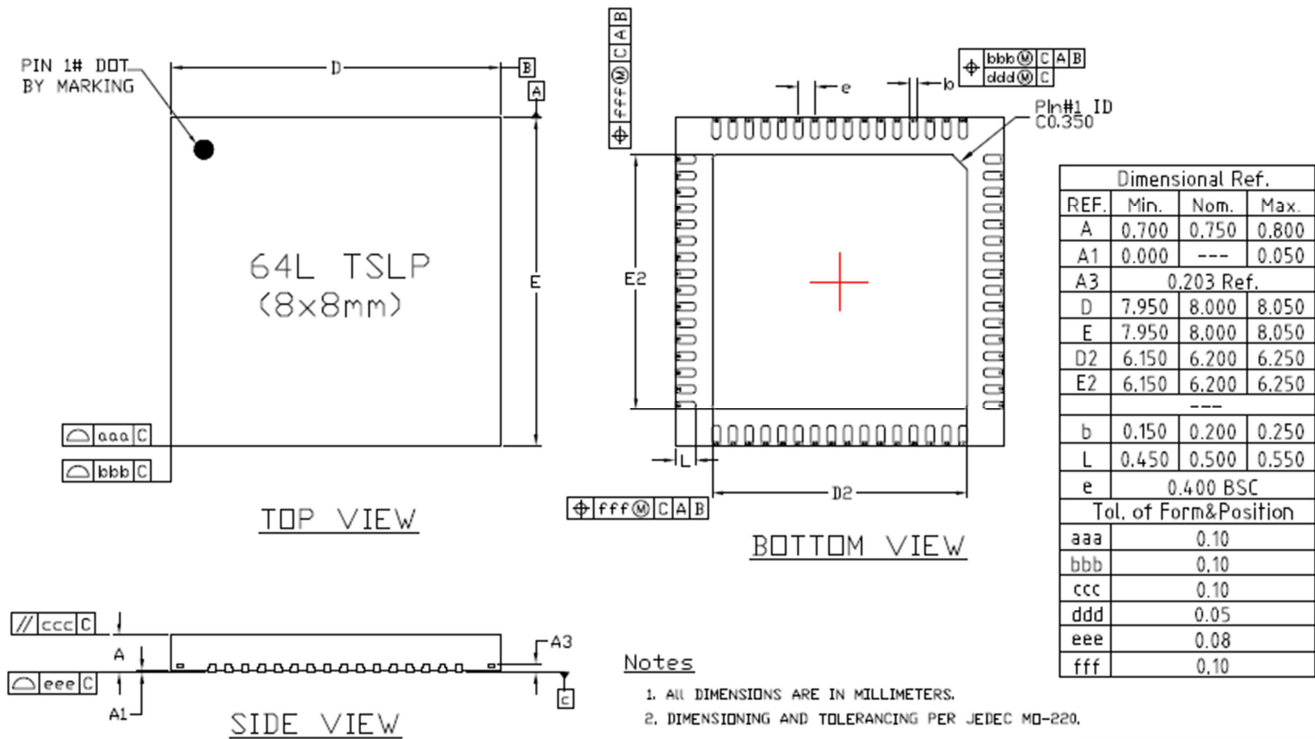

Notes:

1. All dimensions are in mm. Angles are in degrees.
2. Dimension and tolerance formats conform to ASME Y14.4M-1994.
3. The terminal #1 identifier and terminal numbering conform to JESD 95-1 SPP-012.

23 Handling Precautions

Parameter	Rating	Standard
ESD – Human Body Model (HBM)	Class 1A	ESDA/JEDEC JS-001-2012
ESD – Charged Device Model (CDM)	Class C3	JEDEC JESD22-C101F
MSL – Moisture Sensitivity Level	Level 3	IPC/JEDEC J-STD-020



Caution!

ESD sensitive device

24 Solderability

Compatible with both lead-free (260 °C max. reflow temperature) and tin/lead (245 °C max. reflow temperature) soldering processes.



PAC5524

High Pin-Count 70V Motor Controller and Driver for BLDC Motors

25 Contact Information

For the latest specifications, additional product information, worldwide sales and distribution locations:

Web: www.qorvo.com

Tel: 1-844-890-8163

Email: customer.support@qorvo.com

26 Important Notice

The information contained herein is believed to be reliable; however, Qorvo makes no warranties regarding the information contained herein and assumes no responsibility or liability whatsoever for the use of the information contained herein. All information contained herein is subject to change without notice. Customers should obtain and verify the latest relevant information before placing orders for Qorvo products. The information contained herein or any use of such information does not grant, explicitly or implicitly, to any party any patent rights, licenses, or any other intellectual property rights, whether with regard to such information itself or anything described by such information. **THIS INFORMATION DOES NOT CONSTITUTE A WARRANTY WITH RESPECT TO THE PRODUCTS DESCRIBED HEREIN, AND QORVO HEREBY DISCLAIMS ANY AND ALL WARRANTIES WITH RESPECT TO SUCH PRODUCTS WHETHER EXPRESS OR IMPLIED BY LAW, COURSE OF DEALING, COURSE OF PERFORMANCE, USAGE OF TRADE OR OTHERWISE, INCLUDING THE IMPLIED WARRANTIES OF MERCHANTABILITY AND FITNESS FOR A PARTICULAR PURPOSE.**

Without limiting the generality of the foregoing, Qorvo products are not warranted or authorized for use as critical components in medical, life-saving, or life-sustaining applications, or other applications where a failure would reasonably be expected to cause severe personal injury or death.

Copyright 2020 © Qorvo, Inc. | Qorvo is a registered trademark of Qorvo, Inc.

Mouser Electronics

Authorized Distributor

Click to View Pricing, Inventory, Delivery & Lifecycle Information:

[Qorvo:](#)

[PAC5524EVK1](#) [PAC5524QF](#) [PAC5524QF-T](#)