



**MICROCHIP**

---

**High-Frequency Clock Source  
Evaluation Board  
User's Guide**

---

---

**Note the following details of the code protection feature on Microchip devices:**

- Microchip products meet the specification contained in their particular Microchip Data Sheet.
- Microchip believes that its family of products is one of the most secure families of its kind on the market today, when used in the intended manner and under normal conditions.
- There are dishonest and possibly illegal methods used to breach the code protection feature. All of these methods, to our knowledge, require using the Microchip products in a manner outside the operating specifications contained in Microchip's Data Sheets. Most likely, the person doing so is engaged in theft of intellectual property.
- Microchip is willing to work with the customer who is concerned about the integrity of their code.
- Neither Microchip nor any other semiconductor manufacturer can guarantee the security of their code. Code protection does not mean that we are guaranteeing the product as "unbreakable."

Code protection is constantly evolving. We at Microchip are committed to continuously improving the code protection features of our products. Attempts to break Microchip's code protection feature may be a violation of the Digital Millennium Copyright Act. If such acts allow unauthorized access to your software or other copyrighted work, you may have a right to sue for relief under that Act.

---

Information contained in this publication regarding device applications and the like is provided only for your convenience and may be superseded by updates. It is your responsibility to ensure that your application meets with your specifications. MICROCHIP MAKES NO REPRESENTATIONS OR WARRANTIES OF ANY KIND WHETHER EXPRESS OR IMPLIED, WRITTEN OR ORAL, STATUTORY OR OTHERWISE, RELATED TO THE INFORMATION, INCLUDING BUT NOT LIMITED TO ITS CONDITION, QUALITY, PERFORMANCE, MERCHANTABILITY OR FITNESS FOR PURPOSE. Microchip disclaims all liability arising from this information and its use. Use of Microchip devices in life support and/or safety applications is entirely at the buyer's risk, and the buyer agrees to defend, indemnify and hold harmless Microchip from any and all damages, claims, suits, or expenses resulting from such use. No licenses are conveyed, implicitly or otherwise, under any Microchip intellectual property rights unless otherwise stated.

*Microchip received ISO/TS-16949:2009 certification for its worldwide headquarters, design and wafer fabrication facilities in Chandler and Tempe, Arizona; Gresham, Oregon and design centers in California and India. The Company's quality system processes and procedures are for its PIC® MCUs and dsPIC® DSCs, KEELOQ® code hopping devices, Serial EEPROMs, microperipherals, nonvolatile memory and analog products. In addition, Microchip's quality system for the design and manufacture of development systems is ISO 9001:2000 certified.*

**QUALITY MANAGEMENT SYSTEM  
CERTIFIED BY DNV  
= ISO/TS 16949 =**

**Trademarks**

The Microchip name and logo, the Microchip logo, AnyRate, AVR, AVR logo, AVR Freaks, BeaconThings, BitCloud, CryptoMemory, CryptoRF, dsPIC, FlashFlex, flexPWR, Heldo, JukeBlox, KEELOQ, KEELOQ logo, Klear, LANCheck, LINK MD, maXStylus, maXTouch, MediaLB, megaAVR, MOST, MOST logo, MPLAB, OptoLyzer, PIC, picoPower, PICSTART, PIC32 logo, Prochip Designer, QTouch, RightTouch, SAM-BA, SpyNIC, SST, SST Logo, SuperFlash, tinyAVR, UNI/O, and XMEGA are registered trademarks of Microchip Technology Incorporated in the U.S.A. and other countries.

ClockWorks, The Embedded Control Solutions Company, EtherSynch, Hyper Speed Control, HyperLight Load, IntelliMOS, mTouch, Precision Edge, and Quiet-Wire are registered trademarks of Microchip Technology Incorporated in the U.S.A.

Adjacent Key Suppression, AKS, Analog-for-the-Digital Age, Any Capacitor, AnyIn, AnyOut, BodyCom, chipKIT, chipKIT logo, CodeGuard, CryptoAuthentication, CryptoCompanion, CryptoController, dsPICDEM, dsPICDEM.net, Dynamic Average Matching, DAM, ECAN, EtherGREEN, In-Circuit Serial Programming, ICSP, Inter-Chip Connectivity, JitterBlocker, KlearNet, KlearNet logo, Mindi, MiWi, motorBench, MPASM, MPF, MPLAB Certified logo, MPLIB, MPLINK, MultiTRAK, NetDetach, Omniscient Code Generation, PICDEM, PICDEM.net, PICKit, PICtail, PureSilicon, QMatrix, RightTouch logo, REAL ICE, Ripple Blocker, SAM-ICE, Serial Quad I/O, SMART-I.S., SQI, SuperSwitcher, SuperSwitcher II, Total Endurance, TSHARC, USBCheck, VariSense, ViewSpan, WiperLock, Wireless DNA, and ZENA are trademarks of Microchip Technology Incorporated in the U.S.A. and other countries.

SQTP is a service mark of Microchip Technology Incorporated in the U.S.A.

Silicon Storage Technology is a registered trademark of Microchip Technology Inc. in other countries.

GestIC is a registered trademark of Microchip Technology Germany II GmbH & Co. KG, a subsidiary of Microchip Technology Inc., in other countries.

All other trademarks mentioned herein are property of their respective companies.

© 2016-2018, Microchip Technology Incorporated, All Rights Reserved.

ISBN: 978-1-5224-2770-4



# HIGH-FREQUENCY CLOCK SOURCE EVALUATION BOARD USER'S GUIDE

---

---

## Table of Contents

---

---

<b>Preface</b> .....	<b>4</b>
Introduction.....	4
Document Layout .....	4
Conventions Used in this Guide .....	5
Recommended Reading.....	6
The Microchip Web Site .....	6
Customer Support .....	6
Document Revision History .....	6
<b>Chapter 1. Quick Start Instruction</b>	
1.1 Description .....	7
1.2 Supply Voltage Setup .....	9
1.3 Oscillator Phase Noise .....	10
<b>Appendix A. Schematics and Layouts</b>	
A.1 Introduction .....	13
A.2 Board – Schematic .....	14
A.3 Board – Top Silk .....	15
A.4 Board – Top Copper and Silk .....	15
A.5 Board – Top Copper .....	16
A.6 Board – Bottom Copper .....	16
A.7 Board – Bottom Copper and Silk .....	17
A.8 Board – Bottom Silk .....	17
A.9 Board – Schematic .....	18
A.10 Board – Top Silk .....	19
A.11 Board – Top Copper and Silk .....	19
A.12 Board – Top Copper .....	20
A.13 Board – Bottom Copper .....	20
A.14 Board – Bottom Copper and Silk .....	21
A.15 Board – Bottom Silk .....	21
<b>Appendix B. Bill of Materials (BOM)</b> .....	<b>23</b>
<b>Worldwide Sales and Service</b> .....	<b>26</b>



# HIGH-FREQUENCY CLOCK SOURCE EVALUATION BOARD USER'S GUIDE

## Preface

### NOTICE TO CUSTOMERS

All documentation becomes dated, and this manual is no exception. Microchip tools and documentation are constantly evolving to meet customer needs, so some actual dialogs and/or tool descriptions may differ from those in this document. Please refer to our website ([www.microchip.com](http://www.microchip.com)) to obtain the latest documentation available.

Documents are identified with a “DS” number. This number is located on the bottom of each page, in front of the page number. The numbering convention for the DS number is “DSXXXXXXXXA”, where “XXXXXXXX” is the document number and “A” is the revision level of the document.

For the most up-to-date information on development tools, see the MPLAB® IDE online help. Select the Help menu, and then Topics to open a list of available online help files.

## INTRODUCTION

This chapter contains general information that will be useful to know before using the High-Frequency Clock Source Evaluation Board. Items discussed in this chapter include:

- Document Layout
- Conventions Used in this Guide
- Recommended Reading
- The Microchip Web Site
- Customer Support
- Document Revision History

## DOCUMENT LAYOUT

This document describes how to use the High-Frequency Clock Source Evaluation Board. The manual layout is as follows:

- **Chapter 1. “Quick Start Instruction”** – Important information about the High-Frequency Clock Source Evaluation Board.
- **Appendix A. “Schematics and Layouts”** – Shows the schematic and layout diagrams.
- **Appendix B. “Bill of Materials (BOM)”** – Lists the parts used to build the High-Frequency Clock Source Evaluation Board.

## CONVENTIONS USED IN THIS GUIDE

This manual uses the following documentation conventions:

### DOCUMENTATION CONVENTIONS

Description	Represents	Examples
<b>Arial font:</b>		
Italic characters	Referenced books	<i>MPLAB<sup>®</sup> IDE User's Guide</i>
	Emphasized text	...is the <i>only</i> compiler...
Initial caps	A window	the Output window
	A dialog	the Settings dialog
	A menu selection	select Enable Programmer
Quotes	A field name in a window or dialog	"Save project before build"
Underlined, Italic text with right angle bracket	A menu path	<u><i>File&gt;Save</i></u>
Bold characters	A dialog button	Click <b>OK</b>
	A tab	Click the <b>Power</b> tab
N'Rnnnn	A number in verilog format, where N is the total number of digits, R is the radix and n is a digit.	4'b0010, 2'hF1
Text in angle brackets < >	A key on the keyboard	Press <Enter>, <F1>
<b>Courier New font:</b>		
Plain Courier New	Sample source code	#define START
	Filenames	autoexec.bat
	File paths	c:\mcc18\h
	Keywords	_asm, _endasm, static
	Command-line options	-Opa+, -Opa-
	Bit values	0, 1
	Constants	0xFF, 'A'
Italic Courier New	A variable argument	<i>file.o</i> , where <i>file</i> can be any valid filename
Square brackets [ ]	Optional arguments	mcc18 [options] <i>file</i> [options]
Curly brackets and pipe character: {   }	Choice of mutually exclusive arguments; an OR selection	errorlevel {0 1}
Ellipses...	Replaces repeated text	var_name [, var_name...]
	Represents code supplied by user	void main (void) { ... }

## RECOMMENDED READING

This user's guide describes how to use the High-Frequency Clock Source Evaluation Board. Other useful documents are listed below. The following Microchip documents are available and recommended as supplemental reference resources.

- **MX575ABC200M000 Data Sheet** – “*Ultra-Low Jitter 200 MHz LVCMOS XO*” (Available using the ClockWorks® Configurator software available on the device product page).
- **MCP37231-200 Data Sheet** – “*200 Msps, 16-/14-Bit Low-Power ADC with 8-Channel MUX*” (DS20005322).

## THE MICROCHIP WEB SITE

Microchip provides online support via our web site at [www.microchip.com](http://www.microchip.com). This web site is used as a means to make files and information easily available to customers. Accessible by using your favorite Internet browser, the web site contains the following information:

- **Product Support** – Data sheets and errata, application notes and sample programs, design resources, user's guides and hardware support documents, latest software releases and archived software.
- **General Technical Support** – Frequently Asked Questions (FAQs), technical support requests, online discussion groups, Microchip consultant program member listing.
- **Business of Microchip** – Product selector and ordering guides, latest Microchip press releases, listing of seminars and events, listings of Microchip sales offices, distributors and factory representatives.

## CUSTOMER SUPPORT

Users of Microchip products can receive assistance through several channels:

- Distributor or Representative
- Local Sales Office
- Field Application Engineer (FAE)
- Technical Support

Customers should contact their distributor, representative or field application engineer (FAE) for support. Local sales offices are also available to help customers. A listing of sales offices and locations is included in the back of this document.

Technical support is available through the web site at:  
<http://www.microchip.com/support>.

## DOCUMENT REVISION HISTORY

### Revision B (March 2018)

- Updated the evaluation board part number references throughout document (ADM00724->ADM00791).
- Updated [Appendix A. “Schematics and Layouts”](#) and [Appendix B. “Bill of Materials \(BOM\)”](#).

### Revision A (May 2016)

- Initial Release of this Document.

## Chapter 1. Quick Start Instruction

### 1.1 DESCRIPTION

The High-Frequency Clock Source Evaluation Board is an easy-to-use, high-frequency clock source. It contains a low-noise crystal-oscillator (TCXO, single-ended output). The oscillator requires a 3.3V supply voltage. The output is available at the SMA connector through a bandpass filter (ADM00725) or without the filter (ADM00791).

The evaluation board is initially developed to be used as clock source for Microchip Technology's High Speed ADC Evaluation Boards for the MCP37XXX family devices. However, its application can expand into RF and other mixed signal applications as well, where a low noise clock is needed.

[Table 1-1](#) shows the summary of the boards that are currently available from Microchip Technology. [Figure 1-1](#) shows the photos of the boards.

**TABLE 1-1: HIGH FREQUENCY CLOCK SOURCE EVALUATION BOARDS (Note 1)**

Evaluation Board Part Number	Crystal Oscillator Part Number	Output Frequency	Output Filter	Descriptions
ADM00791	MX575ABC200M000	200 MHz	Not Included	200 MHz clock source
ADM00725		200 MHz	Included	200 MHz clock source with bandpass filter ( <a href="#">Note 2</a> )

**Note 1:** Contact Microchip Technology for the availability of released evaluation boards for other frequency bands.

**2:** Clock source with a filter (ADM00725) is highly recommended for applications where lower harmonic distortion is needed.

# Quick Start Instruction

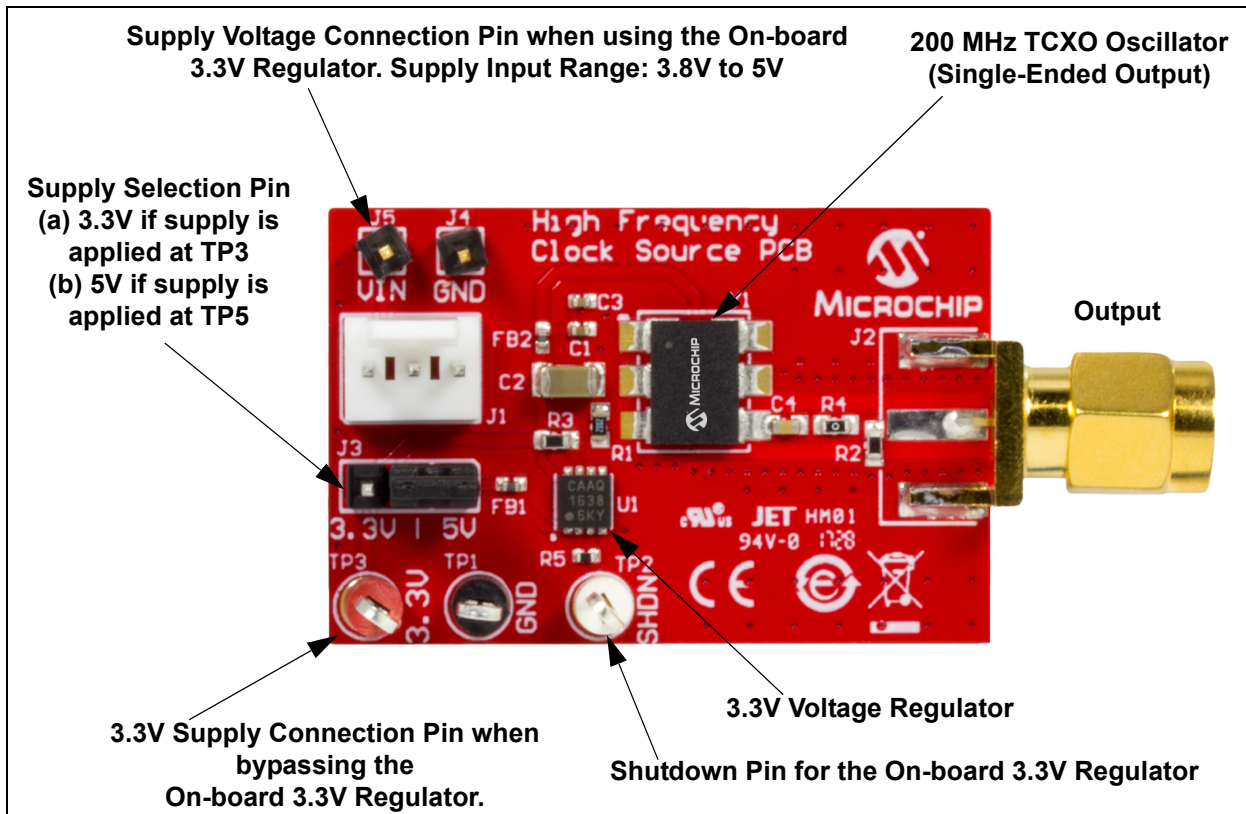

(a) ADM00791: 200 MHz Clock Source Evaluation Board

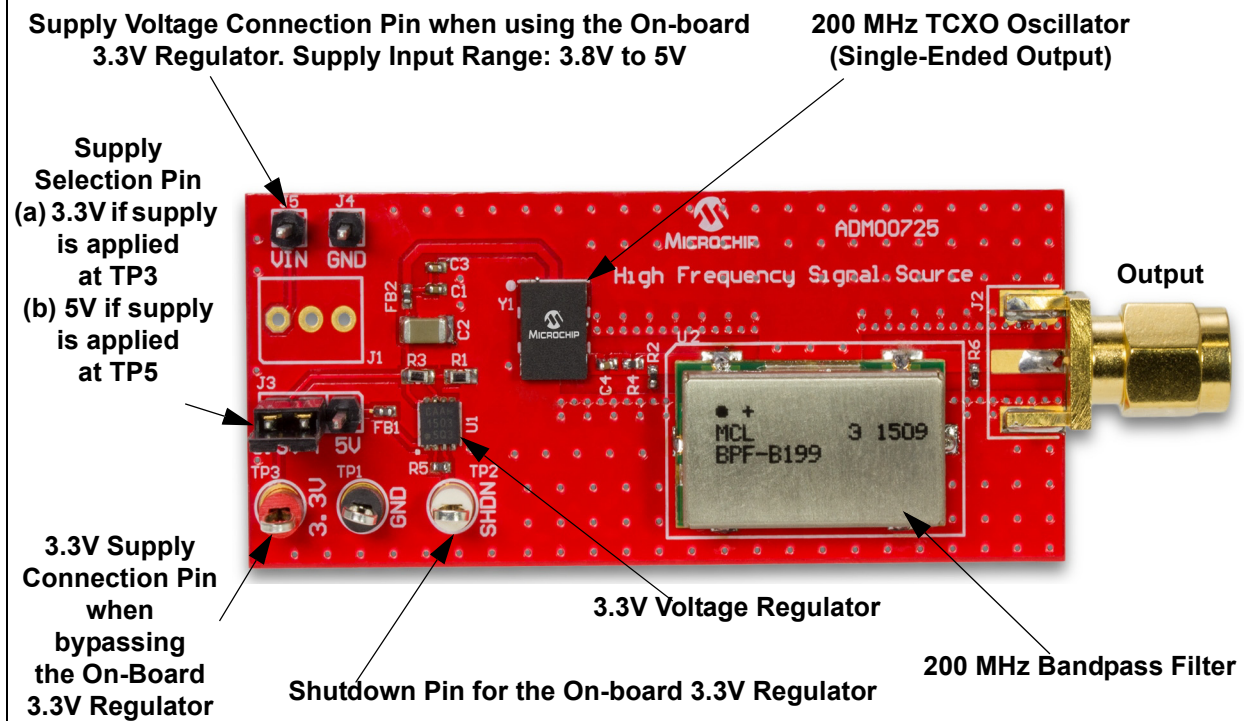

(b) ADM00725: 200 MHz Clock Source Evaluation Board with Bandpass Filter

FIGURE 1-1: High-Frequency Clock Source Evaluation Boards.



## 1.2 SUPPLY VOLTAGE SETUP

Figure 1-2 shows the block diagram of the evaluation board.

### Applying Supply Voltage

The oscillator requires a 3.3V supply voltage. The board includes a 3.3V regulator. The supply voltage applied to the  $V_{IN}$  pin (J5) is connected to the input pin of the regulator. Note that the user can provide an exact 3.3V supply at TP3 instead of using the on-board regulator.

### Supply Voltage Option

One of the following two choices can be used.

1. When using on-board 3.3V regulator:
  - Provide 3.8V to 5V supply at J5 pin (Positive) and J4 pin (Negative).
  - Connect J3 Jumper to 5V
2. When providing 3.3V supply without using the on-board 3.3V regulator:
  - Provide 3.3V supply at TP3 (Positive) and GND pin.
  - Connect J3 Jumper to 3.3V

Once the supply voltage is applied, a clean 200 MHz LVCMOS output is available at the SMA connector. The output impedance is controlled for 50Ω.

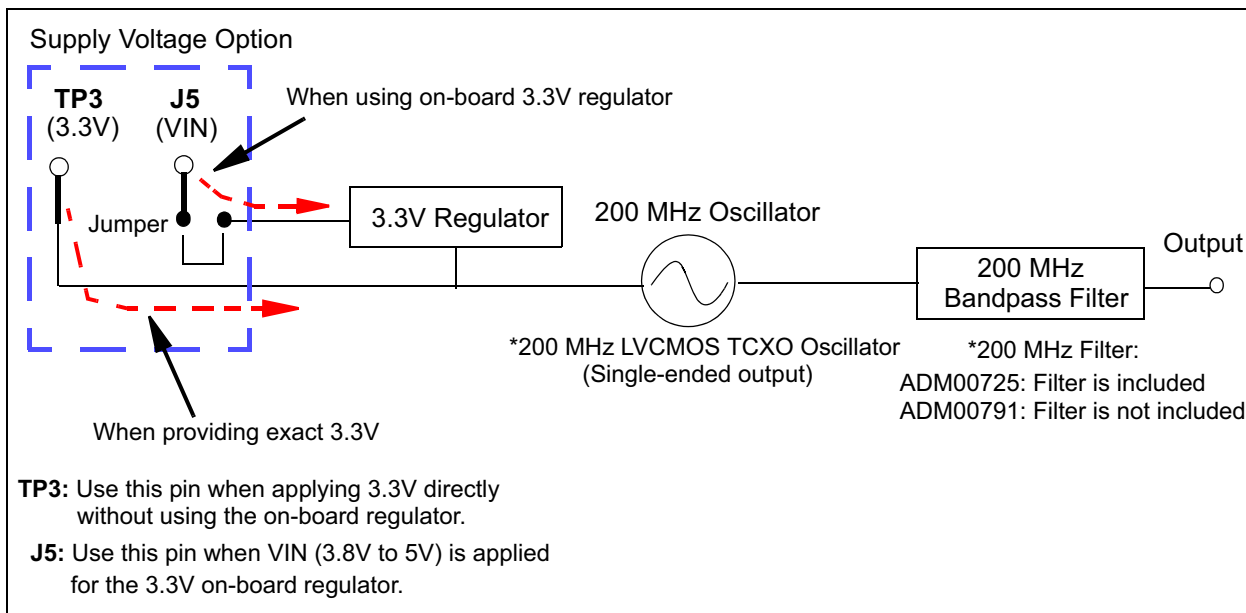

**FIGURE 1-2:** Evaluation Board Block Diagram.

## 1.3 OSCILLATOR PHASE NOISE

Figure 1-3 shows the oscillator phase noise plots for the ADM00791 and ADM00725.

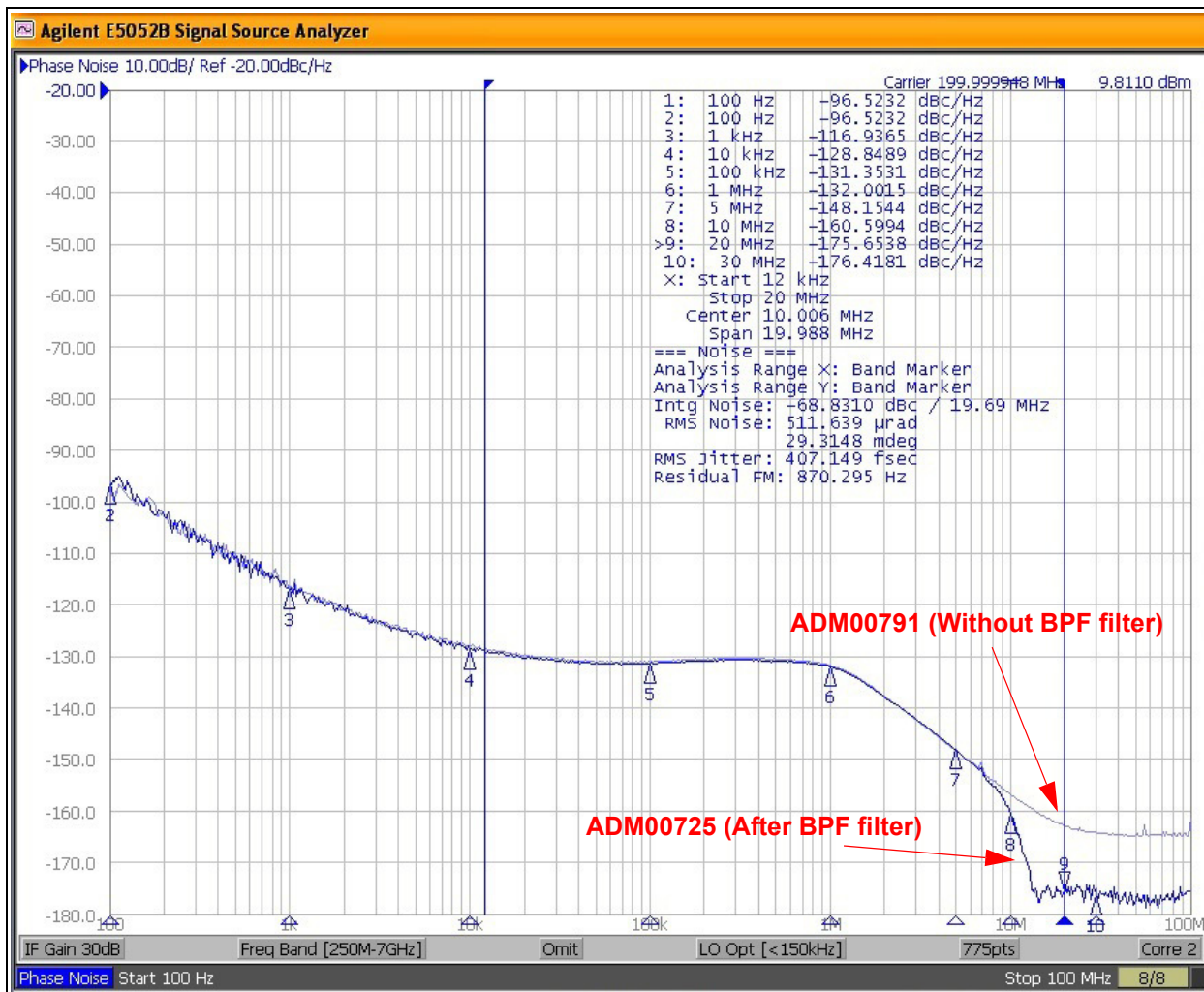
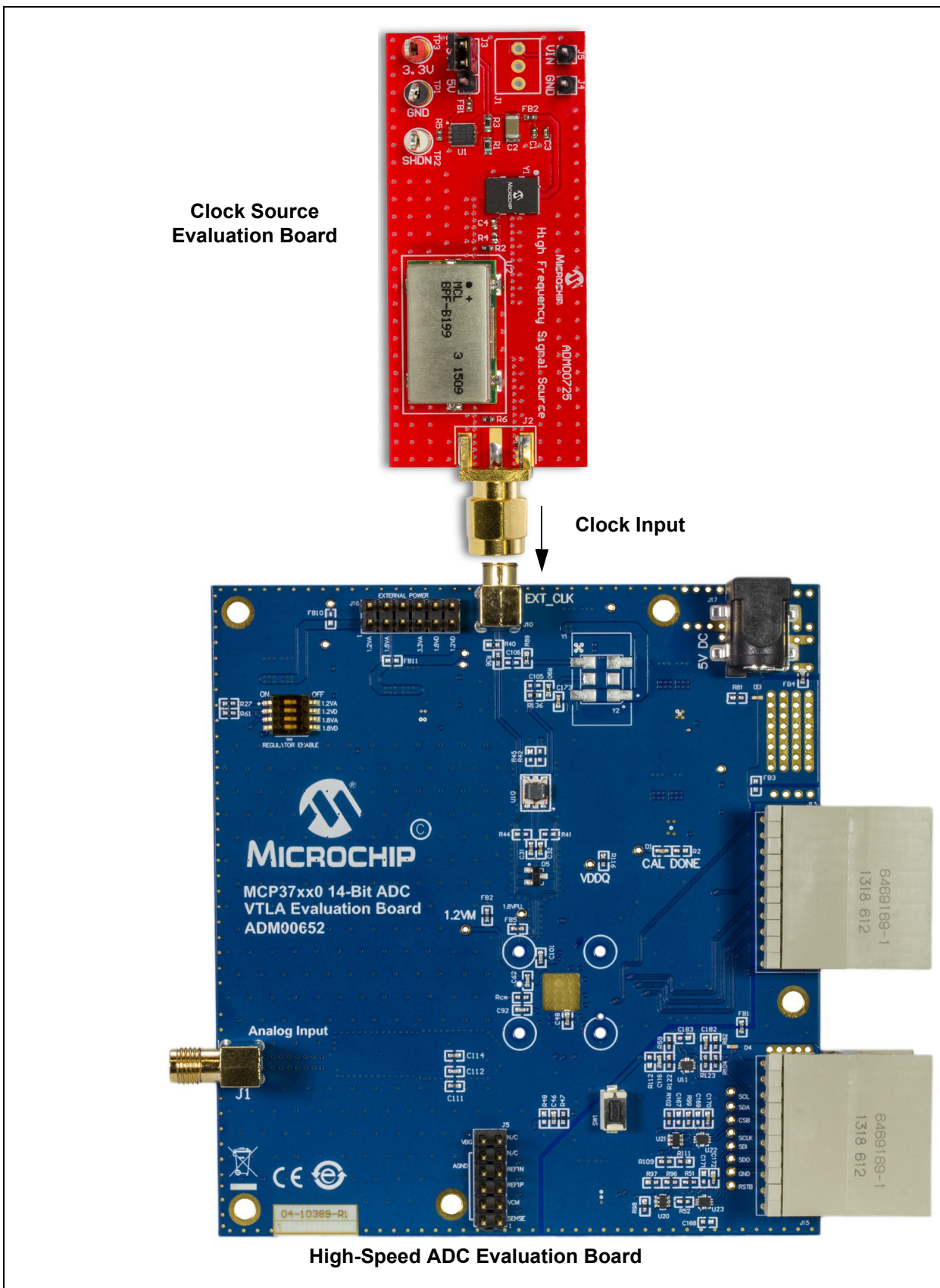

FIGURE 1-3: Phase Noise Plot.



**FIGURE 1-4:** Application Example: When the Clock Source Evaluation Board is used with the MCP37XX0 High-Speed ADC Evaluation Board.

NOTES:



## Appendix A. Schematics and Layouts

---

---

### A.1 INTRODUCTION

This appendix contains the following schematics and layouts for the High-Frequency Clock Source Evaluation Board:

#### **ADM00791**

- Board – Schematic
- Board – Top Silk
- Board – Top Copper and Silk
- Board – Top Copper
- Board – Bottom Copper
- Board – Bottom Copper and Silk
- Board – Bottom Silk

#### **ADM00725**

- Board – Schematic
- Board – Top Silk
- Board – Top Copper and Silk
- Board – Top Copper
- Board – Bottom Copper
- Board – Bottom Copper and Silk
- Board – Bottom Silk

## A.2 BOARD – SCHEMATIC

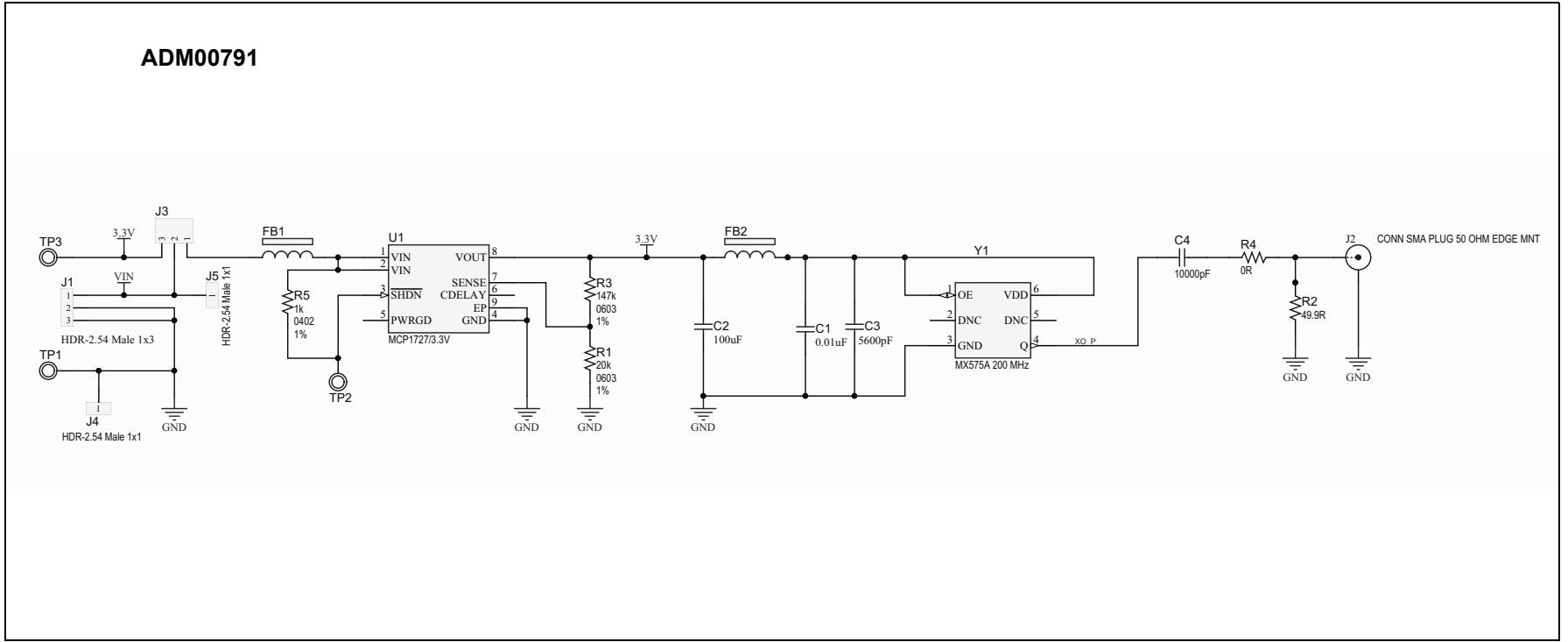

## A.3 BOARD – TOP SILK

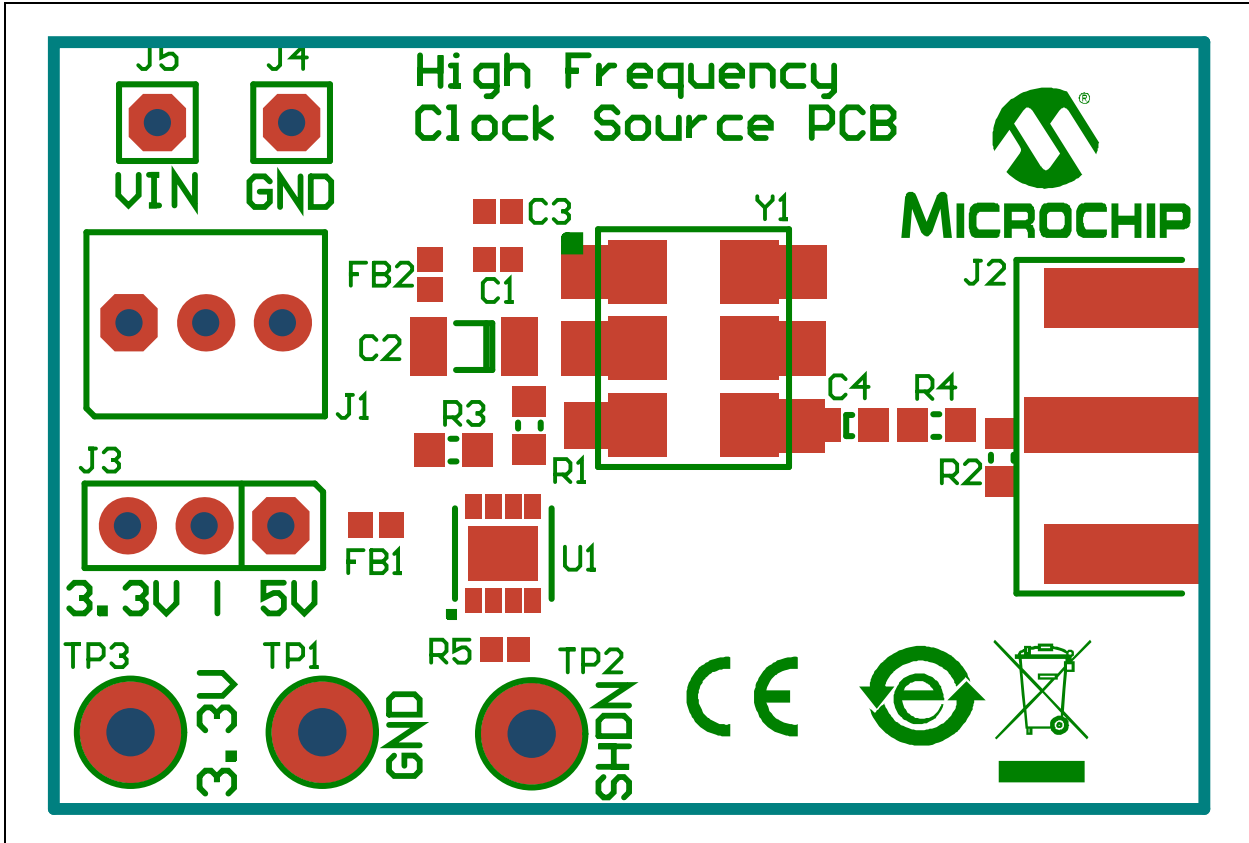

## A.4 BOARD – TOP COPPER AND SILK

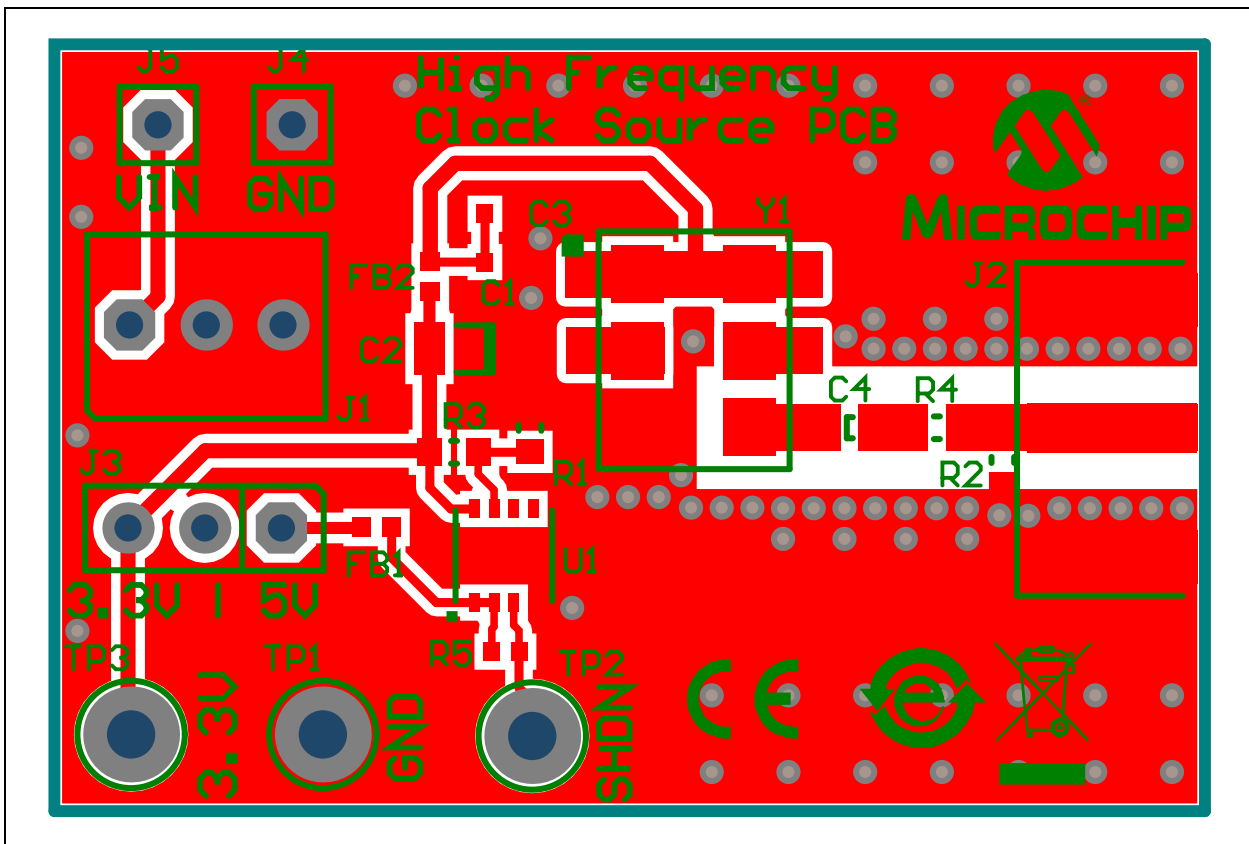

## A.5 BOARD – TOP COPPER

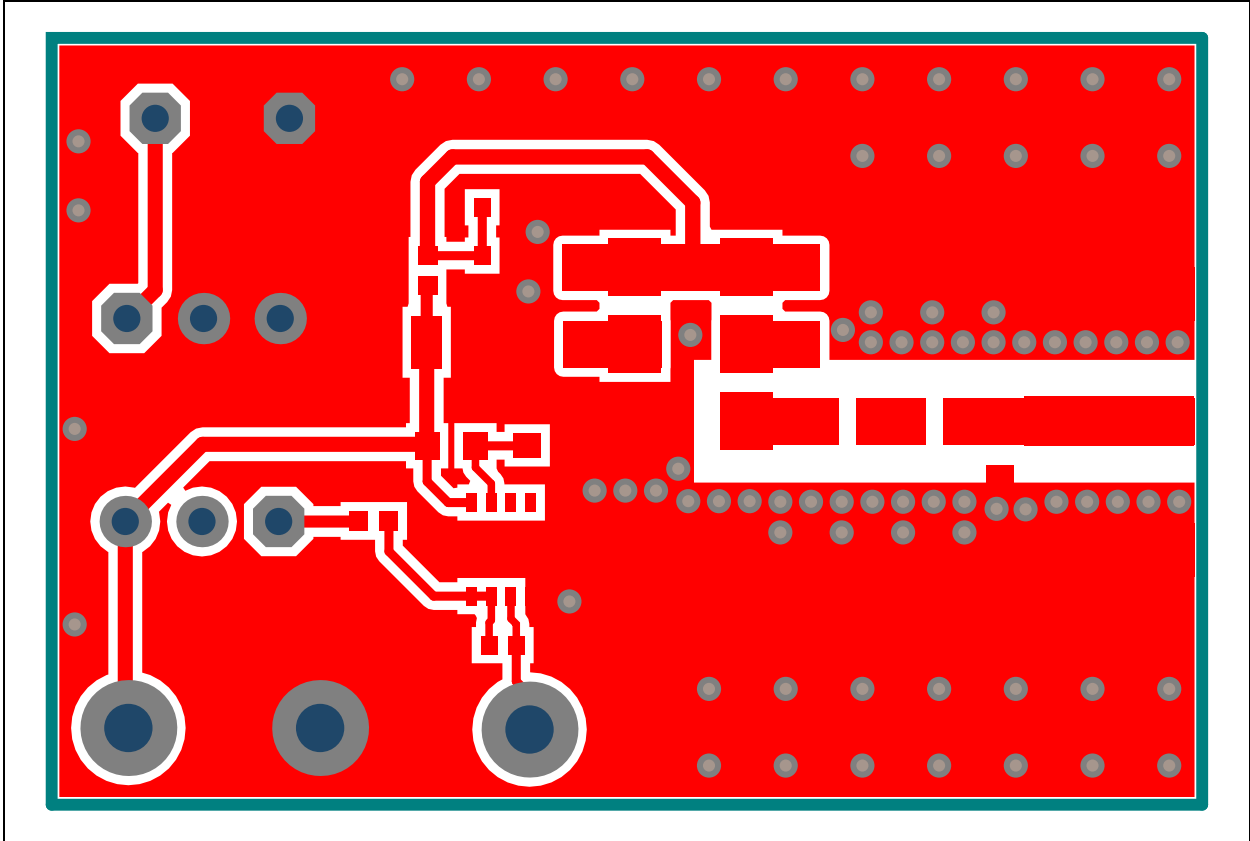

## A.6 BOARD – BOTTOM COPPER

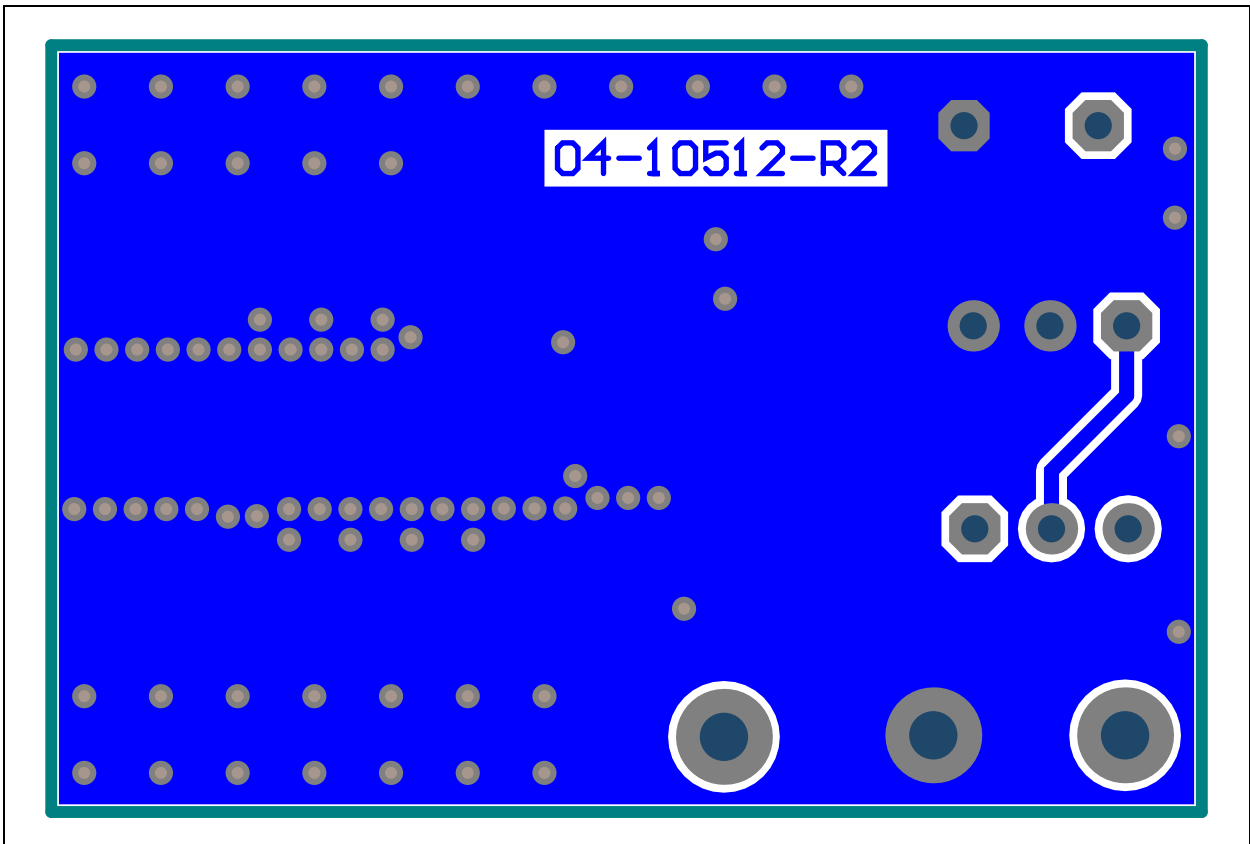



## A.7 BOARD – BOTTOM COPPER AND SILK

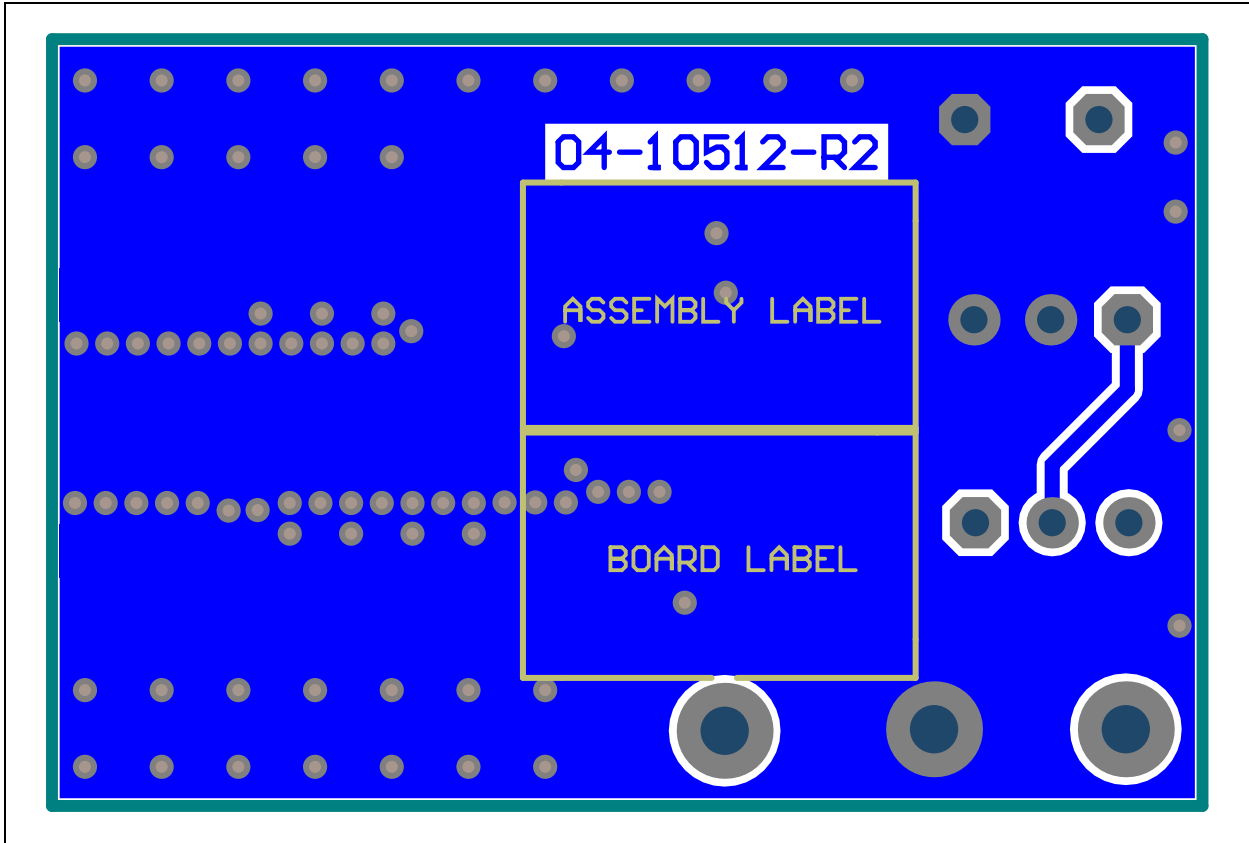

## A.8 BOARD – BOTTOM SILK

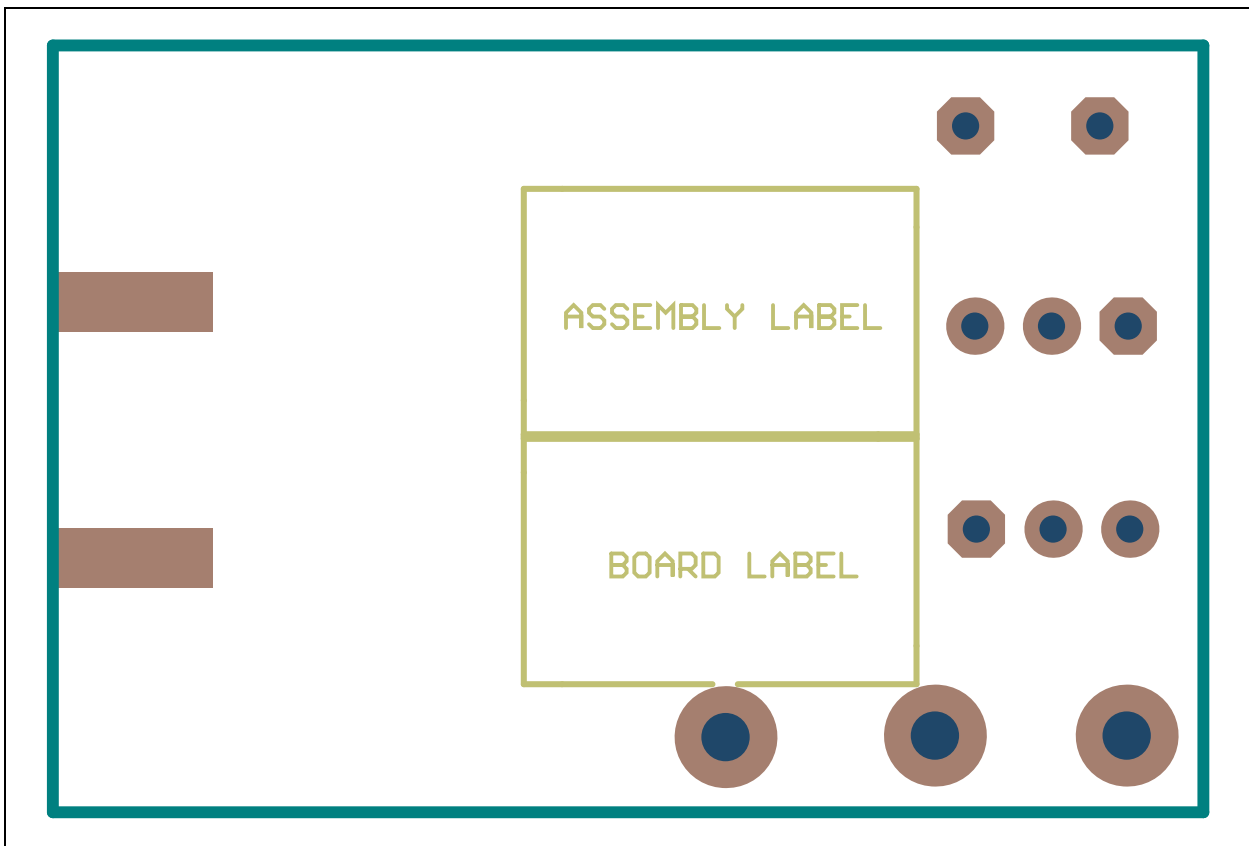

## A.9 BOARD – SCHEMATIC

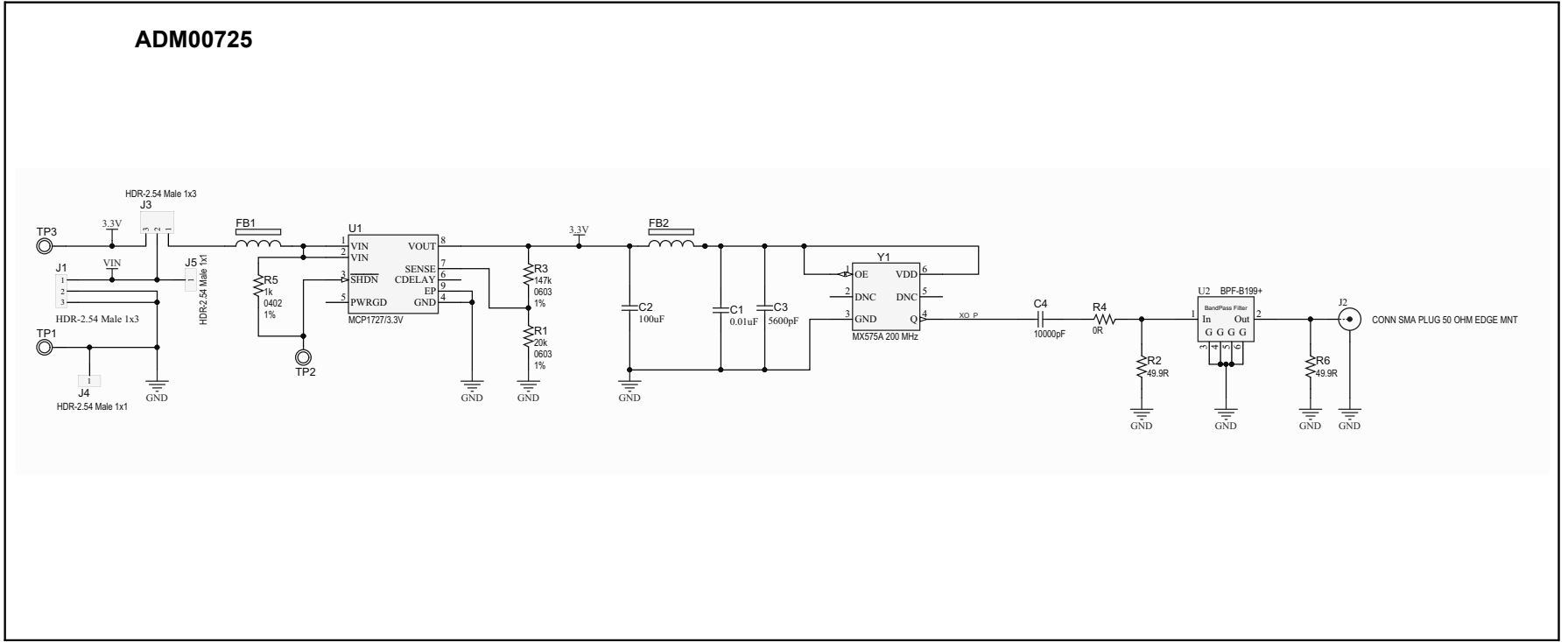

## A.10 BOARD – TOP SILK

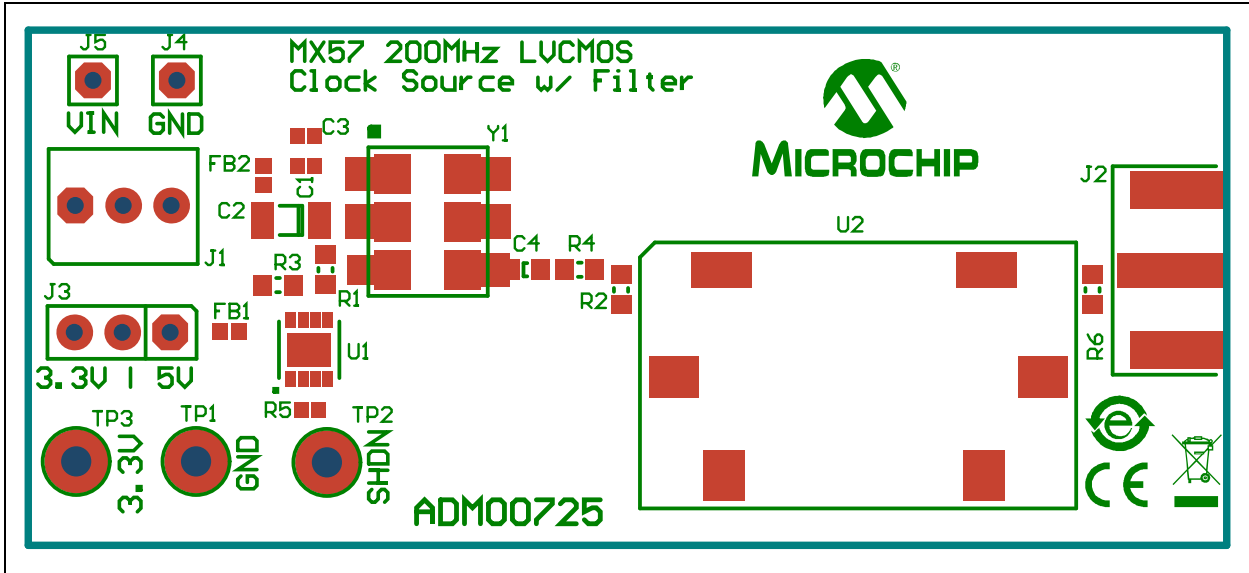

## A.11 BOARD – TOP COPPER AND SILK

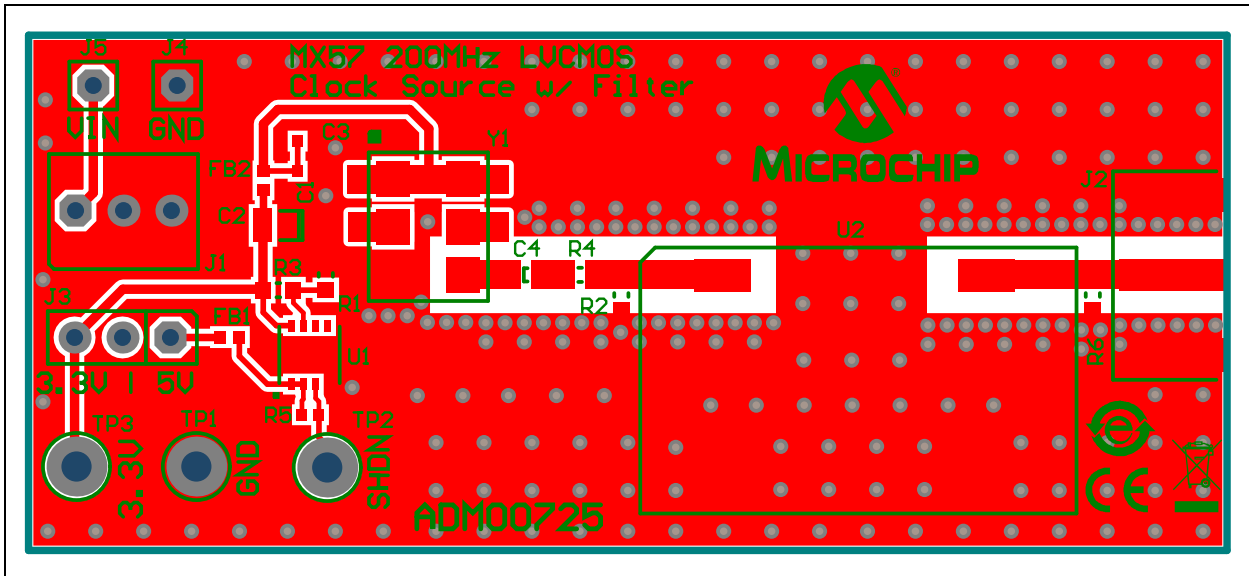

## A.12 BOARD – TOP COPPER

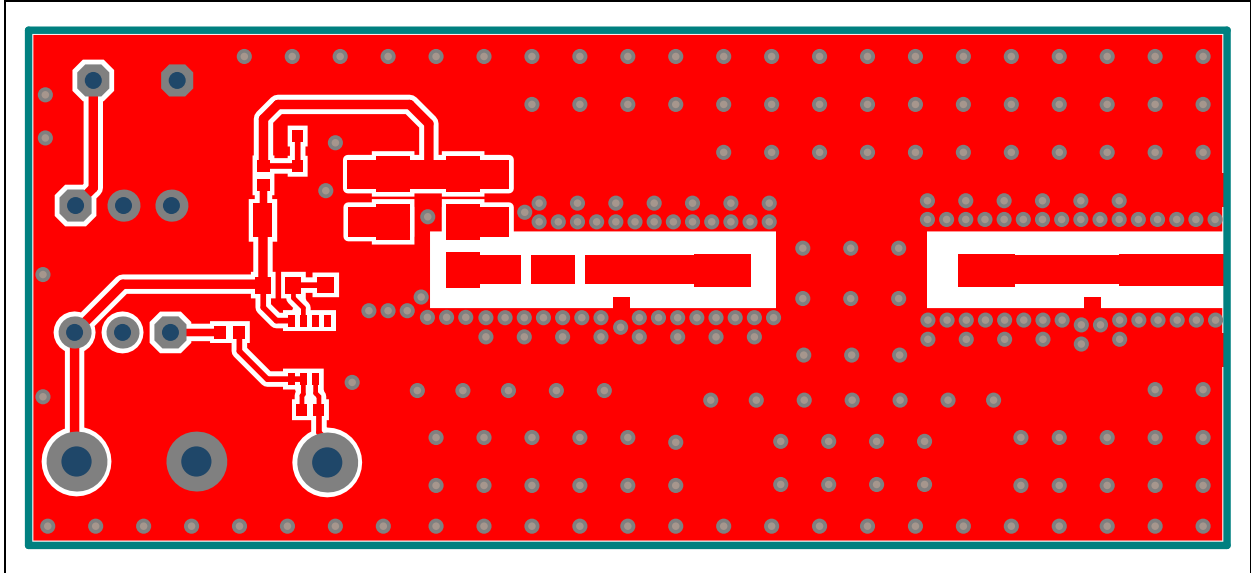

## A.13 BOARD – BOTTOM COPPER

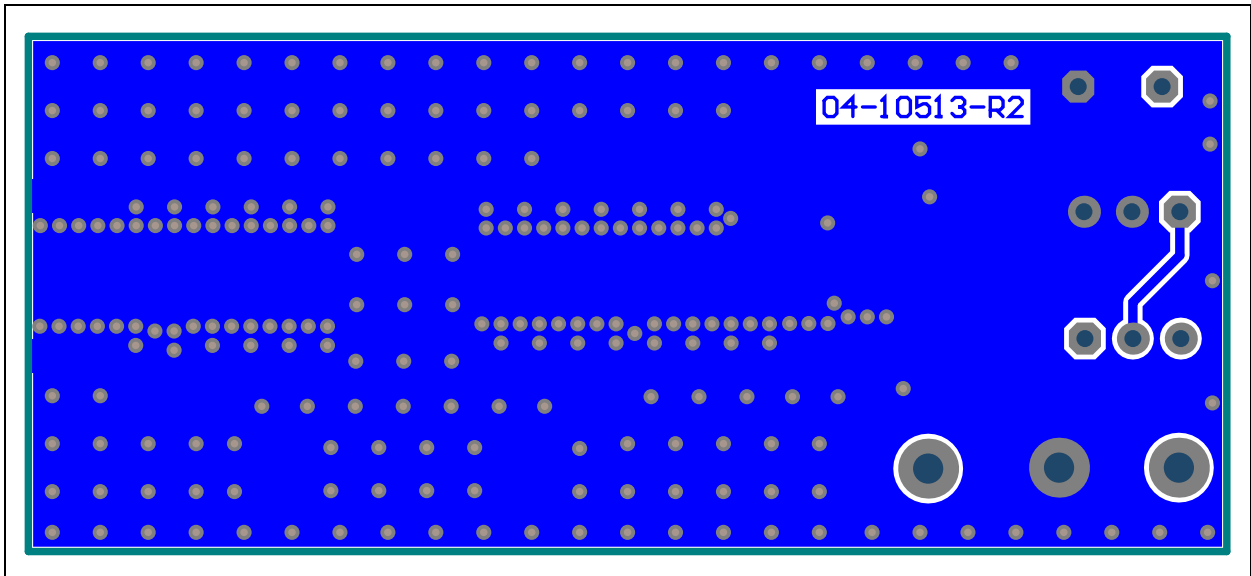

## A.14 BOARD – BOTTOM COPPER AND SILK

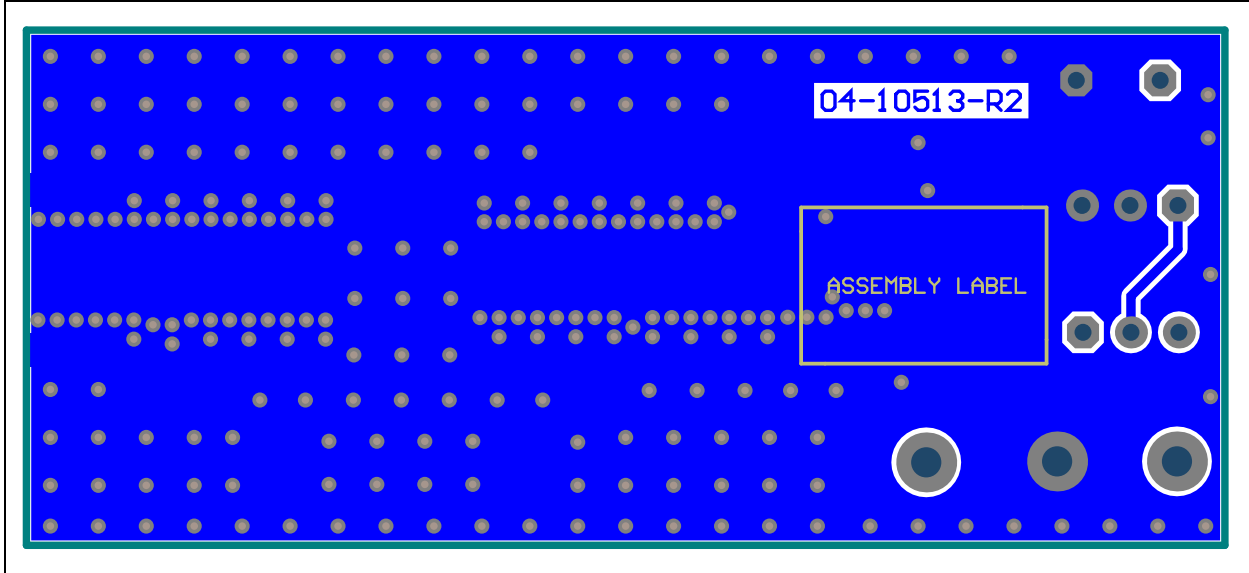

## A.15 BOARD – BOTTOM SILK

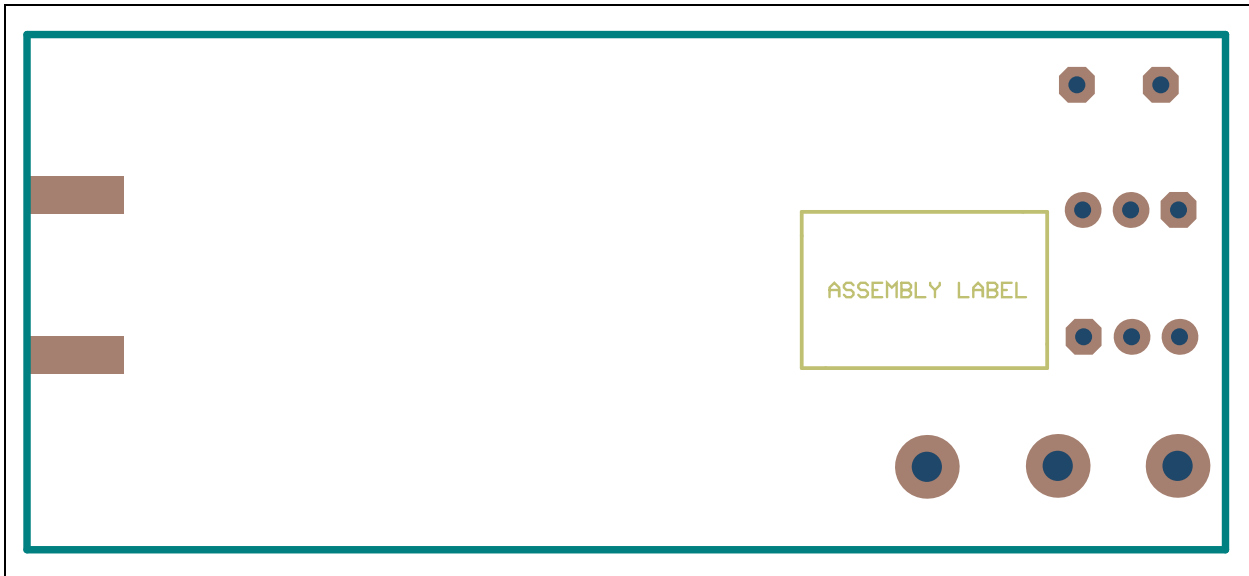

NOTES:



# HIGH-FREQUENCY CLOCK SOURCE EVALUATION BOARD USER'S GUIDE

## Appendix B. Bill of Materials (BOM)

**TABLE B-1: ADM00791 BILL OF MATERIALS (BOM)**

Qty.	Reference	Description	Manufacturer	Part Number
2	C1, C4	Capacitor ceramic, 0.01 $\mu$ F, 16V, 10%, X7R, SMD, 0402	KEMET	C0402C103K4RACTU
1	C2	Capacitor ceramic, 100 $\mu$ F, 6.3V, 20%, X5R, SMD, 1206	Murata Electronics®	GRM31CR60J107ME39L
1	C3	Capacitor ceramic, 5600 PF, 50V, 10%, X7R, 0402	Samsung Electro-Mechanics America, Inc.	CL05B562KB5NNNC
2	FB1, FB2	Ferrite Chip, 5 $\Omega$ , 300 MA, 0402	Murata Electronics®	BLM15BA050SN1D
1	J1	Connector Header-2.54 male, 1x3 tin lock, 7.49 MH TH. vertical	Molex®	0022272031
1	J2	Connector, SMA Plug, 50 $\Omega$ Edge mount	Amphenol Commercial	132365-10
1	J3	Connector, Header-2.54 male, 1x3 tin, 5.84 MH, TH, vertical	Samtec, Inc.	TSW-103-07-T-S
2	J4, J5	Connector Header-2.54 male, 1x1 gold, 5.97 MH, TH, vertical.	Samtec, Inc.	TSW-101-07-L-S
1	PCB	Printed Circuit Board – High-Frequency Clock Source Evaluation Board	Microchip Technology Inc.	04-10512
1	R1	Resistor TKF., 20 k $\Omega$ , 1%, 1/10W, SMD, 0603	Yageo Corporation	9C06031A2002FKHFT
1	R2	Resistor, SMD., 49.9 $\Omega$ , 0.1%, 1/16W, 0402	Panasonic® – ECG	ERA-2AEB49R9X
1	R3	Resistor, TKF., 147 k $\Omega$ , 1%, 1/10W, SMD, 0603	Panasonic – ECG	ERJ-3EKF1473V
1	R4	Resistor, TKF., 0R, 1/16W, SMD., 0402	Yageo Corporation	RC0402JR-070RL
1	R5	Resistor, TKF., 1 k $\Omega$ , 1%, 1/10W, SMD., 0402	Panasonic – ECG	ERJ-2RKF1001X
1	TP1	Connector, TP, loop black, TH.	Keystone Electronics Corp.	5011
1	TP2	Connector, TP, loop white, TH.	Keystone Electronics Corp.	5012
1	TP3	Connector, TP, loop red, TH.	Keystone Electronics Corp.	5010
1	U1	Microchip Analog LDO 3.3V MCP1727T-3302E/MF DFN-8	Microchip Technology Inc.	<b>MCP1727T-3302E/MF</b>
1	Y1	$\pm$ 2.5 ppm Stability 200 MHz LVCMOS TCXO	Microchip Technology Inc.	<b>MX575ABC200M000</b>

**Note:** The components listed in this Bill of Materials are representative of the PCB assembly. The released BOM used in manufacturing uses all RoHS-compliant components.

# Bill of Materials (BOM)

**TABLE B-2: ADM00725 BILL OF MATERIALS (BOM)**

Qty.	Reference	Description	Manufacturer	Part Number
2	C1, C4	Capacitor ceramic, 0.01 $\mu$ F, 16V, 10%, X7R, SMD, 0402	KEMET	C0402C103K4RACTU
1	C2	Capacitor ceramic, 100 $\mu$ F, 6.3V, 20%, X5R, SMD, 1206	Murata Electronics®	GRM31CR60J107ME39L
1	C3	Capacitor ceramic, 5600 pF, 50V, 10%, X7R, 0402	Samsung Electro-Mechanics America, Inc.	CL05B562KB5NNNC
2	FB1, FB2	Ferrite Chip, 5 $\Omega$ , 300MA, 0402	Murata Electronics	BLM15BA050SN1D
1	J1	Connector Header-2.54 male, 1x3 tin lock, 7.49 MH, TH, vertical	Molex®	0022272031
1	J2	Connector SMA Plug, 50 $\Omega$ , Edge mount	Amphenol Commercial	132365-10
1	J3	Connector Header-2.54, male 1x3, tin, 5.84 MH, TH, vertical	Samtec, Inc.	TSW-103-07-T-S
2	J4, J5	Connector Header-2.54, male, 1x1 gold, 5.97 MH, TH, vertical	Samtec, Inc.	TSW-101-07-L-S
1	PCB	Printed Circuit Board – High-Frequency Clock Source Evaluation Board	Microchip Technology Inc.	04-10513
1	R1	Resistor, TKF, 20 k $\Omega$ , 1%, 1/10W, SMD, 0603	Yageo Corporation	9C06031A2002FKHFT
2	R2, R6	Resistor, SMD, 49.9 $\Omega$ , 0.1%, 1/16W, 0402	Panasonic® – ECG	ERA-2AEB49R9X
1	R3	Resistor, TKF, 147 k $\Omega$ , 1%, 1/10W, SMD, 0603	Panasonic – ECG	ERJ-3EKF1473V
1	R4	Resistor, TKF, 0 $\Omega$ , 1/16W, SMD, 0402	Yageo Corporation	RC0402JR-070RL
1	R5	Resistor, TKF, 1 k $\Omega$ , 1%, 1/10W, SMD, 0402	Panasonic – ECG	ERJ-2RKF1001X
1	TP1	Connector, TP, loop, black, TH	Keystone Electronics Corp.	5011
1	TP2	Connector, TP, loop, white TH	Keystone Electronics Corp.	5012
1	TP3	Connector, TP, loop, red, TH	Keystone Electronics Corp.	5010
1	U1	Microchip Analog LDO 3.3V MCP1727T-3302E/MF DFN-8	Microchip Technology Inc.	<b>MCP1727T-3302E/MF</b>
1	U2	IC Filter Band Pass. 194 TO 204 MHZ HZ1198 SMD	Mini-Circuits®	BPF-B199+
1	Y1	$\pm$ 2.5 ppm Stability 200 MHz LVCMOS TCXO	Microchip Technology Inc.	<b>MX575ABC200M000</b>

**Note:** The components listed in this Bill of Materials are representative of the PCB assembly. The released BOM used in manufacturing uses all RoHS-compliant components.





# MICROCHIP

## Worldwide Sales and Service

### AMERICAS

**Corporate Office**  
2355 West Chandler Blvd.  
Chandler, AZ 85224-6199  
Tel: 480-792-7200  
Fax: 480-792-7277  
Technical Support:  
<http://www.microchip.com/support>  
Web Address:  
[www.microchip.com](http://www.microchip.com)

#### Atlanta

Duluth, GA  
Tel: 678-957-9614  
Fax: 678-957-1455

#### Austin, TX

Tel: 512-257-3370

#### Boston

Westborough, MA  
Tel: 774-760-0087  
Fax: 774-760-0088

#### Chicago

Itasca, IL  
Tel: 630-285-0071  
Fax: 630-285-0075

#### Dallas

Addison, TX  
Tel: 972-818-7423  
Fax: 972-818-2924

#### Detroit

Novi, MI  
Tel: 248-848-4000

#### Houston, TX

Tel: 281-894-5983

#### Indianapolis

Noblesville, IN  
Tel: 317-773-8323  
Fax: 317-773-5453  
Tel: 317-536-2380

#### Los Angeles

Mission Viejo, CA  
Tel: 949-462-9523  
Fax: 949-462-9608  
Tel: 951-273-7800

#### Raleigh, NC

Tel: 919-844-7510

#### New York, NY

Tel: 631-435-6000

#### San Jose, CA

Tel: 408-735-9110  
Tel: 408-436-4270

#### Canada - Toronto

Tel: 905-695-1980  
Fax: 905-695-2078

### ASIA/PACIFIC

**Australia - Sydney**  
Tel: 61-2-9868-6733

**China - Beijing**  
Tel: 86-10-8569-7000

**China - Chengdu**  
Tel: 86-28-8665-5511

**China - Chongqing**  
Tel: 86-23-8980-9588

**China - Dongguan**  
Tel: 86-769-8702-9880

**China - Guangzhou**  
Tel: 86-20-8755-8029

**China - Hangzhou**  
Tel: 86-571-8792-8115

**China - Hong Kong SAR**  
Tel: 852-2943-5100

**China - Nanjing**  
Tel: 86-25-8473-2460

**China - Qingdao**  
Tel: 86-532-8502-7355

**China - Shanghai**  
Tel: 86-21-3326-8000

**China - Shenyang**  
Tel: 86-24-2334-2829

**China - Shenzhen**  
Tel: 86-755-8864-2200

**China - Suzhou**  
Tel: 86-186-6233-1526

**China - Wuhan**  
Tel: 86-27-5980-5300

**China - Xian**  
Tel: 86-29-8833-7252

**China - Xiamen**  
Tel: 86-592-2388138

**China - Zhuhai**  
Tel: 86-756-3210040

### ASIA/PACIFIC

**India - Bangalore**  
Tel: 91-80-3090-4444

**India - New Delhi**  
Tel: 91-11-4160-8631

**India - Pune**  
Tel: 91-20-4121-0141

**Japan - Osaka**  
Tel: 81-6-6152-7160

**Japan - Tokyo**  
Tel: 81-3-6880-3770

**Korea - Daegu**  
Tel: 82-53-744-4301

**Korea - Seoul**  
Tel: 82-2-554-7200

**Malaysia - Kuala Lumpur**  
Tel: 60-3-7651-7906

**Malaysia - Penang**  
Tel: 60-4-227-8870

**Philippines - Manila**  
Tel: 63-2-634-9065

**Singapore**  
Tel: 65-6334-8870

**Taiwan - Hsin Chu**  
Tel: 886-3-577-8366

**Taiwan - Kaohsiung**  
Tel: 886-7-213-7830

**Taiwan - Taipei**  
Tel: 886-2-2508-8600

**Thailand - Bangkok**  
Tel: 66-2-694-1351

**Vietnam - Ho Chi Minh**  
Tel: 84-28-5448-2100

### EUROPE

**Austria - Wels**  
Tel: 43-7242-2244-39  
Fax: 43-7242-2244-393

**Denmark - Copenhagen**  
Tel: 45-4450-2828  
Fax: 45-4485-2829

**Finland - Espoo**  
Tel: 358-9-4520-820

**France - Paris**  
Tel: 33-1-69-53-63-20  
Fax: 33-1-69-30-90-79

**Germany - Garching**  
Tel: 49-8931-9700

**Germany - Haan**  
Tel: 49-2129-3766400

**Germany - Heilbronn**  
Tel: 49-7131-67-3636

**Germany - Karlsruhe**  
Tel: 49-721-625370

**Germany - Munich**  
Tel: 49-89-627-144-0  
Fax: 49-89-627-144-44

**Germany - Rosenheim**  
Tel: 49-8031-354-560

**Israel - Ra'anana**  
Tel: 972-9-744-7705

**Italy - Milan**  
Tel: 39-0331-742611  
Fax: 39-0331-466781

**Italy - Padova**  
Tel: 39-049-7625286

**Netherlands - Drunen**  
Tel: 31-416-690399  
Fax: 31-416-690340

**Norway - Trondheim**  
Tel: 47-7289-7561

**Poland - Warsaw**  
Tel: 48-22-3325737

**Romania - Bucharest**  
Tel: 40-21-407-87-50

**Spain - Madrid**  
Tel: 34-91-708-08-90  
Fax: 34-91-708-08-91

**Sweden - Gothenberg**  
Tel: 46-31-704-60-40

**Sweden - Stockholm**  
Tel: 46-8-5090-4654

**UK - Wokingham**  
Tel: 44-118-921-5800  
Fax: 44-118-921-5820

# Mouser Electronics

Authorized Distributor

Click to View Pricing, Inventory, Delivery & Lifecycle Information:

[Microchip:](#)

[ADM00725](#) [ADM00791](#)