

Aluminum Electrolytic Capacitors

Item Name	Rating	Case size	KNSCHA Lifetime
SHG2E100M-0812	SHG250V10 μ F	Φ 8*12L	10000 hours

1. Operating Temp. Range

-55°C ~ +105°C

2. Electrical Characteristics

See Table 1.

【Table 1】

Rated Voltage VDC	Surge Voltage VDC	Nominal Static Capacitance (μ F)	Tolerance on Capacitance (%) 20°C 120Hz	Dissipation Factor ($\tan \delta$)max 20°C 120Hz	Leakage Current 2min. 20°C (μ A)max	Permissible Ripple Current (mA)rms)max 105°C100KHz	Impedance(Ω) 100KHZ 20°C
250	300	10	-20~+20	0.20	65	280	4.5

3. Dimensions

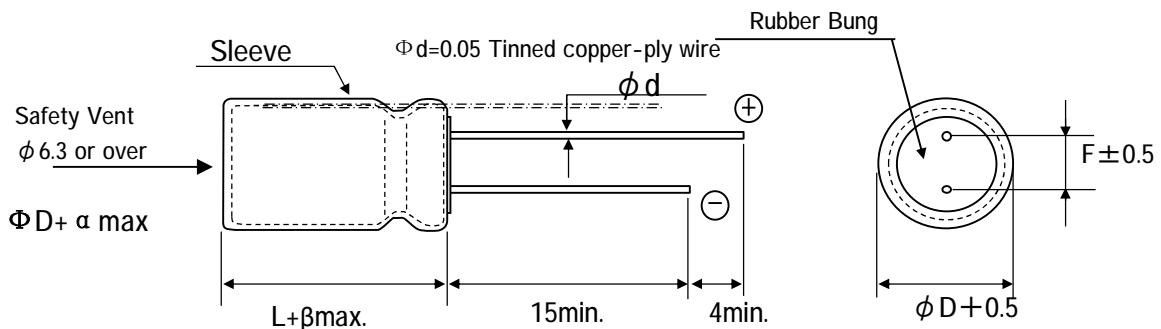

Unit(mm)

ϕ D+0.5Max	L+1Max	F \pm 0.5	d \pm 0.05
8	12	3.5	0.5

4. Marking

Following items are printed with white color on coffee color sleeve

Example of Marking

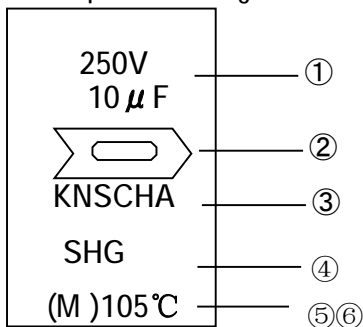

- ① Rated voltage & Nominal Capacitance
- ② Polarity (negative)
- ③ Trade Mark
- ④ series
- ⑤ Symbol of Capacitance Tolerance (M)
- ⑥ Max Operating Temp.

5. MULTIPLIER FOR RIPPLE CURRENT

①. Frequency Coefficient

Freq.(Hz)	60 (50)	120	1K	10K	100K	
Cap(μ F)	0.1-47	0.75	0.80	0.85	0.90	1.00
68-680	0.80	0.85	0.90	0.95	1.00	
1000-22000	0.85	0.87	0.89	0.92	1.00	

②. Temperature Coefficient

Ambient Temperature(°C)	40	60	70	85	105
Coefficient	2.40	2.10	1.78	1.65	1.00

6. Characteristics

No.	Item	Performance	Test Method						
1	Leakage Current	$I = 65.00 \mu A$ ($I = 0.02CV + 15(UA)$) I= Max Leakage Current C=Ctatic Capacitor: V=Rated Voltage	Protection Resistor : $1000 \pm 10 \Omega$ Applied Volt : Rated Voltage Mesasuring time : 2minutes						
2	Static Capacitance	8 ~ 12 μF	Measured Frequency : $120Hz \pm 20\%$ Measured Voltage $\leq 0.5V_{rms}$, 1.5 ~ 2.0VDC						
3	Dissipation Factor (tan δ)	0.20 and Under	Same as condition of Capacitors						
4	High Temp. Load Characteristics	Leakage Current	\leq the value specified in Table 1						
		Cap. Change	$\cong \pm 20\%$ of initial value						
		Dissipation Factor	$\leq 200\%$ of value specified in Table						
		Appearance	No remarkable abnormality						
			Test Temp. : $105 \pm 2^\circ C$ Applied voltage: Rated voltage Test Time :10,000 hours +72, -0 hours						
5	High Temp. no load Characteristics	Leakage Current	\leq the value specified in Table 1						
		Cap. Change	$\cong \pm 20\%$ of initial value						
		Dissipation Factor	$\leq 200\%$ of value specified in Table						
		Appearance	No remarkable abnormality						
			Test Temp. : $105 \pm 2^\circ C$ No voltage applied Test Time :1000 hours +24, -0 hurs						
6	Terminal Strength	Tensile Strength	45N {4.5kg}						
		Bending Strength	25N {2.5kg}						
			Keeping time Tensile 1~5sec Bending 30 \pm 5sec						
7	Impedance Ratio	<table border="1"> <thead> <tr> <th>W V</th> <th>250</th> </tr> </thead> <tbody> <tr> <td>Z-25$^\circ C$/Z+20$^\circ C$</td> <td>4</td> </tr> <tr> <td>Z-40$^\circ C$/Z+20$^\circ C$</td> <td>8</td> </tr> </tbody> </table>	W V	250	Z-25 $^\circ C$ /Z+20 $^\circ C$	4	Z-40 $^\circ C$ /Z+20 $^\circ C$	8	
W V	250								
Z-25 $^\circ C$ /Z+20 $^\circ C$	4								
Z-40 $^\circ C$ /Z+20 $^\circ C$	8								
8	Temperature Charac - teristics	Stage	Item	Performance	Stage	Test Temp($^\circ C$)			
		2,3	Impedance Ratio	less than the value mentioned in 5-7,	1	20 \pm 2			
		5	Cap, Change	$\leq \pm 25\%$ against value in stage 4	2	-25 \pm 3;			
		After the capacitor is held at temperature of each stage and reaches temperature stability, measure performance.			3	-25 \pm 3;			
					4	20 \pm 2			
					5	105 \pm 2			
6	20 \pm 2								
9	Surge Voltage	Item	Perforemance						
		Leakage Current	\leq the initial specified value						
		Cap, Change	$\leq \pm 15\%$ against value before test						
		Dissipation Factor	\leq the initial specified value						
		Appearance	No remakable abnormality						
Test Temp. 15~35 $^\circ C$ Test volt. Surge Volt.Specified in 2 Voltage apply. 1,000times of chage for 30 \pm 5sec, under frequency of 6 \pm 0.5sec, and discharge for 5min30sec.									

6-2. Characteristics

No.	Item	Performance	Test Method								
10	Vibration Resistance	<table border="1"> <tr> <td>Capacitance</td> <td>Stability required</td> </tr> <tr> <td>Cap. Change</td> <td>≤±5% of the initial specified value</td> </tr> <tr> <td>Appearance</td> <td>No remarkable abnormality</td> </tr> </table> <p>Frequency : 10~55Hz/1min. Width of vibration, 1.5mm Direction and duration X, Y and Z directions, each for 2 hours (Total 9 hours)</p>	Capacitance	Stability required	Cap. Change	≤±5% of the initial specified value	Appearance	No remarkable abnormality			
Capacitance	Stability required										
Cap. Change	≤±5% of the initial specified value										
Appearance	No remarkable abnormality										
11	Solderbility	3/4 area of surrounding directions of surface should be covered with new solder.	Solder: Sn-Ag, Sn-Cu Type Soldering Temp : 240±5°C Dipping degree : 2~2.5mm Flux : Ethanol solution (JIS K8101) or Isopropylalcohol (JIS K8839) solution of Rosin (JIS K5902)								
12	Resistance to Soldering	<table border="1"> <tr> <td>Leakage Current</td> <td>≤ Initial specified value</td> </tr> <tr> <td>Cap. Change</td> <td>≤ ±10% of initial value</td> </tr> <tr> <td>Dissipation Factor</td> <td>≤ Initial specified in value</td> </tr> <tr> <td>Appearance</td> <td>No remarkable abnormality</td> </tr> </table>	Leakage Current	≤ Initial specified value	Cap. Change	≤ ±10% of initial value	Dissipation Factor	≤ Initial specified in value	Appearance	No remarkable abnormality	Soldering Temp. 280±5°C Soldering Time . 10±1sec.
Leakage Current	≤ Initial specified value										
Cap. Change	≤ ±10% of initial value										
Dissipation Factor	≤ Initial specified in value										
Appearance	No remarkable abnormality										
13	Resistance to Humidity	<table border="1"> <tr> <td>Leakage Current</td> <td>≤ Initial specified value</td> </tr> <tr> <td>Cap. Change</td> <td>≤ ±15% of initial value</td> </tr> <tr> <td>Dissipation Factor</td> <td>≤ Initial specified value</td> </tr> <tr> <td>Appearance</td> <td>No remarkable abnormality</td> </tr> </table>	Leakage Current	≤ Initial specified value	Cap. Change	≤ ±15% of initial value	Dissipation Factor	≤ Initial specified value	Appearance	No remarkable abnormality	Test Temp. : 40±2°C Humidity 90~95% Test Time : 500 ± 8 hours After the above condition,restored to normal temp, and then measured.
Leakage Current	≤ Initial specified value										
Cap. Change	≤ ±15% of initial value										
Dissipation Factor	≤ Initial specified value										
Appearance	No remarkable abnormality										
14	Perssure valve moment charact-erstics	There must not be thing ignition, scattering the resolution that that case works safely	Dcmethod: impress the reverse voltage and of 1A, I cancel an electric current.								

7 Packing method

Packaging shape, size, quantity

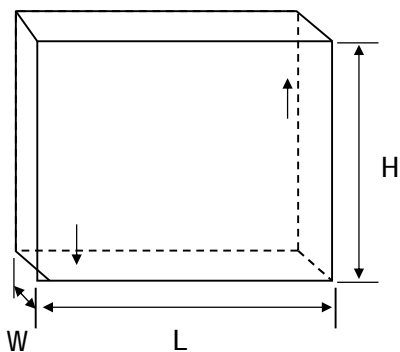

Component size	Quantity per
8*12	16000pcs.

8 Related Standards JIS C 5141

9 Marking on packing box

- ① Item name
- ② Series name
- ③ Rated Voltage
- ④ Nominal Static Capacitance
- ⑤ Case size
- ⑥ Lot No.
- ⑦ Quantity

- 10 Leakage current **<Condition>**
Connecting the capacitor with a protective resistor ($1k\Omega\pm 10\Omega$) in series for 2 minutes, and then, measure leakage current

<Criteria

I : Leakage current (μA)
 $I (\mu A) \leq 0.01CV$ or $3 (\mu A)$ whichever is greater,
 measurement circuit refer to right drawing.
 C: Capacitance (μF)

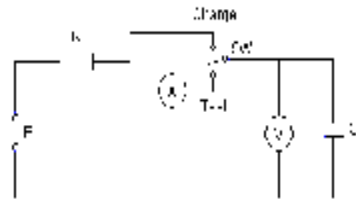

- 11 Soldeing
 11-1 Soldering by soldering iron
 Temperature of iron top : $270\sim 350^{\circ}C$
 Operating time : within 3 sec.
 11-2 Flow soldering.
 Preheat : PCB surface temperature $120^{\circ}C\pm 5^{\circ}C$
 Solder Temp : $260^{\circ}C\pm 5^{\circ}C$
 Solder Dipping Temp. : $2\sim 4$ sec.
- 12 Cleaning of PC board after soldering
 Using following solvents is possible but make sure following condition
 Solvent
 IPA or Alcoholic agent like Pinealpha ST-100S, Cleanthrough 750H, 750L, 710M, 750K, or Technocare FRW-14~17
 ① Cleaning should be made by ultrasonic within 5min, at the temperature less than $60^{\circ}C$.
 ② Control of pollution is necessary (conductivity,pH, specific gravity, water volume)
 ③ Please do not keep near cleaning agent. Please do not store in air-tight container.
 Please let it dry by hot air at the temperature less than maximum operating temp.
- 13 The situation of using
 Please do not use a condenser in the next use environment.
 ① One circumference environment(weatherability) condition.
 (a) Direct water,salt water and environment oil works or become a dew condensation state.
 (b) Environment full of harmful gas (a hydrogen chloride, sulfurous acid, nitrous acid hydrochloric acid, ammonia).
 (c) Ozone, infrared rays and the environment where radioactive rays are done collation of
 ② Vibration shock condition is extreme environment more than rule ranges of delivery specifications.
- 14 A country of origin
 A country of origin of an KNSCHA SHG series alminum electrolysis condenser of specifications:
 China
- 15 Effective life for storage

Storage conditions:

- ① Temperature range must be between $5\sim 35^{\circ}C$
- ② Relative humidity must be less than 75%
- ③ Must be stored indoor
- ④ Must be free from water, oil or salt water
- ⑤ Must be free from toxic gasses (hydrogen sulfide, sulfurous acid, chlorine, ammonium, etc.)
- ⑥ Must be free from ozone, ultraviolet rays or any other radiation
- ⑦ Must be kept in capacitor original package

Aluminum Electrolytic Capacitor SHG Series Structure

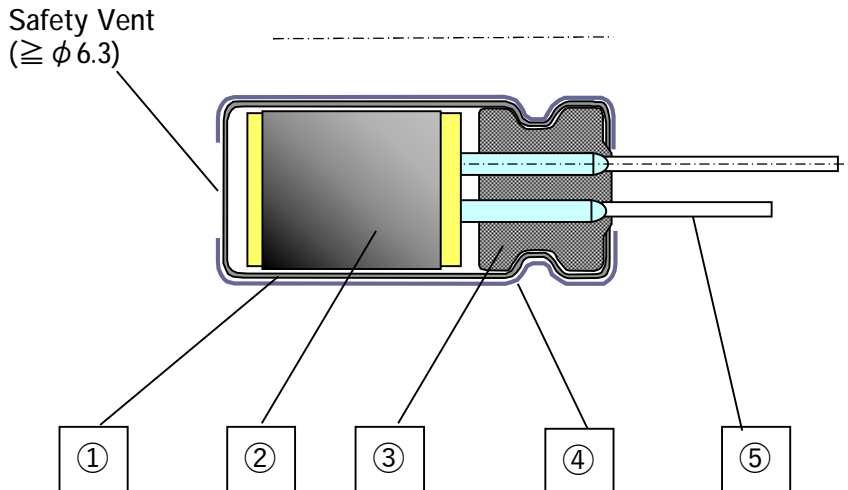

No.	Name	Material
①	Case	Aluminum
②	Element (Electrode)	High Purity Aluminum foil
	(Separator)	Manila hemp pulp
	(Electrolyte)	---
③	Rubber Bung	Synthetic Rubber
④	Sleeve	PET
⑤	Lead Wire	Tin plated Steel Wire

Controls of ozone layer destructive chemical materials

Regulated materials : CFCs, Halon, Carbon Tetrachloride, 1.1.1-Trichloroethane

The products and parts do not include the above materials

The products and parts are not used the above materials on process.

The products and parts are not used PBBOs (Poly Bromo Bi-phenyl Oxides).

All materials are mentioned as existing chemical material in the "Law of examine and control of Production of Chemical Material"

The products are not listed in Appendix 1 of Export Trade Rule and Regulation

A condenser of this series supports RoHS regulation.