

3.3 V ECL Programmable Delay Chip

MC100EP195B

Descriptions

The MC100EP195B is a Programmable Delay Chip (PDC) designed primarily for clock deskewing and timing adjustment. It provides variable delay of a differential NECL/PECL input transition.

The delay section consists of a programmable matrix of gates and multiplexers as shown in the logic diagram, Figure 2. The delay increment of the EP195B has a digitally selectable resolution of about 10 ps and a net range of up to 10.2 ns. The required delay is selected by the 10 data select inputs D[9:0] values and controlled by the LEN (pin 10). A LOW level on LEN allows a transparent LOAD mode of real time delay values by D[9:0]. A LOW to HIGH transition on LEN will LOCK and HOLD current values present against any subsequent changes in D[10:0]. The approximate delay values for varying tap numbers correlating to D0 (LSB) through D9 (MSB) are shown in Table 6 and Figure 3.

The IN/ $\overline{\text{IN}}$ inputs can accept LVPECL (SE of Diff), or LVDS level signals. Because the EP195B is designed using a chain of multiplexers it has a fixed minimum delay of 2.2 ns. An additional pin D10 is provided for controlling Pins 14 and 15, CASCADE and $\overline{\text{CASCADE}}$, also latched by LEN, in cascading multiple PDCs for increased programmable range. The cascade logic allows full control of multiple PDCs. Switching devices from all “1” states on D[0:9] with SETMAX LOW to all “0” states on D[0:9] with SETMAX HIGH will increase the delay equivalent to “D0”, the minimum increment.

Select input pins D[10:0] may be threshold controlled by combinations of interconnects between V_{EF} (pin 7) and V_{CF} (pin 8) for LVC MOS, ECL, or LVTTL level signals. For LVC MOS input levels, leave V_{CF} and V_{EF} open. For ECL operation, short V_{CF} and V_{EF} (Pins 7 and 8). For LVTTL level operation, connect a 1.5 V supply reference to V_{CF} and leave open V_{EF} pin. The 1.5 V reference voltage to V_{CF} pin can be accomplished by placing a 2.2 k Ω resistor between V_{CF} and V_{EE} for a 3.3 V power supply.

The V_{BB} pin, an internally generated voltage supply, is available to this device only. For single-ended input conditions, the unused differential input is connected to V_{BB} as a switching reference voltage. V_{BB} may also rebias AC coupled inputs. When used, decouple V_{BB} and V_{CC} via a 0.01 μF capacitor and limit current sourcing or sinking to 0.5 mA. When not used, V_{BB} should be left open.

The 100 Series contains temperature compensation.

Features

- Maximum Input Clock Frequency >1.2 GHz Typical
- Programmable Range: 0 ns to 10 ns
- Delay Range: 2.2 ns to 12.2 ns
- 10 ps Increments
- PECL Mode Operating Range:
 $V_{\text{CC}} = 3.0 \text{ V to } 3.6 \text{ V with } V_{\text{EE}} = 0 \text{ V}$
- NECL Mode Operating Range:
 $V_{\text{CC}} = 0 \text{ V with } V_{\text{EE}} = -3.0 \text{ V to } -3.6 \text{ V}$

- IN/ $\overline{\text{IN}}$ Inputs Accept LVPECL, LVNECL, LVDS Levels
- A Logic High on the $\overline{\text{EN}}$ Pin Will Force Q to Logic Low
- D[10:0] Can Select Either LVPECL, LVC MOS, or LVTTL Input Levels
- V_{BB} Output Reference Voltage
- These are Pb-Free Devices



ON Semiconductor®

www.onsemi.com

MARKING DIAGRAMS*

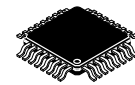

LQFP-32
FA SUFFIX
CASE 561AB

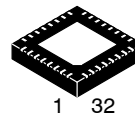
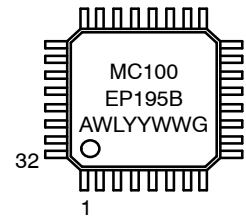

QFN32
MN SUFFIX
CASE 488AM

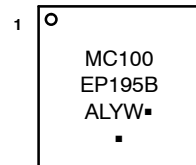

- A = Assembly Location
- WL, L = Wafer Lot
- Y, YY = Year
- W, WW = Work Week
- G or ■ = Pb-Free Package

(Note: Microdot may be in either location)

*For additional marking information, refer to Application Note [AND8002/D](#).

ORDERING INFORMATION

Device	Package	Shipping
MC100EP195BFAG	LQFP-32 (Pb-Free)	250 Units / Tray
MC100EP195BMNG	QFN32 (Pb-Free)	74 Units / Rail

MC100EP195B

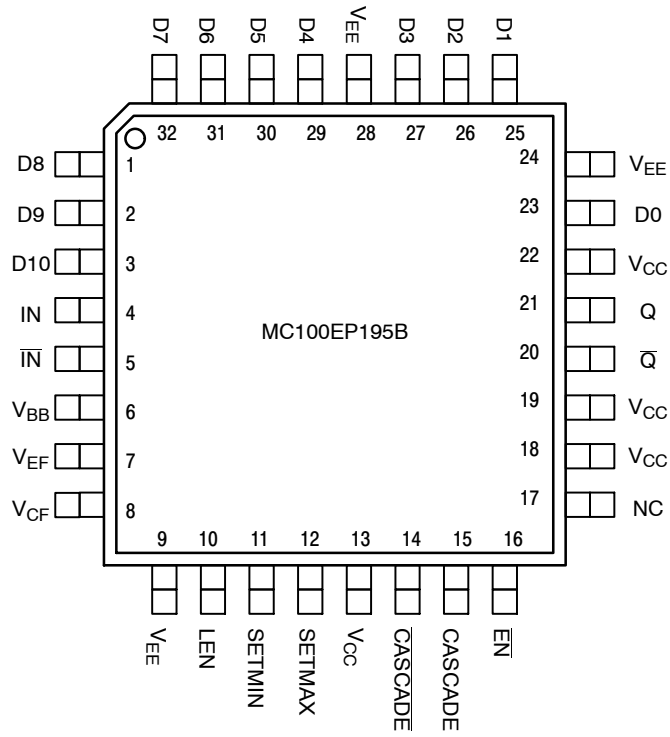

Figure 1. 32-Lead LQFP Pinout (Top View)

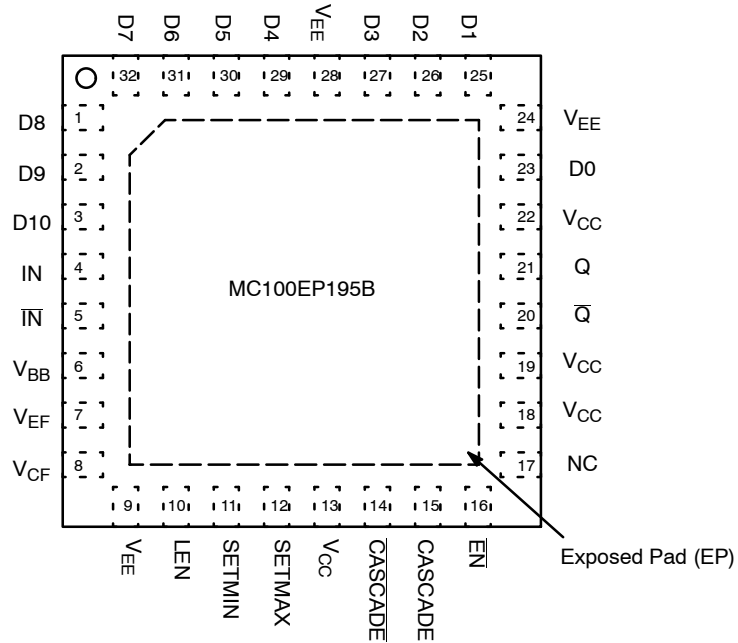

Figure 1. 32-Lead QFN (Top View)

MC100EP195B

Table 1. PIN DESCRIPTION

Pin	Name	I/O	Default State	Description
23, 25, 26, 27, 29, 30, 31, 32, 1, 2	D[0:9]	LVC MOS, LV TTL, ECL Input	Low	Single-Ended Parallel Data Inputs [0:9]. Internal 75 k Ω to V _{EE} . (Note 1)
3	D[10]	LVC MOS, LV TTL, ECL Input	Low	Single-Ended CASCADE/CASCADE \bar{E} Control Input. Internal 75 k Ω to V _{EE} . (Note 1)
4	IN	LVPECL, LVDS	Low	Noninverted Differential Input. Internal 75 k Ω to V _{EE} .
5	\bar{IN}	LVPECL, LVDS	High	Inverted Differential Input. Internal 75 k Ω to V _{EE} and 36.5 k Ω to V _{CC} .
6	V _{BB}	-	-	ECL Reference Voltage Output
7	V _{EF}	-	-	Reference Voltage for ECL Mode Connection
8	V _{CF}	-	-	LVC MOS, ECL, OR LV TTL Input Mode Select
9, 24, 28	V _{EE}	-	-	Negative Supply Voltage. All V _{EE} Pins must be Externally Connected to Power Supply to Guarantee Proper Operation. (Note 2)
13, 18, 19, 22	V _{CC}	-	-	Positive Supply Voltage. All V _{CC} Pins must be externally Connected to Power Supply to Guarantee Proper Operation. (Note 2)
10	LEN	ECL Input	Low	Single-ended D pins LOAD / HOLD input. Internal 75 k Ω to V _{EE} .
11	SETMIN	ECL Input	Low	Single-ended Minimum Delay Set Logic Input. Internal 75 k Ω to V _{EE} . (Note 1)
12	SETMAX	ECL Input	Low	Single-ended Maximum Delay Set Logic Input. Internal 75 k Ω to V _{EE} . (Note 1)
14	$\bar{CASCAD E}$	ECL Output	-	Inverted Differential Cascade Output for D[10]. Typically Terminated with 50 Ω to V _{TT} = V _{CC} - 2 V.
15	CASCADE	ECL Output	-	Noninverted Differential Cascade Output. for D[10] Typically Terminated with 50 Ω to V _{TT} = V _{CC} - 2 V.
16	\bar{EN}	ECL Input	Low	Single-ended Output Enable Pin. Internal 75 k Ω to V _{EE} .
17	NC	-	-	No Connect. The NC Pin is Electrically Connected to the Die and "MUST BE" Left Open
21	Q	ECL Output	-	Noninverted Differential Output. Typically Terminated with 50 Ω to V _{TT} = V _{CC} - 2 V.
20	\bar{Q}	ECL Output	-	Inverted Differential Output. Typically Terminated with 50 Ω to V _{TT} = V _{CC} - 2 V.

1. SETMIN will override SETMAX if both are high. SETMAX and SETMIN will override all D[0:10] inputs.
2. All V_{CC} and V_{EE} pins must be externally connected to Power Supply to guarantee proper operation.

MC100EP195B

Table 2. CONTROL PIN

Pin	State	Function
EN	LOW (Note 3)	Input Signal is Propagated to the Output
	HIGH	Output Holds Logic Low State
LEN	LOW (Note 3)	Transparent or LOAD mode for real time delay values present on D[0:10].
	HIGH	LOCK and HOLD mode for delay values on D[0:10]; further changes on D[0:10] are not recognized and do not affect delay.
SETMIN	LOW (Note 3)	Output Delay set by D[0:10]
	HIGH	Set Minimum Output Delay
SETMAX	LOW (Note 3)	Output Delay set by D[0:10]
	HIGH	Set Maximum Output Delay
D10	LOW (Note 3)	CASCADE Output LOW, CASCADE Output HIGH
	HIGH	CASCADE Output LOW, CASCADE Output HIGH

3. Internal pulldown resistor will provide a logic LOW if pin is left unconnected.

Table 3. CONTROL D[0:10] INTERFACE

V _{CF}	V _{EF} Pin (Note 4)	ECL Mode
V _{CF}	No Connect	LVC MOS Mode
V _{CF}	1.5 V ±100 mV	LVTTTL Mode (Note 5)

4. Short V_{CF} (pin 8) and V_{EF} (pin 7).

5. When Operating in LVTTTL Mode, the reference voltage can be provided by connecting an external resistor, R_{CF} (suggested resistor value is 2.2 kΩ ± 5%), between V_{CF} and V_{EE} pins.

Table 4. DATA INPUT ALLOWED OPERATING VOLTAGE MODE TABLE

POWER SUPPLY	CONTROL DATA SELECT INPUTS PINS (D [0:10])			
	LVC MOS	LVTTTL	LVPECL	LVNECL
PECL Mode Operating Range	YES	YES	YES	N/A
NECL Mode Operating Range	N/A	N/A	N/A	YES

Table 5. ATTRIBUTES

Characteristics	Value
Internal Input Pulldown Resistor (R1)	75 kΩ
ESD Protection Human Body Model Machine Model Charged Device Model	> 2 kV > 100 V > 2 kV
Moisture Sensitivity, Indefinite Time Out of Drypack (Note 6)	Pb-Free Pkg
QFN-32 LQFP-32	Level 1 Level 2
Flammability Rating Oxygen Index: 28 to 34	UL 94 V-0 @ 0.125 in
Transistor Count	1217 Devices
Meets or exceeds JEDEC Spec EIA/JESD78 IC Latchup Test	

6. For additional information, see Application Note [AND8003/D](#).

MC100EP195B

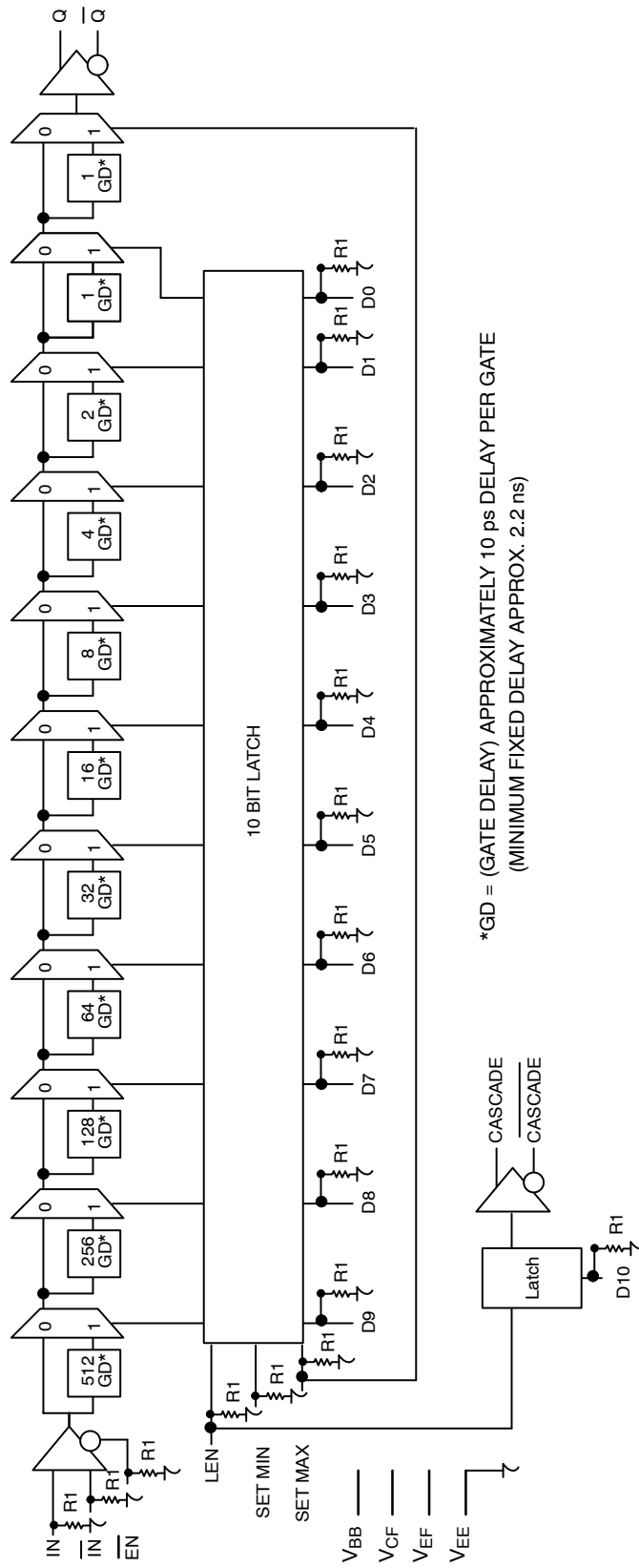

Figure 2. Logic Diagram

MC100EP195B

Table 6. THEORETICAL DELAY VALUES

D(9:0) Value	SETMIN	SETMAX	Programmable Delay*
XXXXXXXXXX	H	L	0 ps
000000000	L	L	0 ps
000000001	L	L	10 ps
000000010	L	L	20 ps
000000011	L	L	30 ps
000000100	L	L	40 ps
000000101	L	L	50 ps
000000110	L	L	60 ps
000000111	L	L	70 ps
000001000	L	L	80 ps
000010000	L	L	160 ps
000100000	L	L	320 ps
001000000	L	L	640 ps
010000000	L	L	1280 ps
100000000	L	L	5120 ps
111111111	L	L	10230 ps
XXXXXXXXXX	L	H	10240 ps

*Fixed minimum delay not included.

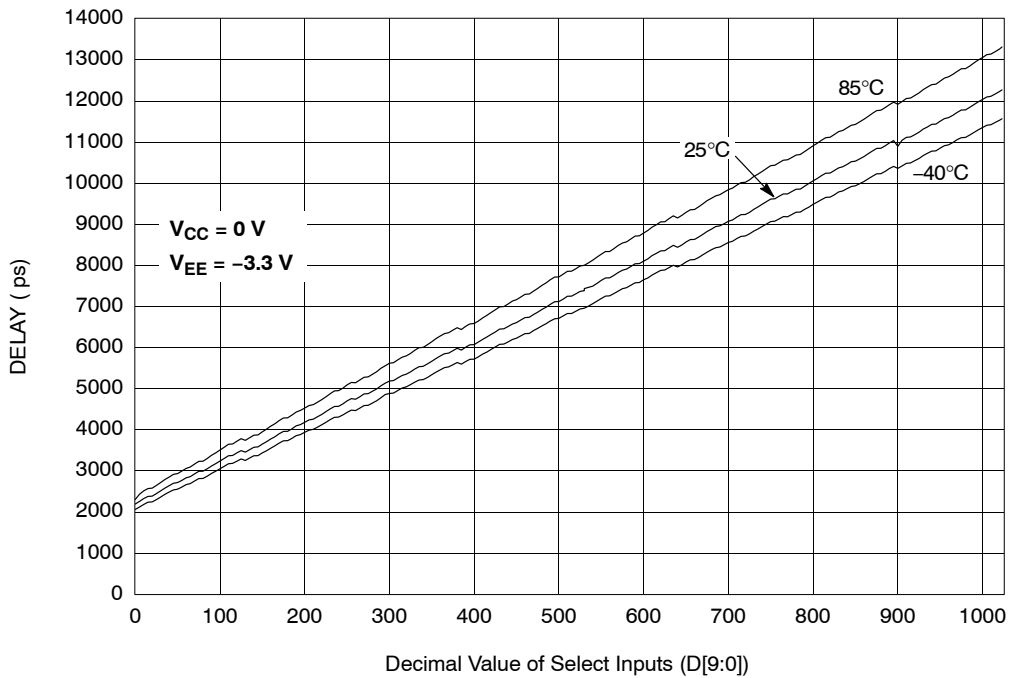

Figure 3. Measured Delay vs. Select Inputs

MC100EP195B

Table 7. MAXIMUM RATINGS

Symbol	Parameter	Condition 1	Condition 2	Rating	Unit
V _{CC}	Positive Mode Power Supply	V _{EE} = 0 V		6	V
V _{EE}	Negative Mode Power Supply	V _{CC} = 0 V		-6	V
V _I	Positive Mode Input Voltage Negative Mode Input Voltage	V _{EE} = 0 V V _{CC} = 0 V	V _I ≤ V _{CC} V _I ≥ V _{EE}	6 -6	V V
I _{out}	Output Current	Continuous Surge		50 100	mA mA
I _{BB}	V _{BB} Sink/Source			±0.5	mA
T _A	Operating Temperature Range			-40 to +85	°C
T _{stg}	Storage Temperature Range			-65 to +150	°C
θ _{JA}	Thermal Resistance (Junction-to-Ambient)	0 lfpm 500 lfpm	QFN-32 QFN-32	31 27	°C/W °C/W
θ _{JC}	Thermal Resistance (Junction-to-Case)	2S2P Standard Board	QFN-32	12	°C/W
θ _{JA}	Thermal Resistance (Junction-to-Ambient)	0 lfpm 500 lfpm	LQFP-32 LQFP-32	80 55	°C/W °C/W
θ _{JC}	Thermal Resistance (Junction-to-Case)	2S2P Standard Board	LQFP-32	12 to 17	°C/W
T _{sol}	Wave Solder	<2 to 3 sec @ 260°C		265	°C

Stresses exceeding those listed in the Maximum Ratings table may damage the device. If any of these limits are exceeded, device functionality should not be assumed, damage may occur and reliability may be affected.

Table 8. 100EP DC CHARACTERISTICS, PECL (V_{CC} = 3.3 V, V_{EE} = 0 V) (Note 7)

Symbol	Characteristic	-40°C			25°C			85°C			Unit
		Min	Typ	Max	Min	Typ	Max	Min	Typ	Max	
I _{EE}	Negative Power Supply Current	90	115	170	100	140	170	100	145	170	mA
V _{OH}	Output HIGH Voltage (Note 8)	2155	2280	2405	2155	2280	2405	2155	2280	2405	mV
V _{OL}	Output LOW Voltage (Note 8)	1305	1480	1605	1305	1480	1605	1305	1480	1605	mV
V _{IH}	Input HIGH Voltage (Single-Ended) LVPECL CMOS TTL	2075 2000 2000		2420 3300 3300	2075 2000 2000		2420 3300 3300	2075 2000 2000		2420 3300 3300	mV
V _{IL}	Input LOW Voltage (Single-Ended) LVPECL CMOS TTL	1305 0 0		1675 800 800	1305 0 0		1675 800 800	1305 0 0		1675 800 800	mV
V _{BB}	ECL Output Voltage Reference	1775	1875	1975	1775	1875	1975	1775	1875	1975	mV
V _{CF}	LVTTTL Mode Input Detect Voltage	1.4	1.5	1.6	1.4	1.5	1.6	1.4	1.5	1.6	V
V _{EF}	Reference Voltage for ECL Mode Connection	1900	2020	2150	1900	2020	2150	1900	2020	2150	mV
V _{IHCMR}	Input HIGH Voltage Common Mode Range (Differential Configuration) (Note 9)	1.2		3.3	1.2		3.3	1.2		3.3	V
I _{IH}	Input HIGH Current (@ V _{IH})	0		150	0		150	0		150	μA
I _{IL}	Input LOW Current (@ V _{IL})	0		150	0		150	0		150	μA

NOTE: Device will meet the specifications after thermal equilibrium has been established when mounted in a test socket or printed circuit board with maintained transverse airflow greater than 500 lfpm.

7. Input and output parameters vary 1:1 with V_{CC}. V_{EE} can vary +0.3 V to -0.3 V.

8. All loading with 50 Ω to V_{CC} - 2.0 V.

9. V_{IHCMR} min varies 1:1 with V_{EE}. V_{IHCMR} max varies 1:1 with V_{CC}. The V_{IHCMR} range is referenced to the most positive side of the differential input signal.

MC100EP195B

Table 9. 100EP DC CHARACTERISTICS, NECL ($V_{CC} = 0\text{ V}$, $V_{EE} = -3.3\text{ V}$) (Note 10)

Symbol	Characteristic	-40°C			25°C			85°C			Unit
		Min	Typ	Max	Min	Typ	Max	Min	Typ	Max	
I_{EE}	Negative Power Supply Current (Note 11)	90	115	170	100	140	170	100	145	170	mA
V_{OH}	Output HIGH Voltage (Note 12)	-1145	-1020	-895	-1145	-1020	-895	-1145	-1020	-895	mV
V_{OL}	Output LOW Voltage (Note 12)	-1995	-1820	-1695	-1995	-1820	-1695	-1995	-1820	-1695	mV
V_{IH}	Input HIGH Voltage (Single-Ended) LVNECL	-1225		-880	-1225		-880	-1225		-880	mV
V_{IL}	Input LOW Voltage (Single-Ended) LVNECL	-1995		-1625	-1995		-1625	-1995		-1625	mV
V_{BB}	ECL Output Voltage Reference	-1525	-1425	-1325	-1525	-1425	-1325	-1525	-1425	-1325	mV
V_{EF}	Reference Voltage for ECL Mode Connection	-1400	-1280	-1250	-1400	-1280	-1250	-1400	-1280	-1250	mV
V_{IHCMR}	Input HIGH Voltage Common Mode Range (Differential Configuration) (Note 13)	$V_{EE} + 1.2$		0.0	$V_{EE} + 1.2$		0.0	$V_{EE} + 1.2$		0.0	V
I_{IH}	Input HIGH Current (@ V_{IH})	0		150	0		150	0		150	μA
I_{IL}	Input LOW Current (@ V_{IL})	0		150	0		150	0		150	μA

NOTE: Device will meet the specifications after thermal equilibrium has been established when mounted in a test socket or printed circuit board with maintained transverse airflow greater than 500 lfpm.

10. Input and output parameters vary 1:1 with V_{CC} . V_{EE} can vary +0.3 V to -0.3 V.

11. Required 500 lfpm air flow when using +5 V power supply. For $(V_{CC} - V_{EE}) > 3.3\text{ V}$, 5 Ω to 10 Ω in line with V_{EE} required for maximum thermal protection at elevated temperatures. Recommend $V_{CC} - V_{EE}$ operation at $\leq 3.8\text{ V}$.

12. All loading with 50 Ω to $V_{CC} - 2.0\text{ V}$.

13. V_{IHCMR} min varies 1:1 with V_{EE} . V_{IHCMR} max varies 1:1 with V_{CC} . The V_{IHCMR} range is referenced to the most positive side of the differential input signal.

Table 10. AC CHARACTERISTICS ($V_{CC} = 0\text{ V}$; $V_{EE} = -3.0\text{ V}$ to -3.6 V or $V_{CC} = 3.0\text{ V}$ to 3.6 V ; $V_{EE} = 0\text{ V}$) (Note 14)

Symbol	Characteristic	-40°C			25°C			85°C			Unit
		Min	Typ	Max	Min	Typ	Max	Min	Typ	Max	
f_{max}	Maximum Frequency		1.2			1.2			1.2		GHz
V_{outPP}	Output Voltage Amplitude	610	820		610	820		610	820		mV
t_{PLH} t_{PHL}	Propagation Delay IN to Q; D(0-10) = 0, SETMIN IN to Q; D(0-10) = 1023, SETMAX \overline{EN} to Q; D(0-10) = 0 D0 to CASCADE	2000 10900 1990 375	2400 12400 2500 475	2800 13900 2990 575	2150 11500 2130 400	2500 13000 2600 500	2950 14500 3130 600	2250 12250 2380 425	2700 13750 2800 525	3050 15250 3380 625	ps
t_{RANGE}	Programmable Range $t_{PD}(\text{max}) - t_{PD}(\text{min})$	8950	9950	10950	9450	10450	11450	10110	11100	12110	ps

NOTE: Device will meet the specifications after thermal equilibrium has been established when mounted in a test socket or printed circuit board with maintained transverse airflow greater than 500 lfpm.

14. Measured using a 750 mV source, 50% duty cycle clock source. All loading with 50 Ω to $V_{CC} - 2.0\text{ V}$.

15. Specification limits represent the amount of delay added with the assertion of each individual delay control pin. The various combinations of asserted delay control inputs will typically realize D0 resolution steps across the specified programmable range.

16. Duty cycle skew guaranteed only for differential operation measured from the cross point of the input to the cross point of the output.

17. This setup time defines the amount of time prior to the input signal the delay tap of the device must be set.

18. This setup time is the minimum time that \overline{EN} must be asserted prior to the next transition of IN/ \overline{IN} to prevent an output response greater than $\pm 75\text{ mV}$ to that IN/ \overline{IN} transition.

19. This hold time is the minimum time that \overline{EN} must remain asserted after a negative going IN or positive going \overline{IN} to prevent an output response greater than $\pm 75\text{ mV}$ to that IN/ \overline{IN} transition.

20. This release time is the minimum time that \overline{EN} must be deasserted prior to the next IN/ \overline{IN} transition to ensure an output response that meets the specified IN to Q propagation delay and transition times.

21. Deviation from a linear delay (actual Min to Max) in the 1024 programmable steps.

MC100EP195B

Table 10. AC CHARACTERISTICS ($V_{CC} = 0\text{ V}$; $V_{EE} = -3.0\text{ V}$ to -3.6 V or $V_{CC} = 3.0\text{ V}$ to 3.6 V ; $V_{EE} = 0\text{ V}$) (Note 14) (continued)

Symbol	Characteristic	-40°C			25°C			85°C			Unit
		Min	Typ	Max	Min	Typ	Max	Min	Typ	Max	
Δt	Step Delay (Note 15)										ps
	D0 High		10			11				15	
	D1 High		16			18				26	
	D2 High		32			33				46	
	D3 High		65			72				92	
	D4 High		155			165				195	
	D5 High		310			325				370	
	D6 High		620			650				720	
	D7 High		1200			1300				1400	
D8 High		2500			2600				2800		
D9 High		4900			5200				5500		
NLIN	Non-Linearity (Note 21)										ps
	0 to 511 Decimal Values for D[9:0] Range		± 7.0			± 7.0			± 11		
	512 to 1024 Decimal Values for D[9:0] Range		± 7.0			± 7.0			± 11		
	1 to 1023 Decimal Values for D[9:0] Range		± 11			± 11			± 18		
t_{SKEW}	Duty Cycle Skew (Note 16) $ t_{PHL} - t_{PLH} $		25	90		25	90		25	90	ps
t_s	Setup Time										ps
	D to LEN	200	-40		200	-40		200	-40		
	D to IN (Note 17)	500	-550		500	-590		500	-650		
	EN to IN (Note 18)	300	100		300	100		300	120		
t_h	Hold Time										ps
	LEN to D IN to \overline{EN} (Note 19)	200 400	50 -320		200 400	40 -350		200 400	30 -400		
t_R	Release Time										ps
	\overline{EN} to IN (Note 20)	300	-150		300	-170		300	-200		
	SET MAX to LEN	400	180		400	200		400	210		
	SET MIN to LEN	350	220		350	250		350	260		
t_{jitter}	RMS Random Clock Jitter @ 1.2 GHz										ps
	IN to Q; D(0:10) = 0 or SETMIN IN to Q; D(0:10) = 1023 or SETMAX		0.9 1.9	2.0 5.0		1.1 2.6	2.0 5.0		1.2 3.3	2.0 5.0	
V_{PP}	Input Voltage Swing (Differential Configuration)	150	800	1200	150	800	1200	150	800	1200	mV
t_r t_f	Output Rise/Fall Time @ 50 MHz										ps
	20-80% (Q)	85	115	140	100	120	140	100	130	165	
	20-80% (CASCADE)	110	160	210	120	175	230	120	190	250	

NOTE: Device will meet the specifications after thermal equilibrium has been established when mounted in a test socket or printed circuit board with maintained transverse airflow greater than 500 lfm.

14. Measured using a 750 mV source, 50% duty cycle clock source. All loading with $50\ \Omega$ to $V_{CC} - 2.0\text{ V}$.

15. Specification limits represent the amount of delay added with the assertion of each individual delay control pin. The various combinations of asserted delay control inputs will typically realize D0 resolution steps across the specified programmable range.

16. Duty cycle skew guaranteed only for differential operation measured from the cross point of the input to the cross point of the output.

17. This setup time defines the amount of time prior to the input signal the delay tap of the device must be set.

18. This setup time is the minimum time that \overline{EN} must be asserted prior to the next transition of IN/ \overline{IN} to prevent an output response greater than $\pm 75\text{ mV}$ to that IN/ \overline{IN} transition.

19. This hold time is the minimum time that \overline{EN} must remain asserted after a negative going IN or positive going \overline{IN} to prevent an output response greater than $\pm 75\text{ mV}$ to that IN/ \overline{IN} transition.

20. This release time is the minimum time that \overline{EN} must be deasserted prior to the next IN/ \overline{IN} transition to ensure an output response that meets the specified IN to Q propagation delay and transition times.

21. Deviation from a linear delay (actual Min to Max) in the 1024 programmable steps.

MC100EP195B

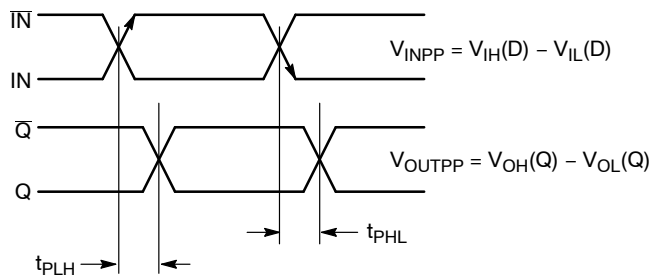

Figure 4. AC Reference Measurement

Cascading Multiple EP195Bs

To increase the programmable range of the EP195B, internal cascade circuitry has been included. This circuitry allows for the cascading of multiple EP195Bs without the need for any external gating. Furthermore, this capability requires only one more address line per added EP195B. Obviously, cascading multiple programmable delay chips will result in a larger programmable range; however, this increase is at the expense of a longer minimum delay.

Figure 5 illustrates the interconnect scheme for cascading two EP195Bs. As can be seen, this scheme can easily be

expanded for larger EP195B chains. The D10 input of the EP195B is the CASCADE control pin. With the interconnect scheme of Figure 5 when D10 is asserted, it signals the need for a larger programmable range than is achievable with a single device and switches output pin CASCADE HIGH and pin $\overline{\text{CASCADE}}$ LOW. The A11 address can be added to generate a cascade output for the next EP195B. For a 2-device configuration, A11 is not required.

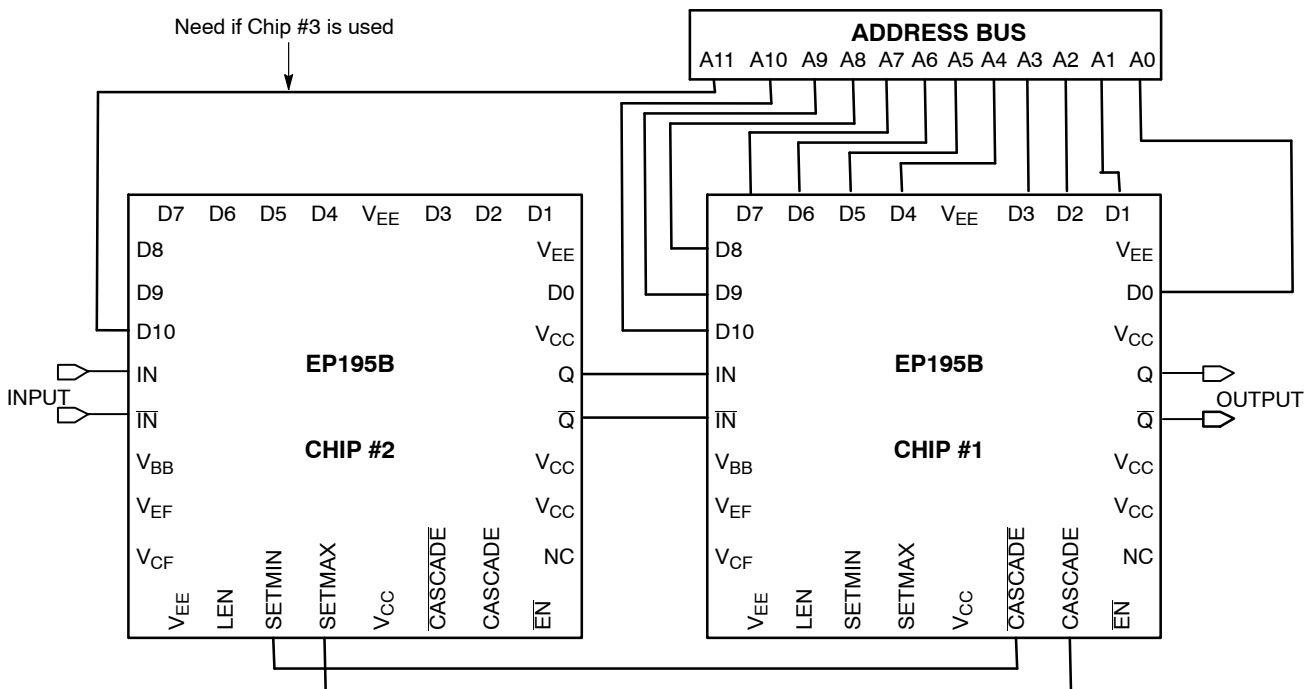

Figure 5. Cascading Interconnect Architecture

An expansion of the latch section of the block diagram is pictured in Figure 6. Use of this diagram will simplify the explanation of how the cascade circuitry works. When D10 of chip #1 in Figure 5 is LOW this device's CASCADE output will also be low while the $\overline{\text{CASCADE}}$ output will be high. In this condition the SET MIN pin of chip #2 will be asserted HIGH and thus all of the latches of

chip #2 will be reset and the device will be set at its minimum delay.

Chip #1, on the other hand, will have both SET MIN and SET MAX deasserted so that its delay will be controlled entirely by the address bus A0—A9. If the delay needed is greater than can be achieved with 1023 gate delays (111111111 on the A0—A9 address bus) D10 will be

MC100EP195B

asserted to signal the need to cascade the delay to the next EP195B device. When D10 is asserted, the SET MIN pin of chip #2 will be deasserted and SET MAX pin asserted resulting in the device delay to be the maximum delay. Table 11 shows the delay time of two EP195B chips in cascade.

To expand this cascading scheme to more devices, one simply needs to connect the D10 pin from the next chip to the address bus and CASCADE outputs to the next chip in the same manner as pictured in Figure 5. The only addition to the logic is the increase of one line to the address bus for cascade control of the second programmable delay chip.

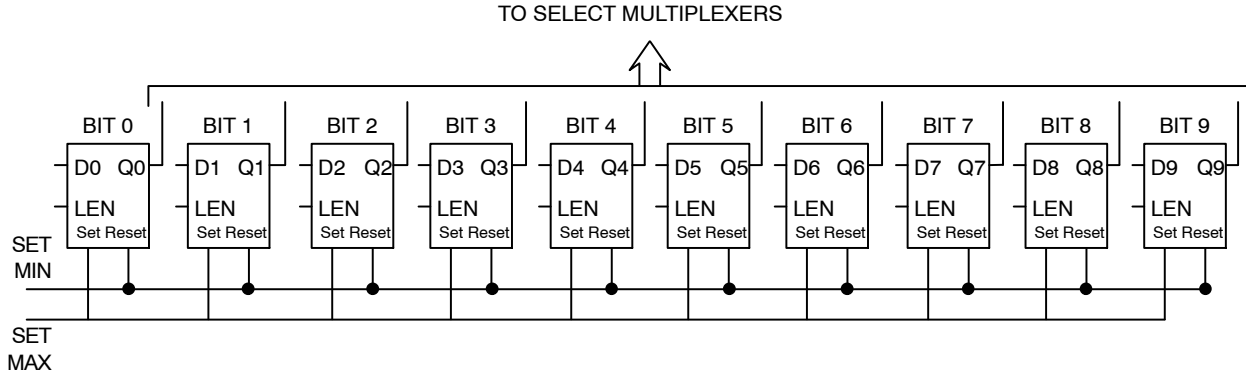

Figure 6. Expansion of the Latch Section of the EP195B Block Diagram

MC100EP195B

Table 11. Delay Value of Two EP195B Cascaded

VARIABLE INPUT TO CHIP #1 AND SETMIN FOR CHIP #2												
INPUT FOR CHIP #1												Total
D10	D9	D8	D7	D6	D5	D4	D3	D2	D1	D0	Delay Value	Delay Value
0	0	0	0	0	0	0	0	0	0	0	0 ps	4400 ps
0	0	0	0	0	0	0	0	0	0	1	10 ps	4410 ps
0	0	0	0	0	0	0	0	0	1	0	20 ps	4420 ps
0	0	0	0	0	0	0	0	0	1	1	30 ps	4430 ps
0	0	0	0	0	0	0	0	1	0	0	40 ps	4440 ps
0	0	0	0	0	0	0	0	1	0	1	50 ps	4450 ps
0	0	0	0	0	0	0	0	1	1	0	60 ps	4460 ps
0	0	0	0	0	0	0	0	1	1	1	70 ps	4470 ps
0	0	0	0	0	0	0	1	0	0	0	80 ps	4480 ps
0	0	0	0	0	0	1	0	0	0	0	160 ps	4560 ps
0	0	0	0	0	1	0	0	0	0	0	220 ps	4720 ps
0	0	0	0	1	0	0	0	0	0	0	640 ps	5040 ps
0	0	0	1	0	0	0	0	0	0	0	1280 ps	5680 ps
0	0	1	0	0	0	0	0	0	0	0	2560 ps	6960 ps
0	1	0	0	0	0	0	0	0	0	0	5120 ps	9520 ps
0	1	1	1	1	1	1	1	1	1	1	10230 ps	14630 ps

VARIABLE INPUT TO CHIP #1 AND SETMAX FOR CHIP #2												
INPUT FOR CHIP #1												Total
D10	D9	D8	D7	D6	D5	D4	D3	D2	D1	D0	Delay Value	Delay Value
1	0	0	0	0	0	0	0	0	0	0	10240 ps	14640 ps
1	0	0	0	0	0	0	0	0	0	1	10250 ps	14650 ps
1	0	0	0	0	0	0	0	0	1	0	10260 ps	14660 ps
1	0	0	0	0	0	0	0	0	1	1	10270 ps	14670 ps
1	0	0	0	0	0	0	0	1	0	0	10280 ps	14680 ps
1	0	0	0	0	0	0	0	1	0	1	10290 ps	14690 ps
1	0	0	0	0	0	0	0	1	1	0	10300 ps	14700 ps
1	0	0	0	0	0	0	0	1	1	1	10310 ps	14710 ps
1	0	0	0	0	0	0	1	0	0	0	10320 ps	14720 ps
1	0	0	0	0	0	1	0	0	0	0	10400 ps	14800 ps
1	0	0	0	0	1	0	0	0	0	0	10560 ps	14960 ps
1	0	0	0	1	0	0	0	0	0	0	10880 ps	15280 ps
1	0	0	1	0	0	0	0	0	0	0	11520 ps	15920 ps
1	0	1	0	0	0	0	0	0	0	0	12800 ps	17200 ps
1	1	0	0	0	0	0	0	0	0	0	15360 ps	19760 ps
1	1	1	1	1	1	1	1	1	1	1	20470 ps	24870 ps

MC100EP195B

Multi-Channel Deskewing

The most practical application for EP195B is in multiple channel delay matching. Slight differences in impedance and cable length can create large timing skews within a high-speed system. To deskew multiple signal channels, each channel can

be sent through each EP195B as shown in Figure 7. One signal channel can be used as reference and the other EP195Bs can be used to adjust the delay to eliminate the timing skews. Nearly any high-speed system can be fine-tuned (as small as 10 ps) to reduce the skew to extremely tight tolerances.

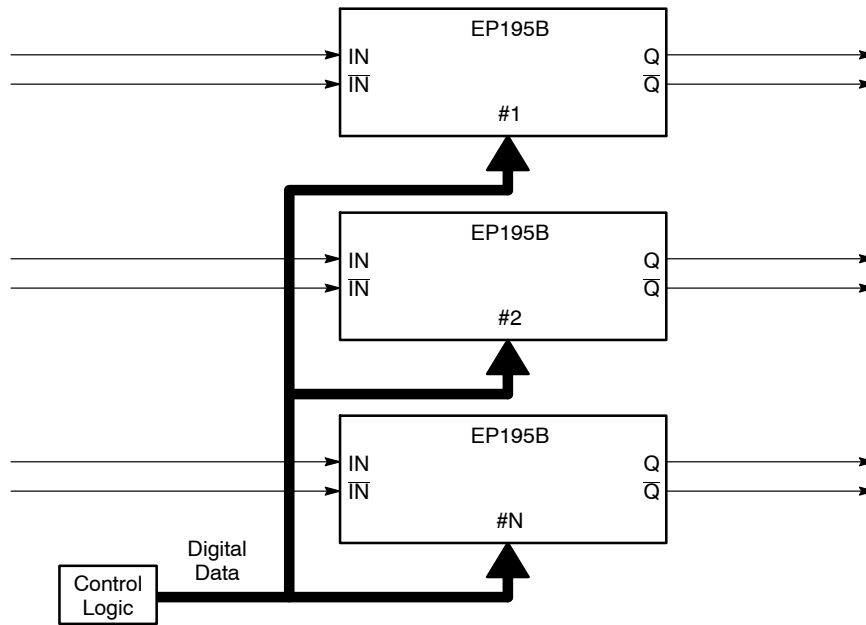

Figure 7. Multiple Channel Deskewing Diagram

Measure Unknown High Speed Device Delays

EP195Bs provide a possible solution to measure the unknown delay of a device with a high degree of precision. By combining two EP195Bs and EP31 as shown in Figure 8, the delay can be measured. The first EP195B can be set to SETMIN and its output is used to drive the unknown delay device, which in turn drives the input of a D flip-flop of EP31. The second EP195B is triggered along with the first EP195B and its output provides a clock signal for EP31. The programmed delay of the second EP195B is varied to detect the output edge from the unknown delay device.

If the programmed delay through the second EP195B is too long, the flip-flop output will be at logic high. On the other hand, if the programmed delay through the second EP195B is too short, the flip-flop output will be at a logic low. If the programmed delay is correctly fine-tuned in the second EP195B, the flip-flop will bounce between logic high and logic low. The digital code in the second EP195B can be directly correlated into an accurate device delay.

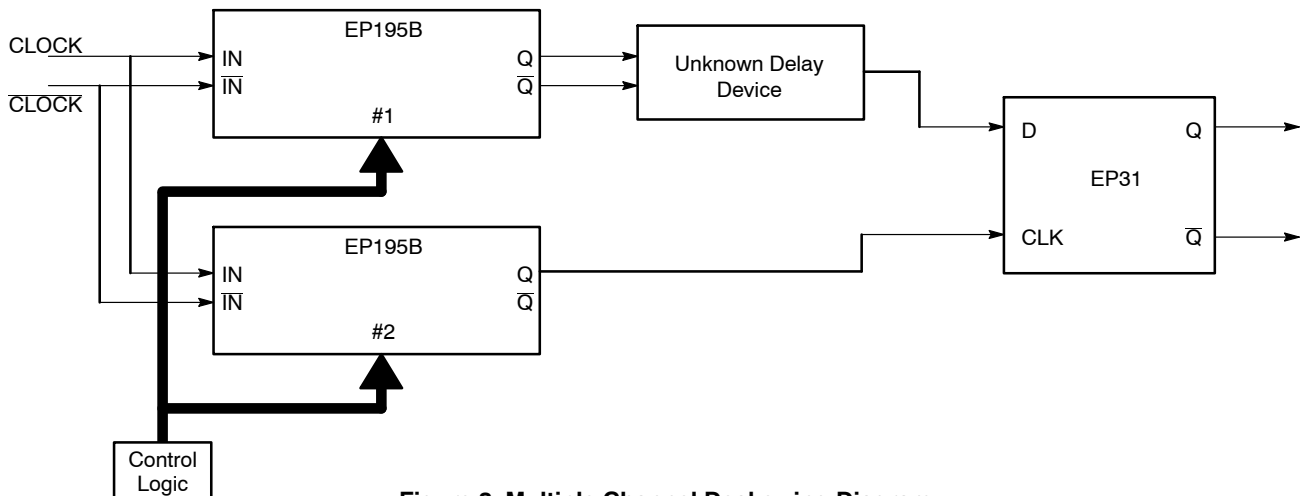
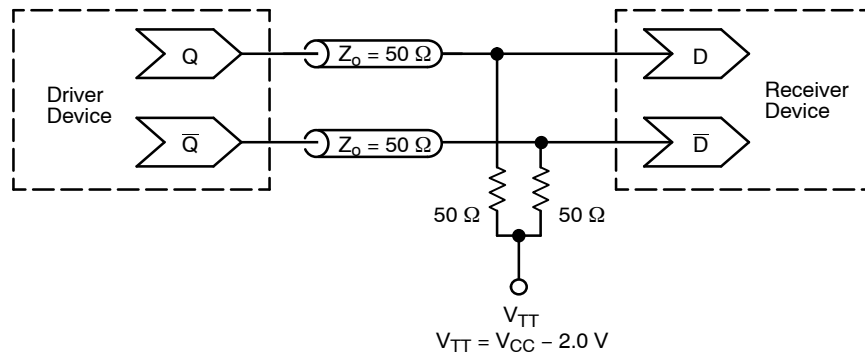

Figure 8. Multiple Channel Deskewing Diagram

MC100EP195B



**Figure 9. Typical Termination for Output Driver and Device Evaluation
(See Application Note AND8020/D – Termination of ECL Logic Devices.)**

Resource Reference of Application Notes

- AN1405/D** – ECL Clock Distribution Techniques
- AN1406/D** – Designing with PECL (ECL at +5.0 V)
- AN1503/D** – ECLinPS™ I/O SPiCE Modeling Kit
- AN1504/D** – Metastability and the ECLinPS Family
- AN1568/D** – Interfacing Between LVDS and ECL
- AN1642/D** – The ECL Translator Guide
- AND8001/D** – Odd Number Counters Design
- AND8002/D** – Marking and Date Codes
- AND8020/D** – Termination of ECL Logic Devices
- AND8066/D** – Interfacing with ECLinPS
- AND8090/D** – AC Characteristics of ECL Devices

MECHANICAL CASE OUTLINE

PACKAGE DIMENSIONS

ON Semiconductor®

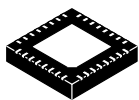

1 32

SCALE 2:1

QFN32 5x5, 0.5P
CASE 488AM
ISSUE A

DATE 23 OCT 2013

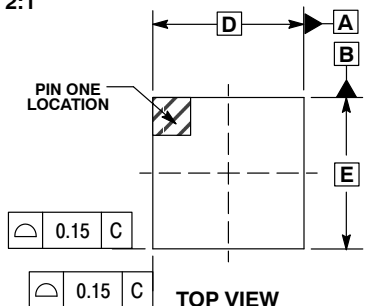

TOP VIEW

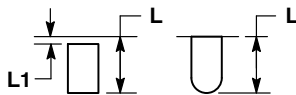

DETAIL A
ALTERNATE TERMINAL
CONSTRUCTIONS

NOTES:

1. DIMENSIONS AND TOLERANCING PER ASME Y14.5M, 1994.
2. CONTROLLING DIMENSION: MILLIMETERS.
3. DIMENSION b APPLIES TO PLATED TERMINAL AND IS MEASURED BETWEEN 0.15 AND 0.30MM FROM THE TERMINAL TIP. COPLANARITY APPLIES TO THE EXPOSED PAD AS WELL AS THE TERMINALS.
4. COPLANARITY APPLIES TO THE EXPOSED PAD AS WELL AS THE TERMINALS.

MILLIMETERS		
DIM	MIN	MAX
A	0.80	1.00
A1	---	0.05
A3	0.20	REF
b	0.18	0.30
D	5.00	BSC
D2	2.95	3.25
E	5.00	BSC
E2	2.95	3.25
e	0.50	BSC
K	0.20	---
L	0.30	0.50
L1	---	0.15

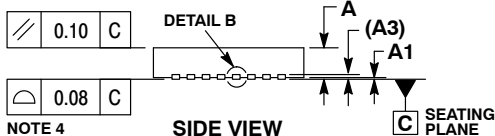

SIDE VIEW

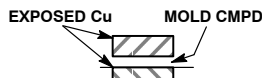

DETAIL B
ALTERNATE
CONSTRUCTION

GENERIC
MARKING DIAGRAM*

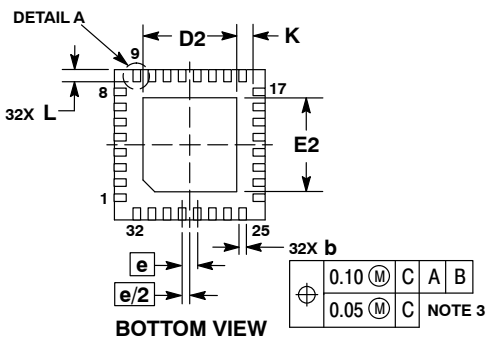

BOTTOM VIEW

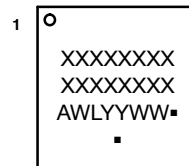

- XXXXXX = Specific Device Code
- A = Assembly Location
- WL = Wafer Lot
- YY = Year
- WW = Work Week
- = Pb-Free Package

(Note: Microdot may be in either location)
*This information is generic. Please refer to device data sheet for actual part marking.
Pb-Free indicator, "G" or microdot "▪", may or may not be present.

RECOMMENDED
SOLDERING FOOTPRINT*

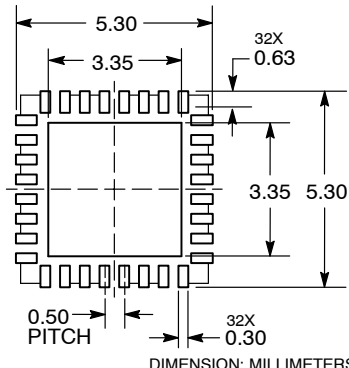

DIMENSION: MILLIMETERS

*For additional information on our Pb-Free strategy and soldering details, please download the ON Semiconductor Soldering and Mounting Techniques Reference Manual, SOLDERRM/D.

DOCUMENT NUMBER:	98AON20032D	Electronic versions are uncontrolled except when accessed directly from the Document Repository. Printed versions are uncontrolled except when stamped "CONTROLLED COPY" in red.
DESCRIPTION:	QFN32 5x5 0.5P	PAGE 1 OF 1

ON Semiconductor and ON are trademarks of Semiconductor Components Industries, LLC dba ON Semiconductor or its subsidiaries in the United States and/or other countries. ON Semiconductor reserves the right to make changes without further notice to any products herein. ON Semiconductor makes no warranty, representation or guarantee regarding the suitability of its products for any particular purpose, nor does ON Semiconductor assume any liability arising out of the application or use of any product or circuit, and specifically disclaims any and all liability, including without limitation special, consequential or incidental damages. ON Semiconductor does not convey any license under its patent rights nor the rights of others.

MECHANICAL CASE OUTLINE
PACKAGE DIMENSIONS

ON Semiconductor®



LQFP-32, 7x7
CASE 561AB-01
ISSUE O

DATE 19 JUN 2008



SYMBOL	MIN	NOM	MAX
A	—	—	1.60
A1	0.05	—	0.15
A2	1.35	1.40	1.45
B	0.30	0.37	0.45
B1	0.30	0.35	0.40
C	0.09	—	0.20
C1	0.09	—	0.16
D	9.00 BSC		
D1	7.00 BSC		
E	9.00 BSC		
E1	7.00 BSC		
e	0.80 BSC		
L	0.45	0.60	0.75
L1	1.00		
R1	0.08	—	0.20
α°	11	—	13
β°	0	—	7
γ°	0	—	—

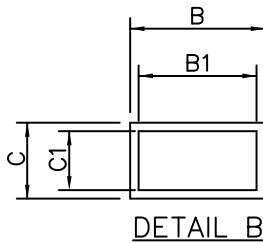
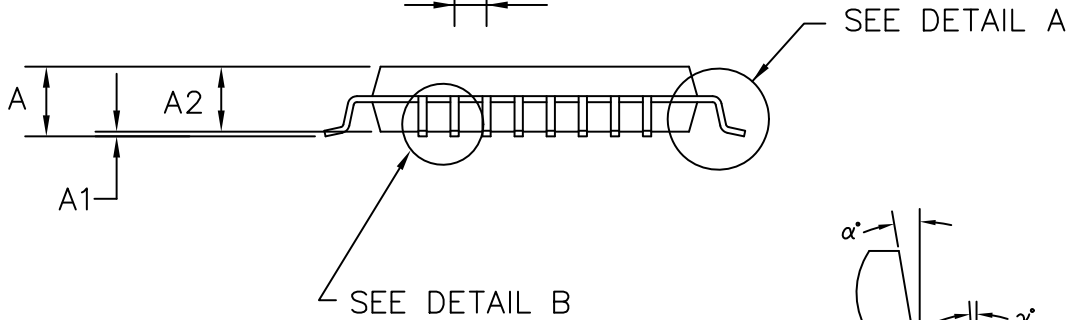

ALL DIMENSIONS IN MM

DOCUMENT NUMBER:	98AON30893E	Electronic versions are uncontrolled except when accessed directly from the Document Repository. Printed versions are uncontrolled except when stamped "CONTROLLED COPY" in red.
DESCRIPTION:	32 LEAD LQFP, 7X7	PAGE 1 OF 1

ON Semiconductor and are trademarks of Semiconductor Components Industries, LLC dba ON Semiconductor or its subsidiaries in the United States and/or other countries. ON Semiconductor reserves the right to make changes without further notice to any products herein. ON Semiconductor makes no warranty, representation or guarantee regarding the suitability of its products for any particular purpose, nor does ON Semiconductor assume any liability arising out of the application or use of any product or circuit, and specifically disclaims any and all liability, including without limitation special, consequential or incidental damages. ON Semiconductor does not convey any license under its patent rights nor the rights of others.

onsemi, **Onsemi**, and other names, marks, and brands are registered and/or common law trademarks of Semiconductor Components Industries, LLC dba "**onsemi**" or its affiliates and/or subsidiaries in the United States and/or other countries. **onsemi** owns the rights to a number of patents, trademarks, copyrights, trade secrets, and other intellectual property. A listing of **onsemi**'s product/patent coverage may be accessed at www.onsemi.com/site/pdf/Patent-Marking.pdf. **onsemi** reserves the right to make changes at any time to any products or information herein, without notice. The information herein is provided "as-is" and **onsemi** makes no warranty, representation or guarantee regarding the accuracy of the information, product features, availability, functionality, or suitability of its products for any particular purpose, nor does **onsemi** assume any liability arising out of the application or use of any product or circuit, and specifically disclaims any and all liability, including without limitation special, consequential or incidental damages. Buyer is responsible for its products and applications using **onsemi** products, including compliance with all laws, regulations and safety requirements or standards, regardless of any support or applications information provided by **onsemi**. "Typical" parameters which may be provided in **onsemi** data sheets and/or specifications can and do vary in different applications and actual performance may vary over time. All operating parameters, including "Typicals" must be validated for each customer application by customer's technical experts. **onsemi** does not convey any license under any of its intellectual property rights nor the rights of others. **onsemi** products are not designed, intended, or authorized for use as a critical component in life support systems or any FDA Class 3 medical devices or medical devices with a same or similar classification in a foreign jurisdiction or any devices intended for implantation in the human body. Should Buyer purchase or use **onsemi** products for any such unintended or unauthorized application, Buyer shall indemnify and hold **onsemi** and its officers, employees, subsidiaries, affiliates, and distributors harmless against all claims, costs, damages, and expenses, and reasonable attorney fees arising out of, directly or indirectly, any claim of personal injury or death associated with such unintended or unauthorized use, even if such claim alleges that **onsemi** was negligent regarding the design or manufacture of the part. **onsemi** is an Equal Opportunity/Affirmative Action Employer. This literature is subject to all applicable copyright laws and is not for resale in any manner.

PUBLICATION ORDERING INFORMATION

LITERATURE FULFILLMENT:

Email Requests to: orderlit@onsemi.com

onsemi Website: www.onsemi.com

TECHNICAL SUPPORT

North American Technical Support:

Voice Mail: 1 800-282-9855 Toll Free USA/Canada

Phone: 011 421 33 790 2910

Europe, Middle East and Africa Technical Support:

Phone: 00421 33 790 2910

For additional information, please contact your local Sales Representative

Mouser Electronics

Authorized Distributor

Click to View Pricing, Inventory, Delivery & Lifecycle Information:

[onsemi:](#)

[MC100EP195BFAG](#) [MC100EP195BFAR2G](#) [MC100EP195BMNG](#) [MC100EP195BMNR4G](#)