

# LUXEON HL2X

Higher performance, color stability, lumen maintenance, and longevity.

LUXEON HL2X is a high-power domed emitter designed specifically for outdoor and industrial applications like streetlights and high bay luminaires. The package is designed to deliver superior output, efficacy, color stability and longevity regardless of application or environment.

LUXEON HL2X utilizes an industry standard 3535 package with 3-stripe footprint. This compatibility allows for efficient and simpler conversion to the better performing LUXEON HL2X from any other similar platform.

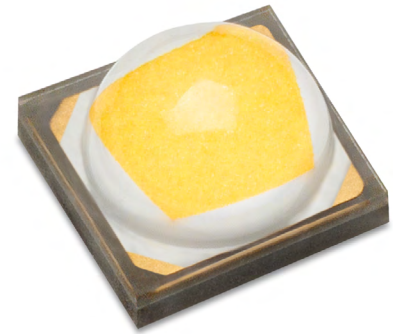

## FEATURES AND BENEFITS

Most usable light in application with a design emphasis on Beam Angle, Field Angle, Color Over Angle, and Optical Efficiency performance

CSP die technology enables high efficacy and high driving current capability in unique applications

Industry standard 3535 package with 3-stripe footprint and radiation pattern matched to LUXEON TX for ease of design

DLC R9 enabled to offer best-in-class color quality for luminaires

Offered in three different Luminous Flux Performance categories for customer flexibility in design and application

## PRIMARY APPLICATIONS

High Mast

Floodlights

Spotlights

High Bay

Low Bay

Torch

[More...](#)

# Table of Contents

<b>General Product Information</b> .....	<b>2</b>
Product Test Conditions .....	2
Part Number Nomenclature .....	2
Lumen Maintenance .....	2
Environmental Compliance .....	2
<b>Performance Characteristics</b> .....	<b>3</b>
Product Selection Guide .....	3
Optical Characteristics .....	4
Electrical and Thermal Characteristics .....	4
<b>Absolute Maximum Ratings</b> .....	<b>5</b>
Operating Conditions .....	5
<b>Characteristic Curves</b> .....	<b>6</b>
Spectral Power Distribution Characteristics .....	6
Light Output Characteristics .....	8
Forward Current Characteristics .....	9
Radiation Pattern Characteristics .....	10
<b>Product Bin and Labeling Definitions</b> .....	<b>12</b>
Decoding Product Bin Labeling .....	12
<b>Luminous Flux Bins</b> .....	<b>13</b>
Color Bin Definitions .....	14
Forward Voltage Bins .....	15
<b>Mechanical Dimensions</b> .....	<b>15</b>
<b>Reflow Soldering Guidelines</b> .....	<b>17</b>
JEDEC Moisture Sensitivity .....	17
Solder Pad Design .....	18
<b>Packaging Information</b> .....	<b>18</b>
Pocket Tape Dimensions .....	18
Reel Dimensions .....	20

# General Product Information

## Product Test Conditions

LUXEON HL2X LEDs are tested and binned with a DC drive current of 700mA, at a junction temperature,  $T_j$ , of 85°C.

## Part Number Nomenclature

Part numbers for LUXEON HL2X follow the convention below:

L 1 H X – **A A B B** 2 **C** z z z z z z z

Where:

- A A** – can be any alphanumeric character that designates nominal ANSI CCT (for example, 18=2800K, 27=2700K, 30=3000K, 35=3500K, 40=4000K, 50=5000K, 57=5700K, 65=6500K)
- B B** – can be any alphanumeric character that designates minimum CRI (for example, 70=70CRI, 80=80CRI, 90=90CRI)
- C** – can be alphanumeric character that designates performance options (for example, 0=Standard, P=High Flux Performance, D= High Flux Plus Performance)
- zzzzzz – can be any alphanumeric character that can be used to designate customer-specific options

Therefore, the following part number is used for a LUXEON HL2X 3000K 70CRI LED:

L 1 H X – **3 0 7 0** 2 **0** 0 0 0 0 0 0

## Lumen Maintenance

Please contact your local Sales Representative or Lumileds Technical Solutions Manager for more information about the long-term performance of this product.

## Environmental Compliance

Lumileds LLC is committed to providing environmentally friendly products to the solid-state lighting market. LUXEON HL2X is compliant to the European Union directives on the restriction of hazardous substances in electronic equipment, namely the RoHS Directive 2011/65/EU and REACH Regulation (EC) 1907/2006. Lumileds LLC will not intentionally add the following restricted materials to its products: lead, mercury, cadmium, hexavalent chromium, polybrominated biphenyls (PBB) or polybrominated diphenyl ethers (PBDE).

# Performance Characteristics

## Product Selection Guide

Table 1. Product performance of LUXEON HL2X at 700mA, T<sub>j</sub>=85°C.

NOMINAL CCT	MINIMUM R9 <sup>[3]</sup>	MINIMUM CRI <sup>[1]</sup>	LUMINOUS FLUX <sup>[2]</sup> (lm)		TYPICAL LUMINOUS EFFICACY (lm/W)	PART NUMBER
			MINIMUM	TYPICAL		
			700mA			
2700K	-40	70	290	311	159	L1HX-27702D0000000
3000K	-40	70	310	325	166	L1HX-30702D0000000
3500K	-40	70	310	330	168	L1HX-35702D0000000
4000K	-40	70	320	343	175	L1HX-40702D0000000
5000K	-40	70	310	337	172	L1HX-50702D0000000
5700K	-40	70	320	343	175	L1HX-57702D0000000
6500K	-40	70	310	343	175	L1HX-65702D0000000
3000K	-40	70	320	n/a		L1HX-30702D0000320
4000K	-40	70	340	n/a		L1HX-40702D0000340
5700K	-40	70	340	n/a		L1HX-57702D0000340
6500K	-40	70	340	n/a		L1HX-65702D0000340
2700K	-40	70	290	313	160	L1HX-27702P0000000
3000K	-40	70	300	318	162	L1HX-30702P0000000
3500K	-40	70	310	330	168	L1HX-35702P0000000
4000K	-40	70	320	338	173	L1HX-40702P0000000
5000K	-40	70	310	338	173	L1HX-50702P0000000
5700K	-40	70	310	338	173	L1HX-57702P0000000
6500K	-40	70	310	330	168	L1HX-65702P0000000
2700K	-40	70	290	310	156	L1HX-2770200000000
3000K	-40	70	300	318	161	L1HX-3070200000000
3500K	-40	70	300	325	164	L1HX-3570200000000
4000K	-40	70	300	333	168	L1HX-4070200000000
5000K	-40	70	300	333	168	L1HX-5070200000000
5700K	-40	70	300	333	168	L1HX-5770200000000
6500K	-40	70	300	333	168	L1HX-6570200000000
1800K	0	80	180	190	97	L1HX-18802D0000000
3000K	0	80	270	290	148	L1HX-30802D0000000
4000K	0	80	290	311	159	L1HX-40802D0000000
5000K	0	80	290	320	163	L1HX-50802D0000000
5700K	0	80	300	320	163	L1HX-57802D0000000
3000K	0	80	260	284	145	L1HX-30802P0000000
4000K	0	80	290	313	160	L1HX-40802P0000000
5000K	0	80	290	313	160	L1HX-50802P0000000
5700K	0	80	290	313	160	L1HX-57802P0000000
2700K	0	80	250	270	136	L1HX-2780200000000
3000K	0	80	260	280	141	L1HX-3080200000000
3500K	0	80	270	290	146	L1HX-3580200000000
4000K	0	80	280	307	155	L1HX-4080200000000
5000K	0	80	280	310	156	L1HX-5080200000000
5700K	0	80	280	310	156	L1HX-5780200000000

Table 1 continued on next page:

1. Lumileds maintains a tolerance of ±2 on CRI.
2. Lumileds maintains a tester tolerance of ±6.5% on luminous flux measurements.
3. Lumileds maintains a tester tolerance of ±6.5 on R9 measurements.

Table 1. Product performance of LUXEON HL2X at 700mA, T<sub>j</sub>=85°C, Continued.

NOMINAL CCT	MINIMUM R9 <sup>[3]</sup>	MINIMUM CRI <sup>[1]</sup>	LUMINOUS FLUX <sup>[2]</sup> (lm)		TYPICAL LUMINOUS EFFICACY (lm/W)	PART NUMBER
			MINIMUM	TYPICAL		
			700mA			
3000K	50	90	220	242	123	L1HX-30902D0000000
4000K	50	90	240	256	131	L1HX-40902D0000000
5700K	50	90	250	272	139	L1HX-57902D0000000
3000K	50	90	210	235	120	L1HX-30902P0000000
4000K	50	90	240	261	133	L1HX-40902P0000000
5700K	50	90	245	267	136	L1HX-57902P0000000
2700K	50	90	195	213	108	L1HX-2790200000000
3000K	50	90	210	233	118	L1HX-3090200000000
3500K	50	90	220	235	119	L1HX-3590200000000
4000K	50	90	240	257	130	L1HX-4090200000000
5000K	50	90	240	257	130	L1HX-5090200000000
5700K	50	90	240	260	131	L1HX-5790200000000

Notes for Table 1:

1. Lumileds maintains a tolerance of ±2 on CRI.
2. Lumileds maintains a tester tolerance of ±6.5% on luminous flux measurements.
3. Lumileds maintains a tester tolerance of ±6.5 on R9 measurements.

## Optical Characteristics

Table 2. Optical characteristics for LUXEON HL2X at 700mA, T<sub>j</sub>=85°C.

PART NUMBER	TYPICAL TOTAL INCLUDED ANGLE <sup>[1]</sup>	TYPICAL VIEWING ANGLE <sup>[2]</sup>
L1HX-xxxx2x0000000	160°	120°

Notes for Table 2:

1. Total angle at which 90% of total luminous flux is captured.
2. Viewing angle is the off axis angle from the LED centerline where the luminous intensity is ½ of the peak value.

## Electrical and Thermal Characteristics

Table 3. Electrical and thermal characteristics for LUXEON HL2X at 700mA, T<sub>j</sub>=85°C.

PART NUMBER	FORWARD VOLTAGE <sup>[1]</sup> (V <sub>f</sub> )			TYPICAL TEMPERATURE COEFFICIENT OF FORWARD VOLTAGE <sup>[2]</sup> (mV/°C)	TYPICAL THERMAL RESISTANCE—JUNCTION TO SOLDER PAD (°C/W)
	MINIMUM	TYPICAL	MAXIMUM		
L1HX-xxxx200000000		2.83			2.4
L1HX-xxxx2P0000000/L1HX-xxxx2D0000000	2.65	2.80	3.00	-1.6	2.4

Notes for Table 3:

1. Lumileds maintains a tolerance of ±0.1V on forward voltage measurements.
2. Measured between 25°C and 110°C.

# Absolute Maximum Ratings

Table 4. Absolute maximum ratings for LUXEON HL2X.

PARAMETER	MAXIMUM PERFORMANCE	
DC Forward Current <sup>[1, 2, 5]</sup>	2000mA	2500mA
Peak Pulsed Forward Current <sup>[1, 3]</sup>	2500mA	2500mA
LED Junction Temperature <sup>[1]</sup> (DC & Pulse)	135°C	125°C
ESD Sensitivity (ANSI/ESDA/JEDEC JS-001-2012)	Class 3B	
Operating Case Temperature <sup>[1]</sup>	-40°C to 135°C	
LED Storage Temperature	-40°C to 135°C	
Soldering Temperature	JEDEC 020c 260°C	
Allowable Reflow Cycles	3	
Reverse Voltage <sup>[4]</sup> ( $V_{reverse}$ )	LUXEON LEDs are not designed to be driven in reverse bias	

**Notes for Table 4:**

1. Proper current derating must be observed to maintain the junction temperature below the maximum allowable junction temperature.
2. Residual periodic variations due to power conversion from alternating current (AC) to direct current (DC), also called "ripple," with frequencies  $\geq 100\text{Hz}$  and amplitude  $\leq 15\%$  of the maximum allowable DC forward current are acceptable, assuming the average current throughout each cycle does not exceed the maximum allowable DC forward current at the corresponding maximum junction temperature.
3. Pulsed operation with a peak drive current equal to the stated peak pulsed forward current is acceptable if the pulse on-time is  $\leq 5\text{ms}$  per cycle and the duty cycle is  $\leq 50\%$ .
4. Transient reverse voltages and surge currents due to electrical switching or supply interruptions are acceptable if these events do not last for more than 10ms, the amplitude of the reverse voltage does not exceed 5V and the reverse current is less than 220uA.
5. For torch application with portable battery source, maximum surge transient current during the initial turn-on is 3.5A for 180ms and thereafter not to exceed DC maximum rating current and LED junction temperature.

## Operating Conditions

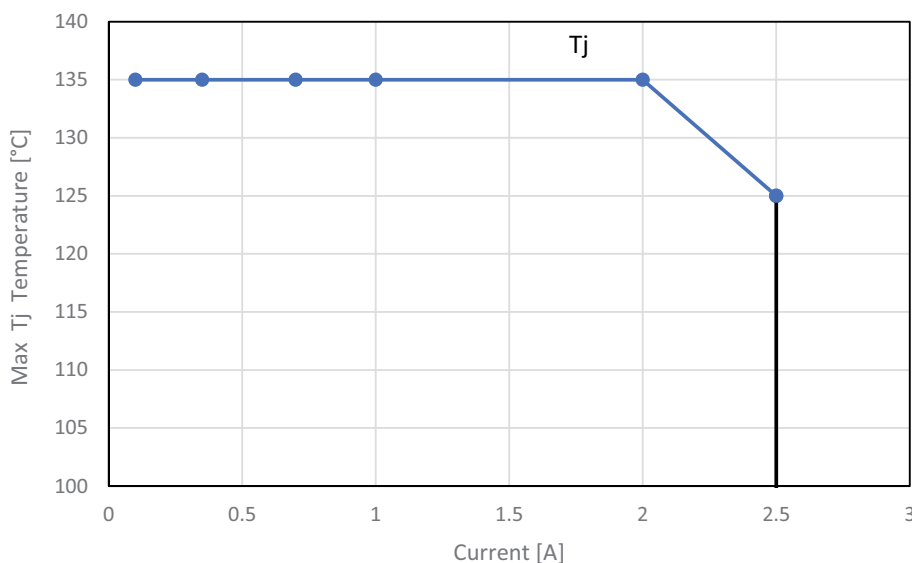

Figure 1. Maximum permissible operating conditions for LUXEON HL2X.

# Characteristic Curves

## Spectral Power Distribution Characteristics

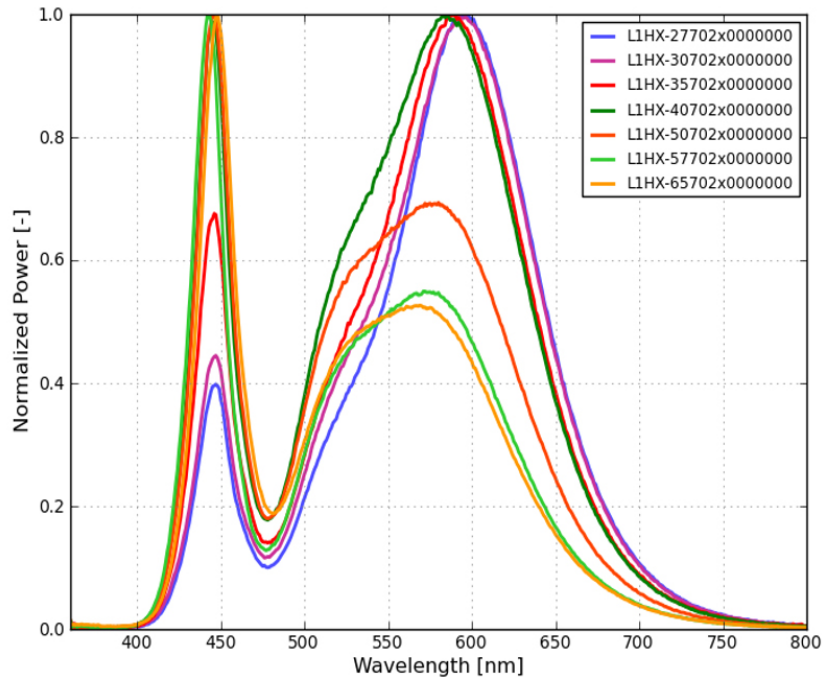

Figure 2a. Typical normalized power vs. wavelength for LUXEON HL2X 70 CRI at 700mA,  $T_j=85^{\circ}\text{C}$ .

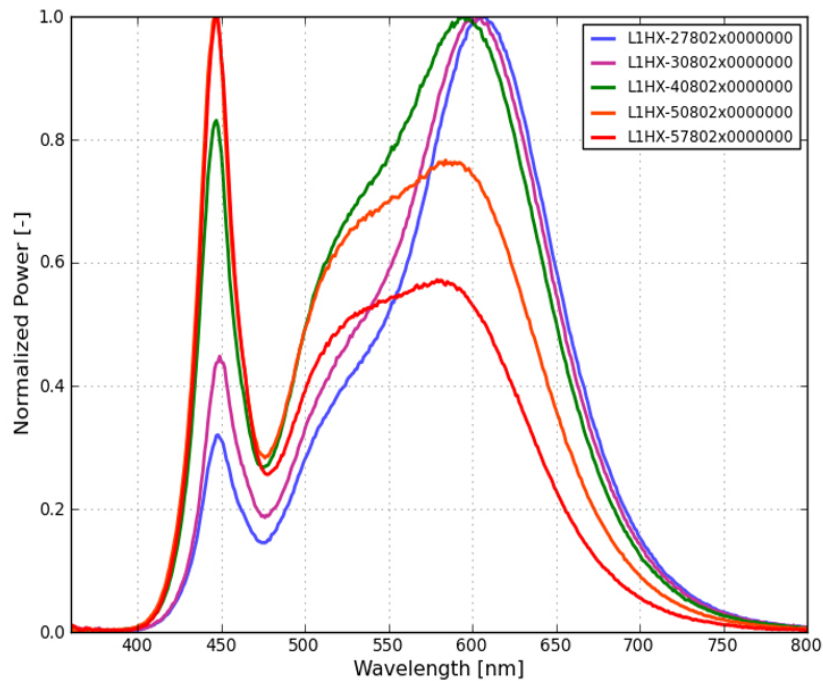

Figure 2b. Typical normalized power vs. wavelength for LUXEON HL2X 80 CRI at 700mA,  $T_j=85^{\circ}\text{C}$ .

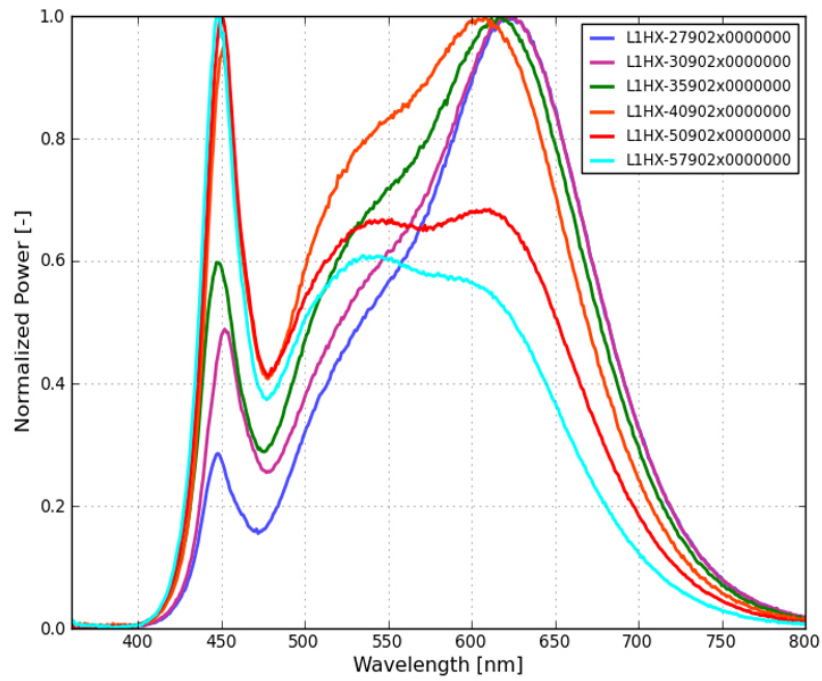

Figure 2c. Typical normalized power vs. wavelength for LUXEON HL2X 90 CRI at 700mA,  $T_j=85^\circ\text{C}$ .

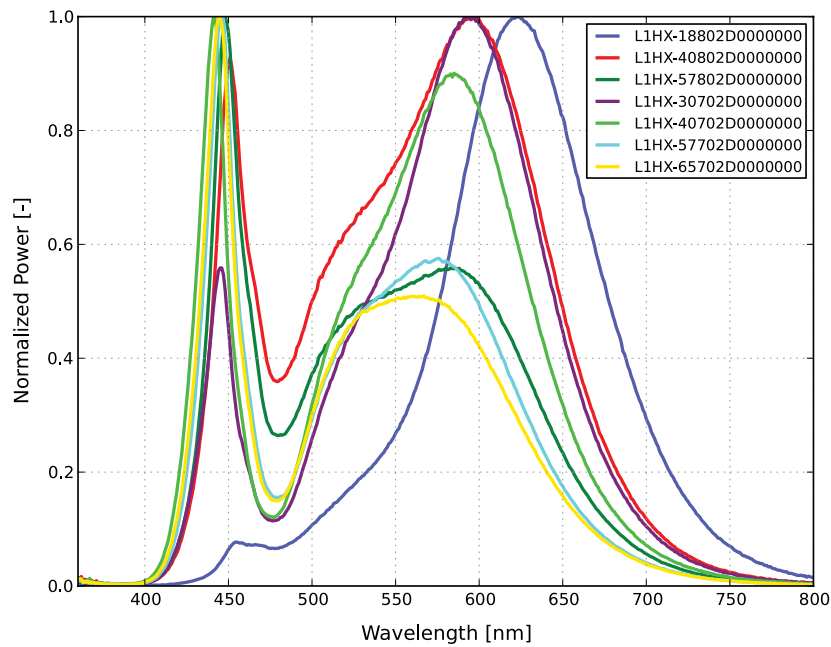

Figure 2d. Typical normalized power vs. wavelength for selected LUXEON HL2X-D 70 & 80 CRI at 700mA,  $T_j=85^\circ\text{C}$ .



# Light Output Characteristics

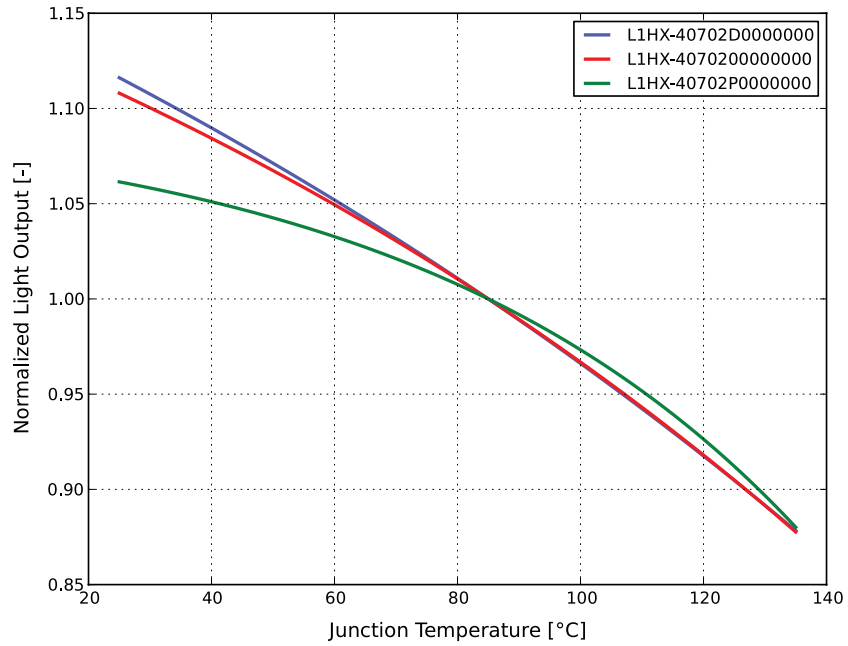

Figure 3a. Typical normalized light output vs. junction temperature for LUXEON HL2X (4000K 70CRI) at 700mA.

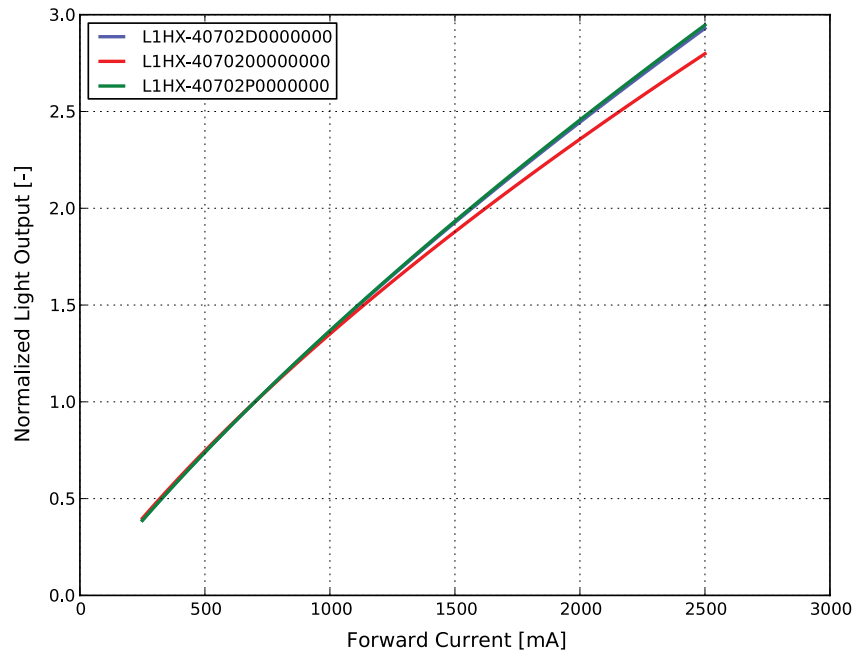

Figure 3b. Typical normalized light output vs. forward current for LUXEON HL2X (4000K 70CRI) at 700mA,  $T_j=85^\circ\text{C}$ .

# Forward Current Characteristics

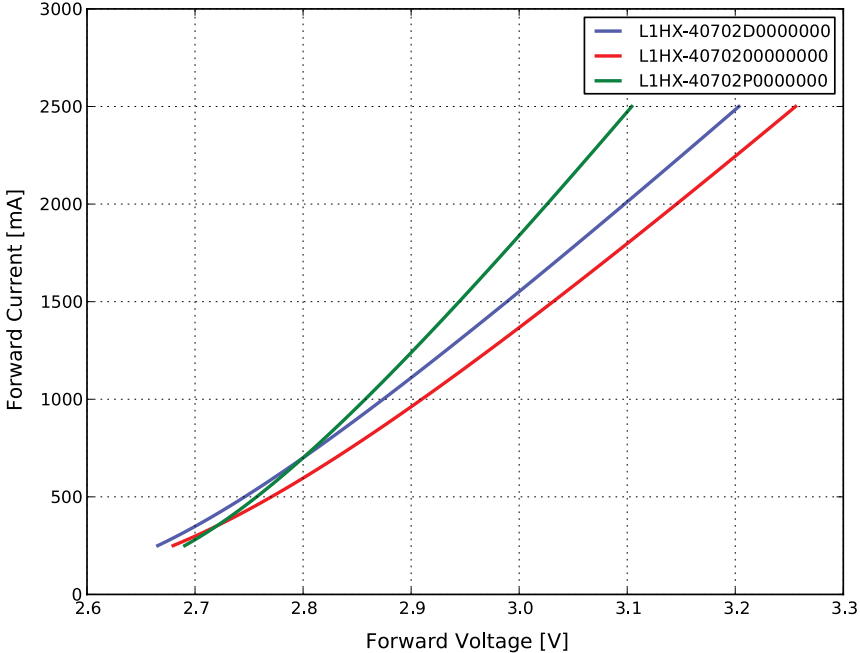

Figure 4. Typical forward current vs. forward voltage for LUXEON HL2X (4000K 70 CRI) at  $T_j=85^{\circ}\text{C}$ .

# Radiation Pattern Characteristics

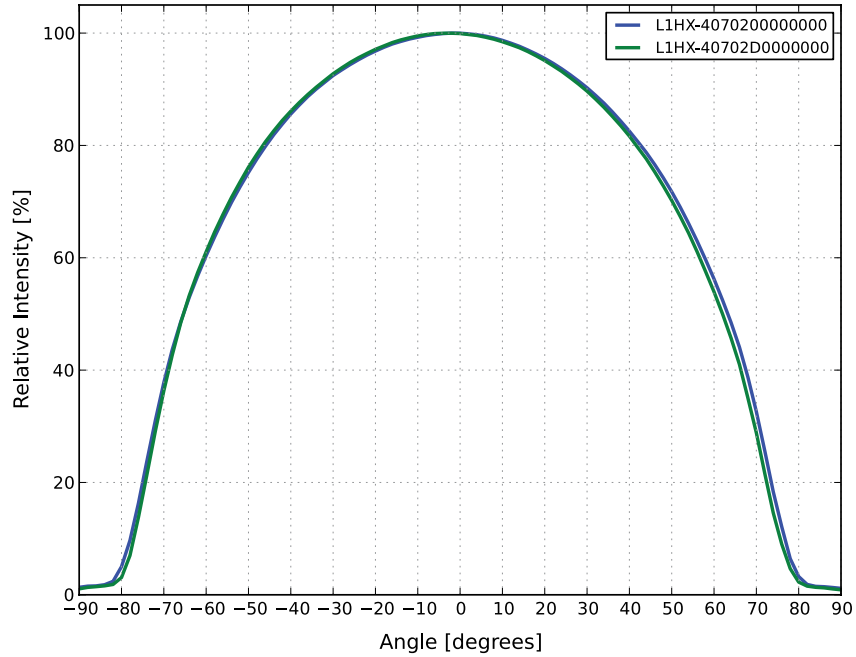

Figure 5a. Typical radiation pattern for LUXEON HL2X/HL2X-D at 700mA,  $T_j=85^\circ\text{C}$ .

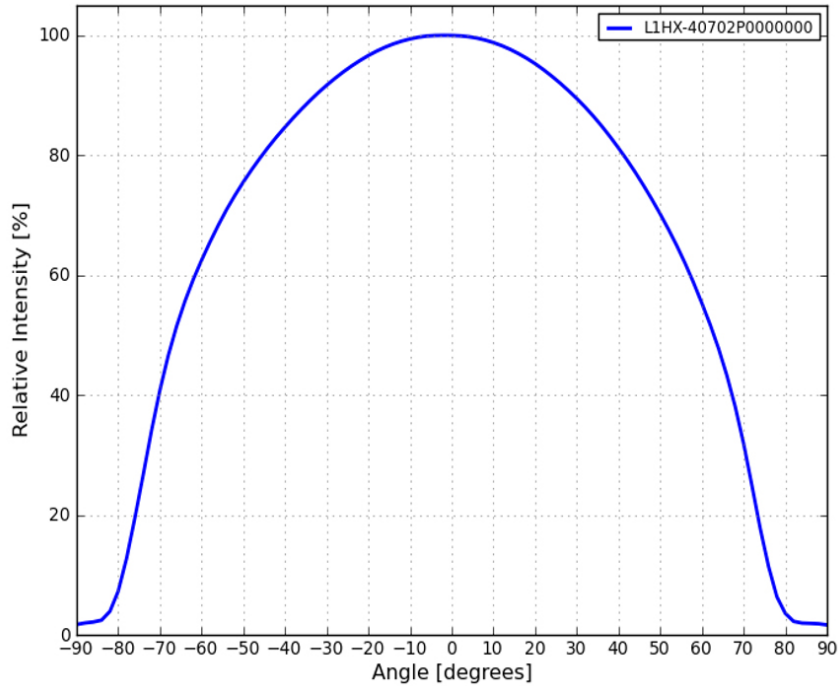

Figure 5b. Typical radiation pattern for LUXEON HL2X High Performance at 700mA,  $T_j=85^\circ\text{C}$ .

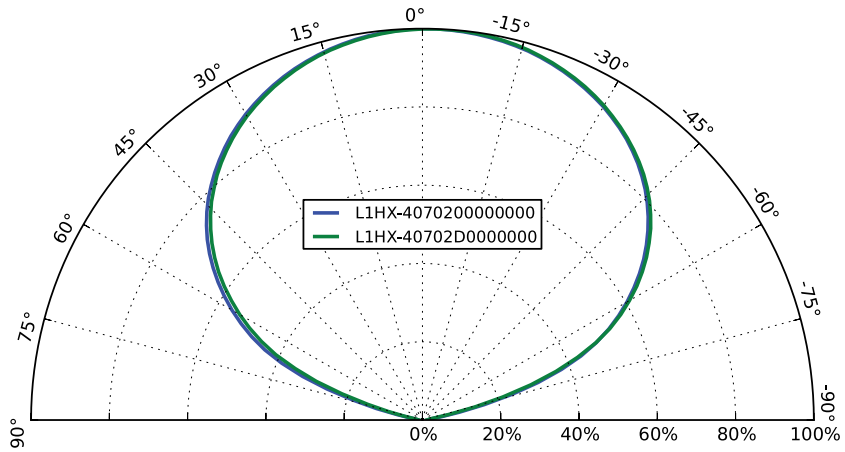

Figure 6a. Typical polar radiation pattern for LUXEON HL2X/HL2X-D at 700mA,  $T_j=85^\circ\text{C}$ .

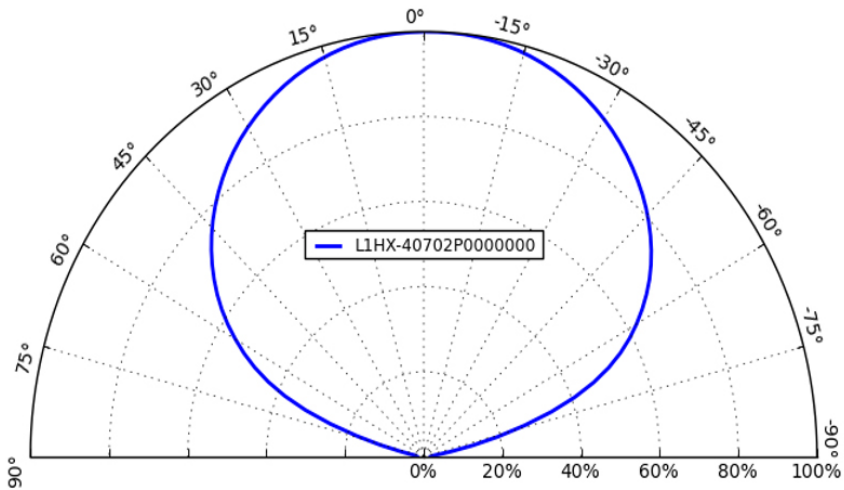

Figure 6b. Typical polar radiation pattern for LUXEON HL2X High Performance at 700mA,  $T_j=85^\circ\text{C}$ .

# Product Bin and Labeling Definitions

## Decoding Product Bin Labeling

In the manufacturing of semiconductor products, there are variations in performance around the average values given in the technical datasheet. For this reason, Lumileds bins LED components for luminous flux or radiometric power, color point, peak or dominant wavelength and forward voltage.

LUXEON HL2X LEDs are labeled using a 4-digit alphanumeric CAT code following the format below:

### **A B C D**

Where:

- A** – designates luminous flux bin (example: V=290 to 300 lm, W=300 to 310 lm)
- B** – designates color bin (example: 1=6500K, 2=5700K, 3=5000K, 5=4000K, 6=3500K, 7=3000K, 8=2700K, 9=2200K, B=1800K)
- C** – designates color space (example: 5/A/B/C/D=5-step MacAdam ellipse, 3/U/L=3-step MacAdam ellipse)
- D** – designates forward voltage bin (example: X=2.65 to 2.85V, Y=2.85 to 3.00V)

Therefore, a LUXEON HL2X 3000K 70CRI with a lumen range of 290 to 300 lm, color bin of 75 and a forward voltage range of 2.65 to 2.85V has the following CAT code:

### **V 7 5 X**

## Luminous Flux Bins

Table 5 lists the standard luminous flux bins for LUXEON HL2X emitters. Although several bins are outlined, product availability in a particular bin varies by production run and by product performance. Not all bins are available in all CCTs.

**Table 5. Luminous flux bin definitions for LUXEON HL2X.**

BIN	LUMINOUS FLUX <sup>(1)</sup> (lm)	
	MINIMUM	MAXIMUM
H	170	180
J	180	190
K	190	200
L	200	210
M	210	220
N	220	230
P	230	230
Q	240	250
R	250	260
S	260	270
T	270	280
U	280	290
V	290	300
W	300	310
X	310	320
Y	320	330
Z	330	340
A	340	350
B	350	360
C	360	370

**Notes for Table 5:**

1. Lumileds maintains a tolerance of  $\pm 6.5\%$  on luminous flux measurements.

# Color Bin Definitions

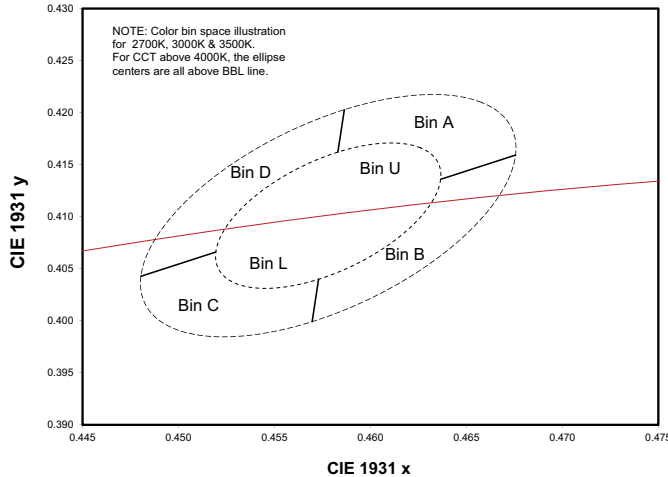

Figure 7. Color space definition for LUXEON HL2X.

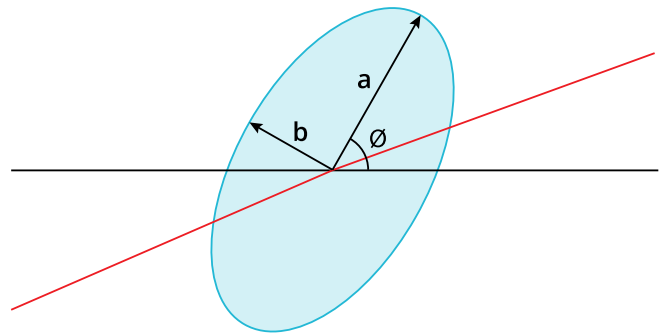

Figure 8. 5-step MacAdam ellipse illustration for Table 6.

Table 6. 5-step MacAdam ellipse color bin definitions for LUXEON HL2X.

NOMINAL CCT	COLOR SPACE	CENTER POINT <sup>[1]</sup> (cx, cy)	MAJOR AXIS, a	MINOR AXIS, b	ELLIPSE ROTATION ANGLE, θ
1800K	Single 5-step MacAdam ellipse	(0.5493, 0.4083)	0.016034	0.007705	47.34°
2700K	Single 5-step MacAdam ellipse	(0.4578, 0.4101)	0.013500	0.007000	53.70°
3000K	Single 5-step MacAdam ellipse	(0.4338, 0.4030)	0.013900	0.006800	53.22°
3500K	Single 5-step MacAdam ellipse	(0.4073, 0.3917)	0.015450	0.006900	54.0°
4000K	Single 5-step MacAdam ellipse	(0.3818, 0.3797)	0.015650	0.006700	53.72°
5000K	Single 5-step MacAdam ellipse	(0.3447, 0.3553)	0.013700	0.005900	59.62°
5700K	Single 5-step MacAdam ellipse	(0.3287, 0.3417)	0.012425	0.005325	59.09°
6500K	Single 5-step MacAdam ellipse	(0.3123, 0.3282)	0.011150	0.004750	58.57°

**Notes for Table 6:**

1. Lumileds maintains a tolerance of ±0.005 on x and y coordinates in the CIE 1931 color space.

Table 7. Correlated color temperature bin definitions for LUXEON HL2X.

BIN	CCT
1	6500K
2	5700K
3	5000K
5	4000K
6	3500K
7	3000K
8	2700K
B	1800K

Table 8. MacAdam ellipse color space definitions for LUXEON HL2X.

BIN	SDCM
3	3-step MacAdam ellipse (70 CRI)
U	3-step MacAdam ellipse (80,90 CRI)
L	3-step MacAdam ellipse (80,90 CRI)
5	5-step MacAdam ellipse (70 CRI)
A	5-step MacAdam ellipse (80,90 CRI)
B	5-step MacAdam ellipse (80,90 CRI)
C	5-step MacAdam ellipse (80,90 CRI)
D	5-step MacAdam ellipse (80,90 CRI)

# Forward Voltage Bins

Table 9. Forward voltage bin definitions for LUXEON HL2X.

BIN	FORWARD VOLTAGE <sup>(1)</sup> (V <sub>f</sub> )	
	MINIMUM	MAXIMUM
X	2.65	2.85
Y	2.85	3.00

Notes for Table 9:

1. Lumileds maintains a tolerance of ±0.1V on forward voltage measurements.

## Mechanical Dimensions

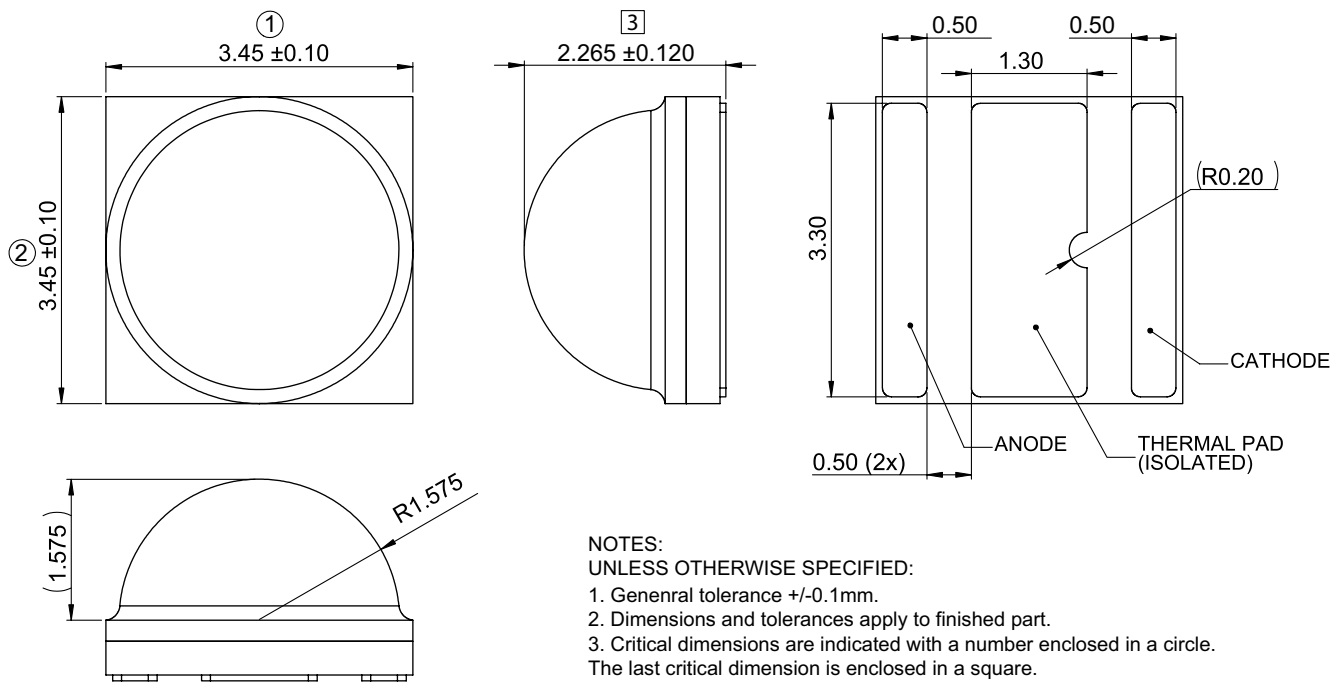

Figure 9a. Mechanical dimensions for LUXEON HL2X and LUXEON HL2X-P.

Notes for Figure 9a:

1. Drawings are not to scale.
2. All dimensions are in millimeters.
3. Do not handle the device by the dome. Excessive force on the dome may damage the dome itself or the interior of the device.



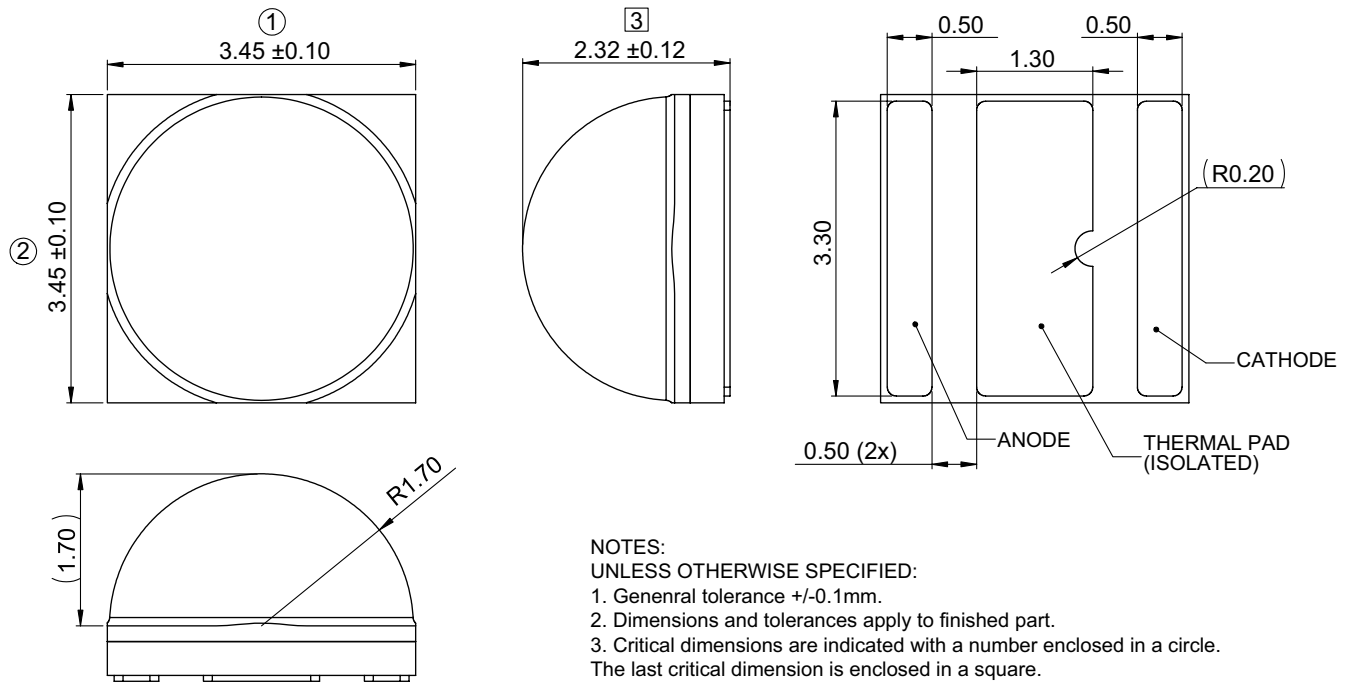

Figure 9b. Mechanical dimensions for LUXEON HL2X-D.

Notes for Figure 9b:

1. Drawings are not to scale.
2. All dimensions are in millimeters.
3. Do not handle the device by the dome. Excessive force on the dome may damage the dome itself or the interior of the device.

# Reflow Soldering Guidelines

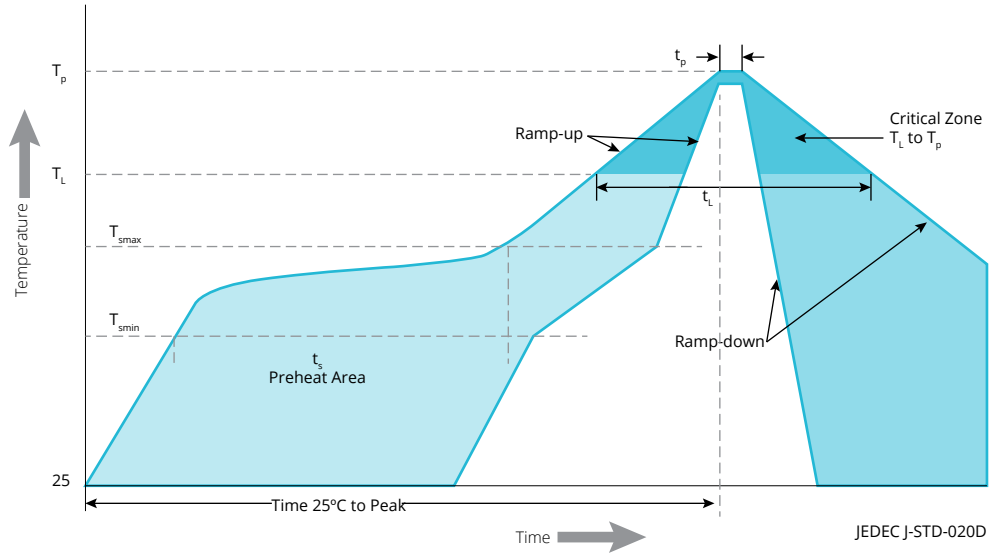

Figure 10. Visualization of the acceptable reflow temperature profile as specified in Table 10.

Table 10. Reflow profile characteristics for LUXEON HL2X.

PROFILE FEATURE	LEAD-FREE ASSEMBLY
Preheat Minimum Temperature ( $T_{smin}$ )	150°C
Preheat Maximum Temperature ( $T_{smax}$ )	200°C
Preheat Time ( $t_{smin}$ to $t_{smax}$ )	60 to 180 seconds
Ramp-Up Rate ( $T_L$ to $T_p$ )	3°C / second maximum
Liquidous Temperature ( $T_L$ )	217°C
Time Maintained Above Temperature $T_L$ ( $t_t$ )	60 to 150 seconds
Peak / Classification Temperature ( $T_p$ )	260°C
Time Within 5°C of Actual Peak Temperature ( $t_p$ )	20 to 40 seconds
Ramp-Down Rate ( $T_p$ to $T_L$ )	6°C / second maximum
Time 25°C to Peak Temperature	8 minutes maximum

**Notes for Table 10:**

1. All temperatures refer to the application Printed Circuit Board (PCB), measured on the surface adjacent to the package body.

## JEDEC Moisture Sensitivity

Table 11. Moisture sensitivity levels for LUXEON HL2X.

LEVEL	FLOOR LIFE		SOAK REQUIREMENTS STANDARD	
	TIME	CONDITIONS	TIME	CONDITIONS
1	Unlimited	≤30°C / 85% RH	168 Hours +5 / -0	85°C / 85% RH

# Solder Pad Design

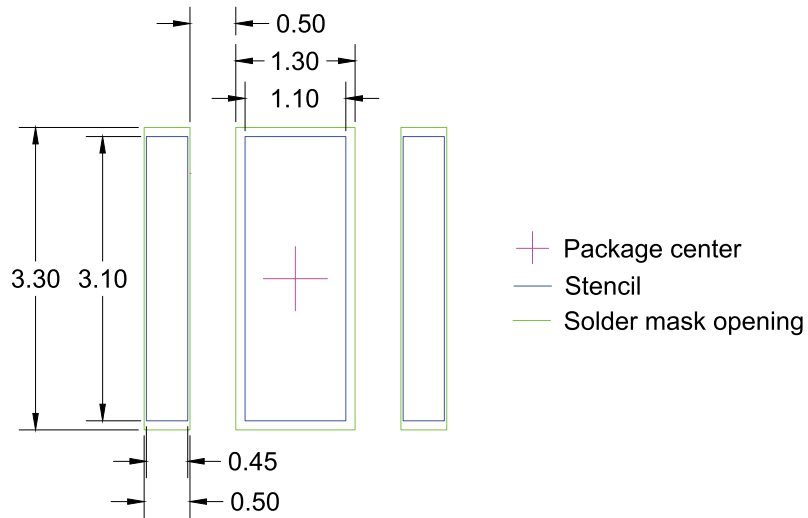

Figure 11. Recommended PCB solder pad layout for LUXEON HL2X.

**Notes for Figure 11:**

1. Drawings are not to scale.
2. All dimensions are in millimeters.

# Packaging Information

## Pocket Tape Dimensions

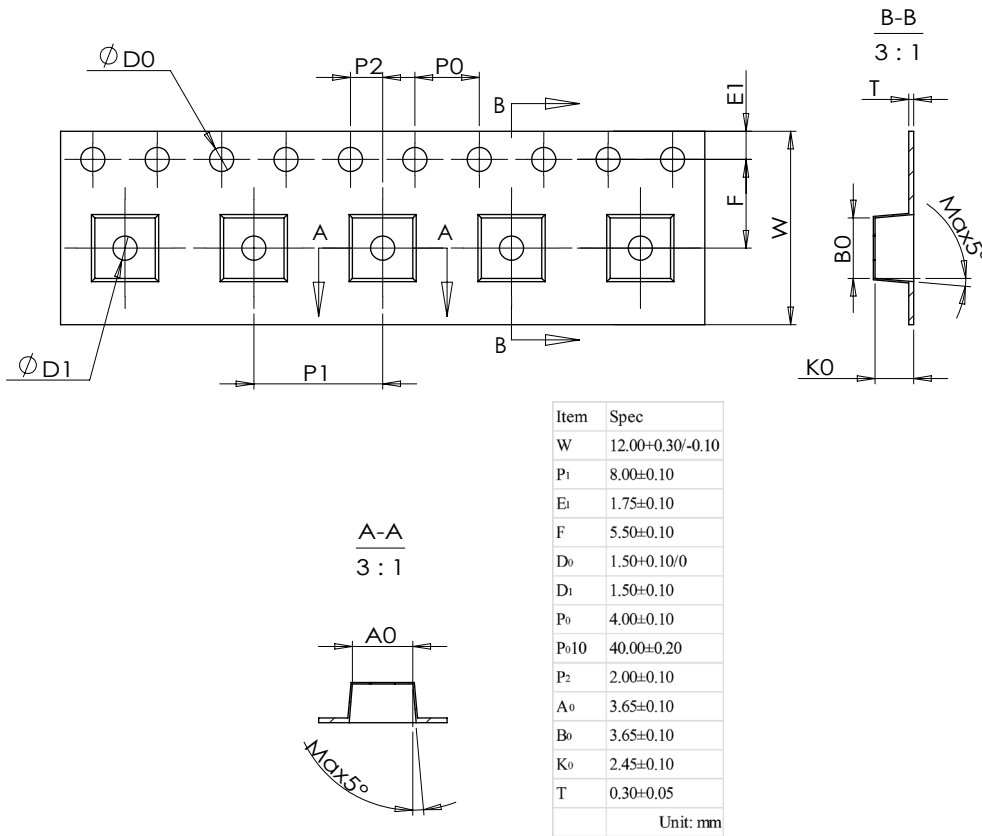
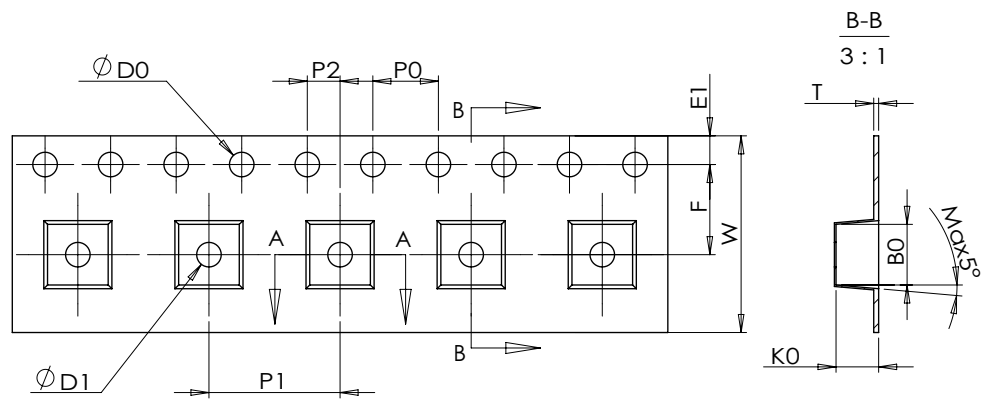

Figure 12a. Pocket tape dimensions for LUXEON HL2X and LUXEON HL2X-P.

**Notes for Figure 12a:**

1. Drawings are not to scale.
2. All dimensions are in millimeters.



A-A  
3 : 1

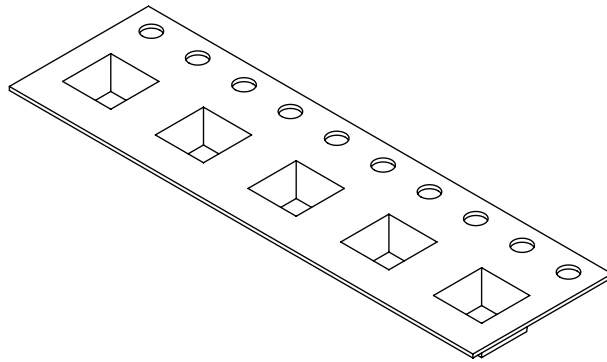
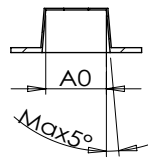

Item	Spec
W	12.00±0.30
P <sub>1</sub>	8.00±0.10
E <sub>1</sub>	1.75±0.10
F	5.50±0.10
D <sub>0</sub>	1.50+0.10/0
D <sub>1</sub>	1.50+0.10/0
P <sub>0</sub>	4.00±0.10
P <sub>010</sub>	40.00±0.20
P <sub>2</sub>	2.00±0.10
A <sub>0</sub>	3.72±0.10
B <sub>0</sub>	3.72±0.10
K <sub>0</sub>	2.60±0.10
T	0.30±0.05
Unit: mm	

Figure 12b. Pocket tape dimensions for LUXEON HL2X-D.

Notes for Figure 12b:

1. Drawings are not to scale.
2. All dimensions are in millimeters.

# Reel Dimensions

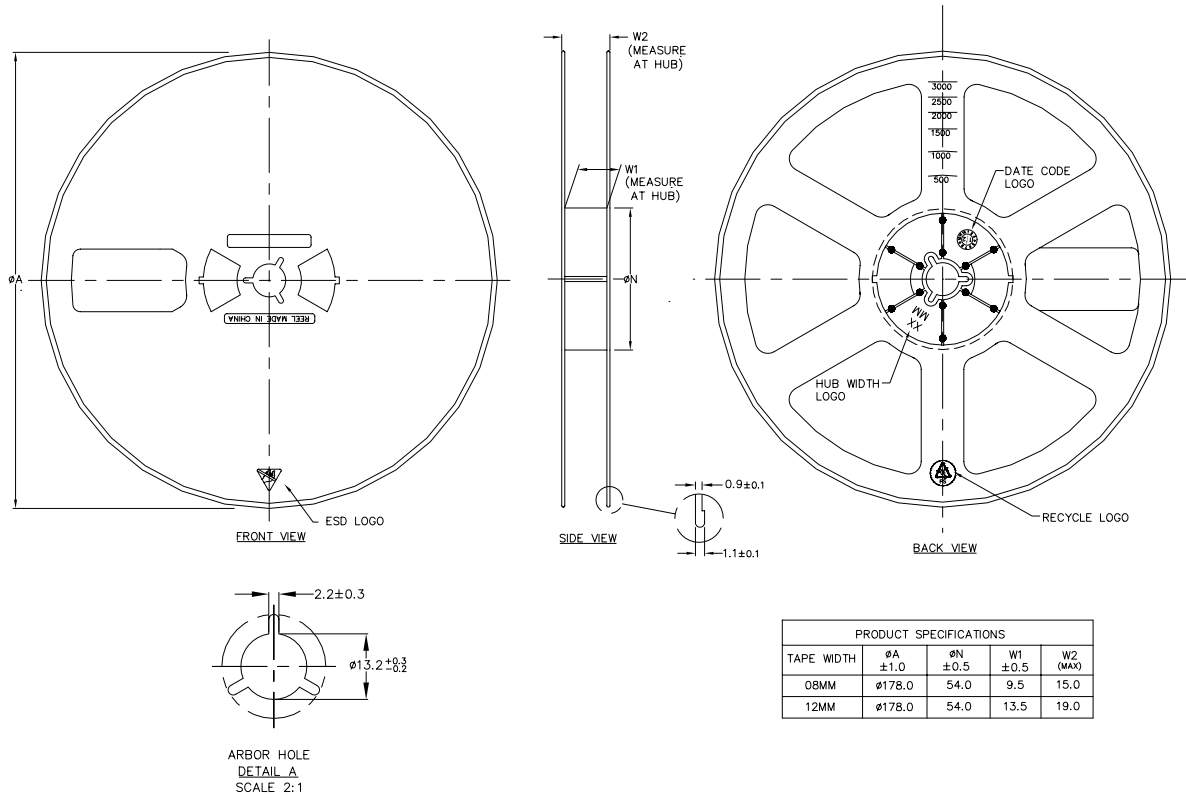

Figure 13. Reel dimensions for LUXEON HL2X/HL2X-P/HL2X-D.

**Notes for Figure 13:**

1. Drawings are not to scale.
2. All dimensions are in millimeters.
3. 1,000 pieces per reel for LUXEON HL2X/HL2X-P; 800 pieces per reel for LUXEON HL2X-D.

## About Lumileds

Companies developing automotive, mobile, IoT and illumination lighting applications need a partner who can collaborate with them to push the boundaries of light. With over 100 years of inventions and industry firsts, Lumileds is a global lighting solutions company that helps customers around the world deliver differentiated solutions to gain and maintain a competitive edge. As the inventor of Xenon technology, a pioneer in halogen lighting and the leader in high performance LEDs, Lumileds builds innovation, quality and reliability into its technology, products and every customer engagement. Together with its customers, Lumileds is making the world better, safer, more beautiful—with light.

To learn more about our lighting solutions, visit [lumileds.com](http://lumileds.com).



©2023 Lumileds Holding B.V. All rights reserved.  
LUXEON is a registered trademark of the Lumileds Holding B.V. in the United States and other countries.

[lumileds.com](http://lumileds.com)

Neither Lumileds Holding B.V. nor its affiliates shall be liable for any kind of loss of data or any other damages, direct, indirect or consequential, resulting from the use of the provided information and data. Although Lumileds Holding B.V. and/or its affiliates have attempted to provide the most accurate information and data, the materials and services information and data are provided "as is," and neither Lumileds Holding B.V. nor its affiliates warrants or guarantees the contents and correctness of the provided information and data. Lumileds Holding B.V. and its affiliates reserve the right to make changes without notice. You as user agree to this disclaimer and user agreement with the download or use of the provided materials, information and data. A listing of Lumileds product/patent coverage may be accessed at [lumileds.com/patents](http://lumileds.com/patents).

DS288 LUXEON HL2X  
Product Datasheet 20230706