

B AJ-145

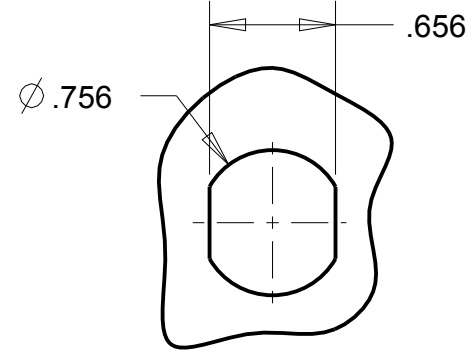

PANEL CUTOUT

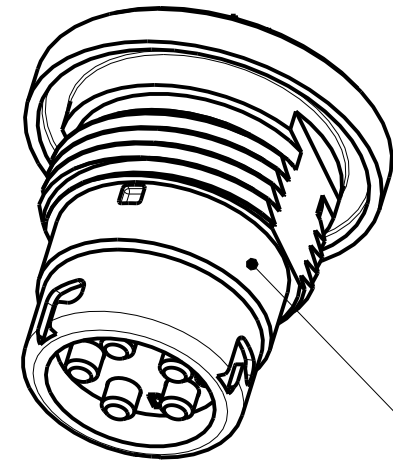

AJ-145-10  
5 CONDUCTOR  
PM PLUG SUB ASSY.

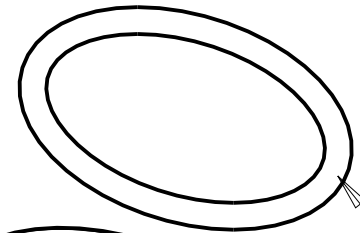

AP-136-36

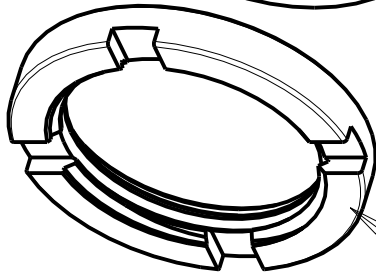

AJ-146-12

SCALE 2 :1

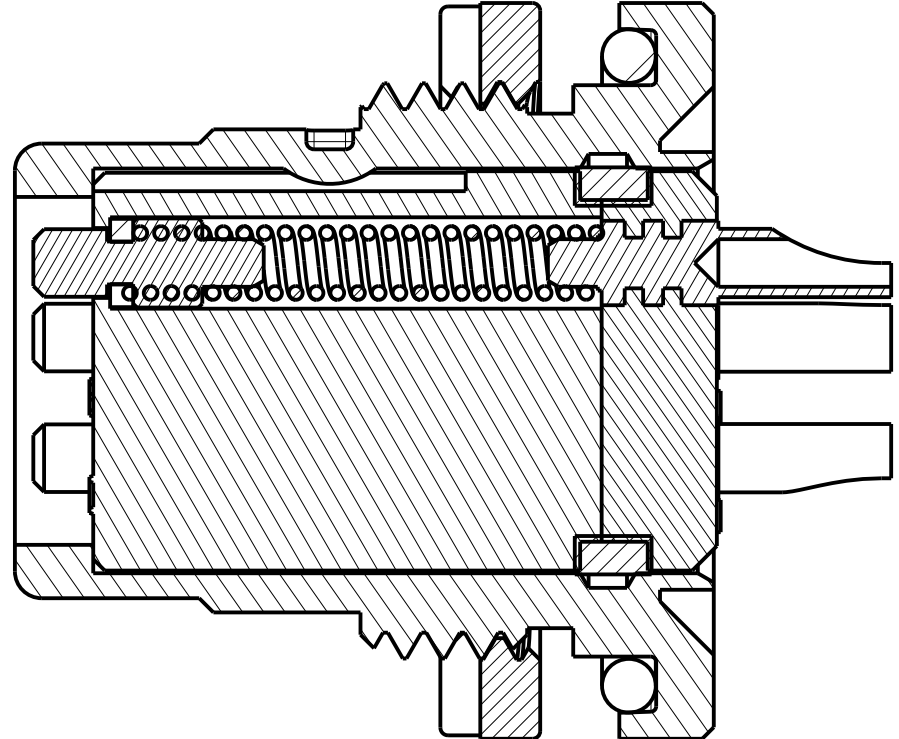
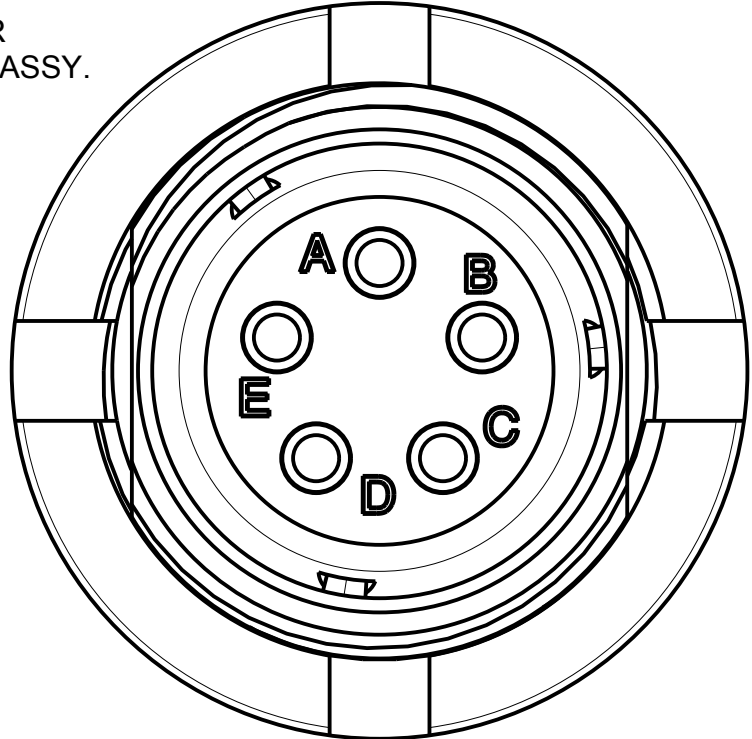

- NOTES:  
 1) CONNECTOR IS QUALIFIED TO MIL-DTL-55116  
 2) MILITARY PART IDENTIFYING NO:M55116/9-0  
 3) MARK MILITARY PART IDENTIFYING NO.,  
 MANUFACTURERS NAME AND CAGE CODE  
 LOCATED APPROXIMATELY AS SHOWN

THIS DOCUMENT CONTAINS PROPRIETARY INFORMATION OF NEXUS, INCORPORATED AND SUCH INFORMATION MAY NOT BE DISCLOSED TO OTHERS FOR ANY PURPOSE OR USED FOR ANY PURPOSE WITHOUT THE WRITTEN CONSENT OF NEXUS.

LET.	REVISION	CN #	DATE	CHK.
C	CHG AJ-146-13 TO AP-136-36	115	11/11 2011	HR
B	ADD NOTES 1 THRU 3	035	12/15 2009	GPH
A	RELEASED FOR PRODUCTION	032	11/23 2009	GPH

DWN.BY	LDE	DATE	05-Jun-09
CHECKED BY		DATE	
APPR.BY		DATE	

MATERIAL	
FINISH	
WEIGHT	SCALE = 4.00 :1
TITLE	
JACK -5 PIN SOLDER CUP, PM	
DO NOT SCALE DWG.	SHEET 1 OF 1

**NEXUS**  
STAMFORD, CONN

SIZE **B** DWG. NO. **AJ-145**

# Mouser Electronics

Authorized Distributor

Click to View Pricing, Inventory, Delivery & Lifecycle Information:

[Amphenol:](#)

[M55116/9](#) [M5511690](#) [M55116/9-0](#) [AJ-145/9](#) [AJ-145/9-0](#)