

THIS DRAWING IS UNPUBLISHED. RELEASED FOR PUBLICATION
 © COPYRIGHT copyright dbTe- ALL RIGHTS RESERVED.

REVISIONS					
P	LTR	DESCRIPTION	DATE	DWN	APVD
R		REDRAWN/REVISED PER ECO 17-001755	18MAY2017	RS	JO
RI		REVISED PER ECO-18-006412	04MAY2018	RS	JO

- 1 CONTACT AREA PLATED WITH 0.76µm MIN GOLD; SOLDER TAILS PLATED WITH 3.81µm MIN TIN-LEAD, ALL OVER 1.27µm MIN NICKEL.
- 2 POINT OF MEASUREMENT FOR PLATING THICKNESS.
- 3 CIRCUIT IDENTIFICATION FEATURE OMITTED ON 8,10,12 AND 14 POSN HEADER ASSEMBLIES.
- 4 DIMENSION APPLIES AT BASE OF SHROUD.
- 5 NOTE DELETED.
- 6 NOTE DELETED.
- 7 CONTACT AREA PLATED WITH 0.76µm MIN. GOLD; SOLDER TAILS PLATED WITH 3.81µm MIN TIN; ALL OVER 1.27µm MIN NICKEL.
- 8 FINISH: 0.025µm MIN GOLD ON GOLD PLATED AREA. 3.81-6.35µm MATTE TIN-LEAD ON TIN PLATED AREA. UNDER PLATING TO BE 1.27-2.54µm NICKEL ON ENTIRE CONTACT.
- 9 FINISH: 0.025µm MIN GOLD ON GOLD PLATED AREA. 3.81-6.35µm MATTE TIN ON TIN PLATED AREA. UNDER PLATING TO BE 1.27-2.54µm NICKEL ON ENTIRE CONTACT.
- 10 NOTE DELETED.
- 11 NOTE DELETED.
- 12 MATERIAL : HOUSING : LCP
 COLOR : BLACK
 POST : COPPER ALLOY.

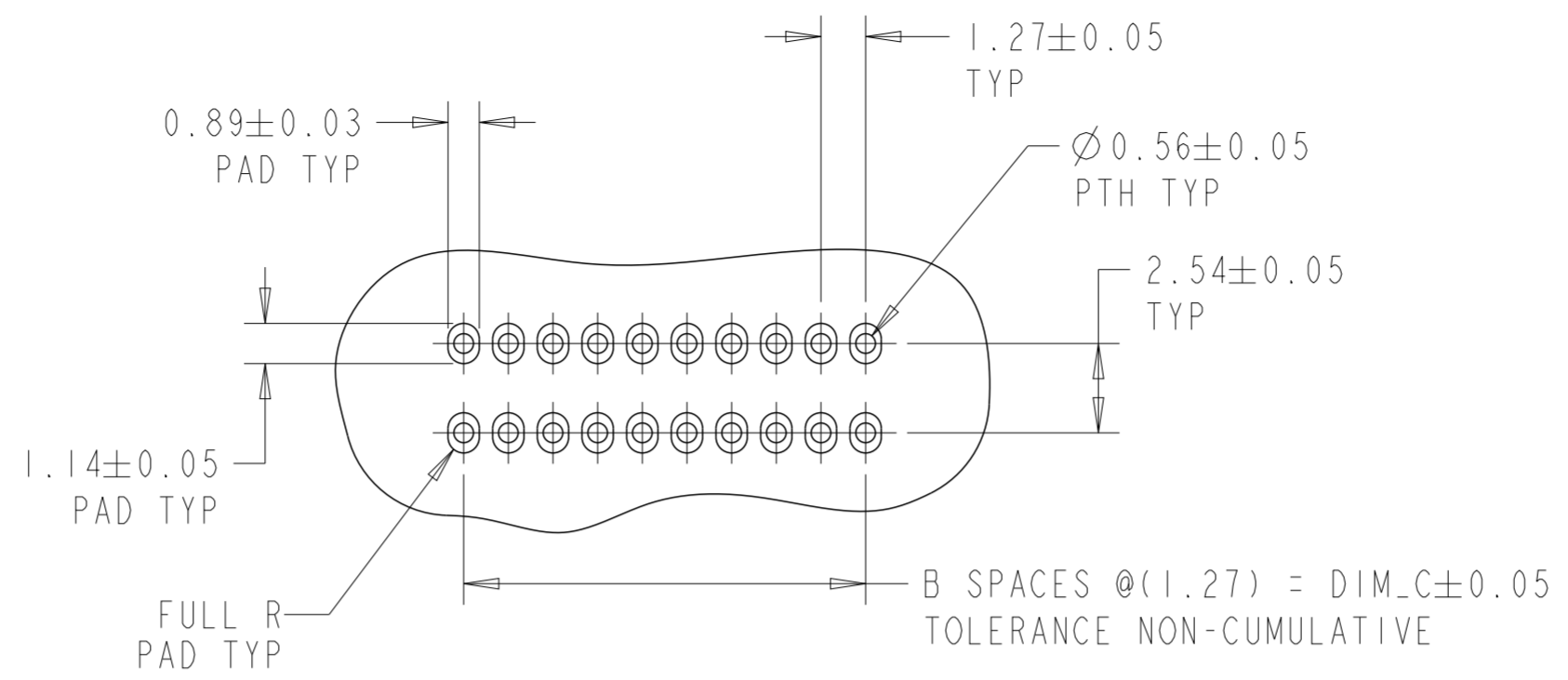

RECOMMENDED PC BOARD LAYOUT

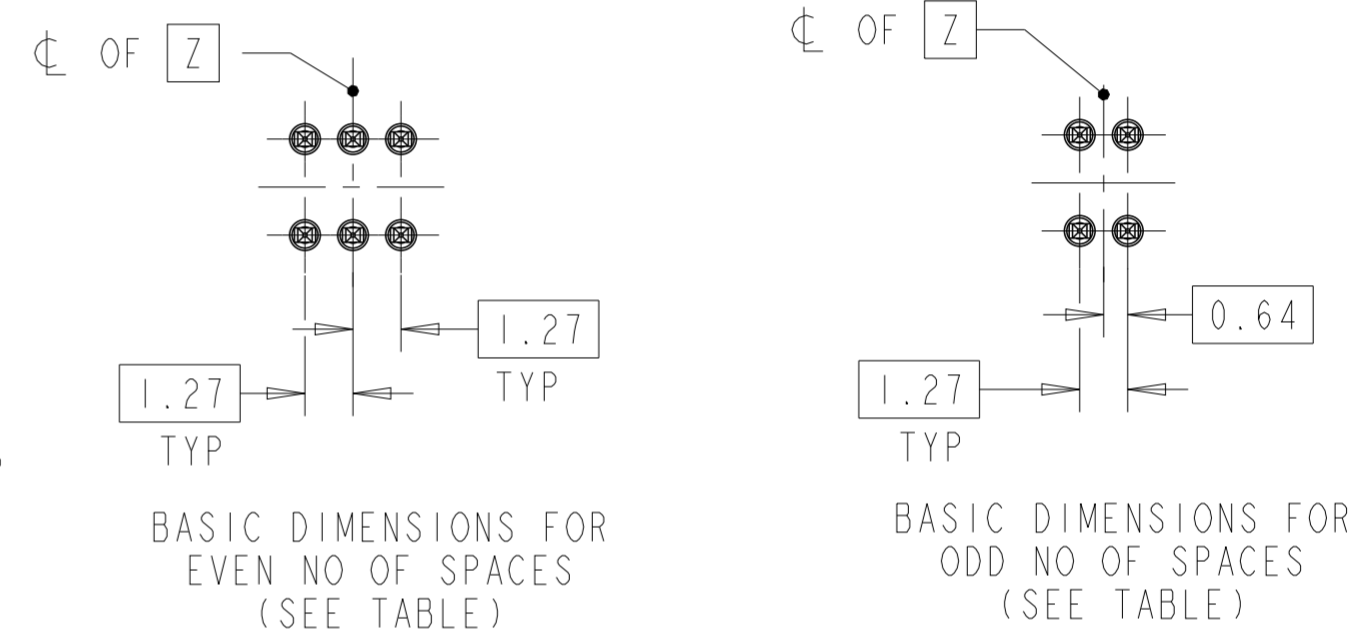

DETAIL R

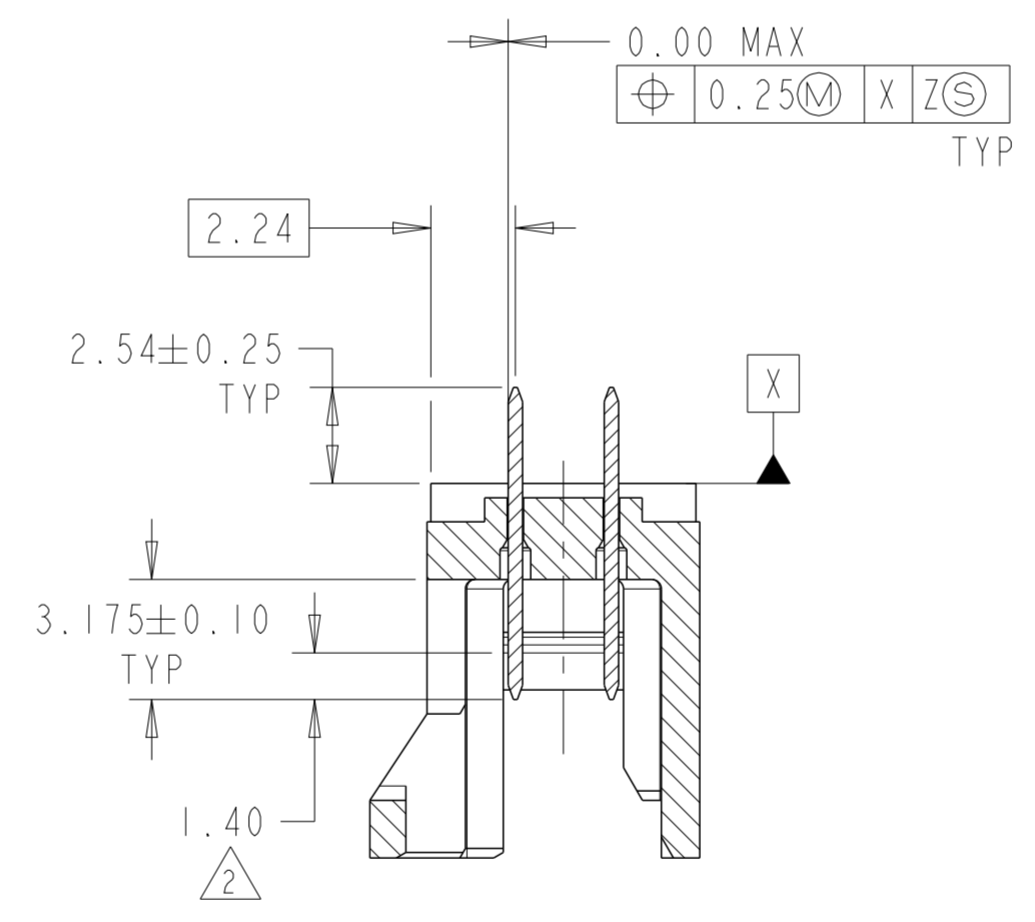

SECTION A-A

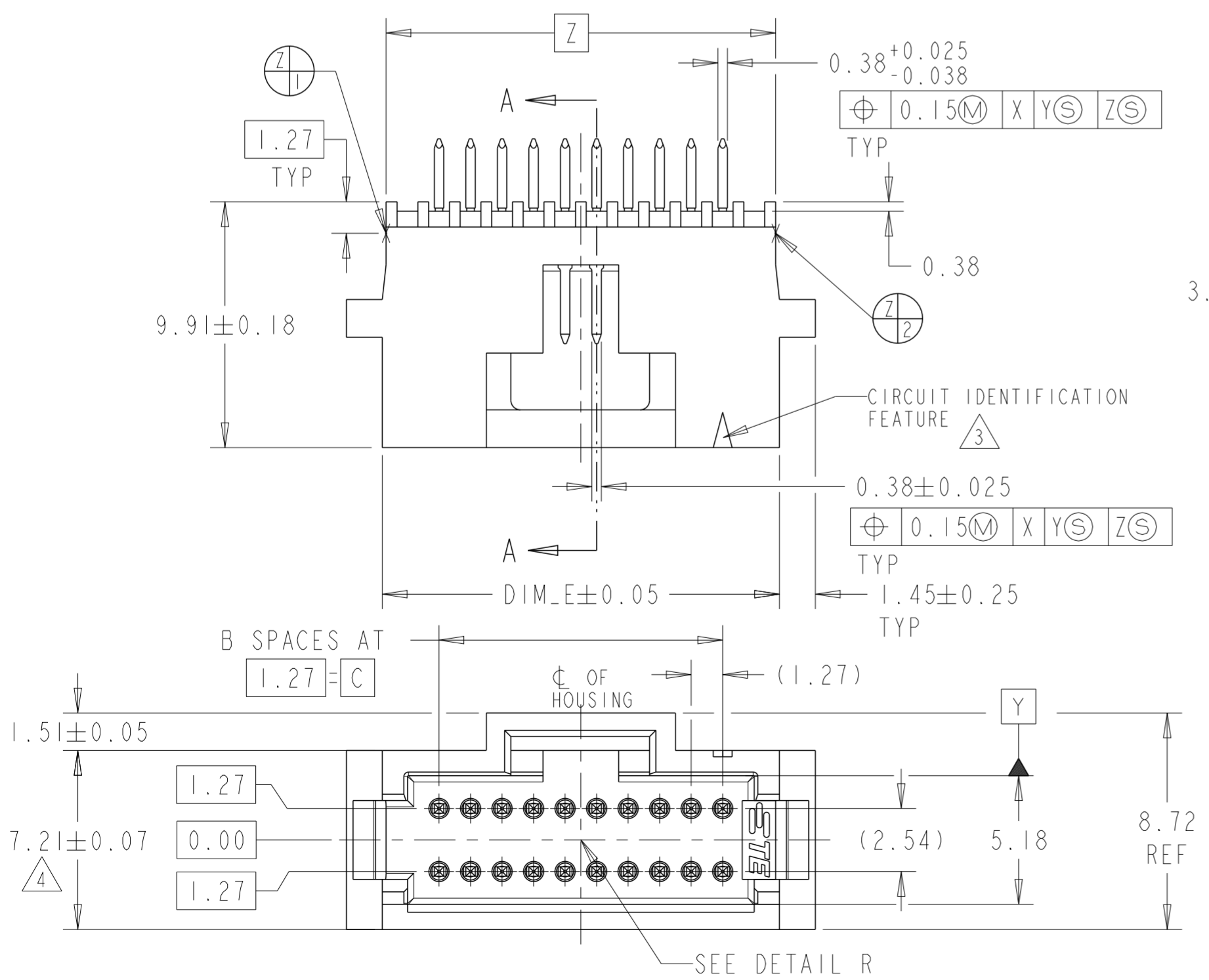
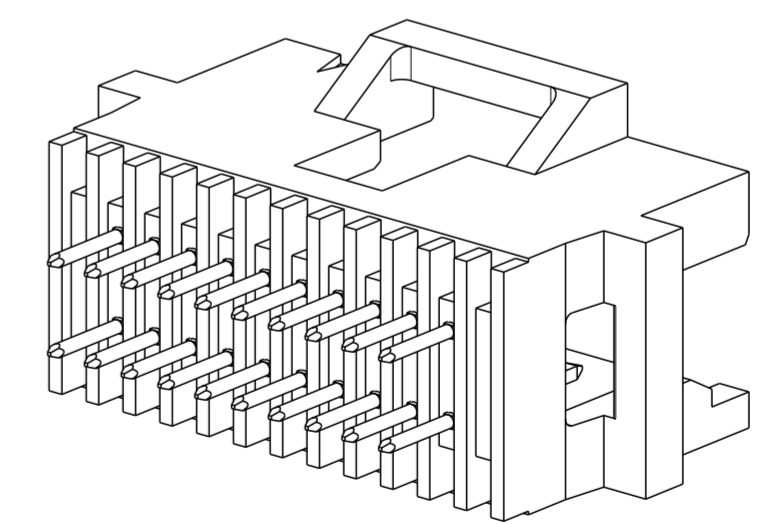

THIS DRAWING IS A CONTROLLED DOCUMENT.		DWN RAVI.S 18MAY2017	TE Connectivity		
DIMENSIONS: mm		CHK J. OLSON 18MAY2017			
TOLERANCES UNLESS OTHERWISE SPECIFIED:		APVD J. OLSON 18MAY2017	NAME HEADER ASSEMBLY, VERTICAL, DOUBLE ROW, W/SIDE & END LATCHES, AMPMODU System 50		
0 PLC ±0.3		PRODUCT SPEC 108-1093	SIZE A2		
1 PLC ±0.13		APPLICATION SPEC 114-25031	CAGE CODE -		
2 PLC ±		WEIGHT -	DRAWING NO C-104068		
3 PLC ±		CUSTOMER DRAWING	RESTRICTED TO -		
4 PLC ANGLES ±1°		SCALE 5:1	SHEET 1 OF 2		
FINISH SEE TABLE		REV R1			

THIS DRAWING IS UNPUBLISHED. RELEASED FOR PUBLICATION
 © COPYRIGHT copyright.dBTe ALL RIGHTS RESERVED.

REVISIONS				
P	LTR	DESCRIPTION	DATE	APVD
-		SEE SHEET 1	-	-

FINISH	DIM_C	B SPACES	DIM_E	NO OF POSN	PART NUMBER	FINISH	DIM_C	B SPACES	DIM_E	NO OF POSN	PART NUMBER
9	41.91	33	46.48	68	8-104068-8	8	41.91	33	46.48	68	3-104068-8
	62.23	49	66.80	100	8-104068-7		62.23	49	66.80	100	3-104068-7
	49.53	39	54.10	80	8-104068-6		49.53	39	54.10	80	3-104068-6
	44.45	35	49.02	72	8-104068-5		44.45	35	49.02	72	3-104068-5
	26.67	21	31.24	44	8-104068-4		26.67	21	31.24	44	3-104068-4
	20.32	16	24.89	34	8-104068-3		20.32	16	24.89	34	3-104068-3
	15.24	12	19.81	26	8-104068-2		15.24	12	19.81	26	3-104068-2
	13.97	11	18.54	24	8-104068-1		13.97	11	18.54	24	3-104068-1
	8.89	7	13.46	16	8-104068-0		8.89	7	13.46	16	3-104068-0
	7.62	6	12.19	14	7-104068-9		7.62	6	12.19	14	2-104068-9
	6.35	5	10.92	12	7-104068-8		6.35	5	10.92	12	2-104068-8
	3.81	3	8.38	8	7-104068-7		3.81	3	8.38	8	2-104068-7
	36.83	29	41.40	60	7-104068-6		36.83	29	41.40	60	2-104068-6
	30.48	24	35.05	50	7-104068-5		30.48	24	35.05	50	2-104068-5
	24.13	19	28.70	40	7-104068-4		24.13	19	28.70	40	2-104068-4
	17.78	14	22.35	30	7-104068-3		17.78	14	22.35	30	2-104068-3
	5.08	4	9.65	10	7-104068-2		5.08	4	9.65	10	2-104068-2
	11.43	9	16.00	20	7-104068-1		11.43	9	16.00	20	2-104068-1
	41.91	33	46.48	68	6-104068-8		41.91	33	46.48	68	1-104068-8
	62.23	49	66.80	100	6-104068-7		62.23	49	66.80	100	1-104068-7
	49.53	39	54.10	80	6-104068-6		49.53	39	54.10	80	1-104068-6
	44.45	35	49.02	72	6-104068-5		44.45	35	49.02	72	1-104068-5
	26.67	21	31.24	44	6-104068-4		26.67	21	31.24	44	1-104068-4
	20.32	16	24.89	34	6-104068-3		20.32	16	24.89	34	1-104068-3
	15.24	12	19.81	26	6-104068-2		15.24	12	19.81	26	1-104068-2
	13.97	11	18.54	24	6-104068-1		13.97	11	18.54	24	1-104068-1
	8.89	7	13.46	16	6-104068-0		8.89	7	13.46	16	1-104068-0
	7.62	6	12.19	14	5-104068-9		7.62	6	12.19	14	104068-9
	6.35	5	10.92	12	5-104068-8		6.35	5	10.92	12	104068-8
	3.81	3	8.38	8	5-104068-7		3.81	3	8.38	8	104068-7
	36.83	29	41.40	60	5-104068-6		36.83	29	41.40	60	104068-6
	30.48	24	35.05	50	5-104068-5		30.48	24	35.05	50	104068-5
	24.13	19	28.70	40	5-104068-4		24.13	19	28.70	40	104068-4
	17.78	14	22.35	30	5-104068-3		17.78	14	22.35	30	104068-3
	5.08	4	9.65	10	5-104068-2		5.08	4	9.65	10	104068-2
	11.43	9	16.00	20	5-104068-1		11.43	9	16.00	20	104068-1

THIS DRAWING IS A CONTROLLED DOCUMENT.

DWN	RAVLS	18MAY2017	 TE Connectivity					
CHK	J. OLSON	18MAY2017						
APVD	J. OLSON	18MAY2017						
NAME	HEADER ASSEMBLY, VERTICAL, DOUBLE ROW, W/SIDE & END LATCHES, AMPMODU System 50							
PRODUCT SPEC	108-1093		SIZE	CAGE CODE	DRAWING NO	RESTRICTED TO		
APPLICATION SPEC	114-25031		A2	-	G-104068	-		
MATERIAL	SEE TABLE		WEIGHT	CUSTOMER DRAWING		SCALE	4:1	
			SHEET	2	OF	2	REV	RI

Mouser Electronics

Authorized Distributor

Click to View Pricing, Inventory, Delivery & Lifecycle Information:

[TE Connectivity:](#)

[104068-5](#)