

High-Voltage MIL-COTS Input Filter Module

Features & Benefits

- 270V nominal input
- 99% efficiency
- EMI filtering
 - MIL-STD-461E/F/G, selected CE and CS tests
- Input transient protection
 - MIL-STD-704F
normal and abnormal transients
- Environmental qualification
 - MIL-STD-810
 - MIL-STD-202
- Low M-Grade temperature rating, providing operation down to -55°C
- Output power up to 640W
- Available in chassis and PCB mount
- Small size
 - 1.76 x 1.40 x 0.36in
[44.6 x 35.5 x 9.2mm]

Typical Applications

- Defense
- Aerospace

Compatible Products

- High input voltage DCM3714 VIA™
- High input voltage ChiP^[a] DCM

Product Description

The MFM DCM™ Filter is a DC front-end module that provides EMI filtering and transient protection. The MFM DCM Filter enables designers using Vicor 270V nominal input voltage VIA™ or ChiP™^[a] modules to meet conducted emission/conducted susceptibility per MIL-STD-461E/F/G; and input transients per MIL-STD-704F. The MFM DCM Filter accepts an input voltage of 160 – 420V_{DC} (270V nominal input) and delivers output power up to 640W.



Size:
1.76 x 1.40 x 0.36in
[44.6 x 35.5 x 9.2mm]

^[a] Additional components are required for EMI filtering and transient suppression, when used with ChiP™ package modules.

Part Ordering Information

Part Number	Package Type	Product Grade	Option Field
MFM1714BD2KD2F4M04	B = Board VIA	M = -55 to 100°C	04 = Short Pin
MFM1714BD2KD2F4M08			08 = Long Pin
MFM1714VD2KD2F4M00	V = Chassis VIA		00 = Chassis

Typical Application

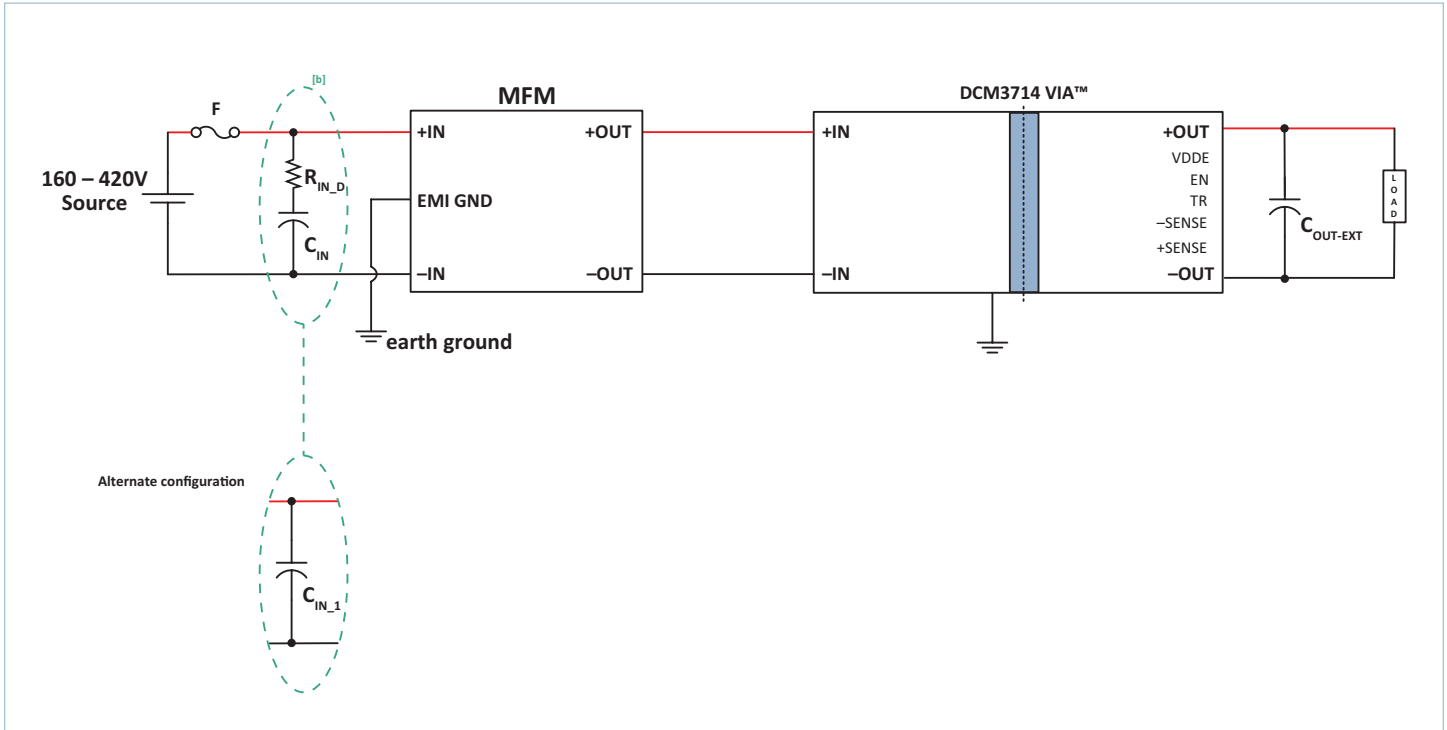

DCM3714 VIA™ with a MFM input filter, to meet the MIL-STD-461E/F/G requirements

Parts List for Typical Application	
F	Littelfuse 0487 Series rated 8A Cooper/Bussman PC-Tron Series, fast acting fuses rated 5A
R _{IN_D}	Vishay Dale CRCW25123R30FKEG, 3.3Ω, 1W
C _{IN} ^[b]	TDK Corporation C5750X6S2W225K250KA, 5 x 2.2μF (11μF)
Parts List for Alternate Configuration	
C _{IN_1} ^[c]	Rubycon 450QXW100MEFC16X35, 100μF, 450V

^[b] A minimum load of 10% is required to meet the conducted emissions CE102 for input voltages in the range of 270 – 420V_{DC}. For EMI test report, contact Vicor Applications.

^[c] No minimum load is required to meet CE102 with C_{IN_1} = 100μF.

Pin Configuration

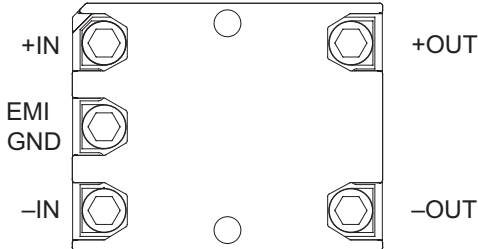

MFM1714 Filter – Chassis (Lug) Mount – Terminals Up

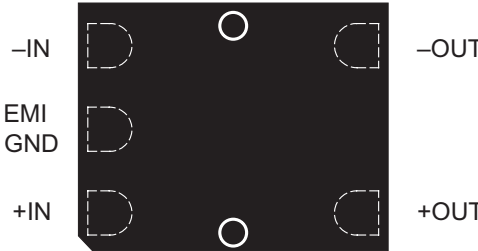

MFM1714 Filter – PCB Mount – Pins Down

Note: These pin drawings are not to scale.

Pin Descriptions

Signal Name	Type	Function
+IN	INPUT POWER	Positive input power terminal
-IN	INPUT POWER RETURN	Negative input power terminal
EMI GND	EMI GROUND	EMI ground terminal
+OUT	OUTPUT POWER	Positive output power terminal
-OUT	OUTPUT POWER RETURN	Negative output power terminal

Absolute Maximum Ratings

The absolute maximum ratings below are stress ratings only. Operation at or beyond these maximum ratings can cause permanent damage to the device. Electrical specifications do not apply when operating beyond rated operating conditions.

Parameter	Comments	Min	Max	Unit
Input Voltage (+IN to –IN)	Continuous	–0.5	460.0	V
Output Voltage (+OUT to –OUT)	Continuous	–0.5	460.0	V
Dielectric Withstand (Input/Output to EMI GND/Case)			2121	V _{DC}
Storage Temperature	M-Grade	–65	125	°C
Internal Operating Temperature	M-Grade	–55	125	°C
Average Output Current			4	A
Input/Output Pin Torque and Mounting Torque			4 [0.45]	in·lbs [N·m]

Electrical Specifications

Specifications apply over all line and load conditions, unless otherwise noted; **boldface** specifications apply over the temperature range of $-55^{\circ}\text{C} \leq T_{\text{CASE}} \leq 100^{\circ}\text{C}$ (M-Grade); all other specifications are at $T_{\text{CASE}} = 25^{\circ}\text{C}$ unless otherwise noted.

Attribute	Symbol	Conditions / Notes	Min	Typ	Max	Unit
Power Input / Output Specification						
Input Voltage Range	V _{IN}	Continuous operation	160	270	420	V
Maximum Output Current ^[d]	I _{OUT_MAX}	Continuous, at V _{OUT} = 160V (I _{OUT} = P _{OUT} /V _{IN})			4	A
Rated Output Power ^[d]	P _{OUT}	Continuous, over all line conditions			640	W
Internal Voltage Drop		@270V, 2.37A, 100°C baseplate			0.80	V _{DC}
Efficiency	η	Full load, low line, high temperature	99.4	99.6	99	%
		Full load, nominal line, high temperature	99.7	99.8		%
		Full load, high line, high temperature	99.8	99.9		%

^[d] One MFM for each DCM™ even if the total power of the DCM is below P_{OUT} maximum value.

EMI/EMC

Standard	Test Procedure	Notes
MIL-STD-461E/F/G		
Conducted Emmissions	CE101	Figure CE101-4, Navy ASW & Army Aircraft, Curve #1 (above 28V _{DC})
	CE102	Figure CE102-1, Basic curve + 10dB limit relaxation for all applications
Conducted Susceptibility	CS101	Figure CS101, Curve #1, for all applications (above 28V _{DC})
MIL-HDBK-704-7		
Transient Immunity	MIL-STD-704F normal transients	From table HDC105-III: overvoltage 330V _{DC} for 20ms duration, undervoltage 200V _{DC} for 50ms duration
	MIL-STD-704F abnormal transients	From table HDC302-III: overvoltage 350V _{DC} for 50ms duration, undervoltage 180V _{DC} for 50ms duration

Typical Characteristics

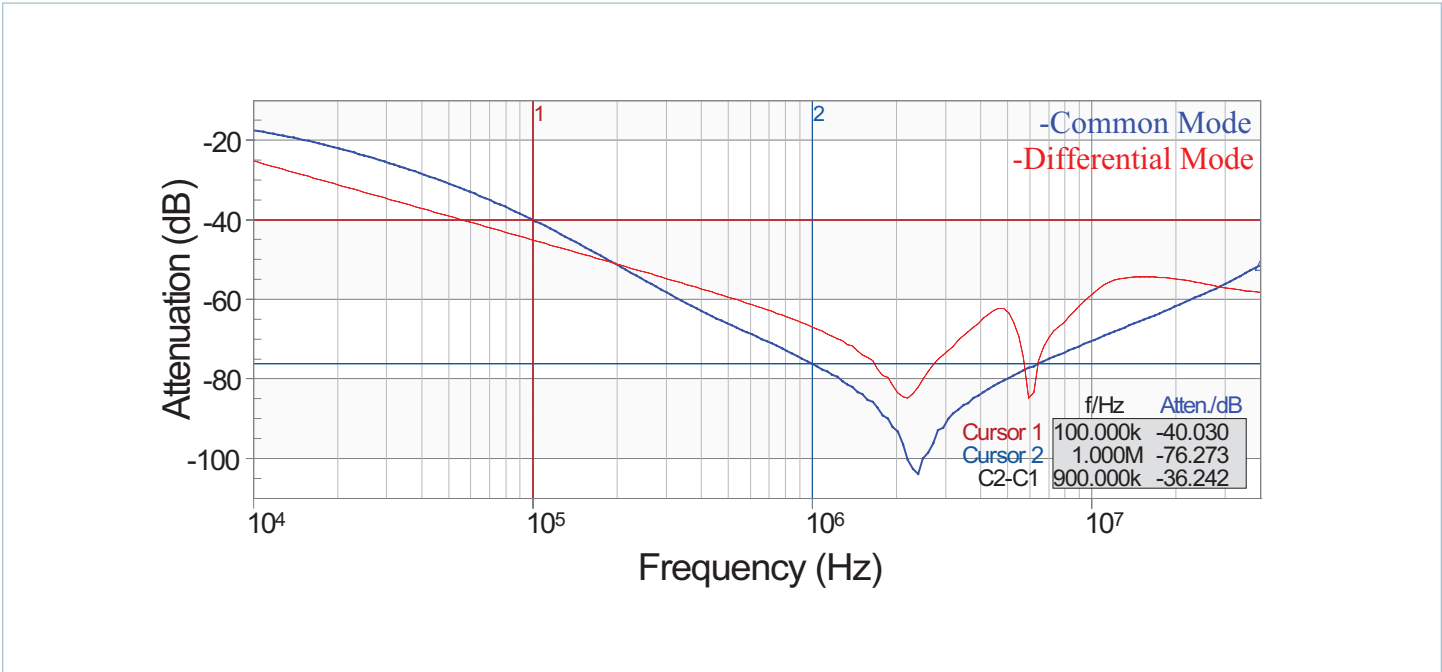

Figure 1 — Attenuation (dB) vs. frequency (Hz), input leads are terminated with LISN impedances 25Ω for common mode, 100Ω for differential mode

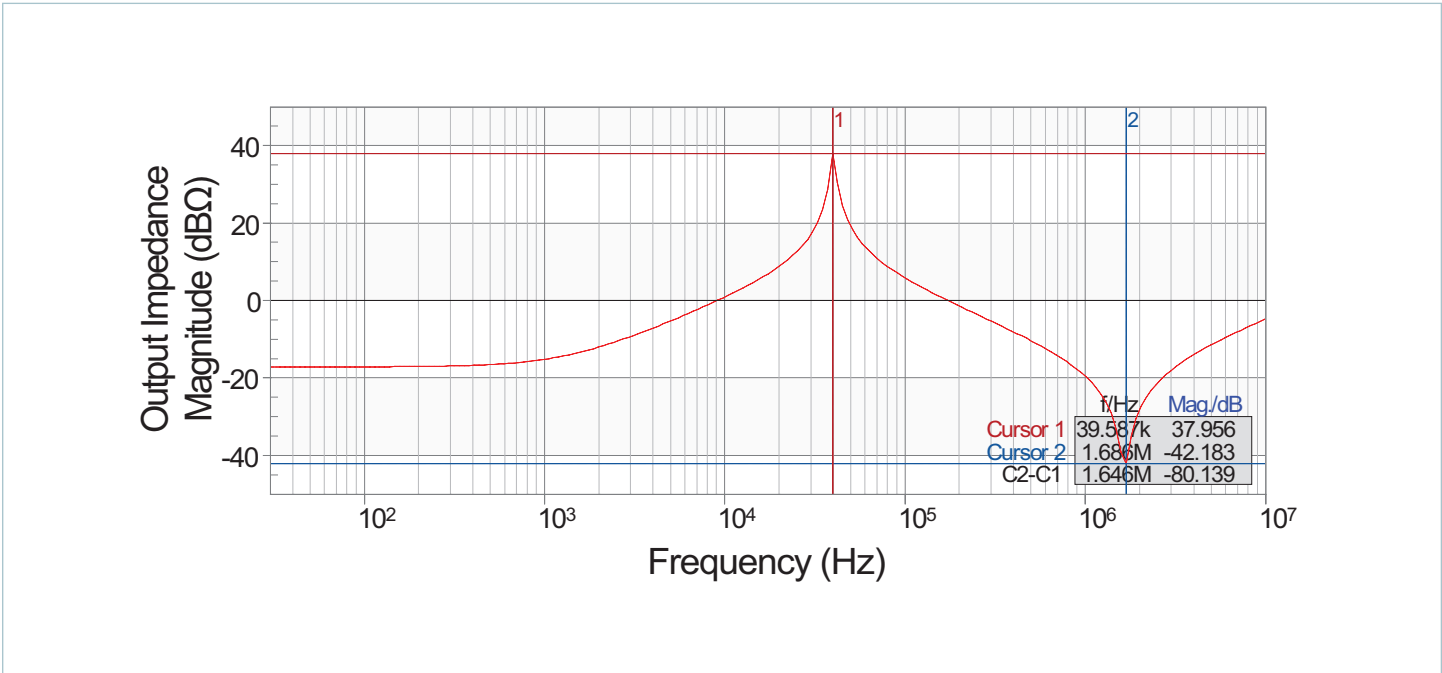

Figure 2 — Output Impedance (dBΩ) vs. frequency (Hz) plot looking back into the output terminals of the MFM with shorted input terminals

Typical Conducted Emissions

CE101 peak scans with MFM1714VD2KD2F4M00 and DCM3714VD2K26E0M01 or DCM3714VD2K31E0T01, in either condition:
 -OUT connected to GND or -OUT floating.

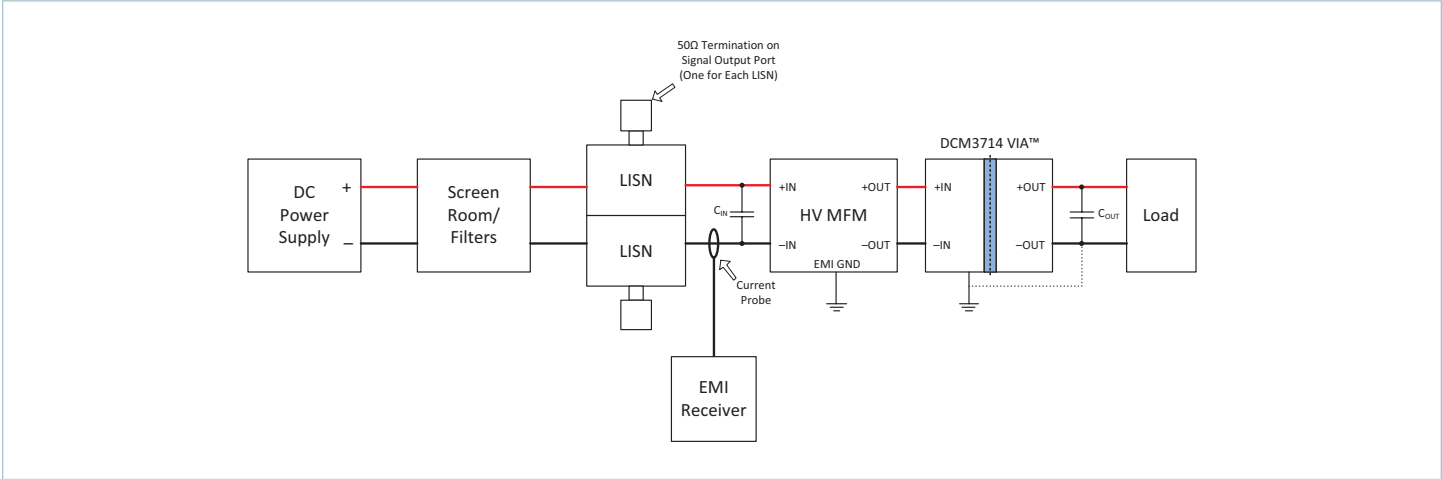

Figure 3 — A typical test setup for conducted emissions CE101 is shown above. A current probe is used to measure and plot the variations in the current through the RED and BLACK leads at various load conditions.

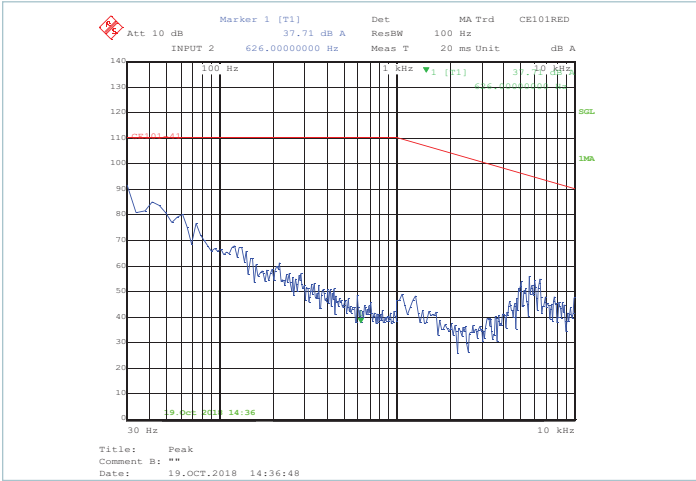

Figure 4 — Peak scan for the RED lead with $C_{IN} = 11\mu F$, $R_{IN_D} = 3.3\Omega$ $C_{OUT} = 2200\mu F$, 0% load, $V_{IN} = 160V$

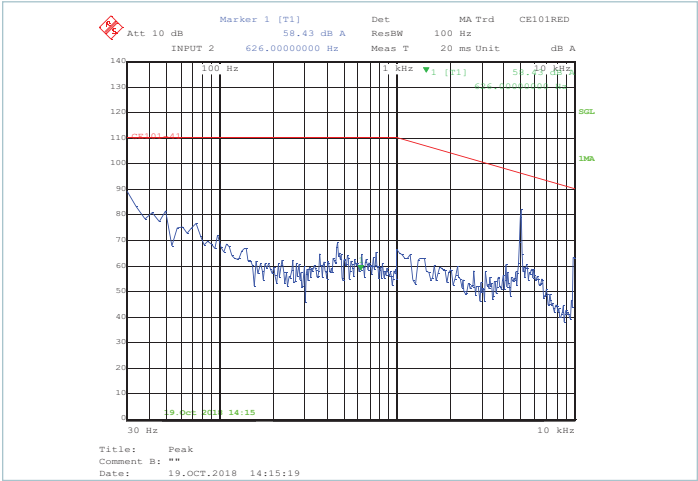

Figure 5 — Peak scan for the RED lead with $C_{IN} = 11\mu F$, $R_{IN_D} = 3.3\Omega$ $C_{OUT} = 2200\mu F$, 100% load, $V_{IN} = 160V$

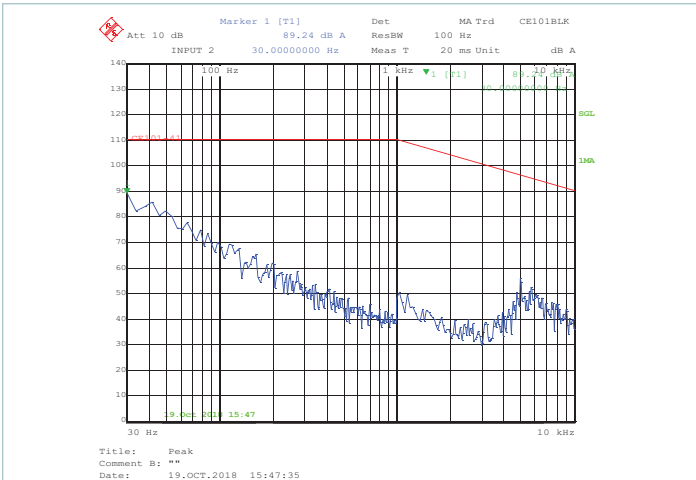

Figure 6 — Peak scan for the BLACK lead with $C_{IN} = 11\mu F$, $R_{IN_D} = 3.3\Omega$ $C_{OUT} = 2200\mu F$, 0% load, $V_{IN} = 160V$

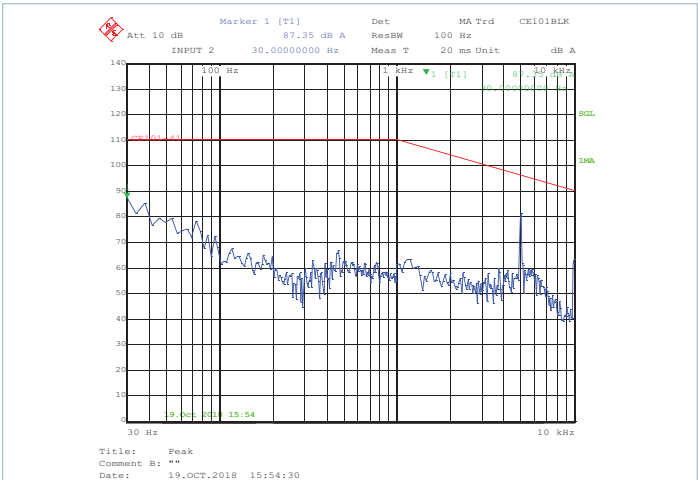

Figure 7 — Peak scan for the BLACK lead with $C_{IN} = 11\mu F$, $R_{IN_D} = 3.3\Omega$ $C_{OUT} = 2200\mu F$, 100% load, $V_{IN} = 160V$

Typical Conducted Emissions (Cont.)

CE101 peak scans with MFM1714VD2KD2F4M00 and DCM3714VD2K26E0M01 or DCM3714VD2K31E0T01, in either condition:
-OUT connected to GND or -OUT floating.

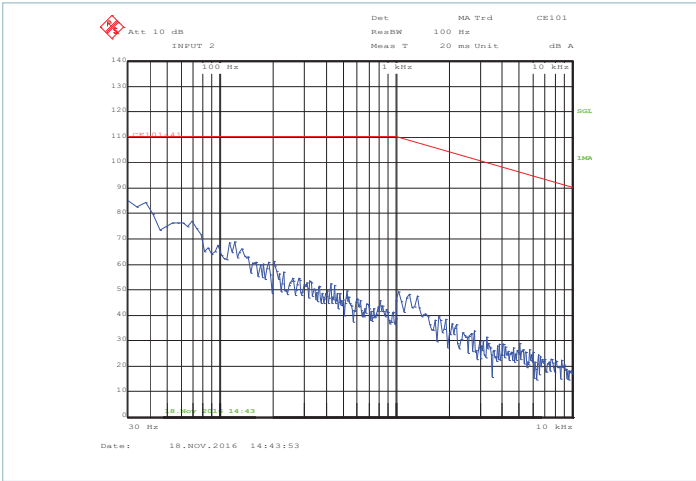

Figure 8 — Peak scan for the RED lead with $C_{IN_1} = 100\mu F$, $C_{OUT} = 2000\mu F$, 0% load

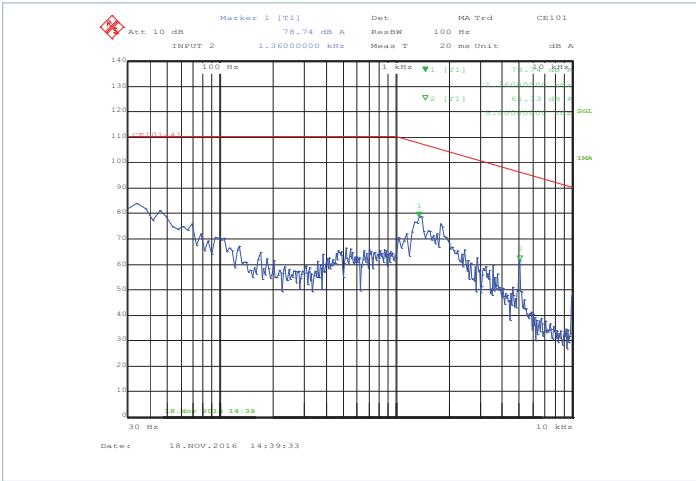

Figure 9 — Peak scan for the RED lead with $C_{IN_1} = 100\mu F$, $C_{OUT} = 2000\mu F$, 100% load

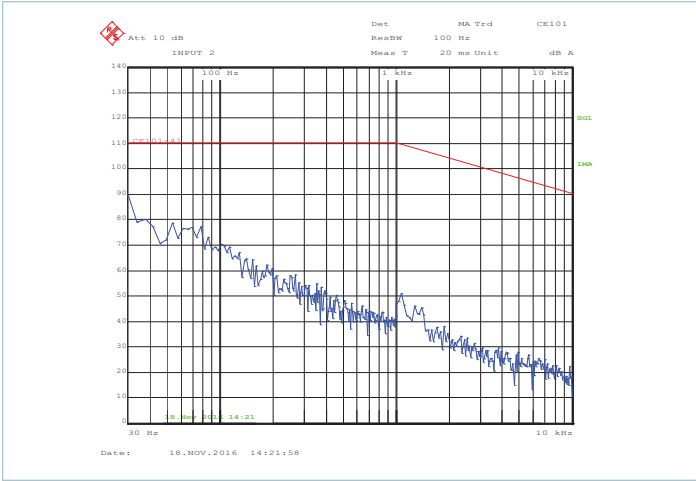

Figure 10 — Peak scan for the BLACK lead with $C_{IN_1} = 100\mu F$, $C_{OUT} = 2000\mu F$, 0% load

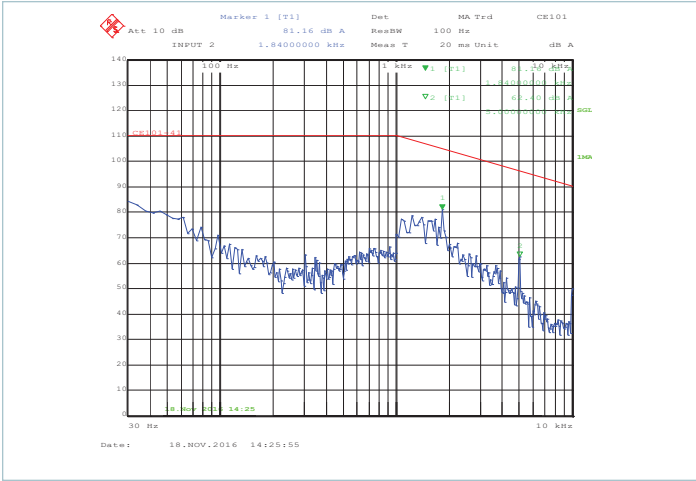

Figure 11 — Peak scan for the BLACK lead with $C_{IN_1} = 100\mu F$, $C_{OUT} = 2000\mu F$, 100% load

Typical Conducted Emissions (Cont.)

CE102 peak scans with MFM1714VD2KD2F4M00 and DCM3714VD2K26E0M01 or DCM3714VD2K31E0T01, -OUT connected to GND, -OUT is floating.

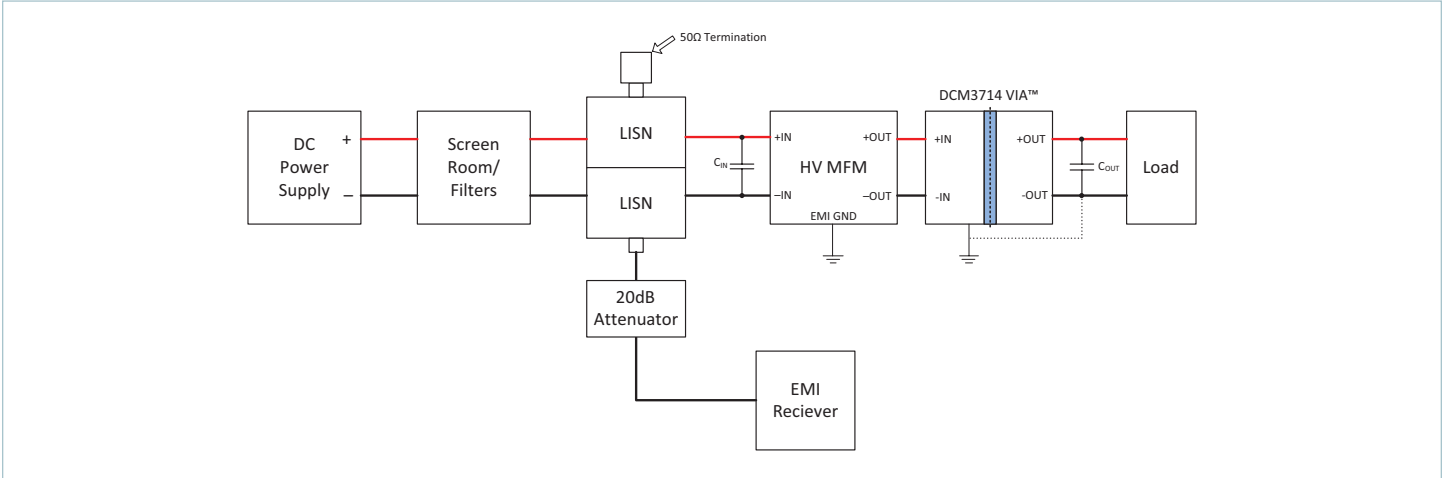

Figure 12 — A typical test setup for conducted emissions CE102 is shown above. A 50Ω termination is used for LISN and voltage across the RED and BLACK leads are measured at various load conditions.

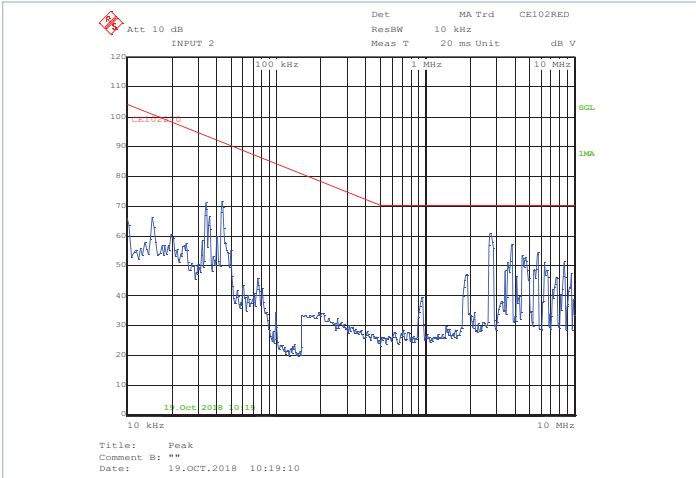

Figure 13 — Peak scan for the RED lead with $C_{IN} = 11\mu F$, $R_{IN,D} = 3.3\Omega$ $C_{OUT} = 2200\mu F$, 0% load, $V_{IN} = 160V$

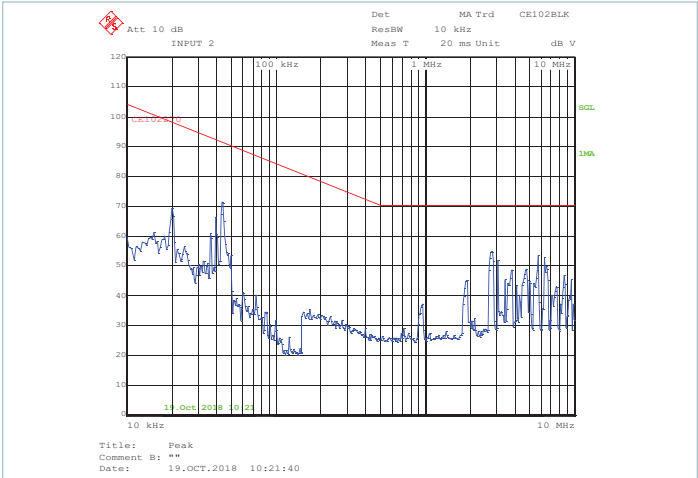

Figure 14 — Peak scan for the RED lead with $C_{IN} = 11\mu F$, $R_{IN,D} = 3.3\Omega$ $C_{OUT} = 2200\mu F$, 100% load, $V_{IN} = 160V$

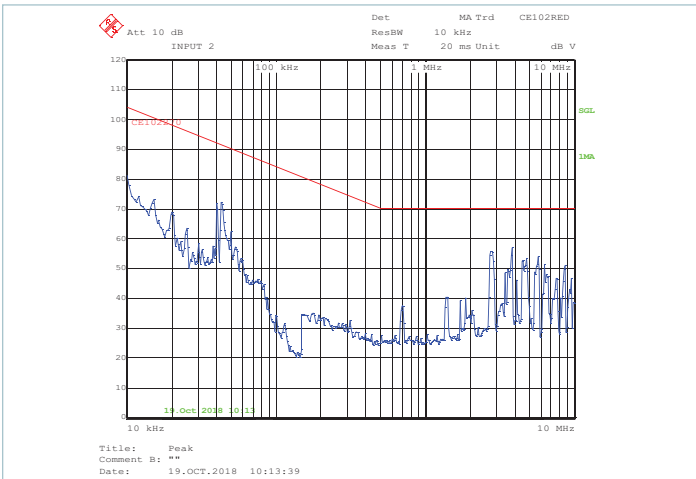

Figure 15 — Peak scan for the BLACK lead with $C_{IN} = 11\mu F$, $R_{IN,D} = 3.3\Omega$ $C_{OUT} = 2200\mu F$, 0% load, $V_{IN} = 160V$

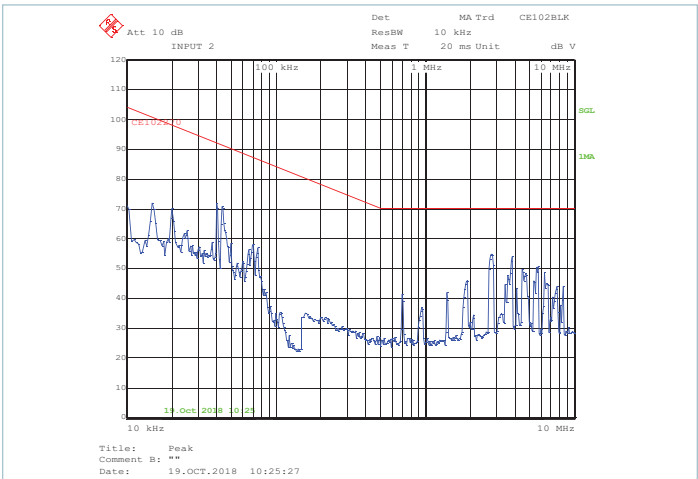

Figure 16 — Peak scan for the BLACK lead with $C_{IN} = 11\mu F$, $R_{IN,D} = 3.3\Omega$ $C_{OUT} = 2200\mu F$, 100% load, $V_{IN} = 160V$

Note: A minimum load of 10% is required to meet the conducted emissions CE102 for input voltages in the range of 270 – 420V_{DC}. For EMI test report, contact Vicor Applications.

Typical Conducted Emissions (Cont.)

CE102 peak scans with MFM1714VD2KD2F4M00 and DCM3714VD2K26E0M01 or DCM3714VD2K31E0T01, -OUT connected to GND, -OUT is floating.

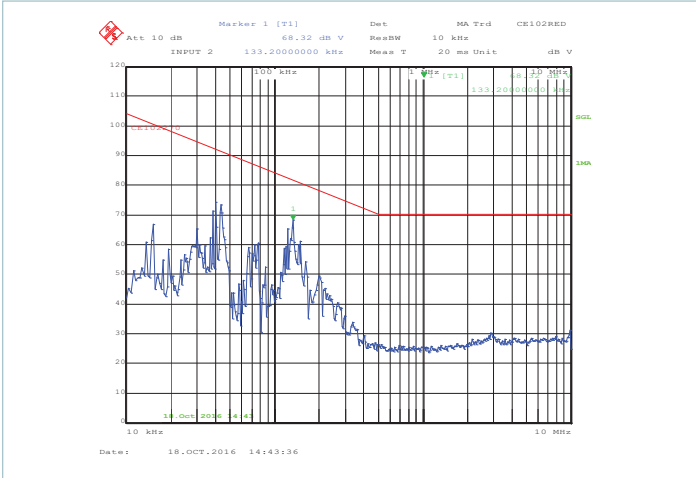

Figure 17 — Peak scan for the RED lead with $C_{IN_1} = 100\mu F$, $C_{OUT} = 2000\mu F$, 0% load

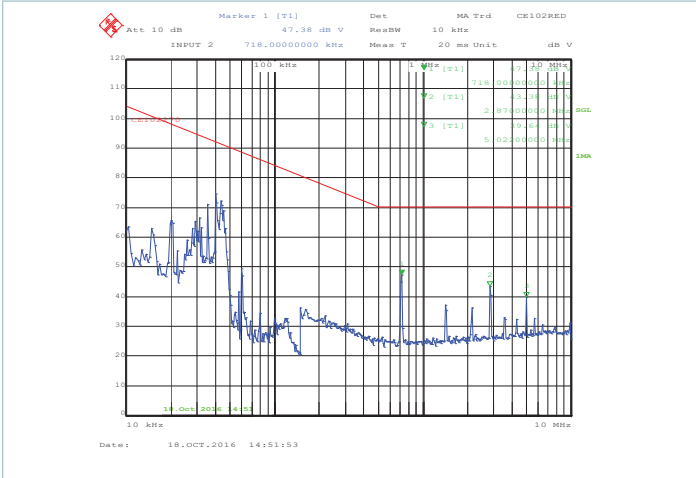

Figure 18 — Peak scan for the RED lead with $C_{IN_1} = 100\mu F$, $C_{OUT} = 2000\mu F$, 100% load

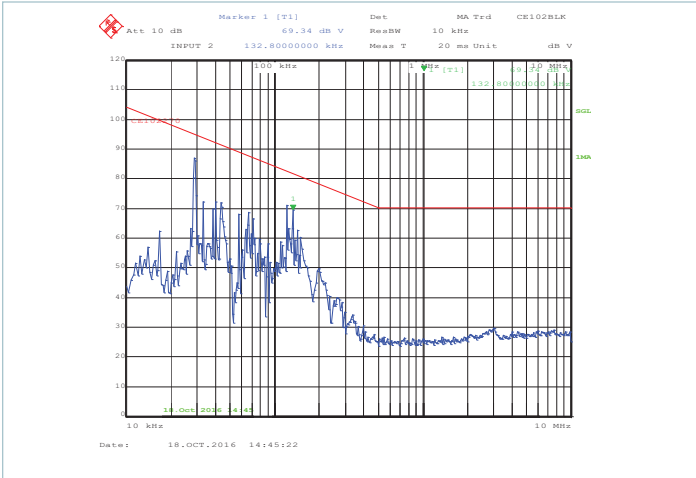

Figure 19 — Peak scan for the BLACK lead with $C_{IN_1} = 100\mu F$, $C_{OUT} = 2000\mu F$, 0% load

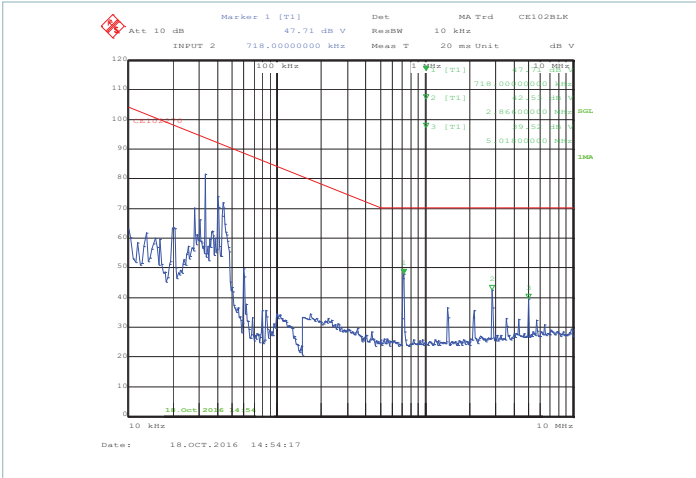

Figure 20 — Peak scan for the BLACK lead with $C_{IN_1} = 100\mu F$, $C_{OUT} = 2000\mu F$, 100% load

Note: No minimum load is required to meet CE102 with $C_{IN_1} = 100\mu F$.

General Characteristics

Specifications apply over all line and load conditions, $T_{INT} = 25^{\circ}\text{C}$, unless otherwise noted; **boldface** specifications apply over the temperature range of the specified product grade.

Attribute	Symbol	Conditions / Notes	Min	Typ	Max	Unit
Mechanical						
Length	L			44.6 [1.76]		mm [in]
Width	W			35.5 [1.39]		mm [in]
Height	H			9.22 [0.36]		mm [in]
Volume	Vol			14.5 [0.88]		cm ³ [in ³]
Mass (Weight)	M			30 [1.06]		g [oz]
Pin Material		C145 copper, 1/2 hard				
Underplate		Low-stress ductile Nickel	50		100	μin
Pin Finish		Palladium	0.8		6	μin
		Soft Gold	0.12		2	
Flatness					<0.25 [0.010]	mm [in]
Thermal						
Internal Operating Temperature ^[e]		M-Grade	-55		125	°C
Case Temperature		M-Grade	-55		100	
Thermal Resistance, Internal to Case Non-Pin Side	$\theta_{INT_NON_PIN_SIDE}$			6.5		°C/W
Soldering						
Temperature		See: AN:401 PCB Mount VIA Soldering Guidelines				
Reliability						
MTBF		MIL-HDBK-217FN2 Parts Count - 25°C Ground Benign, Stationary, Indoors / Computer	60			MHrs
Safety						
Dielectric Withstand		Input / Output to EMI GND/Case	2121			V _{DC}
Agency Approvals / Standards						
		CE marked for Low Voltage Directive (LVD) 2014/35/EU, EN60950-1				

^[e] Internal operating temperatures will be kept to acceptable limits if the lower housing of the unit is mounted to a metal plate (coldplate or heat sink) with thermal grease that is kept to 100°C or less. If the unit is not mounted to a metal plate, then a thermocouple on the non-pin-side housing located midway between the two mounting holes needs to be kept to 100°C or less.

Environmental Qualification

Testing Activity	Reference Standard	Test Details
HTOB-HTOL High-Temperature Operating Bias/Life	JESD22-A110-B	Duration of 1000hrs, high Line, full load, max operating temperature, power cycled per IPC9592
TC (Temperature Cycling)	JESD22-A104D	1000 cycles -55 to 125°C
HALT (Highly Accelerated Life Test)	DP-0266	Low temp, high temp, rapid thermal cycling, random vibration test, combined stress test
THB (Temperature Humidity Bias)	JESD22-A101C	Duration of 1000hrs, biased, 85°C, 85%RH
HTS (High Temperature Storage)	JESD 22-A103-D	Duration 1000hrs, no bias. Maximum storage temperature (125°C)
LTS (Low Temperature Storage)	JESD22-A119	Duration 1000hrs, no bias. Minimum storage temperature (-65°C)
Random Vibration	MIL-STD-810G	Method 514.6, Procedure I, Category 24, mounted on QA
Mechanical Shock	MIL-STD-810G	Method 516.5, Procedure I, Environment: functional shock 40G, mounted on QA
Electro Static Discharge Human Body Model	JEDEC JS-001-2012	Table 2B, Class 2, ±2000V minimum
Electro Static Discharge Device Charge Model	JESD22-C101-E	Class III ±500V minimum
Free Fall	IPC9592B	IEC 60068-2-32, freefall procedure 1
Term Strength	MIL-STD-202G	Method 211A, Test Condition A, Environment: Ambient temperature & %Rh.
Through-Hole Solderability	IPC-9592B	IPC/ECA J-STD-002 Test A (dip and look)
Salt Fog	MIL-STD-810G	Method 509.5
Fungus	MIL-STD-810G	Method 508.6
Resistance to Solvents	MIL-STD-202G	Method 215K
Acceleration	MIL-STD-810G	Method 513.6 Procedure II
Altitude	MIL-STD-810G	Method 500.5 Procedure I & II
Explosive Atmosphere	MIL-STD-810G	Method 511.5 Procedure I, operational

Chassis-Mount Outline Drawing

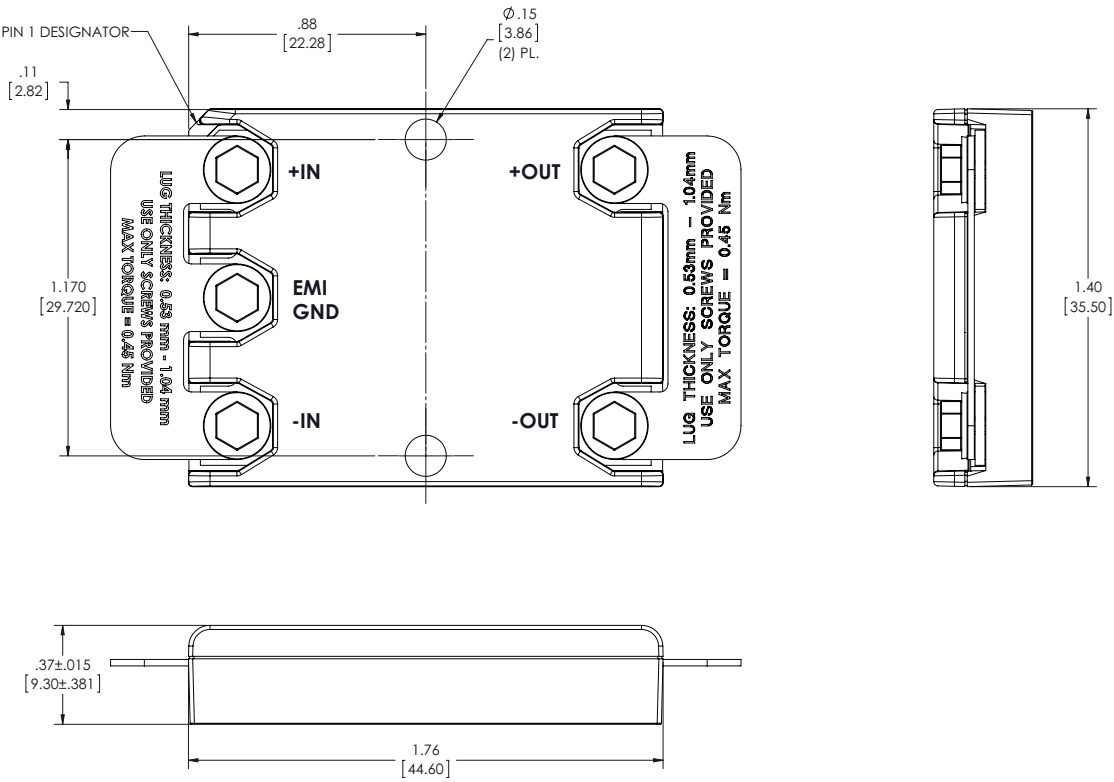

UNLESS OTHERWISE SPECIFIED DIMENSIONS ARE: INCH [MM]

Board-Mount Outline Drawing

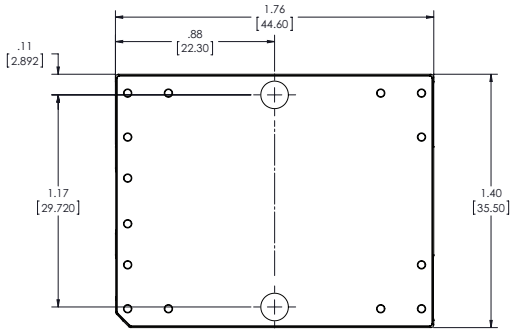

TOP VIEW (COMPONENT SIDE)

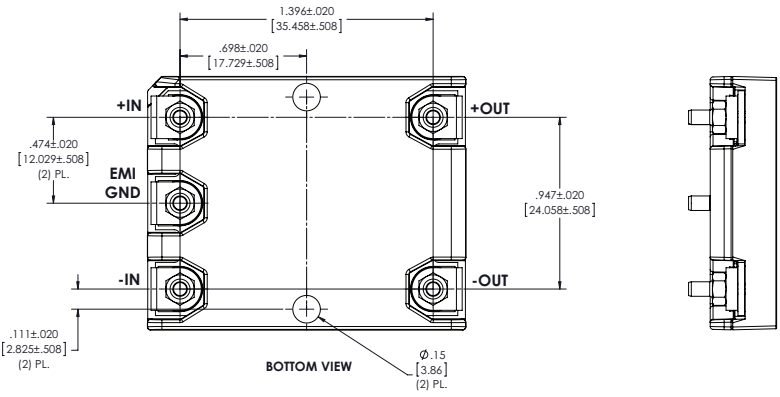
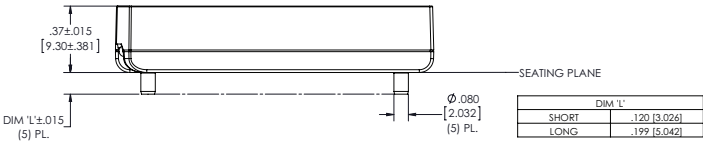

BOTTOM VIEW

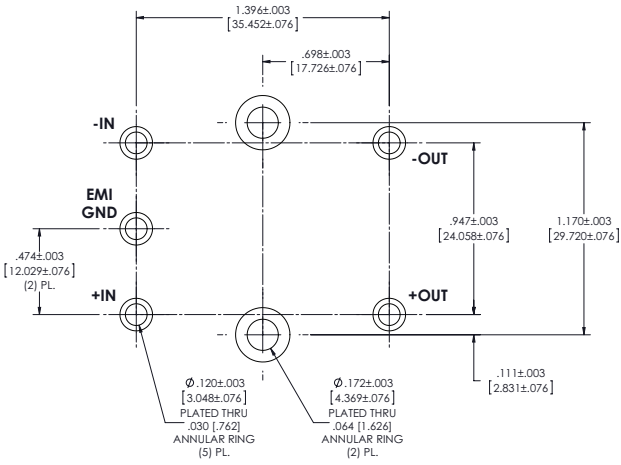

RECOMMENDED HOLE PATTERN (COMPONENT SIDE)

UNLESS OTHERWISE SPECIFIED DIMENSIONS ARE: INCH [MM]

Revision History

Revision	Date	Description	Page Number(s)
1.0	02/13/17	Initial release	n/a
1.1	06/15/17	Updated product image	7, 8
1.2	07/26/17	Added fuse recommendation for typical application & removed MOV Updated internal operating temperature Updated note on CE scans for -OUT floating Updated MTBF rating	2 4 7, 8 9
1.3	07/24/18	Updated mechanical drawings	11, 12
1.4	10/26/18	Updated typical application Updated typical conducted emissions	2 7 – 10
1.5	03/31/20	Updated MIL-STD-461 to the latest revision	1, 2, 5

Note: pages added in Rev 1.4

Vicor's comprehensive line of power solutions includes high density AC-DC and DC-DC modules and accessory components, fully configurable AC-DC and DC-DC power supplies, and complete custom power systems.

Information furnished by Vicor is believed to be accurate and reliable. However, no responsibility is assumed by Vicor for its use. Vicor makes no representations or warranties with respect to the accuracy or completeness of the contents of this publication. Vicor reserves the right to make changes to any products, specifications, and product descriptions at any time without notice. Information published by Vicor has been checked and is believed to be accurate at the time it was printed; however, Vicor assumes no responsibility for inaccuracies. Testing and other quality controls are used to the extent Vicor deems necessary to support Vicor's product warranty. Except where mandated by government requirements, testing of all parameters of each product is not necessarily performed.

Specifications are subject to change without notice.

Visit <http://www.vicorpower.com/mil-cots-dc-dc/mfm-filter-module> for the latest product information.

Vicor's Standard Terms and Conditions and Product Warranty

All sales are subject to Vicor's Standard Terms and Conditions of Sale, and Product Warranty which are available on Vicor's webpage (<http://www.vicorpower.com/termsconditionswarranty>) or upon request.

Life Support Policy

VICOR'S PRODUCTS ARE NOT AUTHORIZED FOR USE AS CRITICAL COMPONENTS IN LIFE SUPPORT DEVICES OR SYSTEMS WITHOUT THE EXPRESS PRIOR WRITTEN APPROVAL OF THE CHIEF EXECUTIVE OFFICER AND GENERAL COUNSEL OF VICOR CORPORATION. As used herein, life support devices or systems are devices which (a) are intended for surgical implant into the body, or (b) support or sustain life and whose failure to perform when properly used in accordance with instructions for use provided in the labeling can be reasonably expected to result in a significant injury to the user. A critical component is any component in a life support device or system whose failure to perform can be reasonably expected to cause the failure of the life support device or system or to affect its safety or effectiveness. Per Vicor Terms and Conditions of Sale, the user of Vicor products and components in life support applications assumes all risks of such use and indemnifies Vicor against all liability and damages.

Intellectual Property Notice

Vicor and its subsidiaries own Intellectual Property (including issued U.S. and Foreign Patents and pending patent applications) relating to the products described in this data sheet. No license, whether express, implied, or arising by estoppel or otherwise, to any intellectual property rights is granted by this document. Interested parties should contact Vicor's Intellectual Property Department.

The products described on this data sheet are protected by the following U.S. Patents Numbers:
Patents Pending.

Contact Us: <http://www.vicorpower.com/contact-us>

Vicor Corporation
25 Frontage Road
Andover, MA, USA 01810
Tel: 800-735-6200
Fax: 978-475-6715
www.vicorpower.com

email

Customer Service: custserv@vicorpower.com
Technical Support: apps@vicorpower.com

Mouser Electronics

Authorized Distributor

Click to View Pricing, Inventory, Delivery & Lifecycle Information:

Vicor:

[MFM1714BD2KD2F4M04](#) [MFM1714BD2KD2F4M08](#) [MFM1714VD2KD2F4M00](#)