

## NH-AAA1100AR

## Ni-MH Battery

### Dimensions

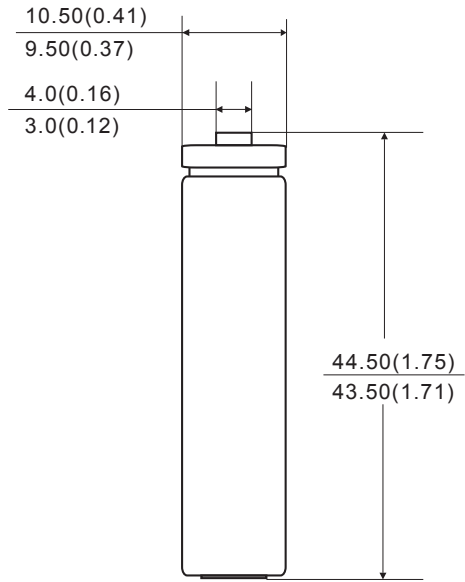

Unit:mm(inch)

### Specifications

Chemical System:	Nickel Metal Hydride
IEC Name:	HR03M
ANSI/NEDA:	1.2H1(AAA)
Camelion Model:	NH-AAA1100AR
Average Weight:	12.5g
Dimension(Ø x H ):	10.0 <sup>±0.5</sup> x 44.0 <sup>±0.5</sup> mm 0.39 <sup>±0.02</sup> x 1.73 <sup>±0.02</sup> inch
Terminals:	Flat
Nominal Voltage:	1.2Volts
Internal Resistance:	45m-ohm
Capacity(160mA constantly discharge to 1.0V at 25±2°C)	
Minimum:	950mAh
Typical:	1100mAh
Operating Temperature:	-10°C-50°C
Storage Temperature:	15°C-25°C
Relative Humidity:	60±15%

### Usage Guide



Shaver



Toy



Digital Still Camera

### Cautions

#### Storage

Store the battery in a cool, dry and well-ventilated area.

#### Handling

- 1) Do not heat or disposed in fire or water. Do not modify or disassemble the battery. Do not short-circuit positive (+) and negative (-) terminals.  
Keep away from metal or other conductive materials.
- 2) Keep away from infants. If infant happens to swallow the battery, consult a doctor immediately.
- 3) When the battery is stored or disposed, isolate positive (+) and negative (-) terminals of the battery to avoid those terminals touch each other.
- 4) In case the battery electrolyte happen to come into mouth,gargle well enough and consult a doctor immediately.

## NH-AAA1100AR

## Ni-MH Battery

### Storage for 24months

Measurement temperature:  $20 \pm 2^\circ\text{C}$

Storage procedure: storage for 24months, measure the voltage and then perform capacity test

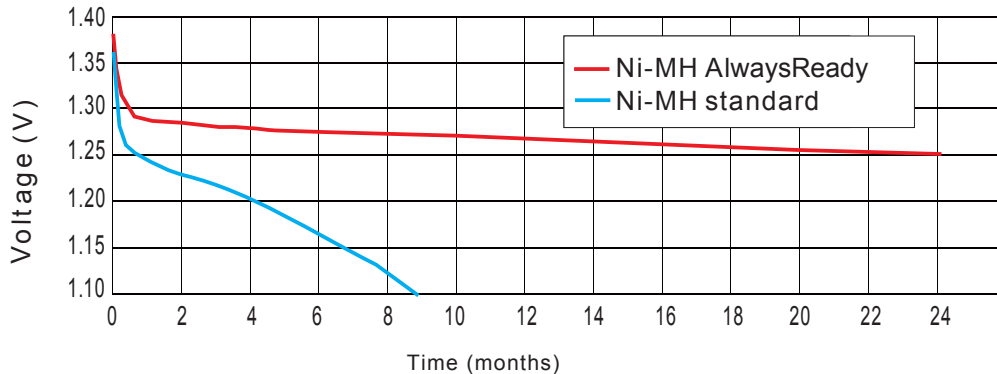

### Charge Characteristics

Measurement temperature:  $25 \pm 2^\circ\text{C}$

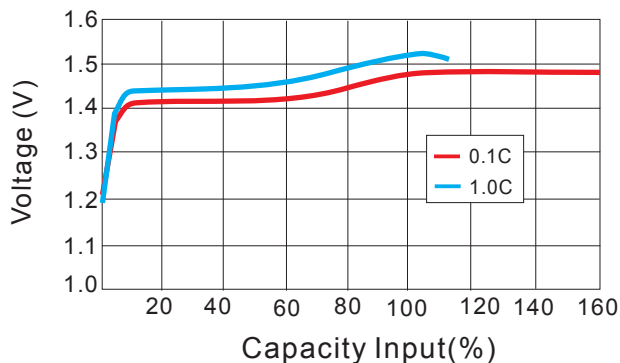

### Discharge Characteristics

Measurement temperature:  $25 \pm 2^\circ\text{C}$

Charge:  $0.1\text{C} \times 16\text{hrs}$

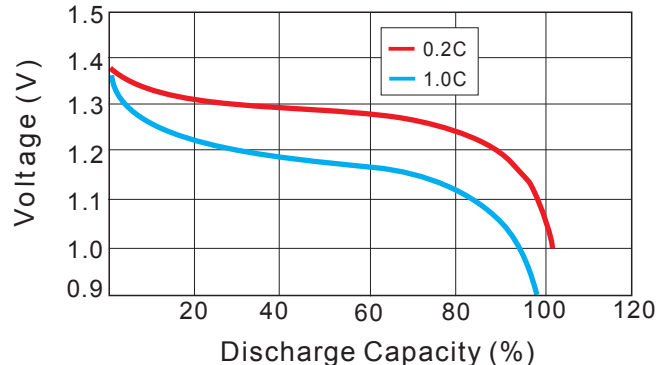

### IEC Cycle Life Curve

Measurement temperature:  $25 \pm 2^\circ\text{C}$

Procedure: According to IEC61951-2(2011)

7.5.1.2

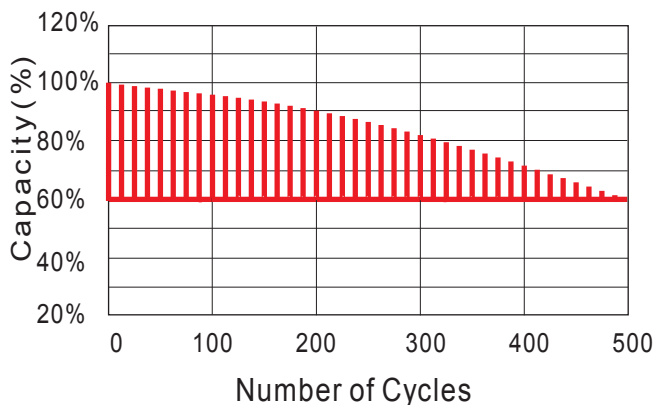

### Temperature Characteristics

Procedure: Charge 16hrs by 0.1C; Rest for 60mins

Discharge to 1.0V by 0.2C

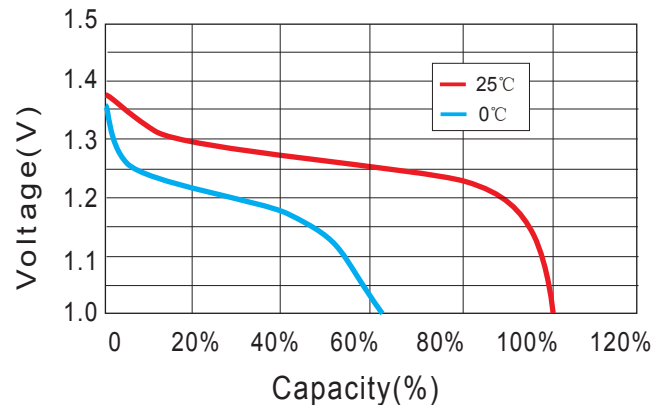

**Notice:**

Environmental elements comply with 2006/66/EC and US LAW 104-142 requirements. This data sheet is typical information specific to products manufactured at the time of its publication. For the latest information, contact us at: [info@camelionbattery.com](mailto:info@camelionbattery.com).