



12. Pullers

▶ Selection guide 520

▶ Workshop puller kits 523



Workshop panels 523
Case sets 524

▶ Outside pullers - 3 legs 525

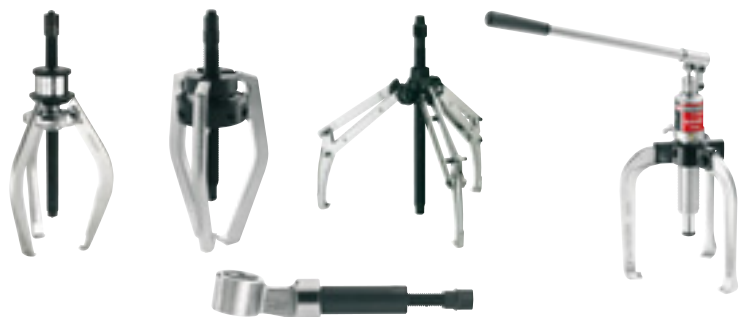

Reversible universal 3-leg puller..... 525
Slim 3-leg pullers 528
High capacity 3-leg pullers 529
Hydraulic 3-leg pullers 532
Jacks and pumps 537

▶ Outside pullers - 2 legs 539



Reversible universal 2-leg puller 539
Slim 2-leg pullers 541
Wide 2-leg pullers..... 542

▶ Inside pullers 545



Tip-type pullers, cage grip 545
Tip-type pullers, inside grip 546
Tip-type pullers, inside grip 547

▶ Slide hammers 549



▶ Separators and beam pullers 550



Puller kits..... 550
Separators 551
Beams..... 551
Beam puller accessories..... 552

▶ Stud extractors – nut splitters 553



Stud extractors..... 553
Stud drivers..... 554
Nut splitters 555



NEW

U232 self-gripping 2-leg puller

Strength and simplicity

Advantages

- ▶ Inside or outside grip
- ▶ Easy leg reversal
- ▶ Anti-rotation system



N ▶ 540

NEW

U301 Wide 2-leg puller range

Compact puller with "wrap-around" legs for improved grip

Advantages

- ▶ Self gripping and self centring
- ▶ One-handed installation
- ▶ Safety shear pins



N ▶ 542

Effortless 10 Tonne pulling force

Advantages

- ▶ Easy to operate: gradual, effortless transmission of power
- ▶ Added safety: high strength design and safety valve



N 532

















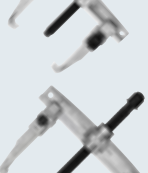

Selection guide

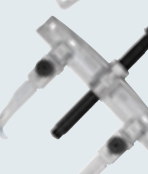
A choice of 90 pullers for all types of components up to 800 mm.

The right questions to ask when choosing a puller

- What type of component is to be removed? = bearing, pulley, studs or nuts.
- What is the diameter of the component to be removed? = choice of spread.
- How is the component to be gripped? = choice of type of grip : outside grip, inside grip, special grip.
- How is the component to be pulled? = choice of bearing point : on the central axis, on the outside of the component, no available bearing point (= need to use puller accessories).

■ Bearings
 ■ Pulleys
 ■ Studs
 ◀▶ Outside grip
 ▶◀ Inside grip

Spread ◀ mm ▶	Reach ▲ mm	Force T kN		Characteristics		
Outside grip - Adjustable 2 or 3 leg pullers						
◀7-140 ▶	▲147	3 30	U.306A-140	 System U.306 - 2 or 3 legs - Inside or outside grip - Self gripping - self centring	P.526	
◀10-180 ▶	▲200	4 40	U.306-180		P.526	
◀20-260 ▶	▲250	4 40	U.306-260		P.526	
◀15-170 ▶	▲170	10 100	U.310-170		P.527	
◀15-250 ▶	▲250	10 100	U.310-250		P.527	
Outside grip - 3 leg pullers						
◀6-80 ▶	▲90	1 10	U.302	 Compact series slim legs	P.528	
◀6-150 ▶	▲150	1,1 11	U.302-150		P.528	
◀6-200 ▶	▲200	1,7 17	U.302-200		P.528	
◀25-170 ▶	▲160	7 70	U.20	 Force	P.529	
◀25-260 ▶	▲220	7 70	U.20B		P.529	
◀30-800 ▶	▲720	- -	U.27AS3		P.530	
◀100-360 ▶	▲400	20 200	U.320		Heavy duty	P.531
◀100-530 ▶	▲550	30 300	U.330		P.531	
◀100-650 ▶	▲695	100 1000	U.60B	Very heavy duty	P.531	
◀45-270 ▶	▲260	10 100	U.312H	 Heavy duty hydraulic	P.532	
◀100-360 ▶	▲265	20 200	U.320H		P.536	
◀100-530 ▶	▲395	30 300	U.330H		P.536	
Inside or outside grip - 2 leg pullers						
◀20-80 ▶	▲85	2 20	U.32T2-8	 Lockable reversible 2-leg puller	P.539	
▶90-140 ◀						
◀20-120 ▶	▲85	2 20	U.32T2-12		P.539	
▶90-180 ◀						
◀20-160 ▶	▲140	6 60	U.32T6-16		P.539	
▶130-250 ◀						
◀20-200 ▶	▲140	6 60	U.32T6-20		P.539	
▶130-290 ◀						
◀25-250 ▶	▲170	15 150	U.32T15-25		P.539	
▶180-380 ◀						
◀25-360 ▶	▲170	15 150	U.32T15-35		P.539	
▶180-480 ◀						
◀25-500 ▶	▲270	15 150	U.32T15		P.539	
▶180-530 ◀						
◀25-65 ▶	▲65	1,5 15	U.232-65	 Reversible 2-leg puller	P.540	
▶55-90 ◀						
◀30-90 ▶	▲100	3 30	U.232-90		P.540	
▶75-110 ◀						
◀45-130 ▶	▲100	3 30	U.232-130		P.540	
▶75-160 ◀						
◀45-160 ▶	▲145	4 40	U.232-160		P.540	
▶120-200 ◀						
◀45-210 ▶	▲145	4 40	U.232-210		P.540	
▶120-250 ◀						
◀65-270 ▶	▲190	5 50	U.232-270		P.540	
▶140-340 ◀						
◀65-340 ▶	▲190	5 50	U.232-340		P.540	
▶140-390 ◀						

Spread ◀ mm ▶	Reach ▲ mm	Force			Characteristics	
		T	kN			
Outside grip - 2 leg pullers						
◀10-35 ▶	▲37	-	-	U.14A		Compact series slim legs P.541
◀10-45 ▶	▲58	-	-	U.14L		P.541
◀10-80 ▶	▲90	0,9	9	U.301		P.541
◀10-150 ▶	▲150	1	10	U.301-150		P.541
◀15-200 ▶	▲200	1,3	13	U.301-200		P.541
◀10-50 ▶	▲70	1	10	U.301P		Compact series wide legs P.542
◀10-100 ▶	▲100	1,1	11	U.301M		P.542
◀10-110 ▶	▲130	1,7	17	U.301L		P.542
◀10-55 ▶	▲75	1	10	U.35P		wide legs P.543
◀10-75 ▶	▲90	4	40	U.35		P.543
◀15-75 ▶	▲130	3	30	U.35L		P.543
◀40-180 ▶	▲245	7	70	U.34		P.543
◀10-85 ▶	▲120	1,5	15	U.42		Slim legs with yoke P.544
◀10-85 ▶	▲180	1,5	15	U.42B		P.544
◀10-150 ▶	▲130	6	60	U.52		P.544
◀130-156 ▶	▲80	-	-	DM.31		Special for grooved pulleys P.544
◀45-175 ▶	▲	-	-	DM.50		pitch = 3.56mm P.766
Special inside grip						
▶23-130 ◀	▲140	3	30	U.306A-130N		System U.306 P.526
▶50-170 ◀	▲190	4	40	U.306-170N		P.526
▶50-230 ◀	▲190	4	40	U.310-230N		P.528
Inside grip - Adaptable 2 or 3 leg pullers						
▶32-70 ◀	▲ -	-	-	U.51B		P.546
▶70-160 ◀	▲ -	-	-	U.28		P.546
▶6-60 ◀	▲ -	-	-	U.49P1 à U.49AD10		P.547
▶20-200 ◀	▲240	-	-	U.23D5 à U.23D32		P.545
Stud extractors						
◀3-50 ▶	▲ -	-	-	285		Flush broken studs, right-hand thread P.553
◀6-14 ▶	▲ -	-	-	885		Flush broken studs, right and left-hand thread P.554
◀5-20 ▶	▲ -	-	-	286A		Multi-diameter tool for removing/refitting or pulling studs P.554
◀15-27 ▶	▲ -	-	-	286PL		P.554
◀6-16 ▶	▲ -	-	-	287B		Single-diameter tool for removing/refitting or pulling studs P.555
Separators - Beams - Threaded adaptors						
◀5-250 ▶	▲ -	-	-	U.53T		Separators P.551
◀25-95 ▶	▲100	-	-	U.23K		Beams P.551
◀40-400 ▶	▲350	-	-	U.53K		P.551
Ø M4-M14	▲ -	-	-	U.53E		Threaded adaptors P.552

Slide hammers

Compatible pullers				
U.49P1 → U.49P4	M8	0,2	U.49L	P.549
U.49P5 → U.49P9	Tr1/2	1,0	U.49AM	P.549
U.49P5 → U.49P9 / U.49AD10 / U.35(L) / U.42(L) / U.32T2	M16	1,6	U.306M	P.549
U.20(B) / U.310(-230N) / U.32T6-16 / U.32T6-20	M22	5,2	U.2	P.549

Information

The quoted pulling powers are the actual powers obtained in the laboratory under normal working conditions. All our pullers are designed to provide maximum safety and reliability.

Safety

As soon as access allows, use a 3-leg rather than a 2-leg configuration. Check that the puller is properly aligned with the axis before applying the pulling force.





FACOM, YOUR PULLER SPECIALIST

FACOM : designer and manufacturer.

- A comprehensive range.



- Your safety : our priority.
 - The design, choice of materials and optimisation of Facom's pullers ensure guaranteed safety and reliability.
 - Facom has developed a "force limiting" safety system consisting of a shear pin that fails when the maximum allowable torque is reached (series U.306/310 and U.20)



Pullers : it pays to be ready.

- Saves time : having the right puller readily to hand allows a speedy response in the event of a breakdown, and a quick resumption of production.
- A sound investment : when a machine breaks down, each second of lost production represents a great deal of money. A puller often pays for itself after just one use.



Pullers : safety first



FACOM'S 10 TIPS :

Pulling components can involve very high forces.

The operation can therefore be very hazardous, which is why pullers require professional handling

- 1 Wear eye protection and gloves (see section 15).
- 2 Always ensure that a puller is in good condition and that the screw is evenly lubricated.
- 3 Never modify a puller Do not grind or weld the legs. Modifications can be very dangerous for the user and invalidates the guarantee.
- 4 Wherever possible, select a 3-leg puller for optimum load distribution.
- 5 Position the legs carefully, making sure that the puller is straight in relation to the line of traction.
- 6 Where possible, use a net (or sheet) to cover both the puller and the part being removed, in case the assembly springs apart suddenly.
- 7 Before applying pressure, check that the component is free to move, i.e. that all brackets, pins and nuts have been removed.
- 8 Never stand behind a puller - stay to one side.
- 9 Ask any bystanders to keep their distance.
- 10 Apply pressure to the puller screw progressively. Do not use impact wrenches.

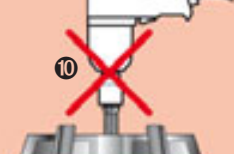
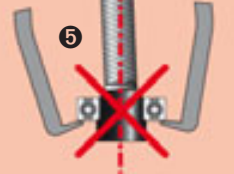
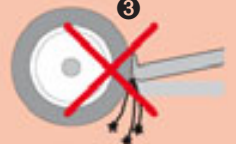
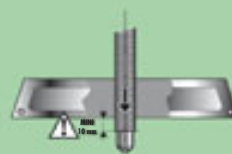
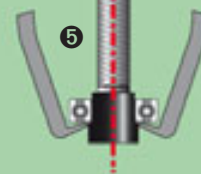

Workshop puller kits

▶ Workshop panels

Light-engineering kit

U.JA1

- Comprising :
 - 2 slim-leg outside grip pullers = U.301 and U.302 (Spread : 15 to 80 mm).
 - 4 inside expansion pullers = U.49P1 to U.49P4 (Spread : 6 to 18 mm).
 - + slide hammer U.49L.
 - 1 outside separator for difficult applications = U.53T1 (Spread : 5 to 60 mm) and beam U.53K1.
- Display panel PK.2.

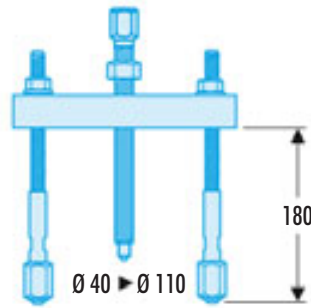

	Dimensions mm	ΔΔ kg
U.JA1	444 x 444	4,3

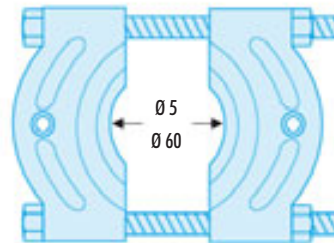

4-Tonne kit

U.J2

- Comprising :
 - 1 outside leg puller = U.306A140 (Spread : 7 to 140 mm).
 - 2 sets of 3 long legs for outside grip = U.306G10 (Spread : 10 to 180 mm) and U.306G15 (Spread : 20 to 260 mm).
 - 2 sets of 3 long legs for inside grip = U.306G2 (Spread : 23 to 130 mm) and U.306G20 (Spread : 60 to 170 mm).
 - 1 long screw with end cap U.306-3
 - 1 beam U.40 (attached using ring and nut U.306A1, supplied with the kit).
 - 1 slide hammer U.306M.
- Display panel PK.1.

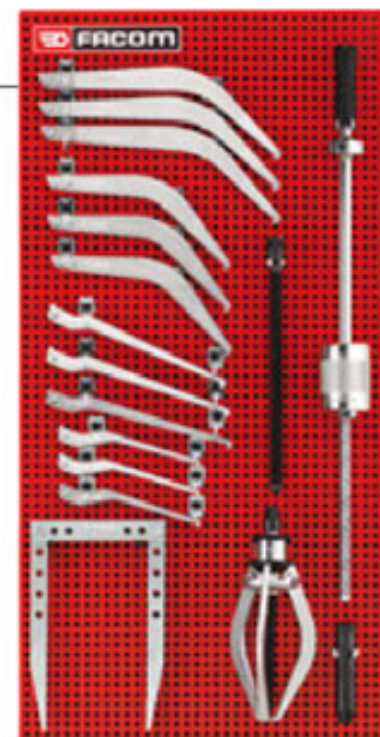
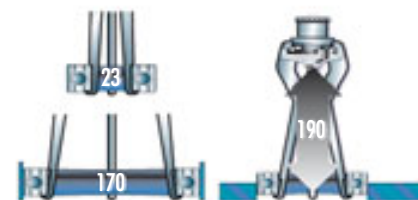
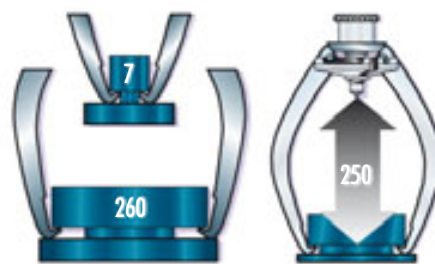

	Dimensions mm	ΔΔ kg
U.J2	444 x 888	12,4

General engineering kit

U.JA3

- Comprising :
 - 1 sliding-leg puller = U.32T6-20 outside grip (Spread : 20 to 200 mm) / inside grip (Spread : 130 to 290 mm).
 - 1 separator U.53T2 (Spread : 15 to 110 mm) and beam U.53K2.
 - 4 expansion pullers U.49P5 to U.49P8 (Spread : 18 to 50 mm).
 - 1 slide hammer U.306M with adaptor U.49BR1.
 - 30-tonne jack U.33A.
- Display panel PK.1.

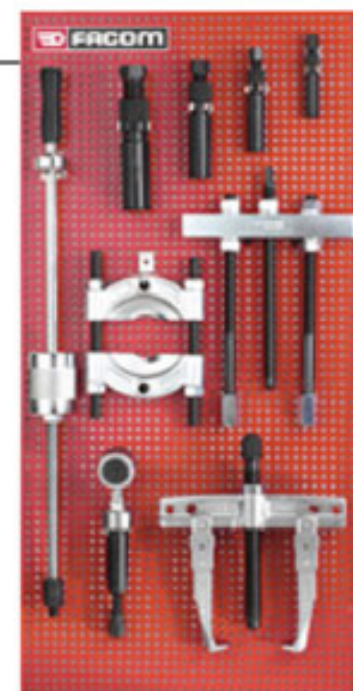
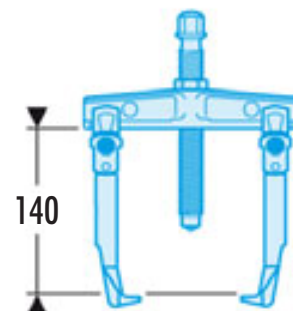

	Dimensions mm	ΔΔ kg
U.JA3	444 x 888	15,5

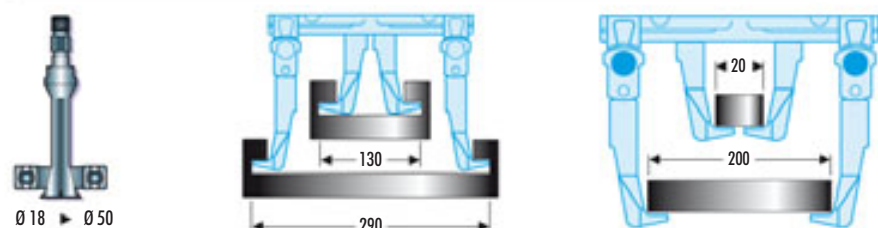

► Case sets

Light-engineering kit

U.301BJ1

- Comprising :
 - 1 outside puller U.301 (Spread : 10 to 80 mm).
 - 4 expansion pullers U.49P1 to U.49P4 (Spread : 6 to 18 mm).
 - 1 beam U.53 KLO.
- Supplied in a plastic case BP 112 and tray PL.182B.

	Dimensions mm	$\Delta\Delta$ kg
U.301BJ1	390 x 170 x 170	2,1



General engineering kit

U.102T

- Comprising :
 - U.32T2-8 : 2-tonne sliding-leg puller and set of long legs; reach P1 : 85 mm, P2 : 185 mm
 - U.32T6-20 : 6-tonne sliding-leg puller and set of long legs; reach P1 : 140 mm, P2 : 280 mm
 - U.53T2 : separator (Spread : 15 to 110 mm).
 - U.33A : 30-tonne jack.
- Supplied in a steel case BT.108 with tray PL.287 and PL.288.

	Dimensions mm	$\Delta\Delta$ kg
U.102T	450 x 270 x 110	14,5

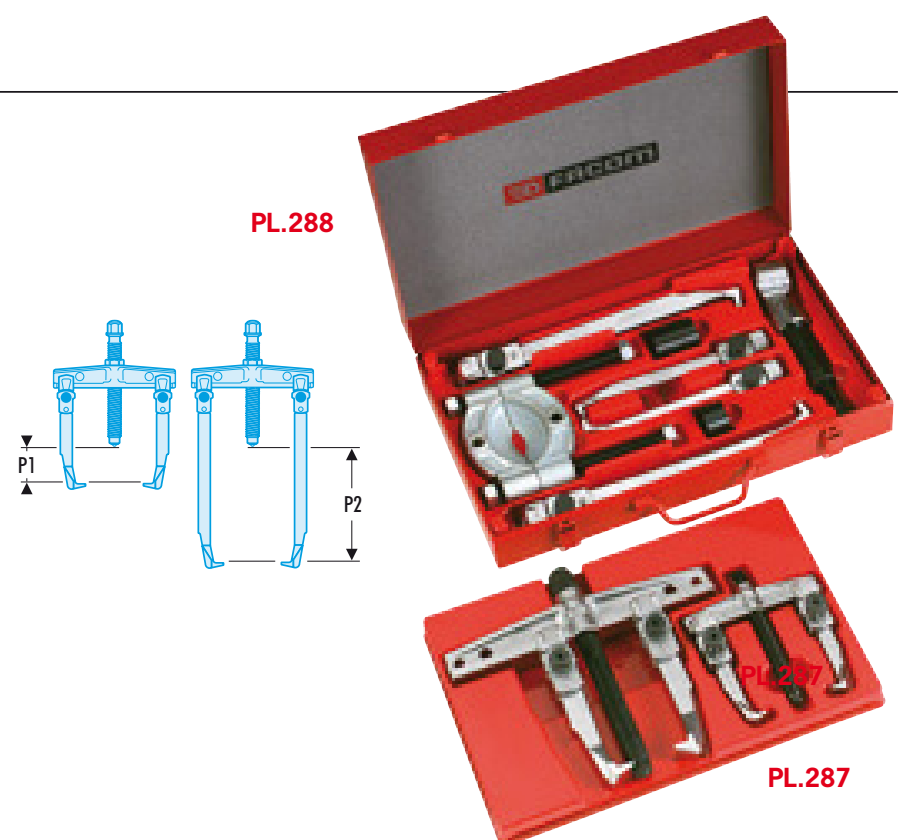
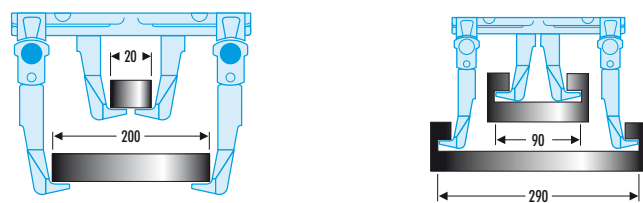

General engineering kit

U.103A

- A complete set offering normal pulling power for all general engineering applications.
- Comprising :
 - U.35L (Spread : 15 to 75 mm) and U.34 (Spread : 40 to 80 mm) : wide-leg outside pullers.
 - U.51B : bearing inside puller (Spread : 32 to 70 mm).
 - U.40 : beam.
 - U.33A : 30-tonne jack.
- Supplied in a steel case BT.108 with tray PL.195A.

	Dimensions mm	$\Delta\Delta$ kg
U.103A	452 x 286 x 111	13,3

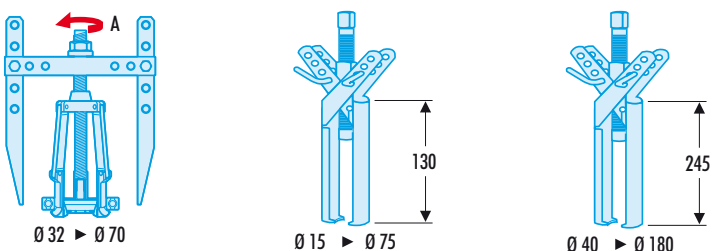

Outside pullers - 3 legs

► Reversible universal 3-leg puller

U.306/310

Covers 80 %
of common applications

**Exclusive Facom
body.**
Easier, safer..



Safe

Locknut

- Tightening the locknut securely locks the legs in place.

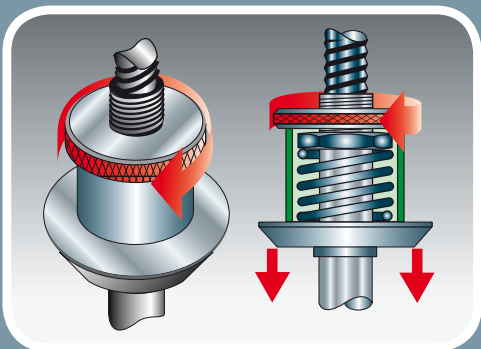

Shear pin

- The pin shears if torque limit is exceeded.

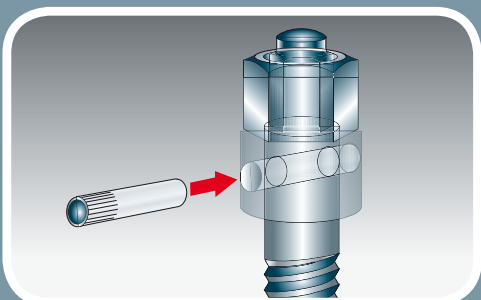

PRACTICAL, EFFICIENT, VERSATILE

Versatile

- Based on a single body, the U.306/U.310 system can be configured to perform all routine mechanical engineering pulling operations
- Puller accessories provide a full range of pulling solutions.

Inside or outside configuration 2 or 3-leg pullers, with or without accessories.

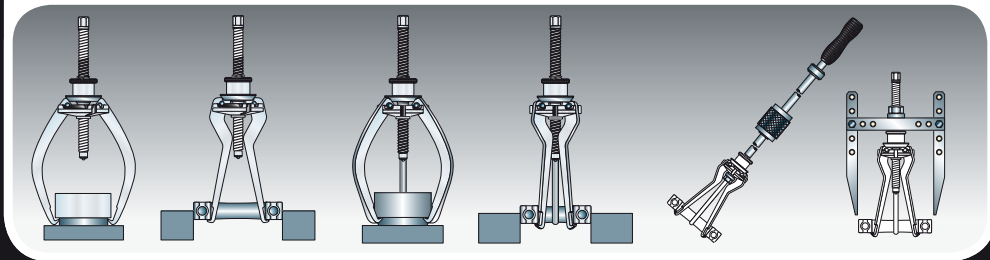

Easy to use

- Self-gripping.
- Self-centring.

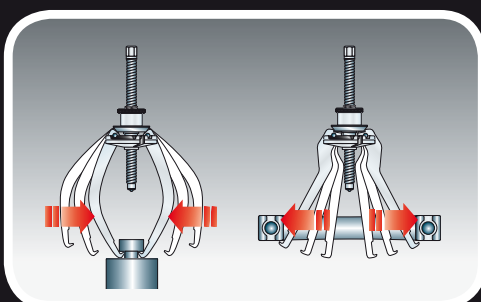

Easy leg change

- Compress the spring.
- Remove the leg in place and place the desired new leg.

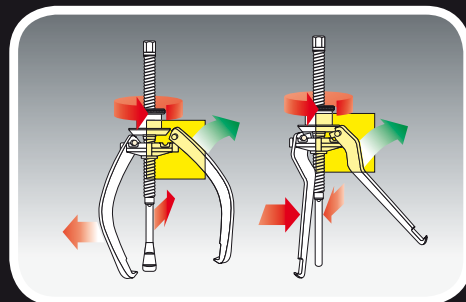

U.306 outside pullers

• Puller accessories = Slide hammer U.306M (direct attachment) and beam U.40 (attached using ring and nut U.306A1 to be ordered separately).

☞	C mini - maxi mm	P maxi mm	T Tonnes	T kN	Legs	Screw	● mm	ΔΔ kg
U.306A140	7 - 140	147	3	30	U.306G1	U.306-4	18	1,6
U.306-180	10 - 180	200	4	40	U.306G10	U.306-2	18	3,0
U.306-260	20 - 260	250	4	40	U.306G15	U.306-3 + U.306-3-03	18	3,9

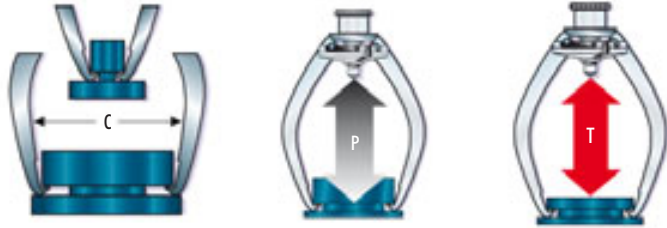

U.306N Inside pullers

• Puller accessories = Slide hammer U.306M (direct attachment) and beam U.40 (attached using ring and nut U.306A1 to be ordered separately).

☞	C mini - maxi mm	P maxi mm	T Tonnes	T kN	Legs	Screw	● mm	ΔΔ kg
U.306A130N	23 - 130	140	3	30	U.306G2	U.306-4	18	1,3
U.306-170N	50 - 170	190	4	40	U.306G20	U.306-2	18	2,5

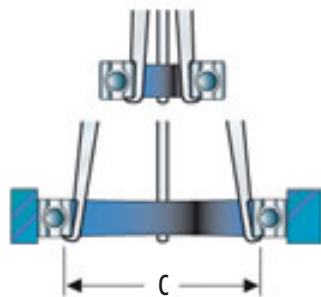

Spare legs for puller U.306

• For your safety, we recommend that all the legs are replaced in the event of a problem.
• Legs supplied individually.

☞	L mm	a mm	b mm	c mm	d mm	Puller	ΔΔ kg
U.306G1	185	4,5	14	4	13	U.306A140	0,210
U.306G10	250	5	14	4	13	U.306-180	0,320
U.306G15	310	6,5	14	4	13	U.306-260	0,450
U.306G2	170	4,5	8	3,5	9,5	U.306A130N	0,180
U.306G20	230	6,5	8	4	12	U.306-170N	0,210

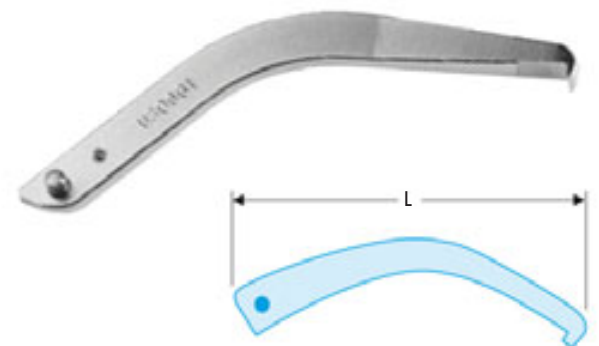
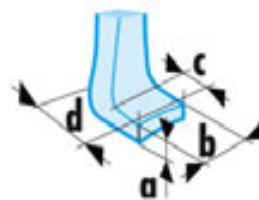

Spare screws for puller U.306

• Screw supplied individually.

☞	Ø mm	L mm	● mm	Puller	ΔΔ kg
U.306-2	M16	310	18	U.306-180 / U.306-170N	0,410
U.306-3	M16	370	18	U.306-260	0,730
U.306-4	M16	250	18	U.306A140 / U.306A130N	0,340

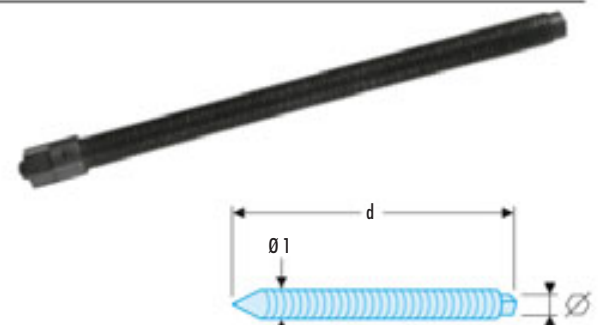

Inside puller

U.310-230N

- Puller fitted with 3 long legs.
- Puller accessories (supplied separately) : hydraulic screw U.3 and slide hammer U.2.
- Dimensions : 360 x 180 mm.
- ΔΔ : 4 kg.

	C mini - maxi mm	P maxi mm	T Tonnes	T kN	Legs	mm	Screw	ΔΔ kg
U.310-230N	50 - 230	200	10	100	U.310G3	24	U.20B1	4

U.310-170 - U.310-250 - U.310-230N

	1
U.310-170	U.20B1
U.310-250	U.310-250-10
U.310-230N	U.20B1



Spare legs for puller U.310

- For your safety, we recommend that all the legs are replaced in the event of a problem.
- Leg supplied individually.

	L mm	a mm	b mm	c mm	d mm	Puller	ΔΔ kg
U.310G1	230	6	26	5	19	U.310-170	0,600
U.310G2	310	7	26	5,5	19	U.310-250	0,840
U.310G3	260	10	12	5,5	15	U.310-230N	0,400



Spare screws for puller U.310

- Screws supplied singly.

	Ø mm	L mm	mm	Puller	ΔΔ kg
U.20B1	M22	355	24	U.310-170 / U.310-230N	0,960
U.310-250-10	M22	355	24	U.310-250	1,100

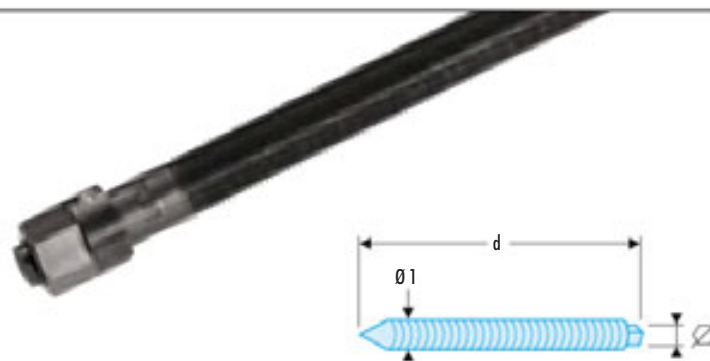

Slim 3-leg pullers

U.302 Self-gripping slim 3-leg pullers

- Range of pullers with spreads of 80, 150 and 200 mm.
 - Puller accessories (supplied separately): slide hammer U.49AM.
- Using adaptor U.301E1 (U.302 and U.302-150).
Using adaptor U.301E2 (U.302-200).

	C mini - maxi mm	P maxi mm	T Tonnes	T kN	Legs	Screw	mm	ΔΔ kg
U.302	17 - 80	90	1,5	15	U.301G	U.301-04	10	0,64
U.302-150	25 - 150	150	1,5	15	U.301-G150	U.301-04-150	10	1,02
U.302-200	25 - 200	200	2,4	24	U.301G-200	U.301-04-200	13	1,74



Outside pullers - 3 legs

Spare legs for puller U.302

- For your safety, we recommend that all the legs are replaced in the event of a problem.
- Legs supplied individually.

	L mm	a mm	b mm	c mm	d mm	Puller	$\Delta\Delta$ kg
U.301G	130	5	8	7	16	U.302	0.60
U.301G -150	205	6	8	7	17	U.302-150	0.84
U.301G - 200	270	6	8	7	18	U.302-200	0.40



► High capacity 3-leg pullers

Short-reach outside puller

U.20

- Shear pin prevents torque exceeding allowable limit.
- Supplied with 2 spare shear pins.
- Fitted with anti-rotation ring U.20-12.
- Puller accessories (supplied separately) : slide hammer U.2 and hydraulic screw U.3.

	C mini - maxi mm	P maxi mm	T Tonnes	T kN	Legs	Screw	Φ mm	$\Delta\Delta$ kg
U.20	25-170	160	7	70	U.20SE4	U.20-1S	24	3,2

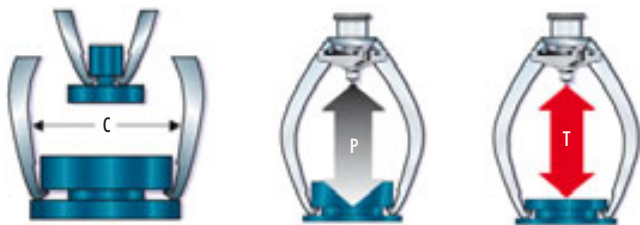

Long-reach outside puller

U.20B

- Shear pin prevents torque exceeding allowable limit.
- Supplied with 2 spare shear pins.
- Fitted with anti-rotation ring U.20-12.
- Puller accessories (supplied separately) : slide hammer U.2 and hydraulic screw U.3.

	C mini - maxi mm	P maxi mm	T Tonnes	T kN	Legs	Screw	Φ mm	$\Delta\Delta$ kg
U.20B	25-260	220	7	70	U.20BSE4	U.20B1S	24	3,9

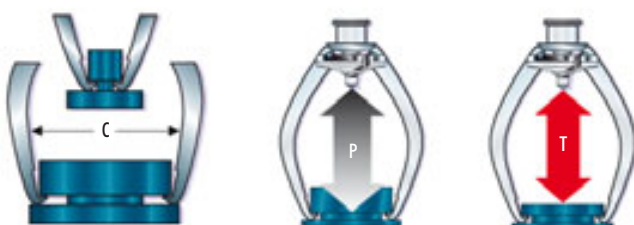

High-capacity outside puller

U.27AS3

- Can be fitted with long legs U.27D3 and linkage system U.27B3.

☞	C mini - maxi mm	P mm	Ø mm	Screw	ΔΔ kg
U.27AS3	30-460	360	35	U.27-6	12,4

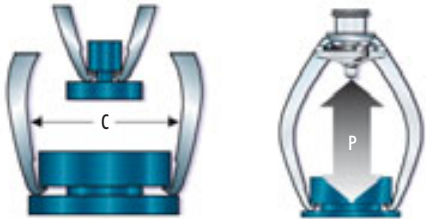

Set of 3 long legs for U.27AS3

U.27D3

- 3 long reach legs designed to fit puller U.27AS3.

☞	C mini - maxi mm	P mm	ΔΔ kg
U.27D3	40-460	480	4,6

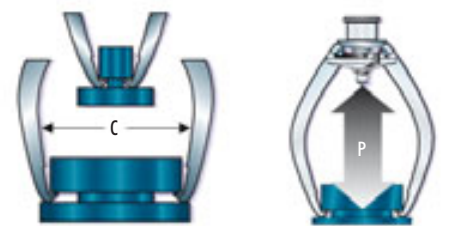

Set of 3 long links for U.27AS3

U.27B3

- Long links designed to increase spread of puller U.27AS3 from 460 to 800 mm.

☞	C mini - maxi mm	P mm	ΔΔ kg
U.27B3	50-800	600	20

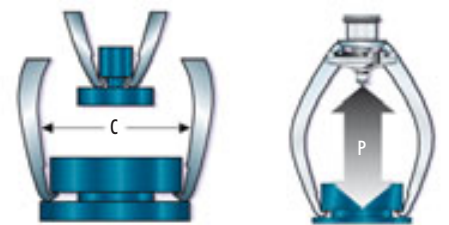

U.27AS3 - Attachment options

LONG LEGS AND LINKS FOR INCREASED VERSATILITY

U.27AS3

Fitted with long legs.



Fitted with long links.
U.27D3



Fitted with standard legs and links.
U.27B3
- Spread : 30 to 460 mm.
- Max. reach : 360 mm.



Fitted with long legs and links.
U.27D3 + U.27B3

Outside pullers - 3 legs

High-capacity outside puller

U.320

- Force : 20 tonnes; 200 kN.
- Fitted with 3 outside-gripping legs.
- Supplied complete with screw extension : U.320-14.
- Dimensions : 700 x 250 x 250 mm.

	C mini - maxi mm	P maxi mm	T Tonnes	T kN	Legs	Screw	mm	ΔΔ kg
U.320	100-360	400	20	200	U.320-13A	U.320-01	36	20

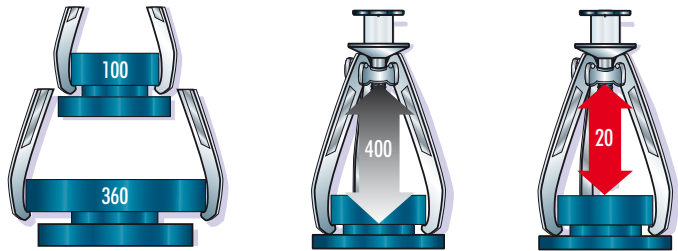

High-capacity outside puller

U.330

- Force : 30 tonnes; 300 kN.
- Fitted with 3 outside-gripping legs.
- Supplied complete with screw extension : U.330-14.
- Dimensions : 900 x 300 x 300 mm.

	C mini - maxi mm	P maxi mm	T Tonnes	T kN	Legs	Screw	mm	ΔΔ kg
U.330	100-530	550	30	300	U.330-08	U.330-02	41	39

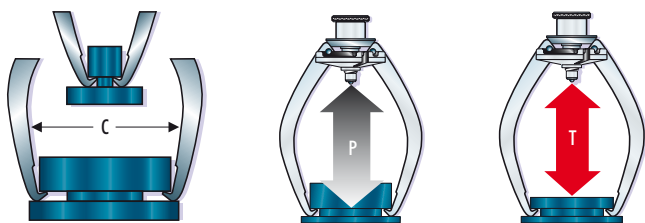

High-capacity outside puller

U.60B

- Force : 100 tonnes; 100 kN.
- 4 legs for very high forces.
- Fitted with a screw Ø 50 x 400 mm hardened to 100 kg/mm².

	C mini - maxi mm	P maxi mm	T Tonnes	T kN	ΔΔ kg
U.60B	100-650	695	100	1000	66

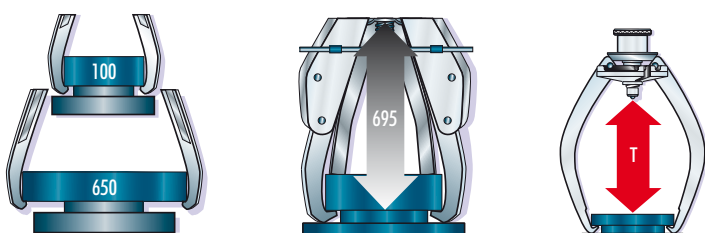

► Hydraulic 3-leg pullers

New

U.312H
Medium-duty hydraulic puller



10 TONNES OF EFFORTLESS PULLING FORCE READILY TO HAND

Versatile

- Based on a single body that can be fitted with 4 different sizes of legs for bearings Ø 45 to 270 mm.
- 2 or 3-leg configurations.
- For light to heavy engineering applications.

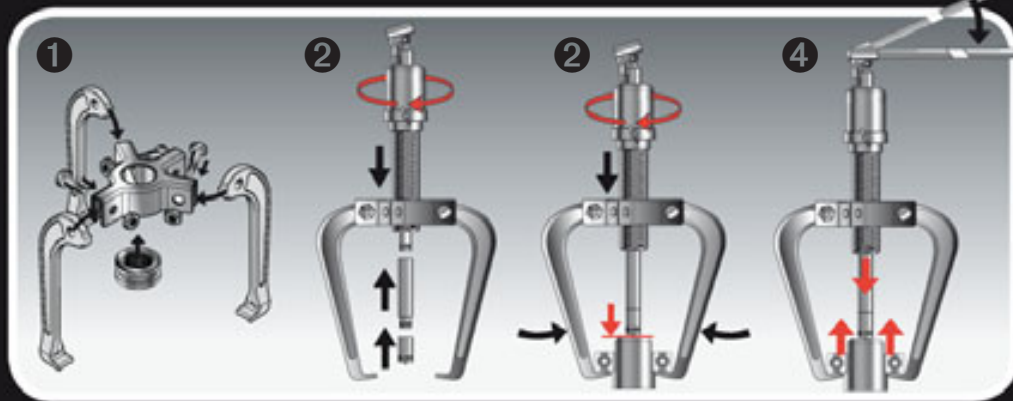

- 1/ Assemble the body and the correct legs for the bearing.
- 2/ Position the jack and the puller.
- 3/ Pump the jack. The bearing will be removed safely and effortlessly.

Practical

The carry case (field servicing) dismantles for easy storage in the drawers of your FACOM JET XL roller cabinets (workshop servicing).



Safety first

- A safety valve hydraulically limits the jack to 10 tonnes.
- The other mechanical components can withstand much higher forces.



Outside pullers - 3 legs

10T hydraulic puller set with 4 sets of legs

U.312HJ4

- Comprising :
 - 10 tonne (100 kN) hydraulic jack U.312-01 + guide U.312-02 + set of 2 extensions U.312-03.
 - A 2 or 3-leg puller body U.312-04 + centring screw U.312-04-01 + set of 3 screws/nuts U.312-04-02.
 - 3 outside-gripping legs U.312G110 : Spread : 45 to 85 mm; Max. reach : 110 mm.
 - 3 outside-gripping legs U.312G160 : Spread : 80 to 170 mm; Max. reach : 160 mm.
 - 3 outside-gripping legs U.312G210, Spread : 90 to 210 mm; Max. reach : 210 mm.
 - 3 outside-gripping legs U.312G260, Spread : 110 to 270 mm; Max. reach : 260 mm.
- Supplied in a plastic case U.312VAL 565 x 412 x 105 mm.
- ΔΔ : 14.4 kg.



10T hydraulic puller set with 3 sets of legs

U.312HJ3

- Comprising :
 - 10 tonne (100 kN) hydraulic jack U.312-01 + guide U.312-02 + set of 2 extensions U.312-03.
 - A 2 or 3-leg puller body U.312-04 + centring screw U.312-04-01 + set of 3 screws/nuts U.312-04-02.
 - 3 outside-gripping legs U.312G160 : Spread : 80 to 170 mm; Max. reach : 160 mm.
 - 3 outside-gripping legs U.312G210, Spread : 90 to 210 mm; Max. reach : 210 mm.
 - 3 outside-gripping legs U.312G260, Spread : 110 to 270 mm; Max. reach : 260 mm.
- Supplied in a plastic case U.312VAL, dimension : 565 x 412 x 105 mm.
- ΔΔ : 13.2 kg.



10 T hydraulic jack for U.312H**U.312-01**

- Hydraulic jack : 10 tonnes; 100 kN pulling force.
- Rod stroke : 80 mm.
- ΔΔ : 2.28 kg.

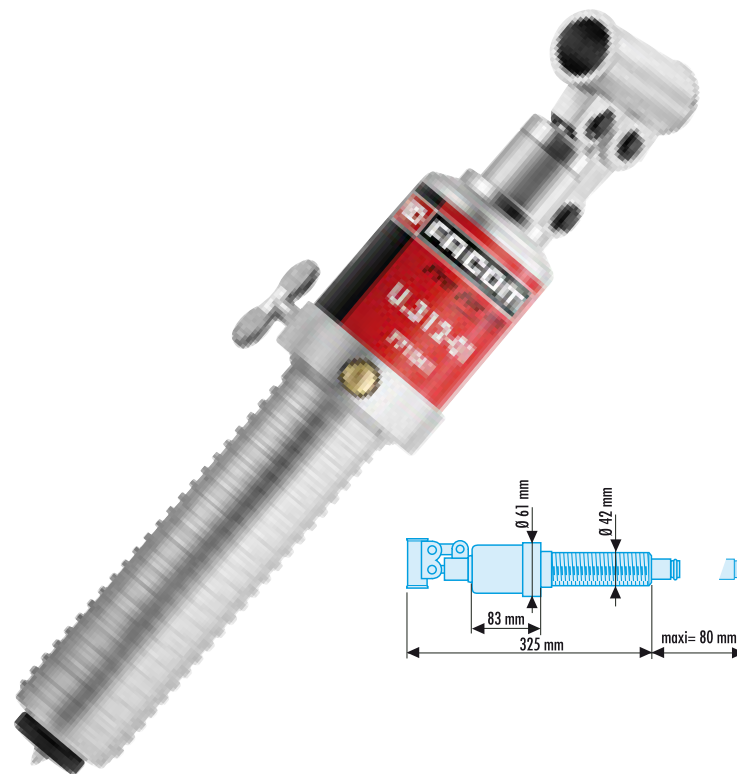
**Guide tip for U.312H****U.312-02**

- For jack U.312-01.
- ΔΔ : 0.08 kg.

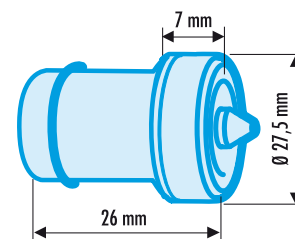
**Set of 2 extensions for U.312H****U.312-03**

- For jack U.312-01.
- ΔΔ : 0.420 kg.

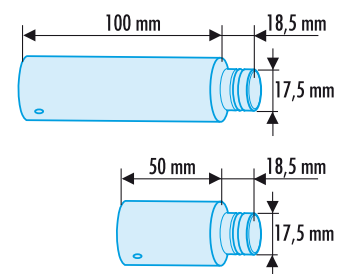
**2 or 3-leg body for U.312H****U.312-04**

- This body allows 2 or 3 legs to be mounted using centring nut U.312-04-01 and the set of 3 bolts and nuts U.312-01-02.
- ΔΔ : 0.44 kg.

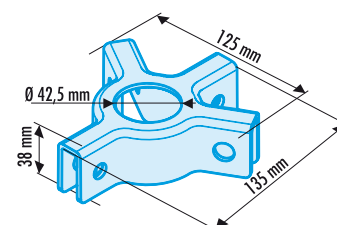

Outside pullers - 3 legs

Centring nut for U.312H

U.312-04-01

- This centring nut allows 2 or 3 legs to be mounted using the body U.312-04-04 and the set of 3 bolts and nuts U.312-01-02.

$\Delta\Delta$: 0.26 kg.

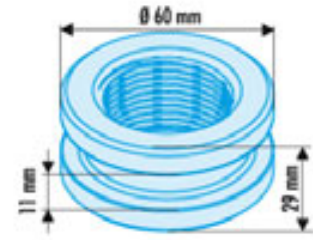

Set of 3 bolts and 3 nuts for U.312H

U.312-04-02

- Spare set of 3 bolts and 2 nuts for puller U.312H

$\Delta\Delta$: 0.2 kg.

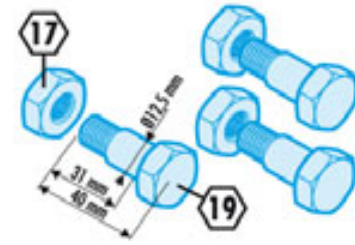

Spare legs for puller U.312H

- For your safety, we recommend that all the legs are replaced in the event of a problem.
- Legs supplied individually.

	C mini - maxi mm	P maxi mm	T Tonnes	T kN	L mm	a mm	b mm	c mm	d mm	$\Delta\Delta$ kg
U.312G110	45 - 85	110	10	100	150	7	25	15	33	0,4
U.312G160	80 - 170	160	10	100	200	7	25	15	36	0,54
U.312G210	90 - 210	210	10	100	245	7	25	15	36	0,72
U.312G260	110 - 270	260	10	100	295	7	25	15	38	0,98



U.312H				
	1	2	3	4
U.312H	U 312 01	U 312 04	U 312 04 01	U 312 04 02
	5	5	5	5
U.312H	U 312G110	U 312G160	U 312G210	U 312G260

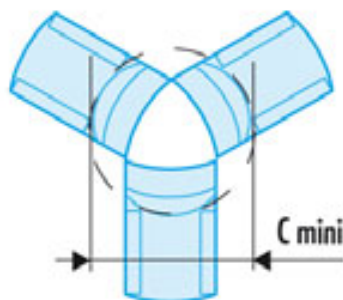
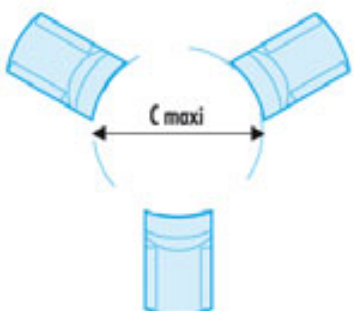



U.320H/U.330H - Heavy-duty Hydraulic pullers

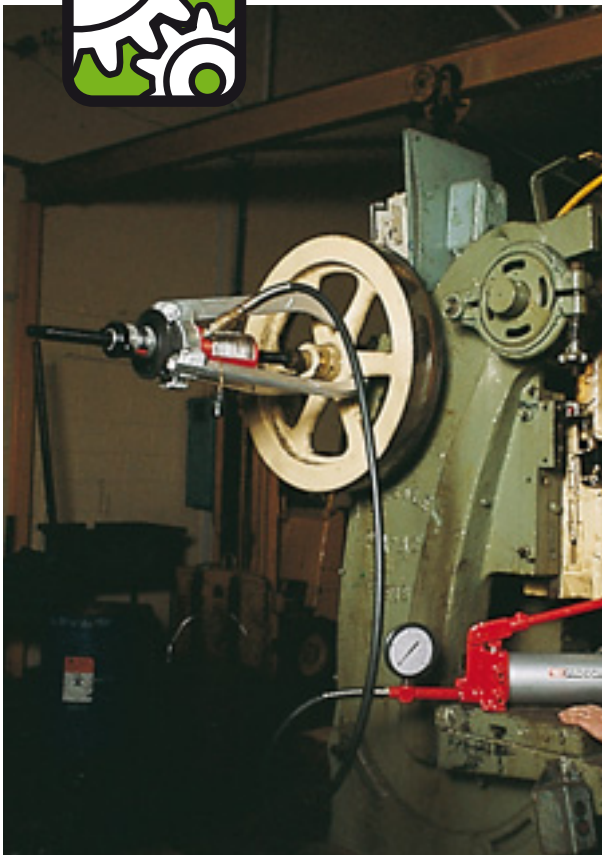

UP TO 30 TONNES IN COMPLETE SAFETY

Hydraulic models incorporate a hydraulic jack fitted with a standard male coupling. The jack is designed for pressures up to 700 bar and is supplied from a manual or powered pump. Details of these accessories can be found under "Pumps and jacks".

Powerful

- Fluid power ensures effortless and fast removal, while the puller remains steady even when applied to rotating components. Hydraulic models are used only with 3 legs.

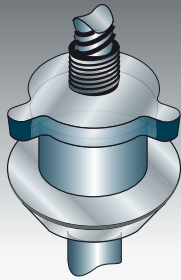

Safe

Legs are secured with a locknut.

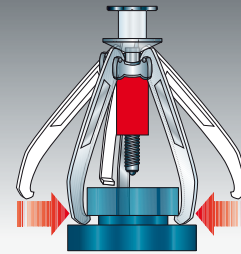

Automatic

Self-centring. Self-gripping.

20 T Hydraulic outside puller

U.320H

- Force : 20 tonnes; 200 kN.
- Fitted with 3 outside-gripping legs.
- 1 hollow jack UWG.320 with screw UWG.320H01.
- For use with 700 bar pump UWP.10M.
- Dimensions : 700 x 250 x 250 mm.
- △ 3-leg configuration only when used with hydraulic jack.

☞	C mini - maxi mm	P maxi mm	T Tonnes	T kN	Legs	Jack	Screw	● mm	△△ kg
U.320H	100-360	265	20	200	U.320-13A	UWG.320	UWG.320H01	21	23

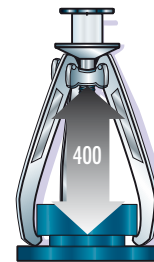
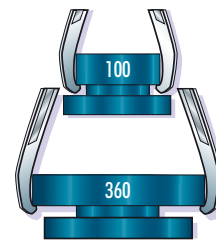

30 T hydraulic outside puller

U.330H

- Force : 30 tonnes; 300 kN.
- Fitted with 3 outside-gripping legs.
- 1 hollow jack UWG.330 with screw UWG.330H01.
- For use with 700 bar pump UWP.10M.
- Dimensions : 900 x 300 x 300 mm.
- △ 3-leg configuration only when used with hydraulic jack.

☞	C mini - maxi mm	P maxi mm	T Tonnes	T kN	Legs	Jack	Screw	● mm	△△ kg
U.330H	100-530	395	30	300	U.330-08	UWG.330	UWG.300H01	21	45

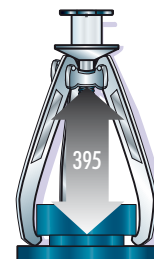
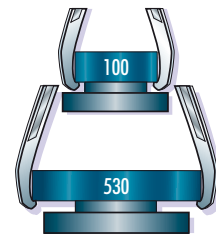

Outside pullers - 3 legs

► Jacks and pumps

UWG Hollow jacks

- For use with pullers U.320H and U.330H.
- Plunger with tapped through-hole to take a centre screw for pressure or pulling applications.
- Actuated by 700 bar pump UWP.10M.
- Caps clip into plunger, allowing use as lifting jack.

	Force kN	Travel mm	Ø A mm	Ø D mm	H mm	Oil capacity cm ³	ΔΔ kg
UWG.320	200	50	100	23,8	160	141,5	6,26
UWG.330	300	60	115	29,0	177	257,4	9,5

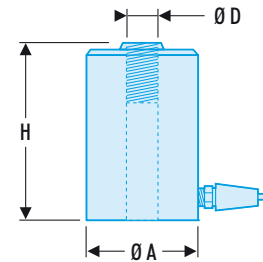

Screws for UWG jack

	mm	Length mm	Ø mm	Jacks	ΔΔ kg
UWG.320H01	21	590	27 x 300	UWG.320	2,3
UWG.330H01	25	780	33 x 350	UWG.330	4,5



Hydraulic screw

U.3

- Force : 10 tonnes; 100 kN.
- Thread length : 300 mm.
- Plunger travel : 14 mm.
- Thread : Ø 22 x 200 compatible with Facom pullers U.20, U.20B, U.310, U.28, U.32T6-16, U.32T6-20.
- ΔΔ : 4.53 kg.

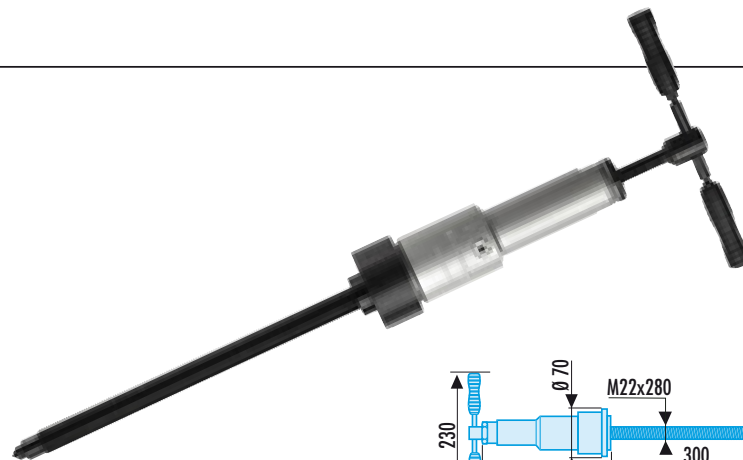

2-speed hand pump

UWP.10M

- Manual pump with pressure gauge and relief valve, giving 2 flow rates :
 - 1st stage : high flow, max. pressure 50 bar.
 - 2nd stage : low flow, max. pressure 700 bar.
- For use with pullers U.320H, U.330H and hollow jacks UWG.320, UWG.330.
- Oil capacity : 1,500 to 2,500 cm³.
- Complete with 1.80m hose fitted with female quick coupler WA.1166F.
- Dimensions : 450 x 170 x 160 mm.
- ΔΔ : 12.5 kg.

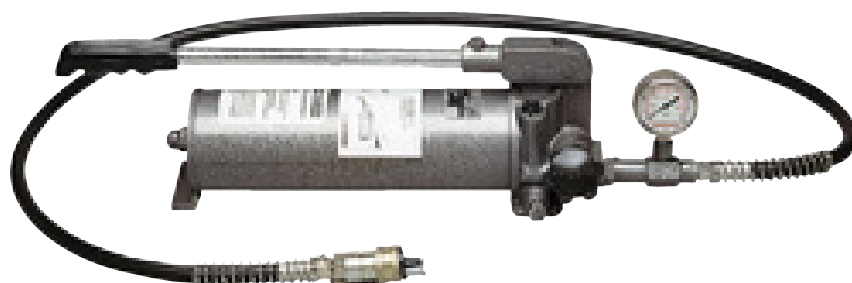

	Description
WA.21	Hydraulic oil - 2 litres





U.33A/U.66A - Hydraulic jacks



HYDRAULICALLY-ASSISTED PULLING ACTION

Used in conjunction with mechanical pullers, hydraulic jacks help separate the fittings to be removed



- Place the jack between the component and the puller's screw.
- Centre the loads.
- Apply pressure axially.



- Hold the puller while tightening the screw to allow the plunger to extend.
- The bearing is removed

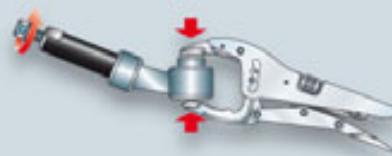

Plunger retraction

- Back off screw to release pressure.
- Use pliers or clamp to push back plunger.



Safety first

- During screw tightening, a safety pin will shear if the maximum allowable torque is exceeded.
- When using both puller and jack, make sure generated forces are compatible.
- Never use pneumatic tools.

30 tonne jack with mechanical screw

U.33A

- Travel 5 mm.
- Shear-pin rating 110 Nm.
- Supplied with 2 shims 25 and 50 mm.
- Ø 33 mm plunger
- Length : 260 mm, head height : 35 mm.
- Force : 30 tonnes; 300 kN.
- 19 mm hexagonal screw.
- ΔΔ : 1.9 kg.



120 tonne jack with mechanical screw

U.66A

- Travel : 15 mm.
- Shear-pin rating 550 Nm.
- Ø 80 mm plunger; Ø 47 mm bore.
- Head height : 105 mm. Length : 500 mm.*
- Force = 120 tonnes.
- ... mm hexagonal screw.
- ΔΔ : 8.75 kg.



Outside pullers - 2 legs

► Reversible universal 2-leg pullers

U.32T

Lockable 2-leg puller



HIGH PERFORMANCE PULLER

For inside and outside puller applications

2-leg puller, inside or outside grip

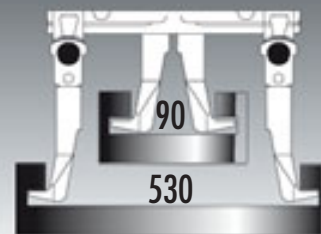
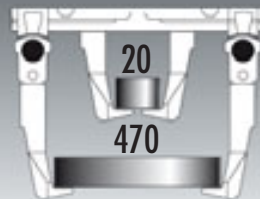

Inside and outside puller spread in millimetres.

Safety first



Pins

- Leg-mounting pins ensure easy and safe fixing to beam.
- Pins are treated to withstand pulling stresses.

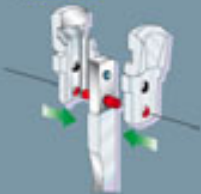

Leg retainer

- Beam end-stop prevents legs sliding off.



Knurled locknut

- Leg assembly locks in any position by hand-tightening the knurled locknut.

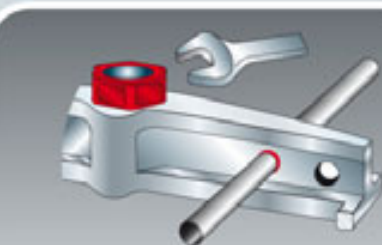

Rotation prevention

- Tightening the lock-nut with a wrench.
- Passing a rod through holes in the beam.

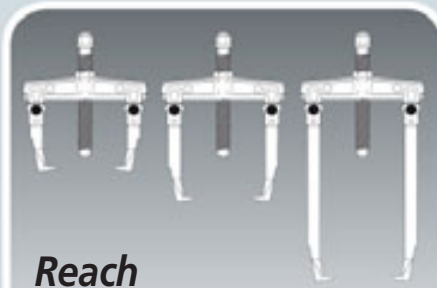

Reach

Long-leg sets are easily fitted to the beam using a unique system of attachment. They increase the reach up to 470 mm.

U.32T Lockable 2-leg sliding-leg puller

	C1 mm mini-maxi	C2 mm mini-maxi	P maxi mm	T Tonnes	T kN	Screw	● mm	ΔΔ kg
U.32T2-8	20 - 80	90 - 140	85	2	20	U.32T2-1	13	1,1
U.32T2-12	20 - 120	90 - 180	85	2	20	U.32T2-1	13	1,15
U.32T6-16	20 - 160	130 - 250	140	6	60	U.32T6-1	24	3,3
U.32T6-20	20 - 200	130 - 290	140	6	60	U.32T6-1	24	3,5
U.32T15-25	25 - 250	180 - 380	170	15	150	U.32T15-1	35	9,8
U.32T15-35	25 - 350	180 - 480	270	15	150	U.32T15-1	35	13,0
U.32T15-50	25 - 500	180 - 530	270	15	150	U.32T15-1	35	15,0

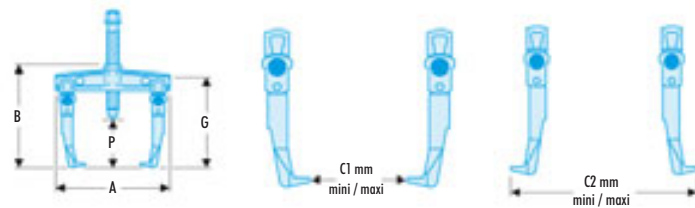

U.32TGA Spare legs for U.32T

- For your safety, we recommend that all the legs are replaced in the event of a problem.
- Legs supplied individually without mounting pins.

	Series U32T2	Series U32T6	Series U32T15	P mm	L mm	a mm	b mm	c mm	d mm	ΔΔ kg
U.32T2GA10	•			110	130	8,5	18,0	10	18	0,6
U.32T2GA20	•			185	225	2,5	18	10	18	0,8
U.32T2GA25	•			235	275	2,5	18	10	18	0,9
U.32T6GA15		•		150	180	4	24	15	28,5	1,4
U.32T6GA30		•		280	335	4	24	15	28,5	2,0
U.32T15GA20			•	170	250	5	34	20	36	3,4
U.32T15GA30			•	270	315	4	24	15	28,5	4,2
U.32T15GA40			•	370	445	5	34	20	36	5,0
U.32T15GA50			•	470	545	5	34	20	36	5,8

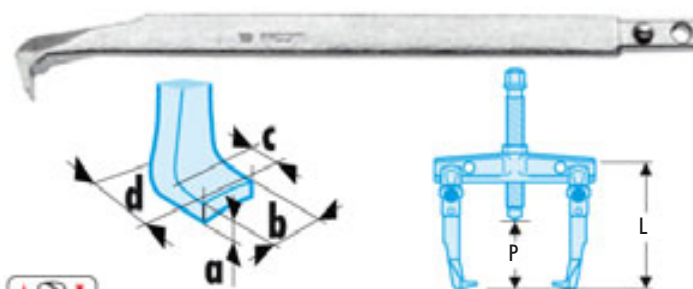

U.32T2 8 U.32T2 12 U.32T6 16 U.32T6 20
U.32T15 25 U.32T15 35 U.32T15 50

	1	2
U.32T2 8/ 12	U.32T2 1	U.32T2DG
U.32T6 16/ 20	U.32T6 1	U.32T6DG
U.32T15 25/ 35/ 50	U.32T15 1	U.32T15DG



New

U.232 - 2-leg puller

Strength and simplicity

2-leg puller, inside or outside grip

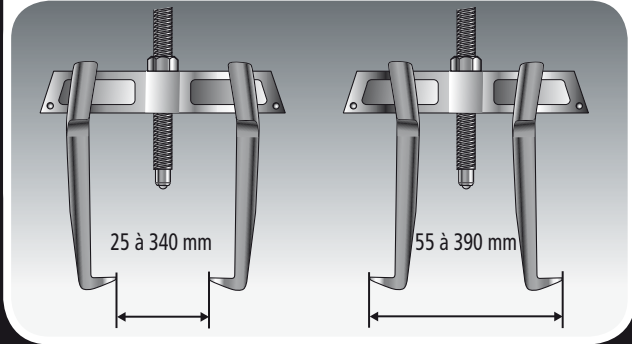

Anti-rotation system

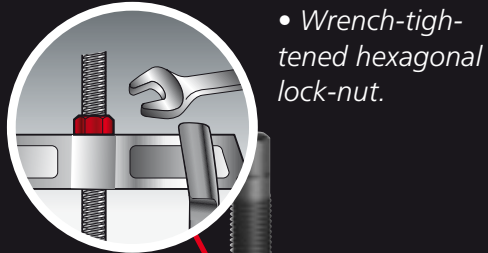

• Wrench-tightened hexagonal lock-nut.

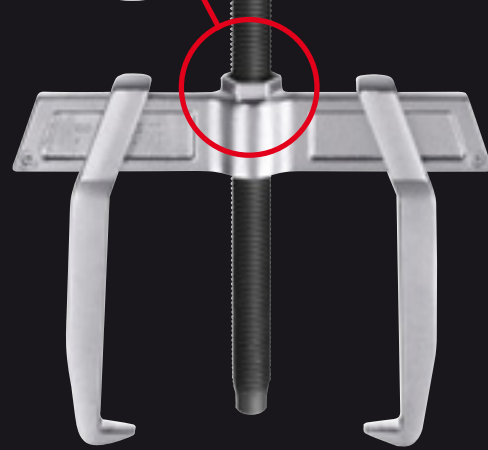

Leg reversal

• Legs changed from inside grip to outside grip configuration simply by pressing the pin. No need for tools.



Safety first

Leg retainer

• A spring-loaded pin at the end of the beam prevents the legs sliding off.

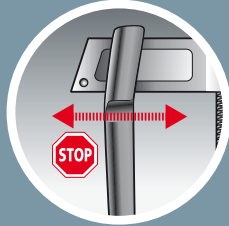

Leg locking

• The legs are designed to cantilever during pulling, blocking them in place and preventing them sliding along the beam.



U.232 - 2-leg sliding-leg puller

➤	C mini - maxi mm	P maxi mm	T Tonnes	T kN	Legs	Screw	mm	ΔΔ kg
U.232-65	25 - 65	65	1,5	15	U.232G1	U.35P01	13	0,4
U.232-90	30 - 90	100	3	30	U.232G2	U.35SE1	17	0,9
U.232-130	45 - 130	100	3	30	U.232G2	U.35SE1	17	1,0
U.232-160	45 - 160	145	4	40	U.232G3	U.53S2A7	16	2,8
U.232-210	45 - 210	145	4	40	U.232G3	U.53S2A7	16	3,0
U.232-270	65 - 270	190	5	50	U.232G4	U.53S3-07	21	7,5
U.232-340	65 - 340	190	5	50	U.232G4	U.53S3-07	21	8,2

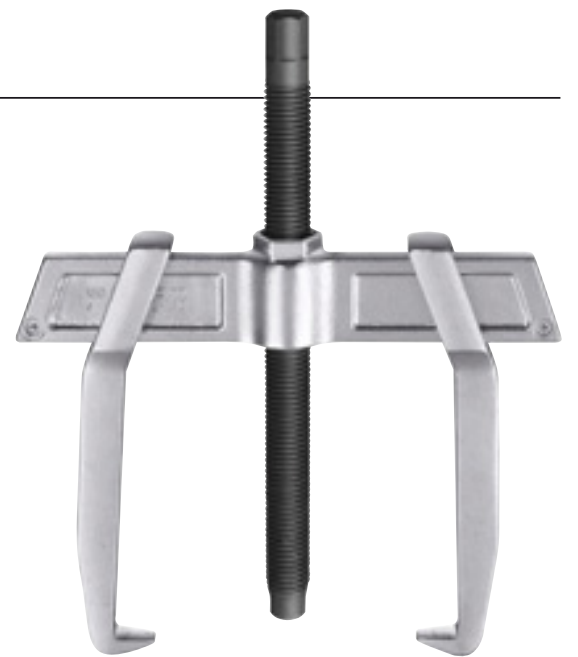
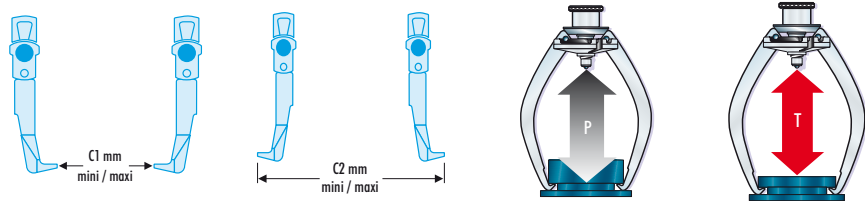

U.232G Spare legs for U.232 pullers

- For your safety, we recommend that all the legs are replaced in the event of a problem.
- Legs supplied individually.

➤	L mm	a mm	b mm	c mm	d mm	Puller	ΔΔ kg
U.232G1	100	4	10	10	15	U.232-65	0,08
U.232G2	155	6	10	14	23	U.232-90 / U.232-130	0,19
U.232G3	225	8	14	21	31	U.232-160 / U.232-210	0,56
U.232G4	303	12	17	25	43	U.232-270 / U.232-340	1,57

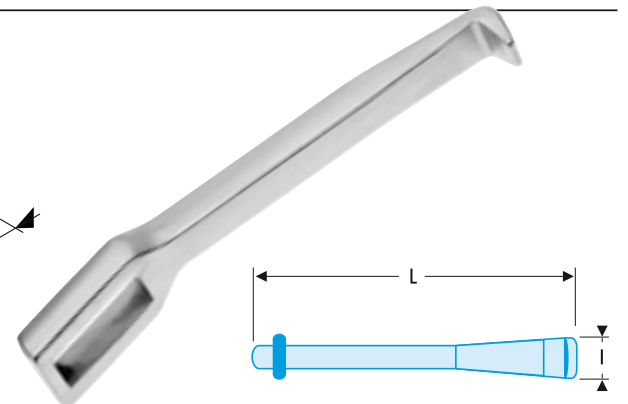
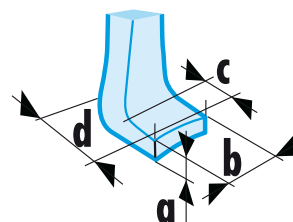

Outside pullers - 2 legs

U.232V Spare screws for U.232 pullers

- Screws supplied singly.

Ref	Ø mm	L mm	Ø mm	Puller	ΔΔ kg
U.35P01	M12	133	13	U.232-65	0,08
U.35SE1	M16	180	17	U.232-90 / U.232-130	0,20
U.53S2A7	M20	283	16	U.232-160 / U.232-210	0,47
U.53S3-07	M27	344	21	U.232-270 / U.232-340	1,28

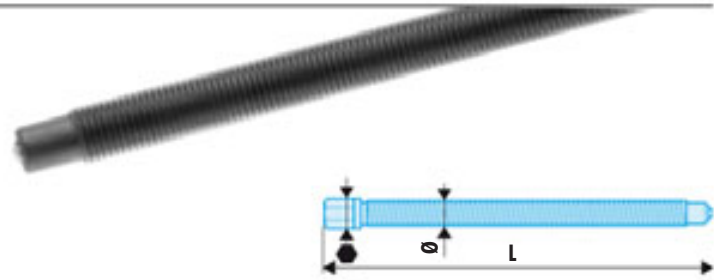

► Slim 2-leg pullers

U.14 Self-gripping slim 2-leg pullers

- Spring loaded, self-gripping 2-leg puller.
- Can be used for disconnecting battery terminals.

Ref	C mini - maxi mm	P maxi mm	T Tonnes	T kN	Dimensions mm	ΔΔ kg
U.14A	10 - 35	40	0,5	5	70 x 112 x 35	0,31
U.14L	10 - 45	60	0,5	5	85 x 150 x 38	0,36

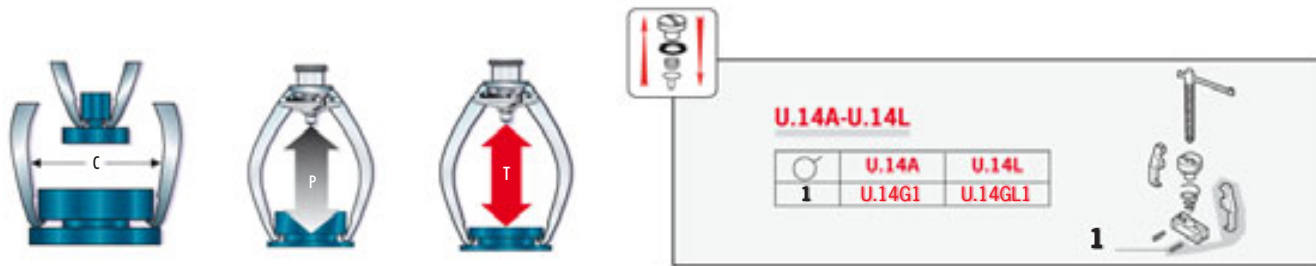

U.301 Self-gripping 2 slim-leg puller

- Spread : 80, 150 and 200 mm.
- Can be used with slide hammer U.49AM using adaptor U.301E1 (U.301 and U.301-150) or adaptor U.301E2 (U.301-200).

Ref	Screw	C mini - maxi mm	P maxi mm	T Tonnes	T kN	Legs	Ø mm	ΔΔ kg
U.301	U.301-04	10 - 80	90	0,9	9	U.301G	10	0,46
U.301-150	U.301-04-150	10 - 150	150	0,9	9	U.301G150	10	0,67
U.301-200	U.301-04-200	10 - 200	200	1,3	13	U.301G200	13	1,10

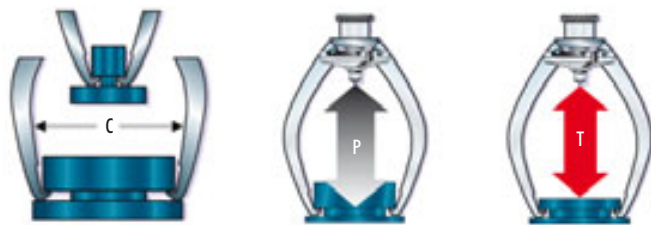

Spare legs for puller U.302

- For your safety, we recommend that all the legs are replaced in the event of a problem.
- Legs supplied individually.

Ref	L mm	a mm	b mm	c mm	d mm	Puller	ΔΔ kg
U.301G	130	5	8	7	16	U.302	0,60
U.301G-150	205	6	8	7	17	U.302-150	0,84
U.301G-200	270	6	8	7	18	U.302-200	0,40

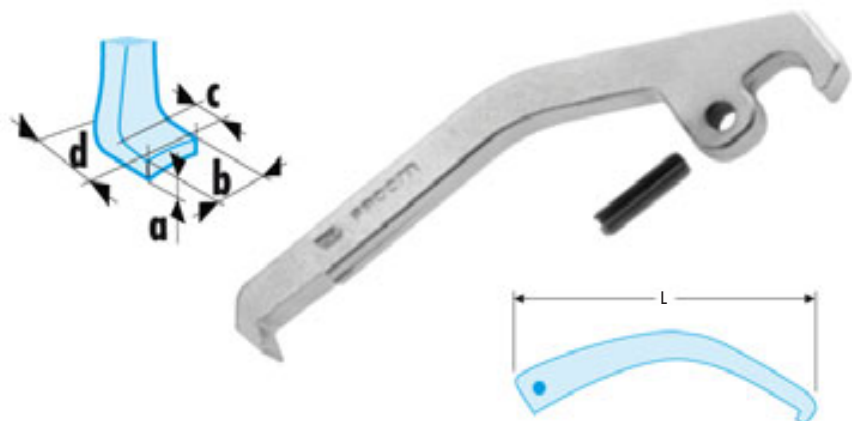

Wide 2-leg pullers

New

U.301 L/M/P - Wide 2-leg puller

A COMPACT PULLER WITH TWO "WRAP AROUND" LEGS FOR A BETTER GRIP

Effective and easy to use

- Self-gripping, self-centring "body and spring" system.



- 1/ Force-limiting safety rod.
- 2/ Ergonomic finger grips allowing one-handed installation
- 3/ Shear pin.
- 4/ "Wrap-around" legs to grip the part firmly without scratching
- 5/ "Positive" leg angle for optimum grip even under maximum pulling force. Spread : 50, 100 and 110 mm.



Safety first

- The rod (1), then the shear pin (3) fail in stages before the yield point of the legs is reached.



U.301 Self-gripping wide 2-leg puller

- Spread : 50 mm, 100 mm and 110 mm.
- Can be used with slide hammer U.49AM using adaptor U.301E1 (U.301P and U.301M) or adaptor U.301E2 (U.301L).
- Load limiter collapses under excessive applied force.

➤	C min - max mm	P mm	ΔΔ g
U.301P	15 - 50	70	540
U.301M	15 - 100	100	800
U.301L	15 - 110	130	930

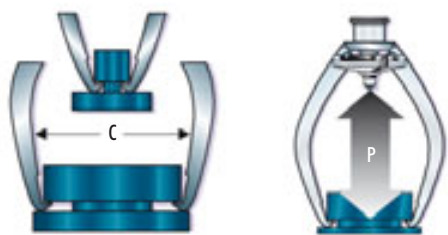

Outside pullers - 2 legs

U.35 Wide 2-leg pullers

- For removing bearings, sprockets and flywheels.
- "Cross-legged" configuration recommended.
- Optional "uncrossed-legged" configuration doubles capacity.
- Puller accessories (sold separately) : slide hammer U.306M for U.35 and U.35L

Model	C mini - maxi mm	P maxi mm	T Tonnes	T kN	Screw	Ø mm	L mm	mm	ΔΔ kg
U.35P	10 - 55	75	1	10	U.35P01	M12	133	13	0,39
U.35	15 - 75	90	4	40	U.35SE1	M16	180	17	0,99
U.35L	15 - 75	130	3	30	U.35SE1 + U.35SE3	M16	180	17	1,22

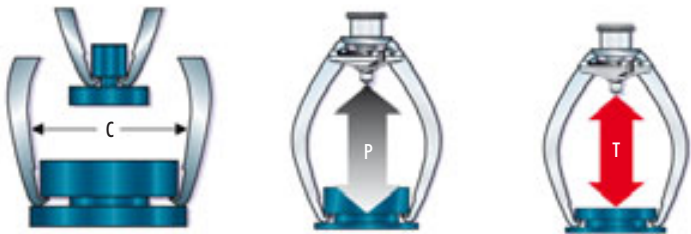

U.35-U.35L

Model	1	2
U.35		U.35C
U.35L	U.35B	



Heavy-duty 2-leg pullers

U.34

- Spread : Ø 40 mm to Ø 180 mm.
 - Reach : 245 mm.
 - Maximum pulling force : 7 tonnes, 70 kN.
 - Puller accessory (supplied separately) : slide hammer U.2.
- ΔΔ : 4.4 kg.

Model	Screw	C mini - maxi mm	P maxi mm	T Tonnes	T kN	Small legs	Large legs	mm	ΔΔ kg
U.34	U.20B1	40 - 180	245	7	70	U.34-2B3	U.34-2A3	24	4,4

U.34

Part	Model
1	U.20B1
2	U.34-2A3



U.42 Pullers with yokes

- Model U.42B has special-purpose legs for gearbox bearings.
- Spare yoke for U.42 and U.42B : U.42SE2.

Model	C mini - maxi mm	P maxi mm	T Tonnes	T kN	Legs	Screw	mm	ΔΔ kg
U.42	10 - 85	120	1,5	15	U.42-3	U.42-1	13	1,3
U.42B	10 - 85	180	1,5	15	U.42B3	U.42-1	13	1,6



U.42-U.42B

Part	U.42	U.42B
1	U.42-1	U.42-1
2	U.42-3	U.42-B3
3	U.42SE2	U.42SE2



Puller with yoke

U.52

- Spare yoke for U.52 : U.52SE2.
- ΔΔ : 1,68 kg.

Model	C mini - maxi mm	P maxi mm	T Tonnes	T kN	Legs	Screw	mm	ΔΔ kg
U.52	10-150	160	6	60	U.52-3	U.52-1	17	1,7



U.52

Part	U.52
1	U.52 1
2	U.52 3
3	U.52SE2



Pulley puller

DM.31

- For removing crankshaft pulley by gripping the pulley grooves.
 - Pulley capacity : Ø 130 to 156 mm.
- ΔΔ : 1.05 kg.

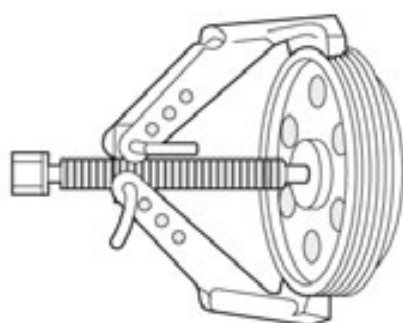

▶ Tip-type pullers, cage grip



U.23 - Tip type pullers, cage grip



- The design of this puller is particularly suited to cage-type ball bearings.
- Pressure is distributed over the two races and the tool can be used for both shaft and housing fits.
- Depending on the ball diameter, different pairs of spherical tips should be selected from one of three sets available.

Positioning tips in bearings

- Drill 2 diametrically opposed holes.
- Bend back cage ends.
- Insert appropriately sized tips into race.
- Turn through 90 degrees to lock.
- Screw beam rods into tips.

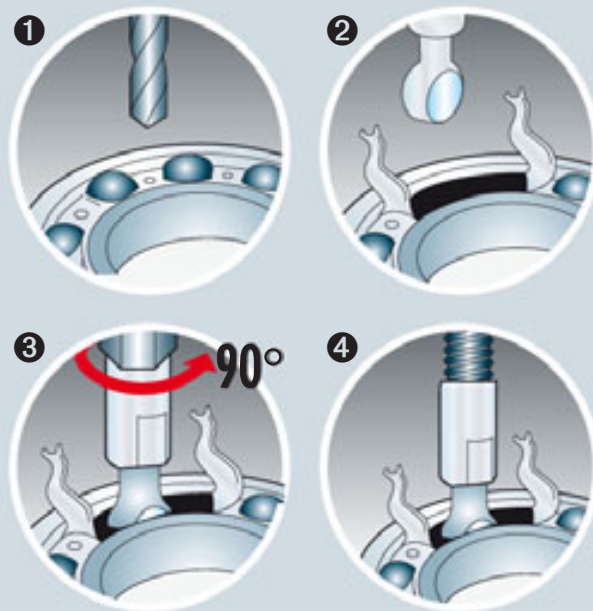

Micro-engineering puller kit

U.23J1A

- Comprising :
 - 3 pairs of tips \varnothing 5.5 - 6 - 7.5 mm.
 - Beam U.23K1A.
- Spread : \varnothing 25 mm to \varnothing 95 mm.
- For ISO bearings : 6004 to 6010, 6200 to 6205, 6300 to 6302.
- Supplied in plastic case BP 102 and tray PL.392A.
- $\Delta\Delta$: 800 g.



Light engineering puller kit

U.23J2

- Comprising :
 - 3 pairs of tips \varnothing 9 - 11 - 12.5 mm
 - Beam U.53K1.
- Spread : \varnothing 40 mm to 110 mm.
- For ISO bearings : 6206 to 6211, 6303 to 6307, 6403 to 6404.
- Supplied in plastic case BP.115 and tray PL.71A.
- $\Delta\Delta$: 1.84 kg.



General engineering puller kit

U.23J3

- Comprising :
 - 6 pairs of tips \varnothing 16 - 19 - 22 - 25 - 28 - 32 mm
 - Beam U.53K2.
- Spread : \varnothing 70 mm to 190 mm.
- For ISO bearings : 6212 to 6222, 6308 to 6319, 6405 to 6414.
- Supplied in plastic case BP.109 and tray PL.104A.
- $\Delta\Delta$: 7.3 kg.



U.23D Pair of tips

⇒	N° tip	Tapping	Ø mm	ΔΔ g	⇒	N° tip	Tapping	Ø mm	ΔΔ g		
	U.23D5	1	M6	5,5	26		U.23D16	7	M16	16,0	125
	U.23D6	2	M6	6,0	27		U.23D19	8	M16	19,0	275
	U.23D8	3	M6	7,5	30		U.23D22	9	M16	22,0	315
	U.23D9	4	10	9,0	39		U.23D25	10	M16	25,0	487
	U.23D11	5	10	11,0	44		U.23D28	11	M16	28,0	525
	U.23D12	6	10	12,5	45		U.23D32	12	M16	32,0	669

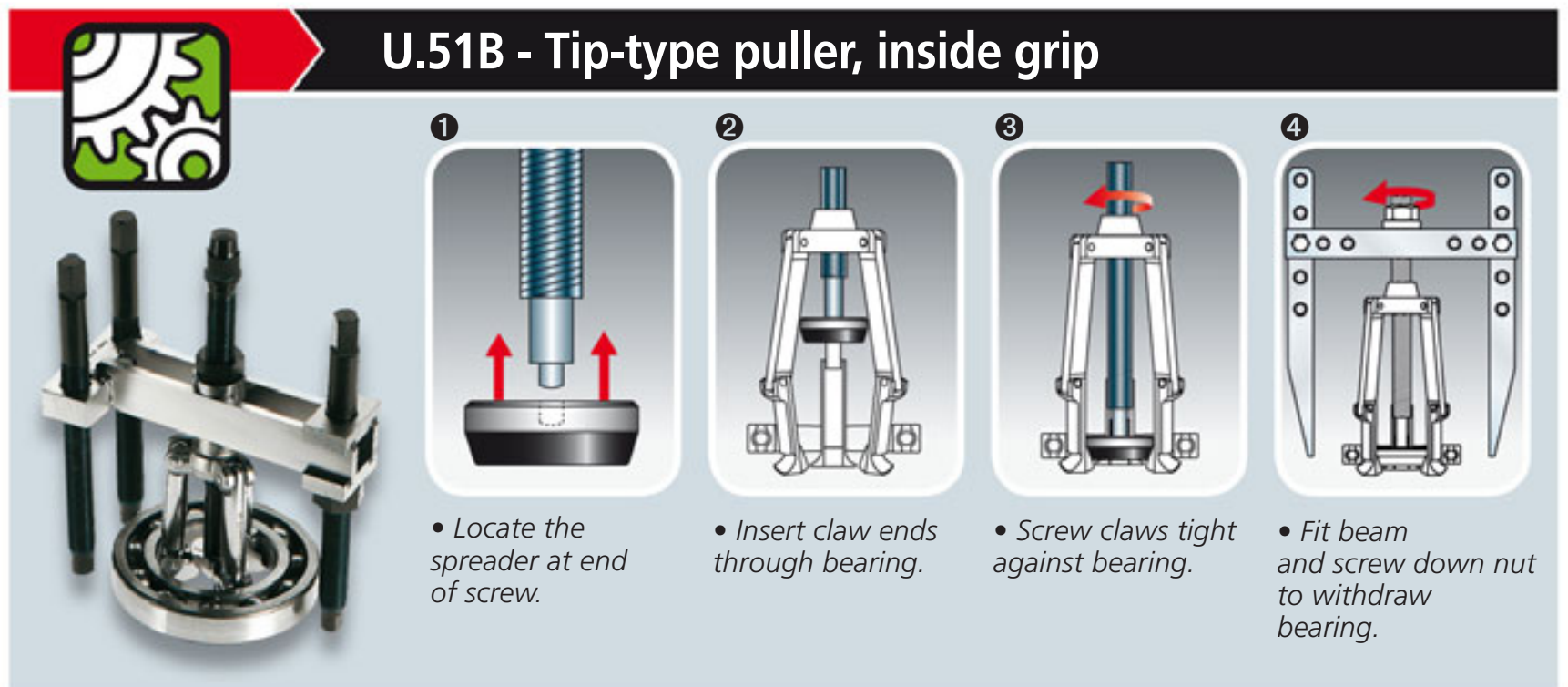

▶ **Tip-type pullers, inside grip****Inside grip puller****U.51B**

- Spread : Ø 32 mm to 70 mm.
 - Puller accessories : beam U.40 or U.30.
 - Complete with 15 spreaders.
 - Supplied in plastic case BP 109 and tray PL.710.
- ΔΔ : 3.4 kg.

**Inside grip puller****U.28**

- Spread : Ø 70 mm to 160 mm.
 - Spreader application sizes :
 - spreader U.28-8 : 70-100 mm
 - spreader U.28-9 : 100 - 136 mm
 - spreader U.28-10 : 130-160 mm.
 - Puller accessories : slide hammer U.2, beam U.40 or U.30.
- ΔΔ : 3.3 kg.

**Beam for pullers U.28 and U.51B****U.30**

- For pullers U.28 and U.51B
- ΔΔ : 4.64 kg.

**Inside grip puller and beam kit****U.28J1**

- Comprising :
 - 1 puller U.28
 - 1 beam U.30.
 - Spread : Ø 70 mm to 160 mm.
 - Supplied in steel case BT.111 (396 x 224 x 82 mm) + tray PL.168.
- ΔΔ : 9.5 kg.



► Expansion-type pullers, inside grip

U.49P inside grip expansion pullers

- More impact-resistant and durable.
- Multiple blades, more flexible and less prone to deformation.
- Easier to use.
- Increased spread.

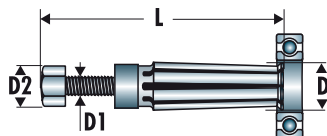

►	D mm (mini)	D mm (maxi)	L mm maxi	D2 mm	D1 mm	ΔΔ kg
U.49P1	6,5	8	76	12	M8	0,028
U.49P2	8,5	10	76	12	M8	0,030
U.49P3	10,5	13	88	12	M8	0,042
U.49P4	13	18	100	12	M8	0,068
U.49P5	18	22,5	112	17	1/2"	0,142
U.49P6	22,5	30	139	17	1/2"	0,298
U.49P7	30	38	158	22	1/2"	0,546
U.49P8	38	50	190	1-1/4"	1/2"	1,216
U.49P9	50	60	190	1-1/4"	1/2"	1,424
U.49AD10	70	110	169	10	G 3/8"	1,600

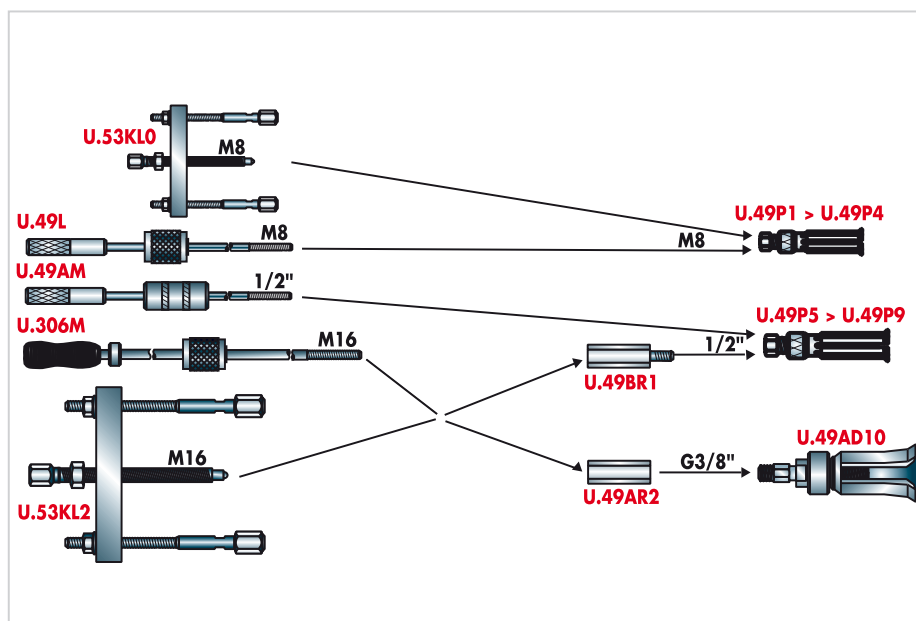

Maintenance puller kit

U.49PJ1

- For bearings Ø 8 to 38 mm.
- Comprising :
 - Set of 6 expansion pullers U.49P2 to U.49P7.
 - 2 beams U.53KL0 and U.53KL2.
 - Adaptor U.49BR1.
- Supplied in a plastic case with tray PL.711.

►	Dimensions mm	ΔΔ kg
U.49PJ1	480 x 240 x 75	3,5



Light-engineering puller kit

U.49PJ2

- For bearings Ø 18 to 50 mm.
- Comprising :
 - 4 expansion pullers U.49P5 to U.49P8.
 - 1 slide hammer U.49AM.
- Supplied in plastic case BP.109 and tray PL.712.

►	Dimensions mm	ΔΔ kg
U.49PJ2	480 x 240 x 75	5,0



Light-engineering puller kit

U.49PJ3

- For bearings \varnothing 6 to 18 mm.
- Comprising :
 - 4 expansion pullers U.49P1 to U.49P4.
 - 1 slide hammer U.49L.
- Supplied in plastic case BP.109 and tray PL.445.

	Dimensions mm	$\Delta\Delta$ kg
U.49PJ3	330 x 140 x 75	1,4



Heavy-duty puller set

U.49PJ4

- For bearings \varnothing 30 to 60 mm.
- Comprising :
 - 3 expansion pullers U.49P7 to U.49P9.
 - 1 beam U.53KL2.
 - Adaptor U.49BR1.
- Supplied in plastic case BP 109 and tray PL.713.

	Dimensions mm	$\Delta\Delta$ kg
U.49PJ4	480 x 240 x 75	5,3



Adapter U.49P

U.49BR1

- Female thread : M16 X 200.
- Male thread : 1/2".

	\varnothing mm	$\Delta\Delta$ g
U.49BR1	16 1/2"	101

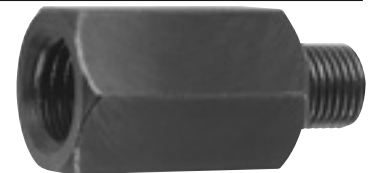

Adapter U.49AD10

U.49AR2

- Female threaded adaptors to fit expansion puller U.49AD10 to slide hammers and centre beam screws.
- Female thread M16x200 and G3/8".
- Length : 75 mm.

	\varnothing mm	$\Delta\Delta$ g
U.49AR2	16 - G3/8"	108



Adaptors for attaching U.301 / U.302 to U.49AM

- U.301E1 adaptor for puller U.301, U.302, U.301-150, U.302-150.
- U.302E2 adaptor for puller U.301-200 and U.302-200.
- Locks the legs in position for pulling.

	$\Delta\Delta$ g
U.301E1	233
U.301E2	320

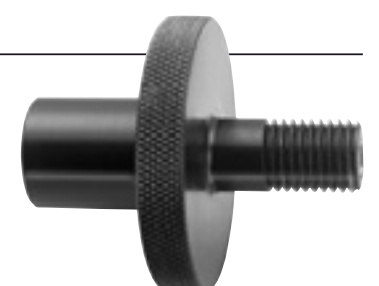

Slide hammers

Slide hammer

U.306M

- Fits pullers type U.306, U.42, U.42B, U.32T2-8, U.32T2-12, U.35, U.35L.
 - Puller accessories : (supplied separately).
 - Expansion pullers U.49P5 to U.49P9 with adaptor U.49BR1.
 - Expansion puller U.49AD10 with adaptor U.49AR2.
 - Male adaptors U.53E4 to U.53E14 with female adaptor U.53H2.
- $\Delta\Delta$: 2.7 kg.

	L mm	L1 mm	L2 mm	Ø weight mm	Thread
U.306M	660	530	210	60	M16

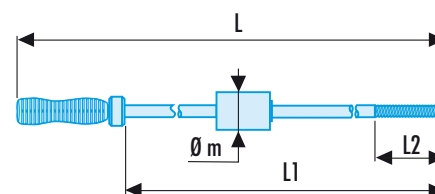

Slide hammer

U.49L

- For use with light duty expansion pullers U.49P1 to U.49P4.
 - For bearing inner Ø 6 to 18 mm.
 - Weight 200 g. Length : 300 mm
- $\Delta\Delta$: 430 g.

	L mm	L1 mm	L2 mm	Ø weight mm	Thread
U.49L	300	210	15	30	M8

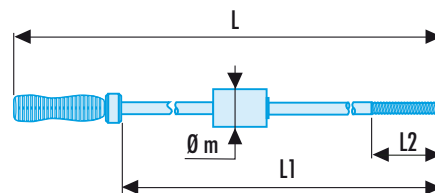

Slide hammer

U.49AM

- For use with expansion pullers U.49P5 to U.49P9.
 - For bearing inner Ø 18 to 60 mm.
 - Can be used with male adaptors U.53E4 to U.53E14 with female adaptor U.53H3.
 - Weight 1 kg. Length : 450 mm.
- $\Delta\Delta$: 1.6 kg.

	L mm	L1 mm	L2 mm	Ø weight mm	Thread
U.49AM	450	320	20	45	1/2"

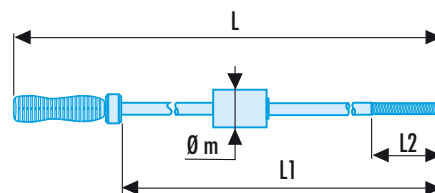

Slide hammer

U.2

- Thread M 22 x 200.
 - Length : 760 mm.
 - For use with U.20, U.20B, U.310, U.32T6-16, U.32T6-20, U.28 and plate assembly U.9.
- $\Delta\Delta$: 8 kg.

	L mm	L1 mm	L2 mm	Ø weight mm	Thread
U.2	760	600	70	91 / 170	M22

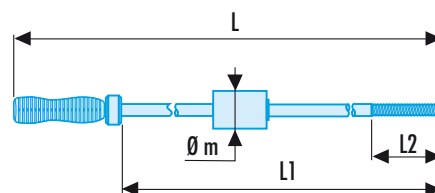

► Puller kits



U.53 - Separators, flush grip



Bearing separators U.53T fit behind races where ordinary puller claws will not reach.

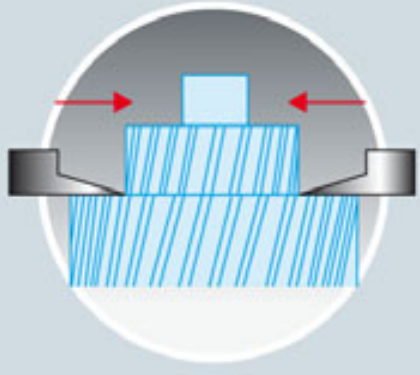

- The wedge-shaped jaws bear against the back of the fitting, pushing it out as they close.
- Separators can be used with beams for mechanical screws or with beams designed specifically for use with hand-operated hydraulically-assisted jacks.

! Safety first

- Only hand-operated hydraulic systems are to be used in conjunction with separator and beam combinations.

Separator and beam with hand-operated hydraulic system.

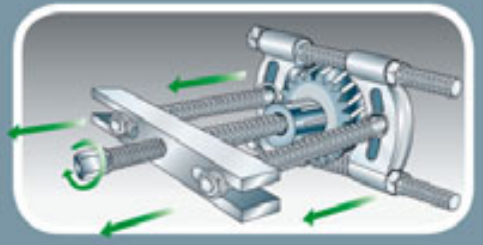

Separator and beam with mechanical screw.

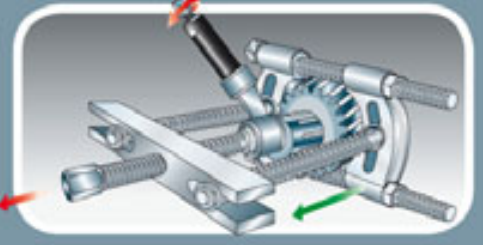

- Beam used with hydraulic press U.33A.
- Only to be used with beams U.53K4 and U.53S4A.

60 mm separator and beam puller kit**U.53J1**

- Comprising :
 - 1 separator U.53T1, capacity = \varnothing 5 to 60 mm.
 - 1 beam puller U.53K1, spread = \varnothing 40 to 110 mm.
- Max. reach : 180 mm.
- 8 sets of male adaptors U.53E M4 - M5 - M6 - M8.
- 2 female adaptors U.53H1.
- Supplied in a plastic case BP.112 and tray PL.296A.
- $\Delta\Delta$: 3.4 kg.

**110 mm separator and beam puller kit****U.53J2**

- Comprising :
 - 1 separator U.53T2, capacity = \varnothing 15 to 110 mm.
 - 1 beam puller U.53K2, spread = \varnothing 70 to 200 mm.
- Max. reach : 240 mm.
- 8 sets of male adaptors U.53E M8-M10-M12-M14.
- 2 female adaptors U.53H2.
- Supplied in plastic case BP.109 and tray PL.297A.
- $\Delta\Delta$: 7.3 kg.



Separators and beam pullers

► Separators

U.53T Separators

➤	D mini - maxi mm	L mm	l mm	Ø T mm	Ø M mm	For ➤	ΔΔ kg
U.53T1	5-60	140	91	M12	M10	U.53K1	0,6
U.53T2	15-110	215	153	M16	M16	U.53K2 U.53S2A	2,3
U.53T3	15-150	290	204	M20	M20	U.53K3	5,1
U.53T4	20-180	360	289	M22	M22	U.53K4 U.53S4A	8,8
U.53T5	25-250	430	316	M22	M22	U.53K4 U.53S4A	11,3

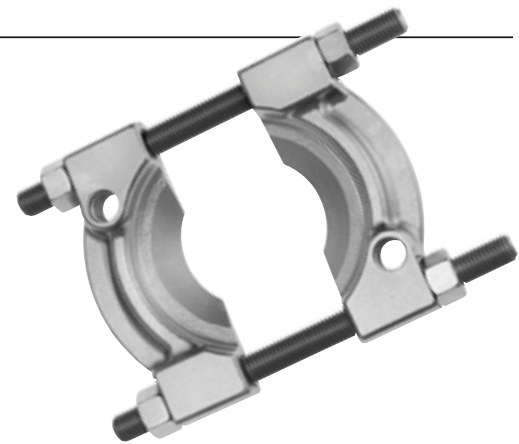
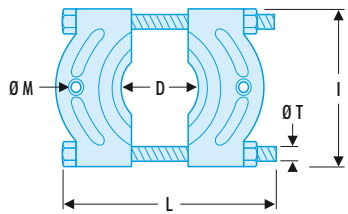

U.23/U.53 - Beam pullers

Beams can be used with different types of puller :

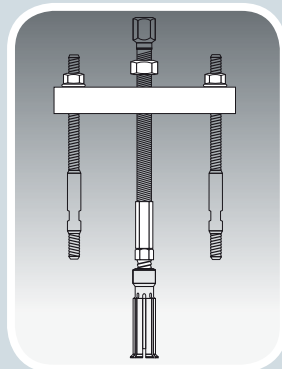

• Expansion bearing puller U.49P.

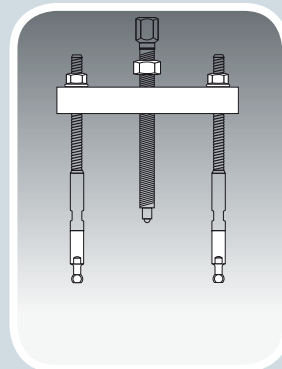

• Spherical or threaded tip pullers U.23.

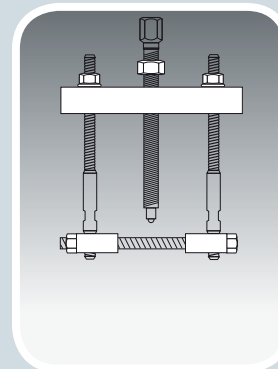

• Separator U.53

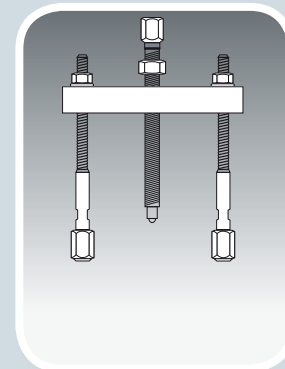

• Extraction via beam alone.

► Beams

U.23K, U.53K tapped beams

- Tapped beams, spread Ø 25 mm to 400 mm.
- For use with separators and spherical or threaded tips.

➤	C mm	P mm	L mm	l mm	h mm	d mm	Ø1	mm	ΔΔ kg
U.23K1A	25-95	100	105	20	20	155	M10	8	0,4
U.53K1	40-110	180	135	25	25	217	M16	11	0,4
U.53K2	70-200	240	220	30	30	283	M16	11	0,84
U.53K3	75-280	300	320	45	35	283	M20	16	2,4
U.53K4	145-400	350	450	50	50	343	M27	21	5,5

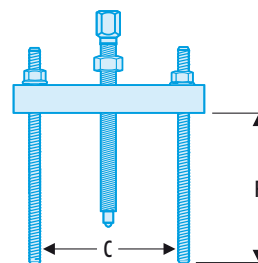
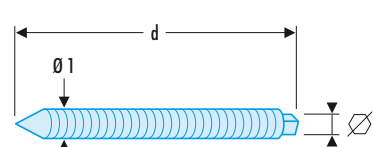
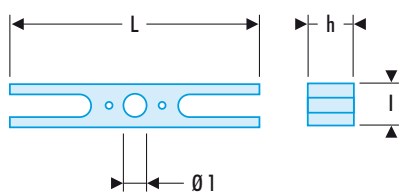

U.53KL Non-tapped beams

- For removing bearings with expansion pullers U.49P1 to U.49P9 and U.49AD10
- U.53KL0 :
 - for expansion pullers U.49P1 to U.49P4.
- U.53KL2 :
 - for expansion pullers U.49P5 to U.49P9 using adaptor U.49BR1.
 - for expansion pullers U.49AD10 using adaptor U.49AR2.

	C	P	L	l	h	d	Ø1	mm	ΔΔ
	mm	mm	mm	mm	mm	mm			g
U.53KL0	25-100	125	110	20	20	8,5	M8	6	405
U.53KL2	70 - 200	240	220	30	30	283	M16	11	840

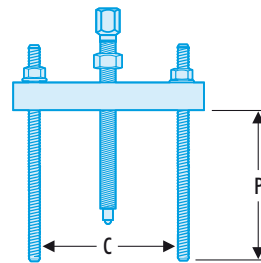
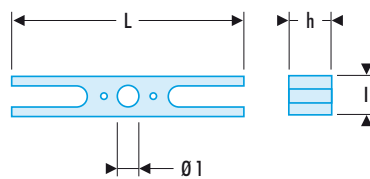
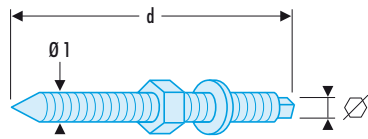

U.53S Beams for use with jacks

- These 2 non-tapped beams have higher mechanical strength than U.53K versions (size, steel grades and heat treatment), to withstand greater stresses generated by hydraulics.

	Force	C	L	l	h	d	Ø1	ΔΔ
	kN	mm	mm	mm	mm	mm		kg
U.53S	100	120 - 200	283	35	35	280	M20	0,47
U.53S4A	300	170 - 400	450	60	60	420	M33	8,500

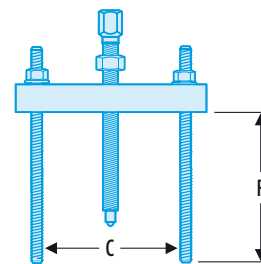
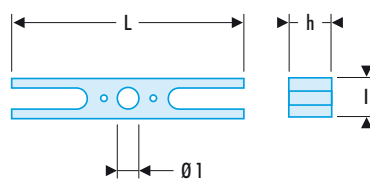
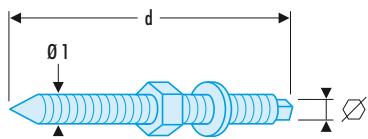

U.53RL Spare tie-rods for beams

- Tie-rods supplied individually, to be ordered in pairs.

	Ø	For	L
			mm
U.53R1L	M10	U.53K1	205
U.53R2L	M16	U.53K2, U.53KL2	275
U.53R3L	M20	U.53K3	350
U.53R4LA	M22	U.53K4, U.53S4A	420

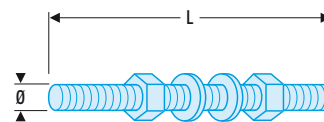

▶ Beam puller accessories

U.53E Male adaptors

	Ø	L	ΔΔ
	mm	mm	g
U.53E4	4	33,5	50
U.53E5	5	35,5	50
U.53E6	6	36,5	50
U.53E8	8	39,5	50
U.53E10	10	42,5	55
U.53E12	12	46,5	60
U.53E14	14	48,5	70

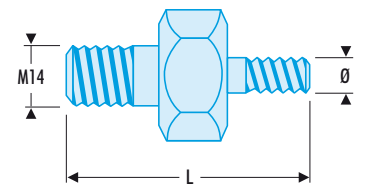

U.53H Female adaptors to fit male adaptors

	Ø	ΔΔ
	mm	g
U.53H1	10	130
U.53H2	16	110
U.53H3	1/2"	120

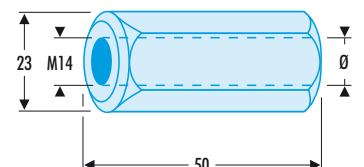

Stud extractors - nut splitters

▶ Stud extractors



285 - Stud extractors

FOR REMOVING SHEARED RIGHT-HAND THREAD STUDS

- 285 stud extractors are designed exclusively for use on right-hand thread studs (99% of cases).
- The extractors' tapered shape requires the use of cone bits. Using traditional cylindrical bits reduces the contact surface between the extractor and the stud, greatly increasing the risk of the extractor breaking in the stud.

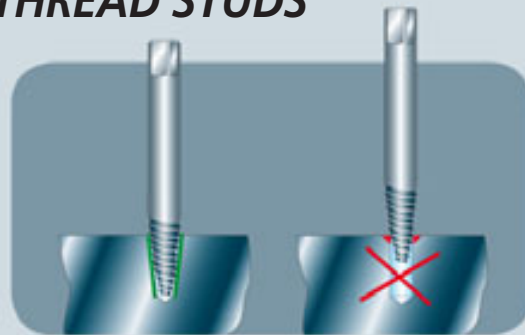

- Choose the extractor and corresponding drill bit according to the diameter of the stud to be removed.



- Drill with a 285.F cone bit.



- Push in then unscrew using the corresponding stud extractor.



- The stud is removed

285.J Set of right-hand thread stud extractors

- 285.J10 : Set of 5 stud extractors, 5 cone bits and a tap wrench 831.1 (for use with the 4 smaller extractors only).
- Supplied in a plastic case BP.102 (204 x 122 x 52 mm). Tray PL.464.
- 285.JS10 : Set of 5 stud extractors and 5 cone bits on a stand.
- 285.JS5 : Set of 5 stud extractors on a stand.

285.J10



285.JS5



285.JS10

Icon	Ø mini - maxi mm	mm	Storage	N° 285	N° 285F	ΔΔ g
285.J10	3 - 18	204 x 122 x 52	BP.102 + PL.464	4, 5, 6, 8, 11	F1, F2, F3, F4, F5	470
285.JS10	3 - 18	100 x 90 x 25	CKS.25A x 2	4, 5, 6, 8, 11	F1, F2, F3, F4, F5	290
285.JS5	3 - 18	100 x 90 x 25	CKS.25A	4, 5, 6, 8, 11	-	150

285 Single right-hand thread stud extractors

- Helical extractors for removing sheared studs after drilling down the centre with bits 285.F.

Icon	Ø 1 mini - maxi mm	Ø 2 mini - maxi mm	Cone bits 285.F	L mm	□ mm	ΔΔ g
285.4	3 - 6	2,2 - 3,4	285.F1	55	3,0	5
285.5	6 - 8	3,7 - 4,3	285.F2	60	4,0	8
285.6	8 - 11	4,5 - 5,3	285.F3	65	4,5	12
285.8	11 - 14	6,2 - 7,1	285.F4	75	6,0	25
285.11	14 - 18	8,6 - 9,8	285.F5	85	8,5	52
285.14	18 - 24	11 - 12,5	-	90	10,0	86
285.18	24 - 33	14,5 - 16	-	105	14,0	166
285.25	33 - 50	20 - 22,5	-	120	18,0	348

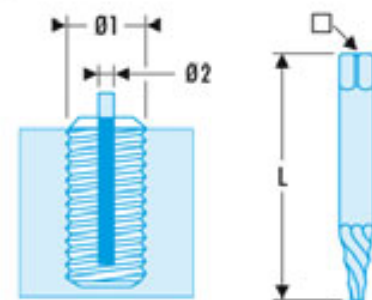

285.F Single cone bits for extractors 285

Icon	For extractor 285	Length mm	Ø mm	ΔΔ g
285.F1	285.4	57	3,5	5
285.F2	285.5	63	4	6
285.F3	285.6	67	5,5	11
285.F4	285.8	80	7,5	23
285.F5	285.11	86	10	43





885 - Stud extractor

FOR REMOVING SHEARED RIGHT-HAND, OR LEFT-HAND THREAD STUDS

- 885 stud extractors are designed exclusively for use on right-hand or left-hand thread.
- The splined rod has a cylindrical shape and can be drilled using standard (cylindrical) drill bits.



- Choose the extractor and corresponding drill bit according to the diameter of the stud to be removed.



- Drill with a standard 222A.T bit. Insert the splined bit using a mallet 216.40.



- Install the hexagonal shoulder. Loosen with a wrench.



- The stud is removed

Set of right-hand or left-hand thread stud extractors

885

- Extraction by pre-drilling and inserting a splined bit driven via its hexagon shoulder.
 - Stud \varnothing 6 mm to \varnothing 14 mm.
 - Right or left-hand thread.
 - Supplied in a case 165 x 130 x 25 mm.
- $\Delta\Delta$: 540 g.



Components for 885 set

885.F : Drill bits.

885.EH : Extractors.

⇒	Length	Ø		$\Delta\Delta$
	mm	"	mm	
885.F1	65	1/8	3,17	3
885.F2	85	3/16	4,76	8
885.F3	100	1/4	6,35	17
885.F4	115	5/16	7,94	30
885.F5	120	11/32	8,73	40
885.EH1		1/4	6	13
885.EH2		5/16	8	20
885.EH3		3/8	10	33
885.EH4		7/16	12	46
885.EH5		1/2	14	60



▶ Stud drivers

286A Knurl-type stud drivers - Multi-diameter

- Select the right hole for the stud diameter.
- Tighten or loosen : the offset knurl grips the stud, allowing it to be tightened or loosened.

⇒	Capacity Ø	Dimensions	"	□	$\Delta\Delta$
	mm	mm		mm	g
286A	5 - 20	52 x 54	1/2	12,7	400
286A.PL	15 - 27	72 x 66	3/4	19,05	950

⇒	Description
286A.M	Spare knurled wheel for 286A



Stud extractors - nut splitters

287B Roller-type stud drivers - Single-diameter

- Capacity : $\varnothing 6 \text{ mm} > \varnothing 16 \text{ mm}$.
- Turned by means of the hexagonal drive or a $\frac{1}{2}$ " - 12.7 mm ratchet.
- Except model 287B.16, which has a through-hole for a bar.
- For tightening or loosening studs.

➤	Capacity mm	D x L mm	⊙ mm	ΔΔ g
287B.6	6	25 x 65	22	167
287B.7	7	25 x 65	22	166
287B.8	8	25 x 65	22	168
287B.9	9	29 x 75	22	246
287B.10	10	29 x 75	22	242
287B.12	12	29 x 75	22	241
287B.14	14	34 x 75	27	308
287B.16	16	34 x 75	27	340

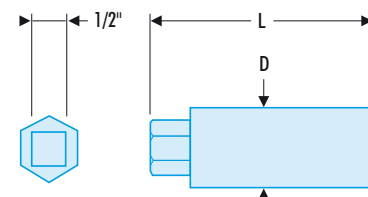

Set of roller-type stud drivers

287B.JS5

- 5 stud drivers for sizes M6, M7, M8, M9 and M10 (287B.6 to 287B.10).
- Supplied in a rack (CKS.73A).
- Dimensions : 155 x 175 x 35 mm.
- ΔΔ : 1.12 kg.



▶ Nut splitter

289 Nut splitters

- For splitting a worn or jammed nut without damaging the screw thread.

➤	⊙ mini - maxi mm	⊙ M1 mm	⊙ mm	d mm	D mm	L mm	ΔΔ kg
289.19	2 - 8	14 x 150	4 - 13	19	31	92	0,267
289.30	10 - 16	14 x 150	17 - 24	30	50	104	0,310
289.36	18 - 20	20 x 150	24 - 30	36	62	156	1,165
289.54	20 - 30	27 x 300	30 - 30	50	90	198	2

➤	Description
289.V1	Spare screw for 289.19 and 289.30
289.V2	Spare screw for 289.36
289.V3	Spare screw for 289.54

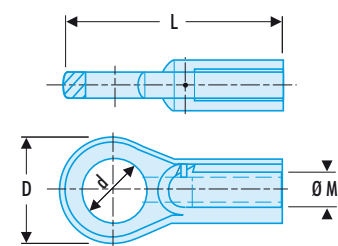

Set of 2 nut-splitters for sizes M2 to M8 and M10 to M16

289

- Comprising :
 - body 289.19.
 - body 289.30.
 - screw 289.V1.
- Supplied in a plastic tray (PL.173) = 155 x 75 x 35 mm.
- ΔΔ : 871 g.

