

Pre / power amplifier and motor governor for 3V headphone stereos

BA3528AFP / BA3529AFP

The BA3528AFP and AB3529AFP have been developed for headphone stereos. They run off a 3V power supply, and include dual pre- and power amplifiers, and a motor governor.

The preamplifiers are direct-coupled, and the power amplifiers use a fixed-gain NF circuit. An on-chip V_{REF} amplifier makes output coupling capacitors unnecessary, and the motor governor uses a bridge ratio system to minimize the external parts count and make reliable and compact designs possible.

●Applications

3V portable stereo equipment

●Features

- 1) All the functions required for headphone stereo units on a single chip.
- 2) Preamplifier includes a mute amplifier.
- 3) Direct-coupled preamplifier.
- 4) No output coupling capacitors required for the power amplifiers.
- 5) Power amplifiers do not require oscillation prevention measures.
- 6) Power amplifier gain allows use of noise reduction (BA3529AFP).

●Absolute maximum ratings ($T_a = 25^\circ\text{C}$)

Parameter	Symbol	Limits	Unit
Power supply voltage	V_{CC}	6	V
Power dissipation	P_d	1.7*	W
Operating temperature	T_{opr}	$-25 \sim +75$	$^\circ\text{C}$
Storage temperature	T_{stg}	$-55 \sim +150$	$^\circ\text{C}$

* Reduced by 13.6mW for each increase in T_a of 1°C over 25°C (when mounted on a 90mm \times 50mm \times 1.6mm glass epoxy board).

●Recommended operating conditions ($T_a = 25^\circ\text{C}$)

Parameter	Symbol	Min.	Typ.	Max.	Unit
Power supply voltage	V_{CC}	1.8	3.0	6.0	V

● Block diagram

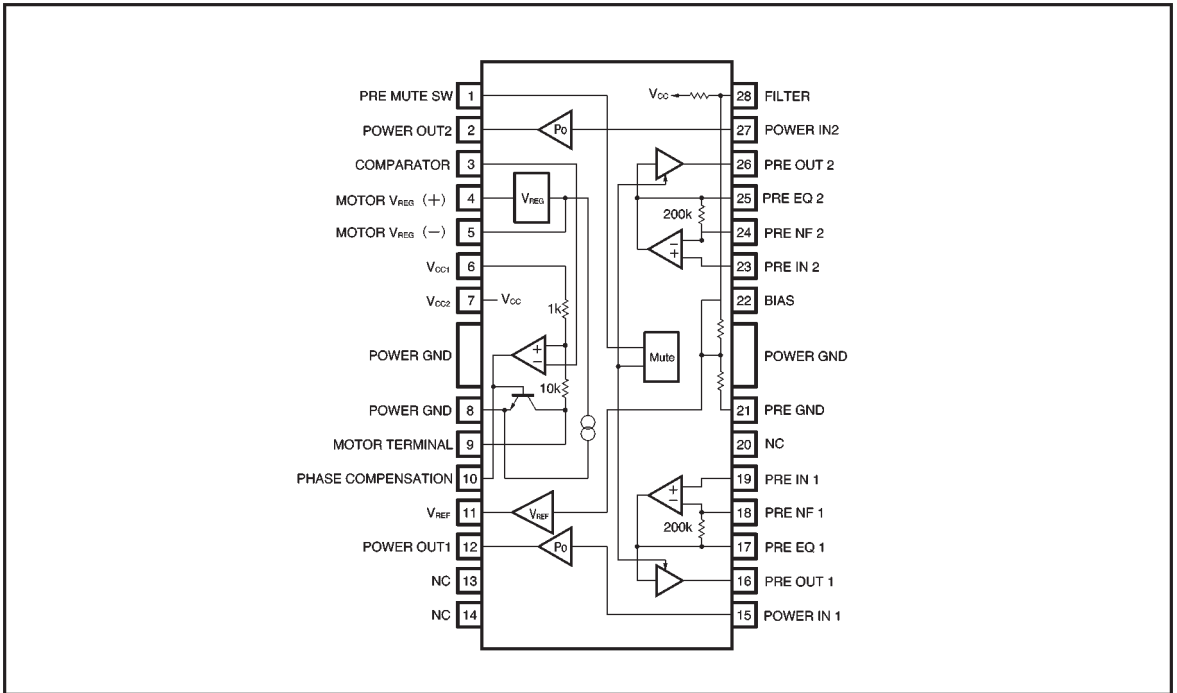

●Electrical characteristics (unless otherwise noted, Ta = 25°C, Vcc = 3V, and f = 1kHz)

BA3528AFP

Parameter	Symbol	Min.	Typ.	Max.	Unit	Conditions
Quiescent current	I _Q	—	11	18	mA	V _{IN} =0V _{rms}
Channel separation	CS L-R	30	40	—	dB	R _g =2.2kΩ, R _L =32Ω
(Preamplifier)						R _L =10kΩ
Open loop voltage gain	G _{VO}	72	80	—	dB	V _O =200mV _{rms}
Closed loop voltage gain	G _{VC1}	33	36	39	dB	V _O =100mV _{rms}
Maximum output voltage	V _{OM}	350	500	—	mV _{rms}	THD=1%
Total harmonic distortion	THD1	—	0.03	0.2	%	V _O =200mV _{rms}
Input conversion noise voltage	V _{NIN}	—	1.0	1.8	μV _{rms}	R _g =2.2kΩ, BPF=20~20kHz
Ripple rejection ratio	RR1	43	53	—	dB	f _{RR} =100Hz, V _{RR} =-20dBm
Input bias current	I _B	—	365	850	nA	V _{IN} =0V _{rms}
Mute level	MUTE	—	80	—	dB	
(Power amplifier)						R _L =32Ω (excluding P _{OUT1})
Rated output 1	P _{OUT1}	25	34	—	mW/ch	R _L =16Ω, THD=10%
Rated output 2	P _{OUT2}	14.5	20	—	mW/ch	R _L =32Ω, THD=10%
Total harmonic distortion	THD 2	—	0.2	1.0	%	P _O =1mW
Output noise voltage	V _{NO}	—	65	100	μV _{rms}	BPF=20~20kHz
Ripple rejection ratio	RR2	53	61	—	dB	f _{RR} =100Hz, V _{RR} =-20dBm
Closed loop voltage gain	G _{VC2}	33	36	39	dB	V _O =300mV _{rms}
Input resistance	R _{IN}	13	18	23	kΩ	
(Motor controller)						
Quiescent current	I _Q	—	2	3.5	mA	
Reference voltage	V _{REG}	1.16	1.23	1.31	V	Voltage between pins 4 and 5 (R _{s4} ≥20kΩ)
Saturation voltage	V _{SAT}	—	0.2	0.6	V	V _{CC} =1.8V, R _a =4.7Ω
Voltage characteristic 1	$\frac{\Delta V_{REG}}{V_{REG}} / V_{CC}$	-1.25	0.1	1.25	% / V	V _{CC} =1.8V~6V
Voltage characteristic 2	$\frac{\Delta V_a}{V_a} / V_{CC}$	-1.2	0.1	1.2	% / V	V _{CC} =1.8V~6V
Current characteristic	$\frac{\Delta V_{REG}}{V_{REG}} / I_g$	-0.2	0.01	0.2	% / A	I _g =1mA~20mA
Temperature characteristic	$\frac{\Delta V_{REG}}{V_{REG}} / T_a$	—	0.01	—	% / °C	T _a =-25~+75°C

BA3529AFP

Parameter	Symbol	Min.	Typ.	Max.	Unit	Conditions
Quiescent current	I_Q	—	11	18	mA	$V_{IN}=0V_{rms}$
Channel separation	CS L-R	35	45	—	dB	$R_g=2.2k\Omega$, $R_L=32\Omega$
〈Preamplifier〉						$R_L=10k\Omega$
Open loop voltage gain	G_{VO}	72	80	—	dB	$V_o=200mV_{rms}$
Closed loop voltage gain	G_{VC1}	33	36	39	dB	$V_o=100mV_{rms}$
Maximum output voltage	V_{OM}	350	500	—	mV_{rms}	THD=1%
Total harmonic distortion	THD1	—	0.03	0.2	%	$V_o=200mV_{rms}$
Input conversion noise voltage	V_{NIN}	—	1.0	1.8	μV_{rms}	$R_g=2.2k\Omega$, BPF=20~20kHz
Ripple rejection ratio	RR1	43	53	—	dB	$f_{RR}=100Hz$, $V_{RR}=-20dBm$
Input bias current	I_B	—	365	850	nA	$V_{IN}=0V_{rms}$
Mute level	MUTE	—	80	—	dB	
〈Power amplifier〉						$R_L=32\Omega$ (excluding P_{OUT1})
Rated output 1	P_{OUT1}	25	34	—	mW/ch	$R_L=16\Omega$, THD=10%
Rated output 2	P_{OUT2}	14.5	20	—	mW/ch	$R_L=32\Omega$, THD=10%
Total harmonic distortion	THD 2	—	0.1	0.9	%	$P_o=1mW$
Output noise voltage	V_{NO}	—	26	50	μV_{rms}	BPF=20~20kHz
Ripple rejection ratio	RR2	61	69	—	dB	$f_{RR}=100Hz$, $V_{RR}=-20dBm$
Closed loop voltage gain	G_{VC2}	25	27	29	dB	$V_{IN}=300V_{rms}$
Input resistance	R_{IN}	13	18	23	k Ω	
〈Motor controller〉						
Quiescent current	I_Q	—	2	3.5	mA	
Reference voltage	V_{REG}	1.16	1.23	1.31	V	Voltage between pins 4 and 5 ($R_{6-4}\geq 20k\Omega$)
Saturation voltage	V_{SAT}	—	0.2	0.6	V	$V_{CC}=1.8V$, $R_a=4.7\Omega$
Voltage characteristic 1	$\frac{\Delta V_{REG}}{V_{REG}} / V_{CC}$	-1.25	0.1	1.25	% / V	$V_{CC}=1.8V\sim 6V$
Voltage characteristic 2	$\frac{\Delta V_a}{V_a} / V_{CC}$	-1.2	0.1	1.2	% / V	$V_{CC}=1.8V\sim 6V$
Current characteristic	$\frac{\Delta V_{REG}}{V_{REG}} / I_B$	-0.2	0.01	0.2	% / A	$I_B=1mA\sim 20mA$
Temperature characteristic	$\frac{\Delta V_{REG}}{V_{REG}} / T_a$	—	0.01	—	% / $^{\circ}C$	$T_a=-25\sim +75^{\circ}C$

● Measurement circuit

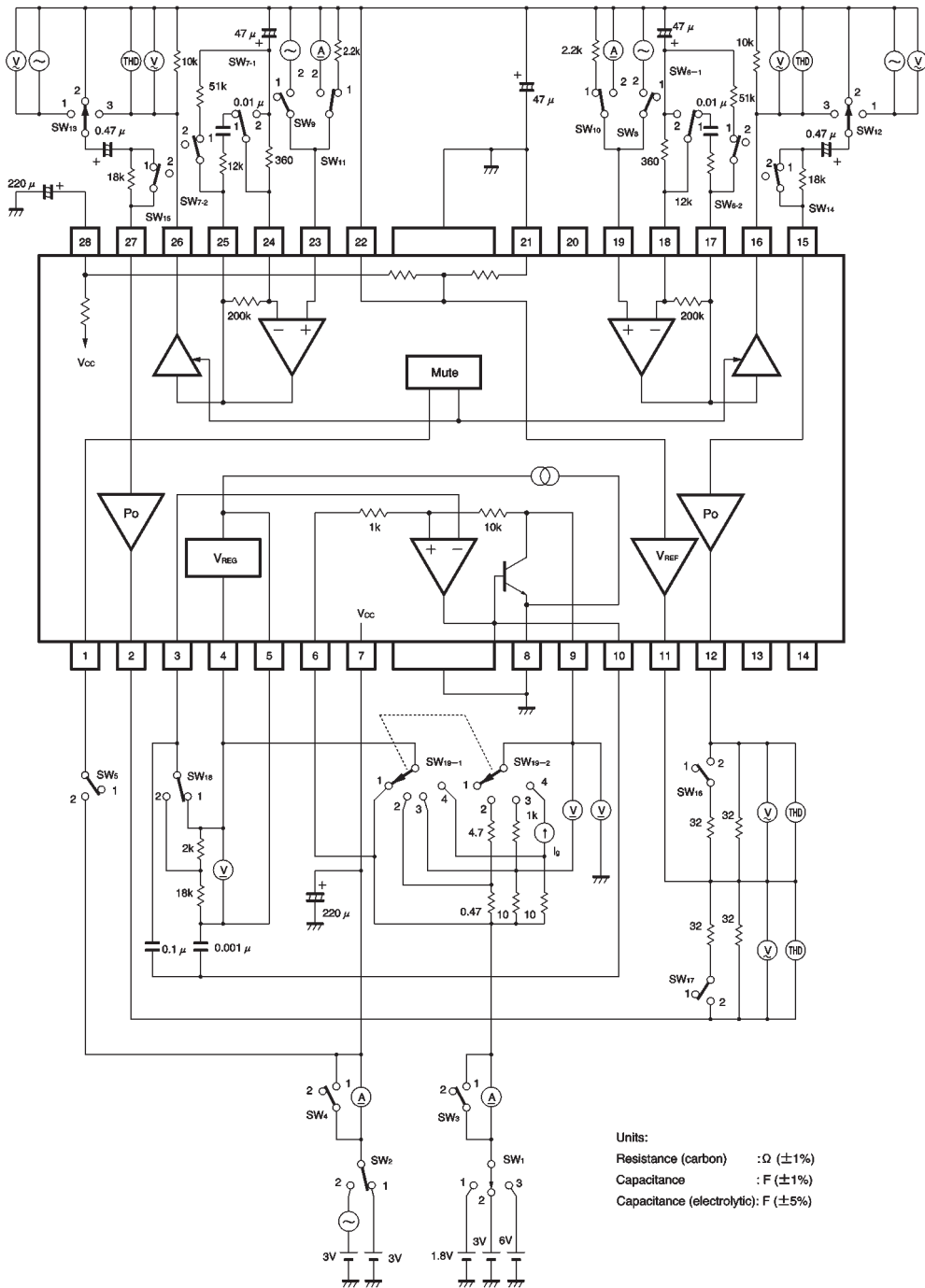

Fig. 1

● Circuit operation

(1) Preamplifier

In the preamplifier input stage the pin 22 bias is the input and the negative feedback virtual earth, and the bias for the input stage transistor is taken from pin 22 via the tape head to allow direct coupling. Connect a 1000pF capacitor in parallel with the tape head to prevent high-frequency interference (see Fig. 2).

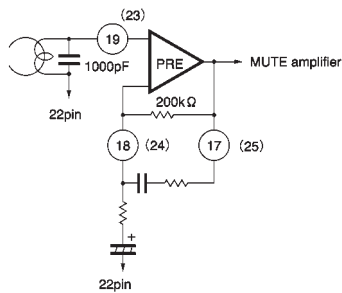

Fig. 2

(2) Mute amplifier

Preamplifier output muting can be switched on and off. The mute is off when the mute switch input (pin 1) is low or open, and on when the mute switch input is high (tied to V_{CC} via a resistor), see Fig. 3.

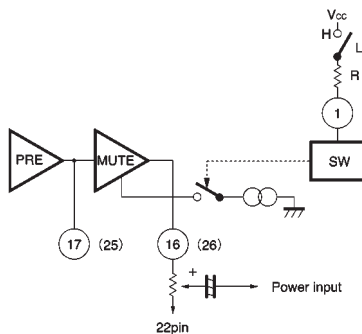

Fig. 3

(3) Equalizer

The preamplifier is based on an NAB120 μ s NF-type equalizer. It is possible to add a switching function for the equalizer using the mute amplifier. Switching of the equalizer constant is controlled by the voltage on pin 1 (low or high). Note, however, when this is done, preamplifier muting no longer operates (see Fig. 4).

(4) Power amplifier

The power amplifier employs an NF circuit with fixed gain. $G_{VC} = 36\text{dB}$ (BA3528AFP) and $G_{VC} = 27\text{dB}$ (BA3529AFP).

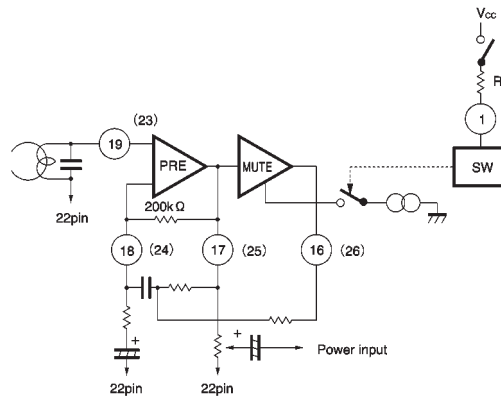

Fig. 4

For the input stage, the pin 22 bias point is the input and the negative feedback virtual earth point, and the first stage transistor bias is taken from pin 22. The built-in V_{REF} amplifier uses the same bias point as its input, and its output voltage is about the same as DC output voltage from the power amplifier. This becomes the virtual earth for the headphones (see Fig. 5).

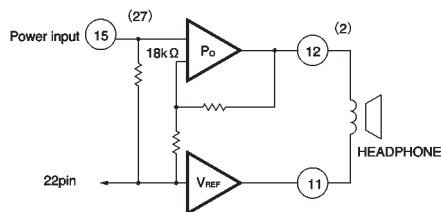

Fig. 5

(5) Motor controller circuit

The motor controller circuit uses a resistance bridge to maintain uniform motor speed regardless of changes in supply voltage, ambient temperature and load torque. Speed control is performed by a comparator and a stable on-chip reference voltage ($V_{REG} = 1.23V$). See Fig. 6.

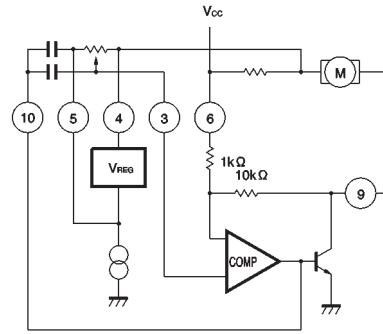
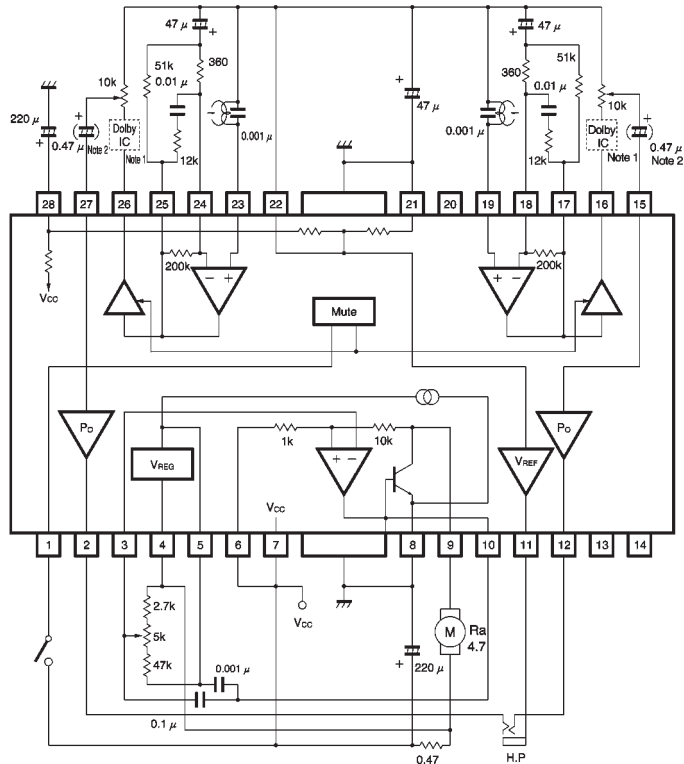

Fig. 6

● Application examples



Units
 Resistors : Ω (±5%)
 Capacitors : F (±10%)
 Capacitors (electrolytic): F (±20%)

Note 1:
 For Dolby use (BA3529AFP only).
 Note 2:
 Coupling capacitors not required.

Fig. 7 Headphone stereo with pre-mute

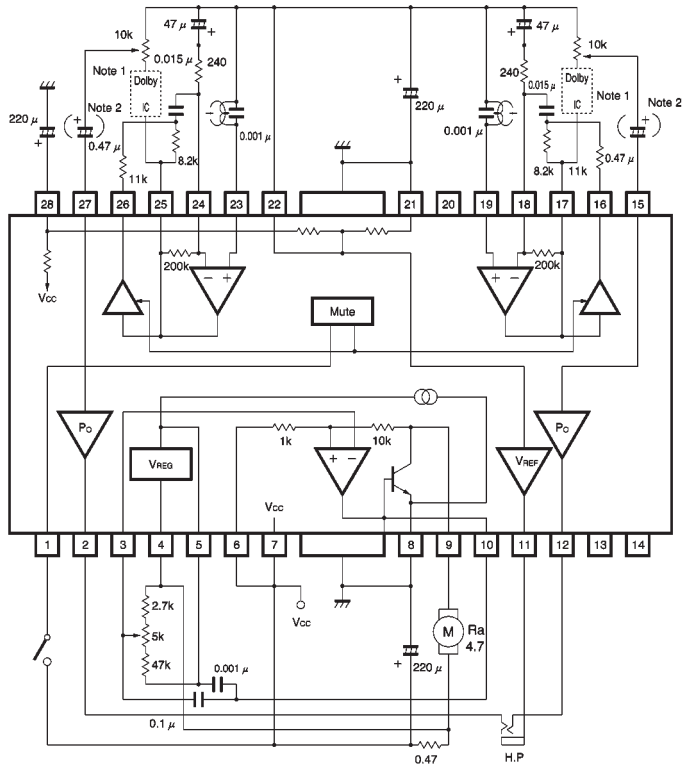

Units
 Resistors : Ω ($\pm 5\%$)
 Capacitors : F ($\pm 10\%$)
 Capacitors (electrolytic): F ($\pm 20\%$)

Note 1:
 For Dolby use (BA3529AFP only).
 Note 2:
 Coupling capacitors not required.

Fig. 8 Headphone stereo metal / normal switch

● Attached components

(1) Preamplifier

If the closed-loop voltage gain (G_{VC}) of the preamplifier is below 30dB for a frequency of $f = 1\text{ kHz}$, oscillation may occur.

(2) Playback equalizer terminal (NAB)

The playback equalizer characteristics are determined by the RC circuit connected between the output and NF pins.

For the circuit in Fig. 9, with a closed-loop voltage gain of G_{VC} at an input frequency of 1 kHz, the relationships between the values of the RC circuit components are as follows:

$$C_1 = \frac{3180 \times 10^{-6}}{R_1 + 200 + 10^3}$$

$$R_2 = 2 \times R_1 \times 10^{-G_{VC}/20}$$

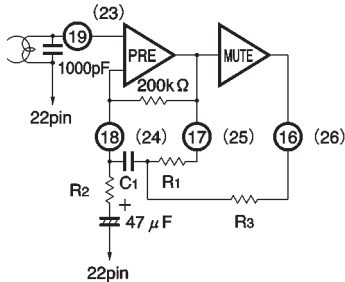

Fig. 9

The equalizer can be switched on and off using the mute amplifier. If equalization for metal tape is added, determine R_3 as follows:

$$R_3 = 1.4 \times R_1$$

(3) Pre-mute switching noise

If you use the mute amplifier for pre-muting,

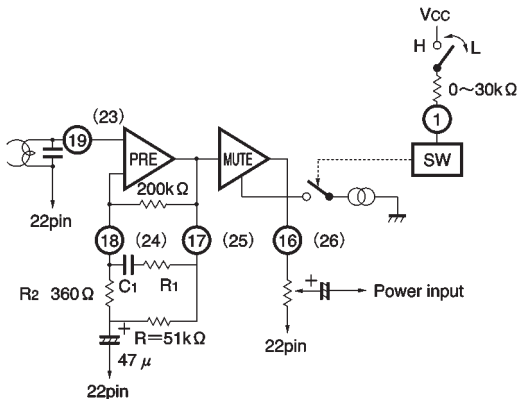

Fig. 10

the voltage difference between the pre-output and pin 22 will generate switching noise (a "pop" sound) when the mute is switched on and off. To reduce the DC gain and reduce this switching noise, we recommend that you connect a resistor ($R = 51\text{ k}\Omega$) as shown in Fig. 10. This resistor reduces the gain of the circuit in the bass region of the playback equalizer as shown in the graph in Fig. 11. By using different combinations of component values for R_1 and C_1 , it is possible to compensate for this effect in the low-frequency region as shown in the graph in Fig. 12.

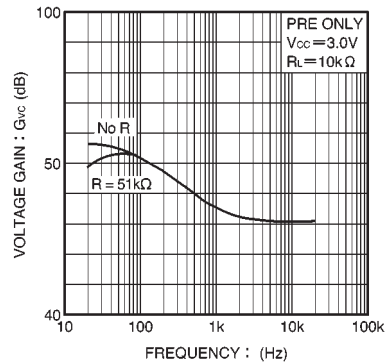

Fig. 11

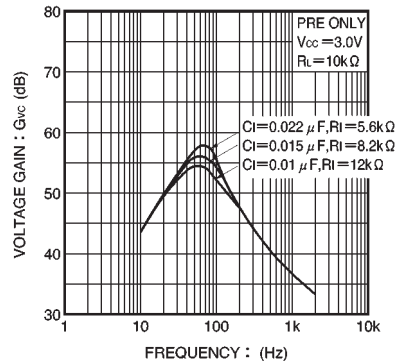

Fig. 12

(4) Mute amplifier output

To switch the mute amplifier on and off, switch the constant-current supply for the mute amplifier off and on by switching the voltage on pin 1 (Pre-mute SW) high or low. When the mute is switched on, the mute amplifier output goes open circuit and the output voltage is unstable resulting in the generation of an audible “pop” sound. To prevent this, bias pin 22 through the volume control as shown in Fig. 13.

In applications that use a directly connected output coupling capacitor, connect a resistor as shown in the circuit diagram in Fig. 14 to reduce the pre-mute switching noise described in (3) above.

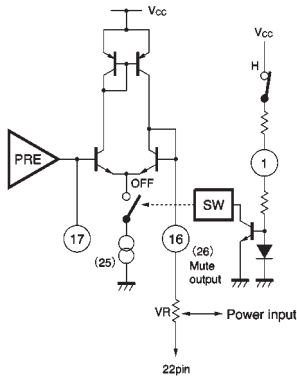

Fig. 13

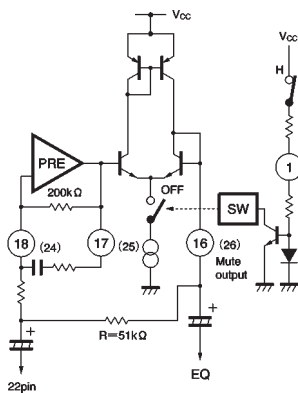

Fig. 14

(5) Preventing oscillation

Connect a capacitor of approximately 1000pF between the preamplifier input and pin 22 to prevent oscillation, and as a countermeasure against strong electric fields. This capacitor can also be used for treble-region compensation. In this case, decide on a value for it based on the relationship with the impedance of the magnetic head (see Fig. 15).

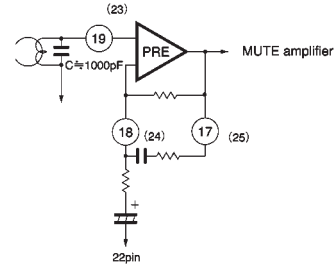

Fig. 15

When countermeasures against strong electric fields for the power amplifiers are required, connect bypass capacitors between each input pin and pin 22, and connect choke coils in series with the output pins and the headphones. The component values should be about 330pF for the bypass capacitors, and the 10μH for the choke coils so that they do not effect the audible frequency range.

Another effective measure is to connect a bypass capacitor of about 1000pF in parallel with the filter capacitor between pin 22 and ground (pin 21). Refer to the circuit diagram in Fig. 16.

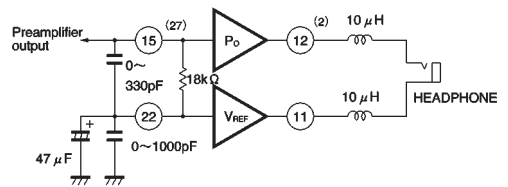

Fig. 16

(6) Motor speed setting

To control the motor speed, the stable built-in reference voltage V_{REG} is divided across R_4 and R_5 , and this voltage is used as the speed control voltage. The balance conditions for the bridge circuit are as follows:

$$E_a = \left(R_1 \times \frac{R_2}{R_3} - R_a \right) I_a + \left(1 + \frac{R_2}{R_3} \right) \left(\frac{R_5}{R_4 + R_5} \right) V_{REG}$$

(however, $I_r \ll I_a$)

From this, the balance conditions for the load fluctuation zero are:

$$R_a = 10 \times R_1$$

$$E_a = 11 \times \frac{R_5}{R_4 + R_5} V_{REG}$$

● Operation notes

(1) Application circuits

Provided the recommended circuit constants are used, the application circuits should function correctly. However, we recommend that you confirm the characteristics of the circuits in actual use. If you change the circuit constants, check both the static and transient characteristics of the circuit, and allow sufficient margin to accommodate variations between both ICs and external components.

(2) Recommended supply voltage

The values given in the electrical characteristics table are guaranteed only for $T_a = 25^\circ\text{C}$, and $V_{CC} = 3\text{V}$. However, as long as the IC is operated within the recommended operating temperature and supply voltage ranges, the general circuit functions are guaranteed to operate correctly, and there will not be significant changes in the electrical characteristics.

However, if $R_a < 10 \times R_1$, the amount of positive feedback increases, and the circuit will be unstable, so within the operating temperature range, always make

$$R_a \geq 10 \times R_1 \text{ (see Fig. 17).}$$

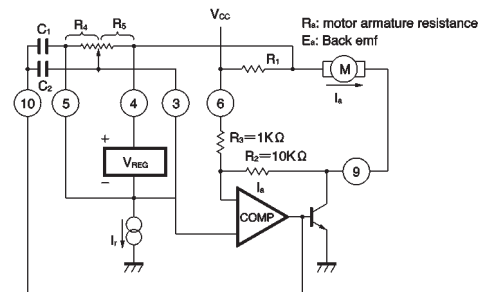

C1 and C2: capacitors to prevent oscillation

Fig. 17

(3) Power dissipation

The internal power dissipation of the IC depends strongly on the value of the load resistance and the supply voltage.

For this reason, when designing sets for mass production, pay due consideration to the power dissipation characteristics of the IC with respect to ambient temperature and supply voltage (see Figs. 18 and 19). Note, that the maximum allowed power dissipation is 1.7W at 25°C , and this decreases by 13.6mW for each increase in temperature of 1°C over this.

(4) PCB layout

In certain cases, the external circuit wiring can induce oscillations in the IC or degrade circuit performance. To avoid this, design the PCB wiring in such a way as to keep external wiring as short as possible, and ensure that it does not have common impedance.

● Electrical characteristic curves

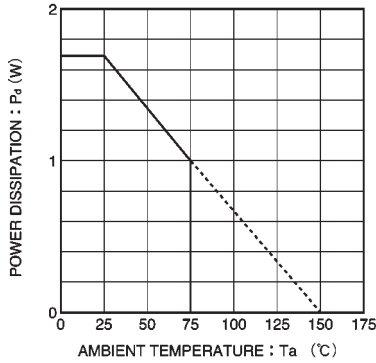

Fig. 18 Power dissipation vs. ambient temperature

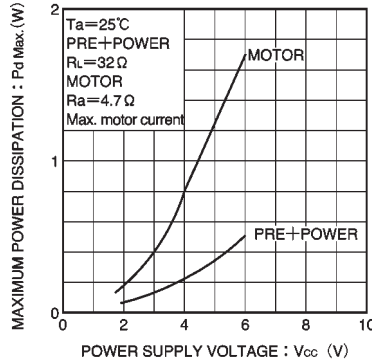

Fig. 19 Maximum power dissipation vs. power supply voltage

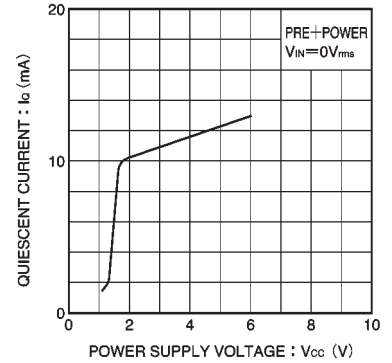

Fig. 20 Quiescent current vs. power supply voltage

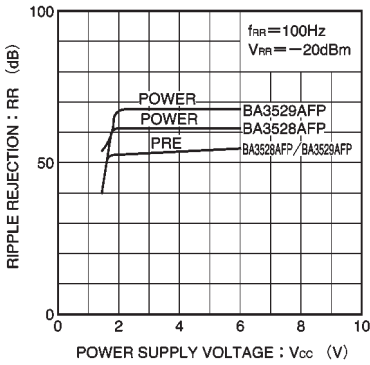

Fig. 21 Ripple rejection ratio vs. power supply voltage

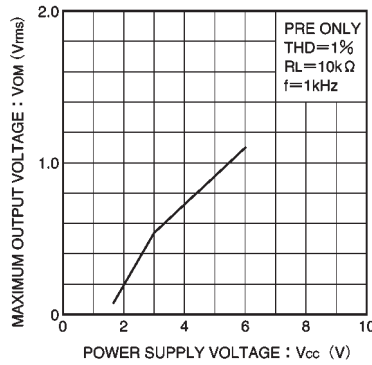

Fig. 22 Maximum output voltage vs. power supply voltage

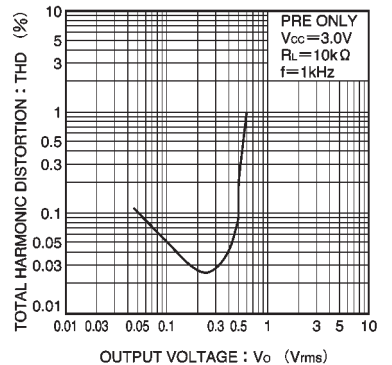

Fig. 23 Total harmonic distortion vs. output voltage

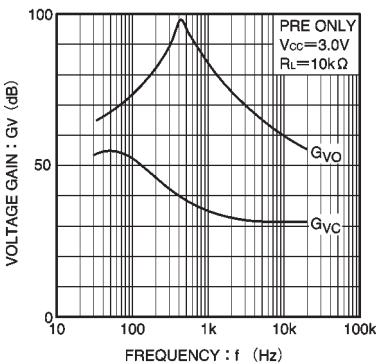

Fig. 24 Voltage gain vs. frequency

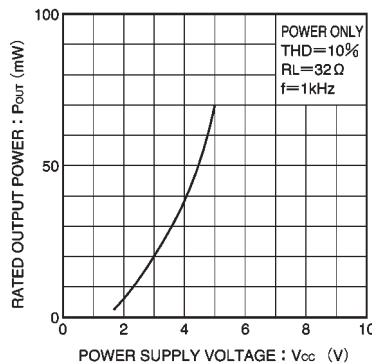

Fig. 25 Rated output power vs. power supply voltage

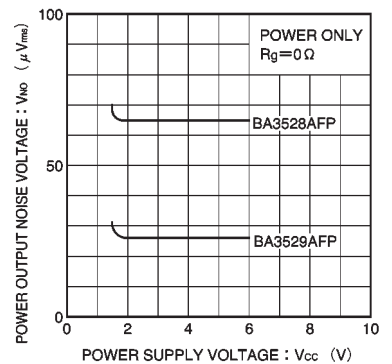

Fig. 26 Output noise voltage vs. power supply voltage

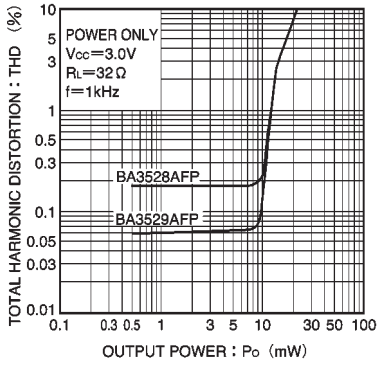

Fig. 27 Total harmonic distortion vs. output voltage

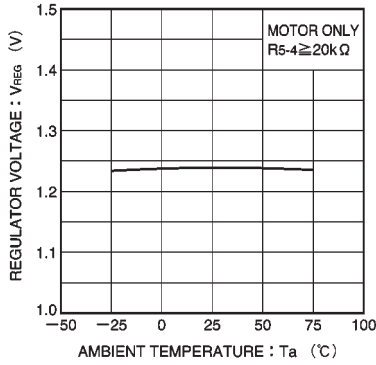

Fig. 28 Regulator voltage vs. ambient temperature

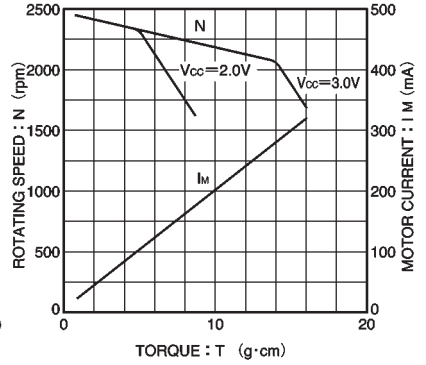
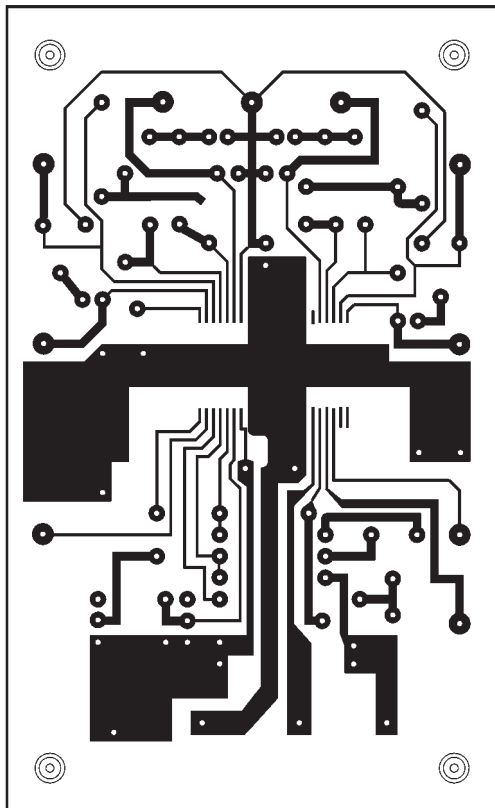

Fig. 29 Rotation speed and motor current vs. torque

●Application board patterns



PCB thickness: 1.6mm
Copper thickness: 35 μm
Copper side

●Application board component layout

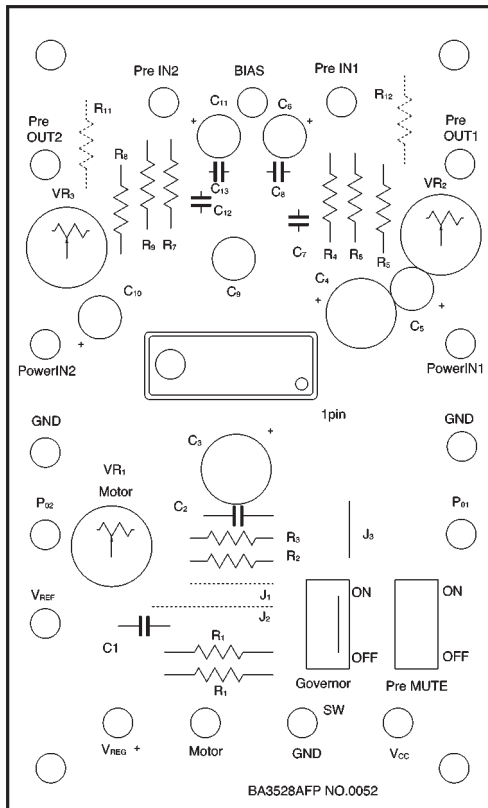

Silk side

● External dimensions (Units: mm)

