

STRAIGHT PCB RECEPTACLE EDGE CARD – PIN IN PASTE VERSION



R197.160._40

TECHNICAL DATA SHEET

Rev	Date	Edited	Approved	Validated	Modification
1	05/10/2020	T.Mbuyi	C.Chavanne	Y.Gay	Creation

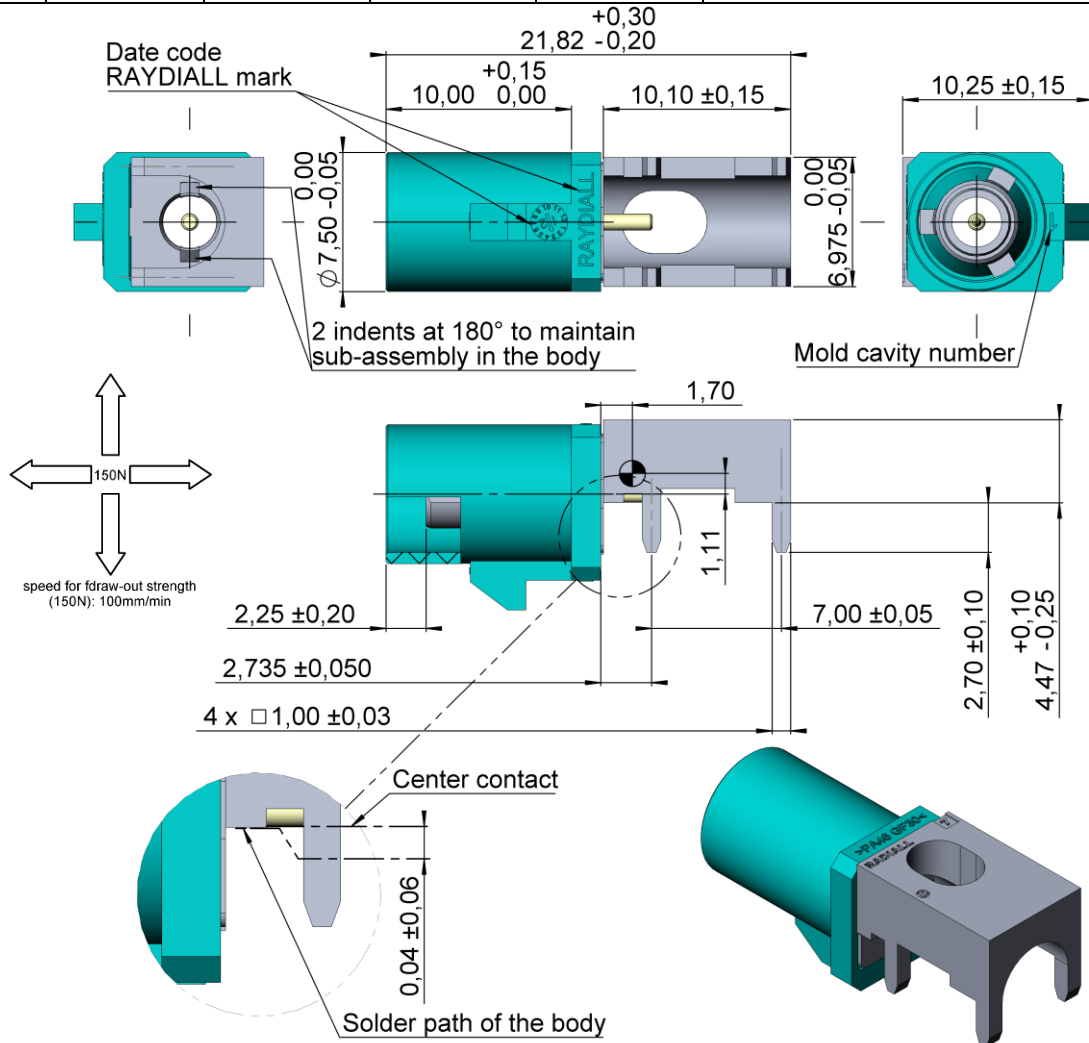

All dimensions are in mm

Components	Materials	Plating
Body	Zinc Alloy	Tin for high temperature
Center contact	Brass	Gold over Nickel
Insulator	PTFE	Natural color
Housing	Polymer PA 4.6 GF30*	See Codings

*Material classification flammability UL94: HB

STRAIGHT PCB RECEPTACLE
EDGE CARD – PIN IN PASTE VERSION



R197.160._40

TECHNICAL DATA SHEET

Interface According to ISO 20860-1

Application This terminal has been qualified according USCAR-17 Rev.4 (March 2013) and USCAR-2 Rev.5 (November 2007).

Electrical characteristics

Impedance	50 Ω
Frequency	0-4 GHz
VSWR	1.6* + 0.013 xF(GHz) Maxi
Voltage rating	335 Veff Maxi
Dielectric withstanding Voltage	1000 Veff maxi
Insulation resistance	1000 MΩ

*Coax transmission line only

Mechanical characteristics

Center contact retention, axial force, mating end	≥10 N
Center contact retention, axial force, opposite end	≥10 N
Housing retention	≥110 N
Mating cycles	≥ 50

Environmental

Operating temperature	-40 / +110°C
RoHS compliant	

Component weight 2.23 g

Codings To obtain the complete part number, please fill in the blank “_” with the coding letter



A
Black
9005



B
Crème White
9001



C
Blue
5005



D
Bordeaux
4004



E
Green
6002



F
Brown
8011



G
Grey
7031

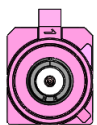

H
Violet
4003

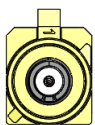

I
Beige
1001

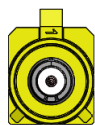

K
Curry
1027



L
Carmin
3002



M
Pastel Orange
2003



N
Pastel Green
6019



Z
Water blue
5021

STRAIGHT PCB RECEPTACLE EDGE CARD – PIN IN PASTE VERSION

R197.160._40

TECHNICAL DATA SHEET

Packaging 2 plastic reels inside 1 cardboard box

Primary packaging: plastic reel

- Dimensions : Ø 330 x 48mm
- Number of connectors per reel: 350
- Carrier tape description:
 - 44mm width, 16mm pitch.
 - Material: thermoplastic static dissipative. Cover tape material: Thermoplastic antistatic

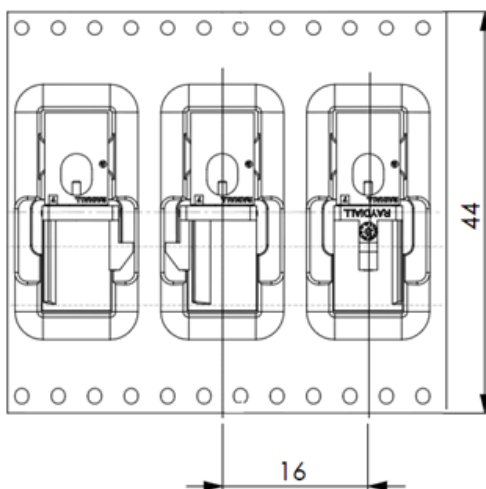
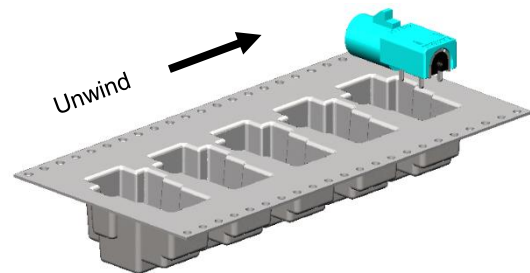
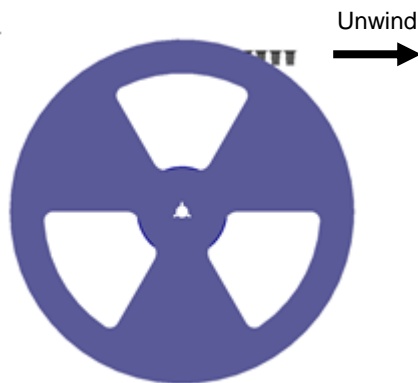

(Picture is not contractual)

Secondary packaging: Cardboard box

- Outside dimensions: 380x380x130 mm
- Number of reels per cardboard box: 2
- Number of connectors per cardboard box: 700
- Weight: 2.3 kg



(Picture is not contractual)

Third Packaging: Pallet

- PALLET Europe 1200 x 800mm
- Height: < 1100 mm
- 42 cardbox by pallet
- 29400 receptacles by complete pallet

STRAIGHT PCB RECEPTACLE EDGE CARD – PIN IN PASTE VERSION

R197.160._40

TECHNICAL DATA SHEET

Storage

The product must be used as soon as it is removed from the cells.

Do not leave the product in the open air.

Reels should be stored indoors, in his original unopened packaging, in a controlled climate environment not exceeding -20°C / +40°C and 60% Max. relative humidity.

Reels should be protected from direct sunlight and should be used on a "first-in, first-out" basis.

It is recommended that connector be used within 1 year from the date of manufacture when stored according to the recommended storage condition.

PCB Cut out

- PCB Thickness: 1,6 mm.
- PCB recommended material: FR4 ($\epsilon_r = 4.6$).
- 5 metalized holes.
- Solder paste has to be printed onto the land of solder and into holes to permit Pin In Hole Reflow.
- This layout is a recommendation for solderability.
- Design and performances of the PCB will depend on customers choices and RAYDIALL cannot be considered as responsible in case of bad performances.
- A numerical simulation of the PCB is recommended to optimize the RF performance in high frequency.

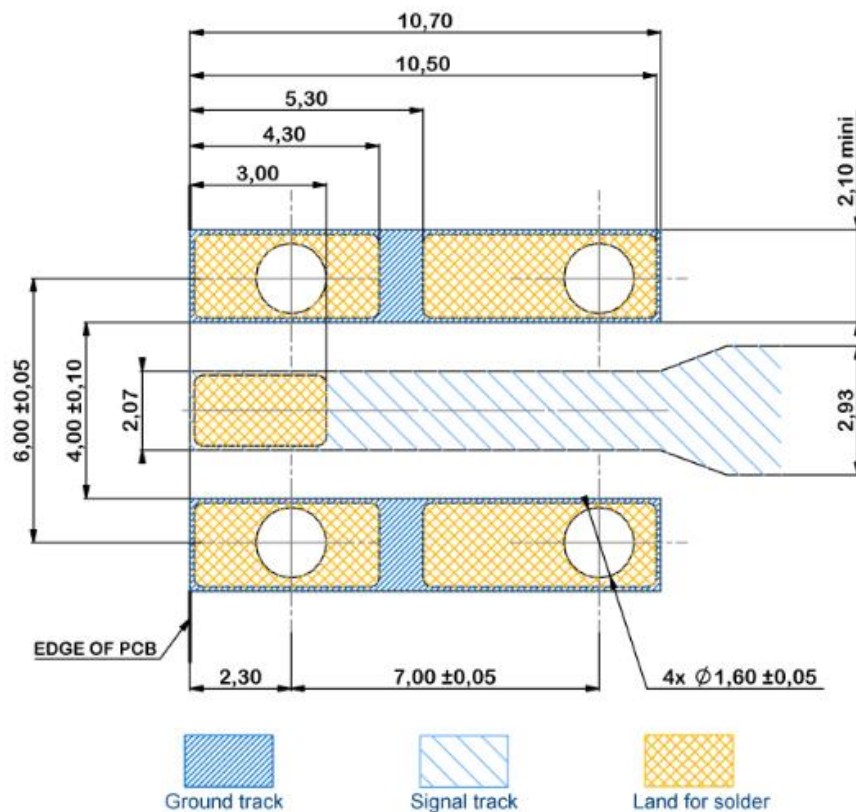

STRAIGHT PCB RECEPTACLE EDGE CARD – PIN IN PASTE VERSION



R197.160._40

TECHNICAL DATA SHEET

Solder procedure

1. Deposit solder paste "Sn95.5Ag3.8Cu0.7" on mounting zone by screen printing application.
We recommend a low Residue Solid Flux.
We advise a thickness of 0,2 millimeters min. (0,008 inch min.).
The holes must be totally filled with cream Verify that the edges of the zone are clean.
2. Placement of the receptacle on the mounting zone with an automatic machine of "pick and place" type.
Video camera is preferred to check the positioning of the component.
Adhesive agents are forbidden on the receptacle.
3. Soldering (typical profile to use is given below).
4. Clean printed circuit boards.
5. Checking of solder joints and component position by visual inspection

Temperature profile

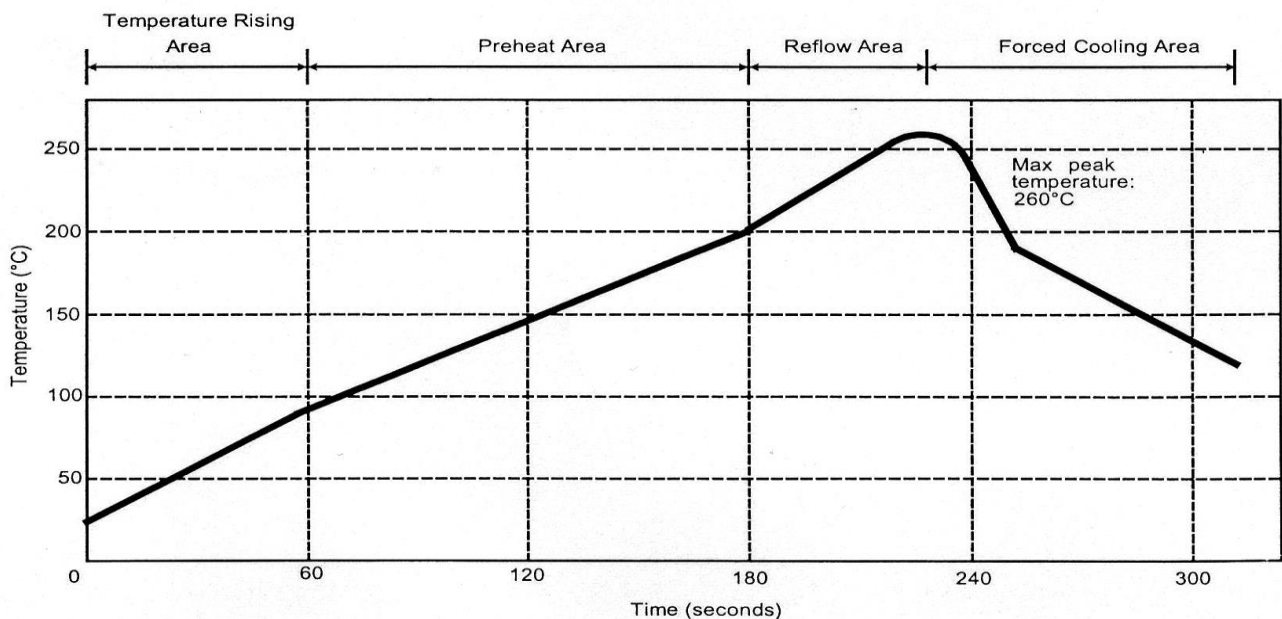

Parameter	Value	Unit
Temperature rising Area	1 - 4	°C/sec
Max Peak Temperature	260	°C
Max dwell time @260°C	10	sec
Min dwell time @235°C	20	sec
Max dwell time @235°C	60	sec
Temperature drop in cooling Area	-1 to - 4	°C/sec
Max dwell time above 100°C	420	sec

Mouser Electronics

Authorized Distributor

Click to View Pricing, Inventory, Delivery & Lifecycle Information:

[Raydiall Automotive:](#)

[R197.160.C40](#)