

PROFIBUS-Compatible Isolated RS-485 Interface

Functional Diagram

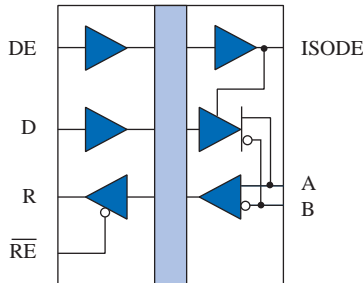

IL3685

| V _{ID} (A-B) | DE | \overline{RE} | R | D | Mode |
|-----------------------|----|-----------------|---|---|---------|
| ≥ 200 mV | L | L | H | X | Receive |
| ≤ -200 mV | L | L | L | X | Receive |
| ≥ 1.5 V | H | L | H | H | Drive |
| ≤ -1.5 V | H | L | L | L | Drive |
| X | X | H | Z | X | Hi-Z R |
| Open | L | L | H | X | Receive |

Features

- 3.3 / 5 V Input Supply Compatible
- 2500 V_{RMS} Isolation (1 minute)
- 20 ns Propagation Delay
- 40 Mbps Data Rate
- 5 ns Pulse Skew
- 20 kV/ μ s Transient Immunity
- Thermal Shutdown Protection
- -40°C to $+85^{\circ}\text{C}$ Temperature Range
- Meets or Exceeds ANSI RS-485 and ISO 8482:1987(E)
- PROFIBUS Compliant
- 16-pin SOIC Package
- UL1577 Approval
- IEC 61010-2001 Approval

Applications

- Security Networks
- PROFIBUS DP and FMS Networks
- Building Environmental Controls
- Industrial Control Networks
- Gaming Systems
- Factory Automation

Description

The IL3685 is a galvanically isolated, high-speed differential bus transceiver, designed for bidirectional data communication on balanced transmission lines. The device uses NVE's patented* IsoLoop spintronic Giant Magnetoresistance (GMR) technology.

The IL3685 is fully PROFIBUS compliant, including the rigorous PROFIBUS differential output voltage specifications.

The device is compatible with 3.3 V as well as 5 V input supplies, allowing interface to standard microcontrollers without additional level shifting.

Current limiting and thermal shutdown features protect against output short circuits and bus contention that may cause excessive power dissipation. Receiver inputs feature a "fail-safe if open" design, ensuring a logic high R-output if A/B are floating.



Absolute Maximum Ratings⁽¹⁾

| Parameters | Symbol | Min. | Typ. | Max. | Units | Test Conditions |
|----------------------------------|--------------------|------|------|----------------|-------|-----------------|
| Storage Temperature | T_S | -65 | | 150 | °C | |
| Ambient Operating Temperature | T_A | -40 | | 100 | °C | |
| Voltage Range at A or B Bus Pins | | -7 | | 12 | V | |
| Supply Voltage ⁽¹⁾ | V_{DD1}, V_{DD2} | -0.5 | | 7 | V | |
| Digital Input Voltage | | -0.5 | | $V_{DD} + 0.5$ | V | |
| Digital Output Voltage | | -0.5 | | $V_{DD} + 1$ | V | |

Recommended Operating Conditions

| Parameters | Symbol | Min. | Typ. | Max. | Units | Test Conditions |
|---|------------------------|------------|------|------------|-------|--|
| Supply Voltage | V_{DD1} V_{DD2} | 3.0 4.5 | | 5.5 5.5 | V | |
| Input Voltage at any Bus Terminal (separately or common mode) | V_I V_{IC} | | | 12 -7 | V | |
| High-Level Digital Input Voltage | V_{IH} | 2.4 3.0 | | V_{DD1} | V | $V_{DD1} = 3.3\text{ V}$ $V_{DD1} = 5.0\text{ V}$ |
| Low-Level Digital Input Voltage | V_{IL} | 0 | | 0.8 | V | |
| Differential Input Voltage ⁽²⁾ | V_{ID} | | | +12 / -7 | V | |
| High-Level Output Current (Driver) | I_{OH} | | | 60 | mA | |
| High-Level Digital Output Current (Receiver) | I_{OH} | | | 8 | mA | |
| Low-Level Output Current (Driver) | I_{OL} | -60 | | | mA | |
| Low-Level Digital Output Current (Receiver) | I_{OL} | -8 | | | mA | |
| Ambient Operating Temperature | T_A | -40 | | 85 | °C | |
| Digital Input Signal Rise and Fall Times | t_{IR}, t_{IF} | DC Stable | | | | |

Insulation Specifications

| Parameters | Symbol | Min. | Typ. | Max. | Units | Test Conditions |
|------------------------------|--------|------|-------------------------|------|------------------------------|-----------------------|
| Creepage Distance (external) | | 8.08 | | | mm | |
| Barrier Impedance | | | $> 10^{14} \parallel 7$ | | $\Omega \parallel \text{pF}$ | |
| Leakage Current | | | 0.2 | | μA_{RMS} | 240 V_{RMS} , 60 Hz |

Safety and Approvals

IEC61010-2001 (pending)

TUV Certificate Numbers: N1502812, N1502812-101

Classification: Reinforced Insulation

| Model | Package | Pollution Degree | Material Group | Max. Working Voltage |
|--------|-------------|------------------|----------------|----------------------|
| IL3685 | SOIC (0.3") | II | III | 300 V_{RMS} |

UL 1577 (pending)

Component Recognition Program File Number: E207481
Rated 2500 V_{RMS} for 1 minute

Soldering Profile

Per JEDEC J-STD-020C, MSL=2

Electrostatic Discharge Sensitivity

This product has been tested for electrostatic sensitivity to the limits stated in the specifications. However, NVE recommends that all integrated circuits be handled with appropriate care to avoid damage. Damage caused by inappropriate handling or storage could range from performance degradation to complete failure.

Pin Connections

| | | |
|----|------------------------|---|
| 1 | V _{DD1} | Input power supply |
| 2 | GND ₁ | Input power supply ground return (pin 2 is internally connected to pin 8) |
| 3 | R | Output data from bus |
| 4 | $\overline{\text{RE}}$ | Read data enable (if $\overline{\text{RE}}$ is high, R= high impedance) |
| 5 | DE | Drive enable |
| 6 | D | Data input to bus |
| 7 | NC | No internal connection |
| 8 | GND ₁ | Input power supply ground return (pin 8 is internally connected to pin 2) |
| 9 | GND ₂ | Output power supply ground return (pin 9 is internally connected to pin 15) |
| 10 | ISODE | Isolated DE output for use in PROFIBUS applications where the state of the isolated drive enable node needs to be monitored |
| 11 | NC | No internal connection |
| 12 | A | Non-inverting bus line |
| 13 | B | Inverting bus line |
| 14 | NC | No internal connection |
| 15 | GND ₂ | Output power supply ground return (pin 15 is internally connected to pin 9) |
| 16 | V _{DD2} | Output power supply |

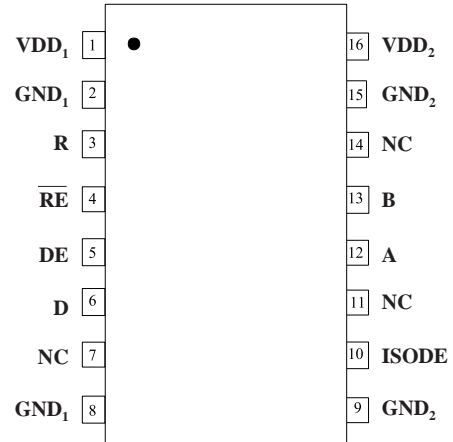

Driver Section

Electrical Specifications are T_{min} to T_{max} and $V_{DD} = 4.5\text{ V}$ to 5.5 V unless otherwise stated.

| Parameters | Symbol | Min. | Typ. ⁽⁵⁾ | Max. | Units | Test Conditions |
|---|--|------|---------------------|-----------|---------------|---|
| Output voltage | V_o | | | V_{DD} | V | $I_o = 0$ |
| Differential Output Voltage ⁽²⁾ | $ V_{OD1} $ | | | V_{DD} | V | $I_o = 0$ |
| Differential Output Voltage ⁽²⁾ | $ V_{OD2} $ | 2.1 | 3 | 3.5 | V | $R_L = 54\ \Omega$ |
| Differential Output Voltage ⁽²⁾⁽⁶⁾ | V_{OD3} | 1.9 | | 3.5 | V | $R_L = 60\ \Omega$ |
| Change in Magnitude of Differential Output Voltage ⁽⁷⁾ | $\Delta V_{OD} $ | | | ± 0.2 | V | $R_L = 54\ \Omega$ or $100\ \Omega$ |
| Common Mode Output Voltage | V_{OC} | | | 3 | V | $R_L = 54\ \Omega$ or $100\ \Omega$ |
| Change in Magnitude of Common Mode Output Voltage ⁽⁷⁾ | $\Delta V_{OC} $ | | | ± 0.2 | V | $R_L = 54\ \Omega$ or $100\ \Omega$ |
| Output Current ⁽⁴⁾ | I_o | | | 1 -0.8 | mA | Output Disabled, $V_o = 12$ $V_o = -7$ |
| High Level Input Current | I_{IH} | | | 10 | μA | $V_I = 3.5\text{ V}$ |
| Low Level Input Current | I_{IL} | | | -10 | μA | $V_I = 0.4\text{ V}$ |
| Absolute Short-circuit Output Current | I_{OS} | | | 250 | mA | $-7\text{ V} < V_o < 12\text{ V}$ |
| Supply Current | $V_{DD1} = +5\text{ V}$ $V_{DD1} = +3.3\text{ V}$ | | 4 3 | 6 4 | mA | No load (Outputs Enabled) |

Notes (apply to both driver and receiver sections):

- All Voltage values are with respect to network ground except differential I/O bus voltages.
- Differential input/output voltage is measured at the noninverting terminal A with respect to the inverting terminal B.
- Skew limit is the maximum propagation delay difference between any two devices at 25°C .
- The power-off measurement in ANSI Standard EIA/TIA-422-B applies to disabled outputs only and is not applied to combined inputs and outputs.
- All typical values are at $V_{DD1}, V_{DD2} = 5\text{ V}$ or $V_{DD1} = 3.3\text{ V}$ and $T_A = 25^\circ\text{C}$.
- $-7\text{ V} < V_{CM} < 12\text{ V}$; $4.5\text{ V} < V_{DD} < 5.5\text{ V}$.
- $\Delta|V_{OD}|$ and $\Delta|V_{OC}|$ are the changes in magnitude of V_{OD} and V_{OC} , respectively, that occur when the input is changed from one logic state to the other.
- This applies for both power on and power off, refer to ANSI standard RS-485 for exact condition. The EIA/TIA-422-B limit does not apply for a combined driver and receiver terminal.
- Includes 10 ns read enable time. Maximum propagation delay is 25 ns after read assertion.
- Pulse skew is defined as $|t_{PLH} - t_{PHL}|$ of each channel.
- Absolute Maximum specifications mean the device will not be damaged if operated under these conditions. It does not guarantee performance.

Receiver Section

Electrical Specifications are T_{min} to T_{max} and $V_{DD} = 4.5\text{ V}$ to 5.5 V unless otherwise stated.

| Parameters | Symbol | Min. | Typ. ⁽⁵⁾ | Max. | Units | Test Conditions |
|--|-----------|----------------|---------------------|---------|---------------|---|
| Positive-going Input Threshold Voltage | V_{IT+} | | | 0.2 | V | $-7\text{ V} < V_{CM} < 12\text{ V}$ |
| Negative-going Input Threshold Voltage | V_{IT-} | -0.2 | | | V | $-7\text{ V} < V_{CM} < 12\text{ V}$ |
| Hysteresis Voltage ($V_{IT+} - V_{IT-}$) | V_{HYS} | | 28 | | mV | $V_{CM} = 0\text{ V}$, $T = 25^\circ\text{C}$ |
| High Level Digital Output Voltage | V_{OH} | $V_{DD} - 0.2$ | V_{DD} | | V | $V_{ID} = 200\text{ mV}$ $I_{OH} = -20\text{ }\mu\text{A}$ |
| Low Level Digital Output Voltage | V_{OL} | | | 0.2 | V | $V_{ID} = -200\text{ mV}$ $I_{OH} = 20\text{ }\mu\text{A}$ |
| High-impedance-state output current | I_{OZ} | | | ± 1 | μA | $V_O = 0.4$ to $(V_{DD2} - 0.5)$ V |
| Line Input Current ⁽⁸⁾ | I_I | | | 1 | mA | $V_I = 12\text{ V}$ |
| | | | | -0.8 | mA | $V_I = -7\text{ V}$ |
| Input Resistance | R_I | 20 | | | k Ω | |
| Supply Current | I_{DD2} | | 5 | 8 | mA | No load (Outputs Enabled) |

Switching Characteristics

| $V_{DD1} = +5\text{ V}$, $V_{DD2} = +5\text{ V}$ | | | | | | |
|---|---------------|------|---------------------|------|-------|--|
| Parameters | Symbol | Min. | Typ. ⁽⁵⁾ | Max. | Units | Test Conditions |
| Data Rate | | 40 | | | Mbps | $R_L = 54\text{ }\Omega$, $C_L = 50\text{ pF}$ |
| Propagation Delay ^(2, 9) | t_{PD} | | 20 | 30 | ns | $V_O = -1.5$ to 1.5 V , $C_L = 15\text{ pF}$ |
| Pulse Skew ^(2, 10) | $t_{SK}(P)$ | | 1 | 5 | ns | $V_O = -1.5$ to 1.5 V , $C_L = 15\text{ pF}$ |
| Skew Limit ⁽³⁾ | $t_{SK}(LIM)$ | | 2 | 10 | ns | $R_L = 54\text{ }\Omega$, $C_L = 50\text{ pF}$ |
| Output Enable Time To High Level | t_{PZH} | | 15 | 30 | ns | $C_L = 15\text{ pF}$ |
| Output Enable Time To Low Level | t_{PZL} | | 15 | 30 | ns | $C_L = 15\text{ pF}$ |
| Output Disable Time From High Level | t_{PHZ} | | 15 | 30 | ns | $C_L = 15\text{ pF}$ |
| Output Disable Time From Low Level | t_{PLZ} | | 15 | 30 | ns | $C_L = 15\text{ pF}$ |
| $V_{DD1} = +3.3\text{ V}$, $V_{DD2} = +5\text{ V}$ | | | | | | |
| Parameters | Symbol | Min. | Typ. ⁽⁵⁾ | Max. | Units | Test Conditions |
| Data Rate | | 40 | | | Mbps | $R_L = 54\text{ }\Omega$, $C_L = 50\text{ pF}$ |
| Propagation Delay ^(2, 9) | t_{PD} | | 25 | 35 | ns | $V_O = -1.5$ to 1.5 V , $C_L = 15\text{ pF}$ |
| Pulse Skew ^(2, 10) | $t_{SK}(P)$ | | 2 | 5 | ns | $V_O = -1.5$ to 1.5 V , $C_L = 15\text{ pF}$ |
| Skew Limit ⁽³⁾ | $t_{SK}(LIM)$ | | 4 | 10 | ns | $R_L = 54\text{ }\Omega$, $C_L = 50\text{ pF}$ |
| Output Enable Time To High Level | t_{PZH} | | 17 | 30 | ns | $C_L = 15\text{ pF}$ |
| Output Enable Time To Low Level | t_{PZL} | | 17 | 30 | ns | $C_L = 15\text{ pF}$ |
| Output Disable Time From High Level | t_{PHZ} | | 17 | 30 | ns | $C_L = 15\text{ pF}$ |
| Output Disable Time From Low Level | t_{PLZ} | | 17 | 30 | ns | $C_L = 15\text{ pF}$ |

Dynamic Power Consumption

IsoLoop Isolators achieve their low power consumption from the way they transmit data across the isolation barrier. By detecting the edge transitions of the input logic signal and converting these to narrow current pulses, a magnetic field is created around the GMR Wheatstone bridge. Depending on the direction of the magnetic field, the bridge causes the output comparator to switch following the input logic signal. Since the current pulses are narrow, about 2.5 ns, the power consumption is independent of mark-to-space ratio and solely dependent on frequency. This has obvious advantages over optocouplers, which have power consumption heavily dependent on frequency and time.

Table 2. Typical Dynamic Supply Currents.

| Data Rate (Mbps) | I _{DD1} | I _{DD2} |
|------------------|------------------|------------------|
| 1 | 150 μ A | 150 μ A |
| 10 | 1.5 mA | 1.5 mA |
| 20 | 3 mA | 3 mA |
| 40 | 6 mA | 6 mA |

Power Supply Decoupling

Both V_{DD1} and V_{DD2} must be bypassed with 47 nF ceramic capacitors. These should be placed as close as possible to V_{DD} pins for proper operation. Additionally, V_{DD2} should be bypassed with a 10 μ F tantalum capacitor.

DC Correctness

The IL3685 incorporates a patented refresh circuit to maintain the correct output state with respect to data input. At power up, the bus outputs will follow the Function Table shown on Page 1. The DE input should be held low during power-up to eliminate false drive data pulses from the bus. An external power supply monitor to minimize glitches caused by slow power-up and power-down transients is not required.

Application Information

Receiver Features

The receiver output “R” has tri-state capability via the active low \overline{RE} input.

Driver Features

The RS-485 driver has a differential output and delivers at least 2.1 V across a 54 Ω load. Drivers feature low propagation delay skew to maximize bit width and minimize EMI. Drivers have tri-state capability via the active-high DE input.

Receiver Data Rate, Cables and Terminations

The IL3685 is intended for networks up to 4,000 feet (1,200 m), but the maximum data rate decreases as cable length increases. Twisted pair cable should be used in all networks since they tend to pick up noise and other electromagnetically induced voltages as common mode signals, which are effectively rejected by the differential receiver.

Fail-Safe Operation

“Fail-safe operation” is defined here as the forcing of a logic high state on the “R” output in response to an open-circuit condition between the “A” and “B” lines of the bus, or when no drivers are active on the bus.

Proper biasing can ensure fail-safe operation, that is a known state when there are no active drivers on the bus. IL3000-Series Isolated Transceivers include internal pull-up and pull-down resistors of approximately 30 k Ω in the receiver section (R_{FS-INT}; see figure below). These internal resistors are designed to ensure failsafe operation but only if there are no termination resistors. The entire V_{DD} will appear between inputs “A” and “B” if there is no loading and no termination resistors, and there will be more than the required 200 mV with up to four RS-485 worst-case Unit Loads of 12 k Ω . Many designs operating below 1 Mbps or less than 1,000 feet are unterminated. Termination resistors may not be necessary for very low data rates and very short cable runs because reflections have time to settle before data sampling, which occurs at the middle of the bit interval.

In busses with low-impedance termination resistors however, the differential voltage across the conductor pair will be close to zero with no active drivers. In this case the state of the bus is indeterminate, and the idle bus will be susceptible to noise. For example, with 120 Ω termination resistors (R_T) on each end of the cable, and four Unit Loads (12 k Ω each), without external fail-safe biasing resistors the internal pull-up and pull-down resistors will produce a voltage between inputs “A” and “B” of only about 5 mV. This is not nearly enough to ensure a known state.

External fail-safe biasing resistors (R_{FS-EXT}) at one end of the bus can ensure fail-safe operation with a terminated bus. Resistors should be selected so that under worst-case power supply and resistor tolerances there is at least 200 mV across the conductor pair with no active drivers to meet the input sensitivity specification of the RS-485 standard.

Using the same value for pull-up and pull-down biasing resistors maintains balance for positive- and negative going transitions. Lower-value resistors increase inactive noise immunity at the expense of quiescent power consumption. Note that each Unit Load on the bus adds a worst-case loading of 12 k Ω across the conductor pair, and 32 Unit Loads add 375 Ω worst-case loading. The more loads on the bus, the lower the required values of the biasing resistors.

In the example with two 120 Ω termination resistors and four Unit Loads, 560 Ω external biasing resistors provide more than 200 mV between "A" and "B" with adequate margin for power supply variations and resistor tolerances. This ensures a known state when there are no active drivers. Other illustrative examples are shown in the table below.

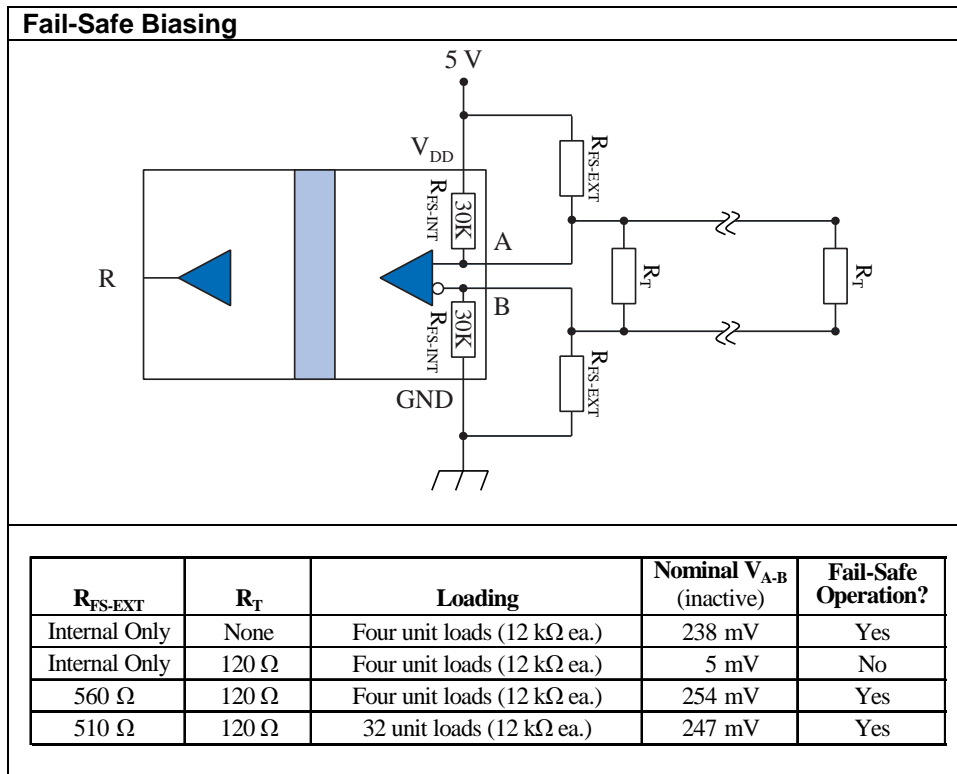

Package Drawings, Dimensions and Specifications

0.3" 16-pin SOIC Package

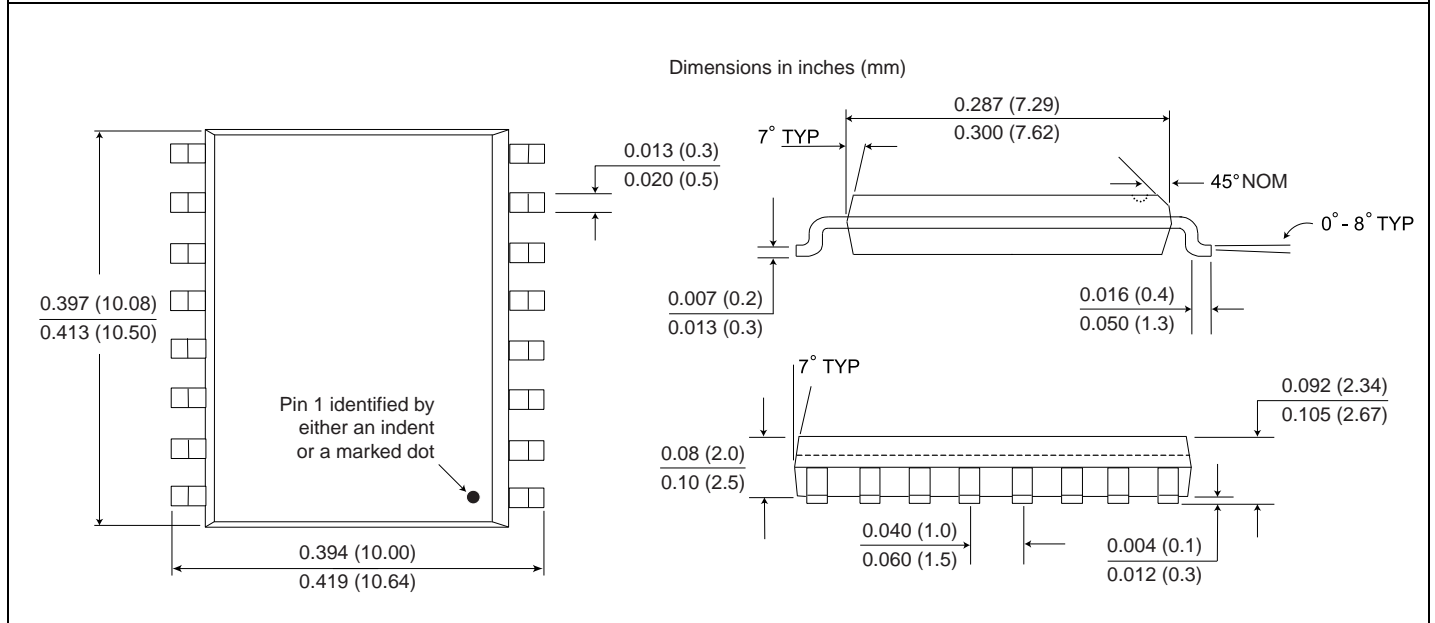

Ordering Information and Valid part Numbers

IL 3685 E TR13

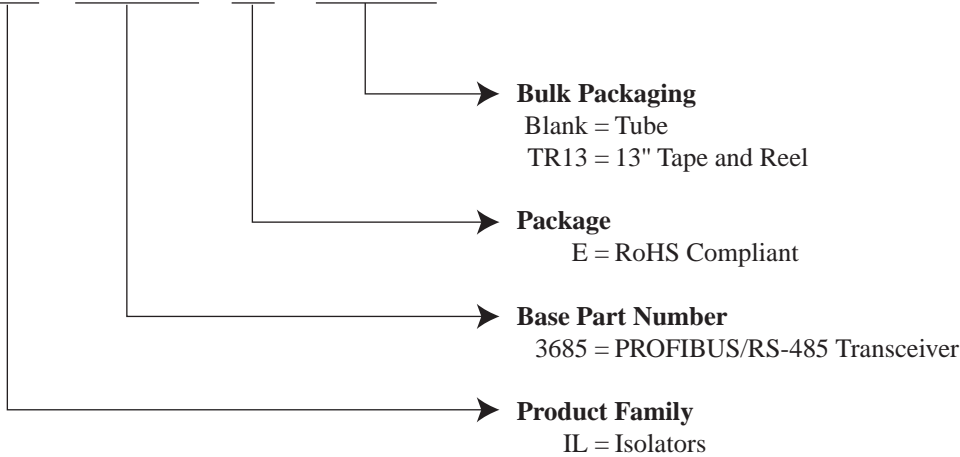

Valid Part Numbers
 IL3585E
 IL3585E TR13



Revision History

ISB-DS-001-IL3685-B
September 2007

Change

- Changed ordering information to reflect that devices are now fully RoHS compliant with no exemptions.

ISB-DS-001-IL3685-A

Initial Release

About NVE

An ISO 9001 Certified Company

NVE Corporation manufactures innovative products based on unique spintronic Giant Magnetoresistive (GMR) technology. Products include Magnetic Field Sensors, Magnetic Field Gradient Sensors (Gradiometers), Digital Magnetic Field Sensors, Digital Signal Isolators, and Isolated Bus Transceivers.

NVE pioneered spintronics and in 1994 introduced the world's first products using GMR material, a line of ultra-precise magnetic sensors for position, magnetic media, gear speed and current sensing.

NVE Corporation
11409 Valley View Road
Eden Prairie, MN 55344-3617 USA
Telephone: (952) 829-9217
Fax: (952) 829-9189
Internet: www.nve.com
e-mail: isoinfo@nve.com

The information provided by NVE Corporation is believed to be accurate. However, no responsibility is assumed by NVE Corporation for its use, nor for any infringement of patents, nor rights or licenses granted to third parties, which may result from its use. No license is granted by implication, or otherwise, under any patent or patent rights of NVE Corporation. NVE Corporation does not authorize, nor warrant, any NVE Corporation product for use in life support devices or systems or other critical applications, without the express written approval of the President of NVE Corporation.

Specifications are subject to change without notice.

ISB-DS-001-IL3685-B

September 2007