

MULTILAYER PIEZO CERAMIC SPEAKER SPECIFICATIONS



广州市番禺奥迪威电子有限公司

Audiowell Electronics (Guangzhou) Co., Ltd.

地址: 中国广东省广州市番禺区迎宾路东升工业区 邮政编码: 511400
 Add: Dongsheng Industrial Park, Yingbin Road, Panyu, Guangzhou 511400, China
 Tel: +86-20-84802041 84802405 84871596 34516785 Fax: 84665207



承 认 书

SPECIFICATION FOR APPROVAL

客户 CUSTOMER			
客户料号 CUST P/N			
名称 NAME		型号 MODEL	
版本 Ver.		日期 DATE	

客户签认 CUSTOMER APPROVAL	承认 APPD.	承认章 COMPANY CHOP

出图 DRAWING	制作 DWN.	审核 CHK.	核准 APPD.

注：承认书一式两份，请返回一份 PLEASE SENT ONE OF THE SAME TWO BACK

Content :

- **1. Characteristics and applications**
- **2. Model**
- **3. Appearance and Dimensions**
- **4. Electrical Specifications**
- **5. Frequency**
- **6. Test method**
- **7. Mechanical, Environment and Life Characteristics**
- **8. Recommended Circuits**
- **9. Recommended Design & installation**
- **10. Suggestions and notices**
- **11. Package**

MULTILAYER PIEZO CERAMIC SPEAKER SPECIFICATIONS

■ 1.Characteristics and applications:

As one of our MLCT(MULTILAYER CERAMIC TRANSMITTER) series, this product is in multilayer ceramic structure. Thanks to its high power density, it can get high output with a low driving voltage.

Its main characteristics include:

- 1) simple acoustic design- which can be installed in a narrow and flat space;
- 2) milliwatts of power consumption and high conversion efficiency, which makes it used widely;
- 3) water-proof design
- 4) it won't cause any electromagnetic interference to surrounding electronic devices and is good at anti-electromagnetic interference.

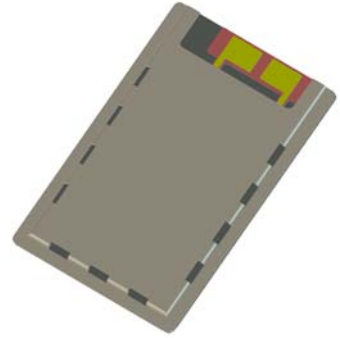

It can be widely used in digital products, general instruments and home appliances. In the humid condition, it can work as voice reminder and music player. In some special fields, it can be used for sound transfer and conversion.

■ 2.Model: MT0006-002 AWMT3020Y05-082

■ 3. Appearance and Dimensions

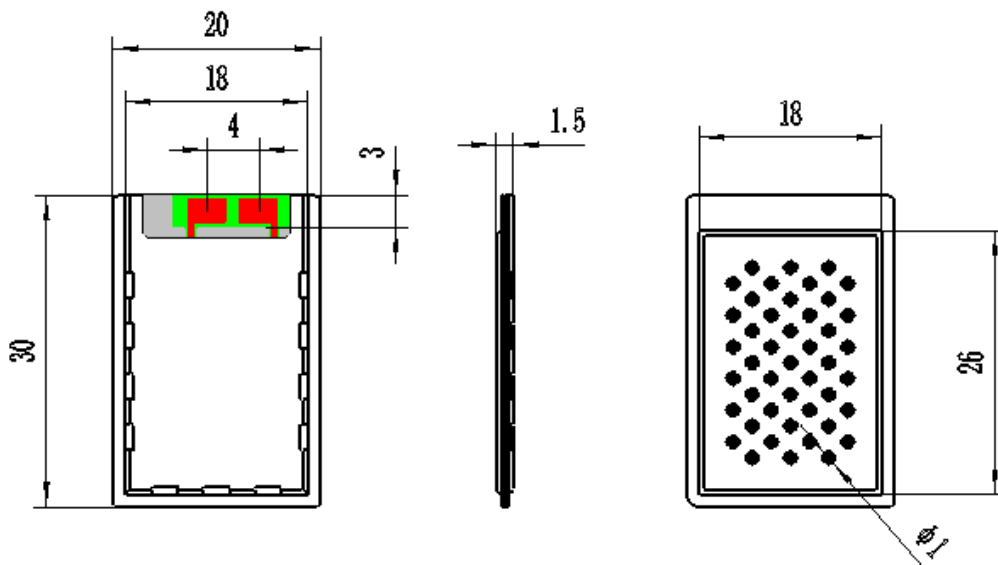

UNIT: mm

MULTILAYER PIEZO CERAMIC SPEAKER SPECIFICATIONS

■ 4. Electrical Specifications:

No.	item	unit	Specifications	Test conditions
1	声压 (S.P.L) Sound Pressure Level	dB	80Min.	B&K(10cm/5Vrms/at muffle room) (Average at 4-point: 1.0K、1.5K、 2.0K、2.5K)
2	静态电容量 (C) Electrostatic Capacity	nF	1200±30%	Digital electric bridge (120Hz/1V/25℃)
3	共振频率 (F0)	Hz	800±100	B&K (5Vrms)
4	频率范围 Frequency Range	Hz	300~20000	-----
5	Max Input Voltage	Vp-p	16	-----
6	工作温度 Operating Temp.	℃	-20 ~ +70	-----
7	存贮温度 Storage Temp	℃	-30 ~ +85	-----

■ 5. Typical Frequency Curve

THD + Rub&Buzz

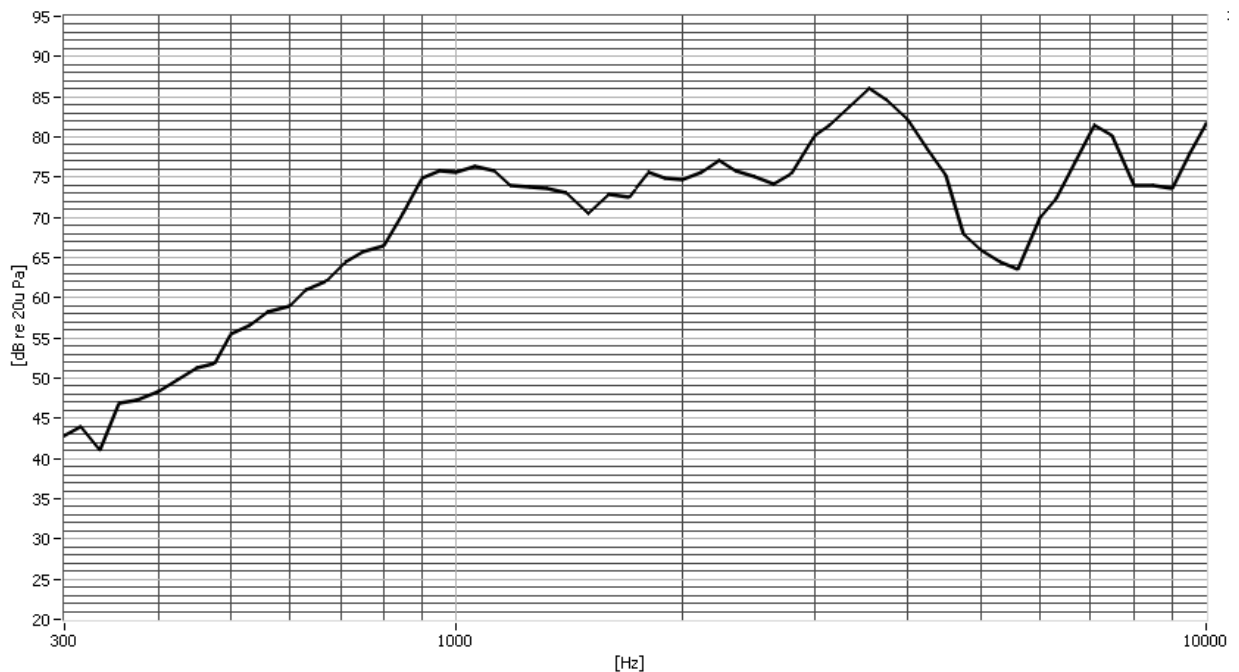

■ 6. Test method

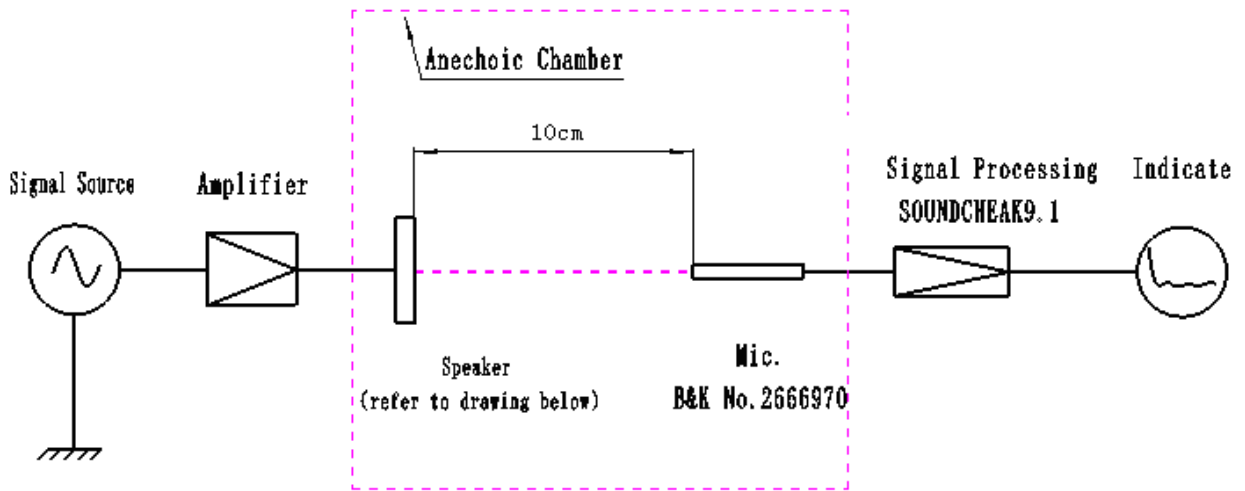

The speaker, being tested in an anechoic chamber, is installed in a baffle of 135cmx165cm.

Conditions of testing:

10cm between microphone and the centre of speaker

Voltage: 5Vrms

Sweep frequency range: 300Hz -10KHz

■ 7. Mechanical, Environment and Life Characteristics

No	Experiment Item	Conditions	Test Standard
1	Shocking Test	Room temp. Sweep Fre.. 10—55Hz Amplitude 1.5mm/XYZ axis/2 Hrs	SPL should be met Initial average±3dB (1KHz/1.5KHz/2KHz/2.5KHz)
2	Drop Test	Put it in a Jig with its weight 150g, dropping in 6 directions of surfaces with 3 times per surface under the height of 150cm	
3	Salt Test	Put the PCB in salt mist for 24 Hrs (+35℃, mass percent of NaCl :5%)	4 hours in +25±3℃ after testing, slight oxidization is allowed on condition being qualified with soldering test and SPL should be met the Initial average±3dB (1.5KHz/2.0KHz/2.5KHz/3KHz)
4	Storage under High temp.	85±2℃ /240 hous, then 4 Hrs in room temp.	SPL average±3dB (1KHz/1.5KHz/2KHz/2.5KHz)
5	Storage under Low temp.	-30±2℃ /240 hours, then 4 Hrs in room temp.	
6	Storage under High temp.& humid	+60±2℃ /RH90—95%/240Hrs, then 4 Hrs in room temp.	
7	Power on UnderHigh temp.,humid	+60±2℃ /RH90—95%/240Hrs/5Vrms (300~20000Hz/ Step10Hz/ LT10s), then 4 Hrs in room temp.	
8	thermal shock	-30℃ /30mins., then put it in +85℃ within 2-3min for 30mins., repeat 20 times, then 4 hours in room temp.	
9	Max Voltage	Loading Voltage 16Vpp/0.5 hour in room temp (Fre.300~20000Hz,Step:10Hz,LT: 10s) . The voltage is setted to be the Max Value of Voltage as per the required in the Specm then 4 Hrs in room temp.	
10	Lift Test	Under room temp., make it at work for 240 hours at 5Vrms/1KHz, then 4 hours in room temp.	

■ 8. Circuit:

8.1 Circuit: EUA6288 (Vout:14V)

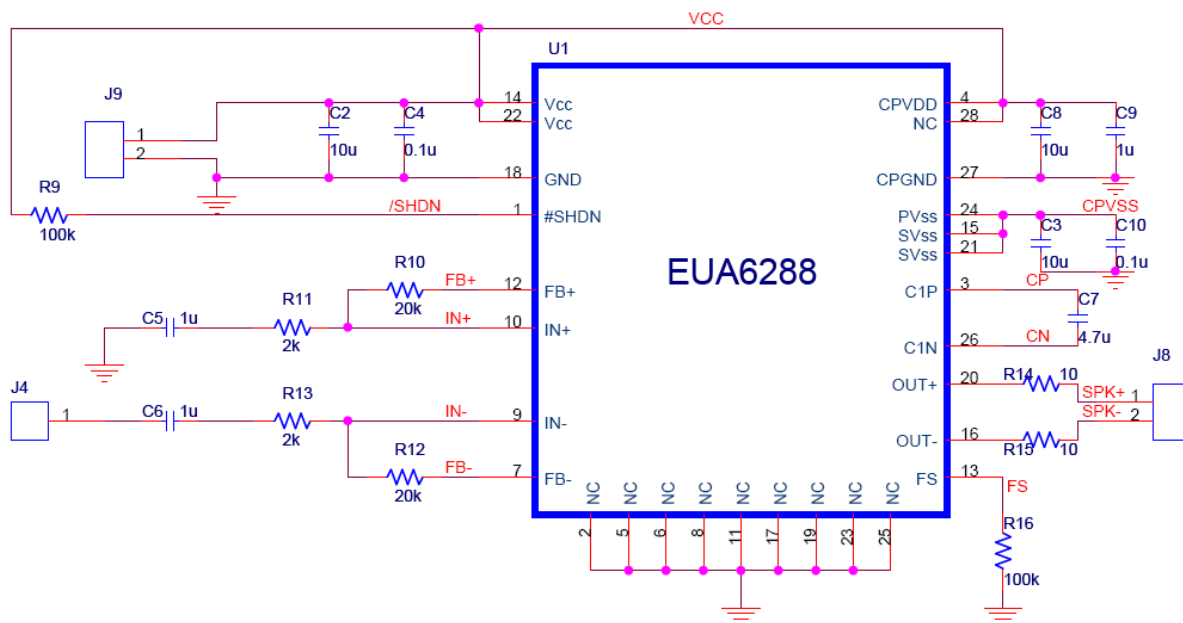

8.2 Circuit: SN3500+SN4915(Vout: 20V)

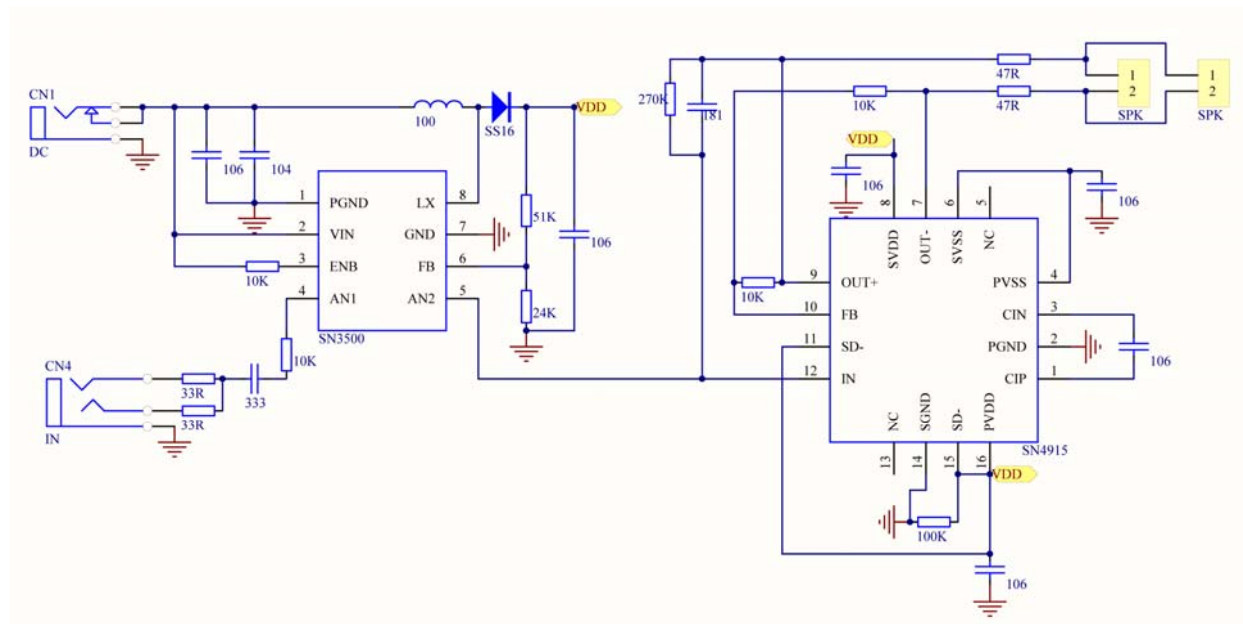

8.3应用线路: LMV832MM+LM48580TL方案(Vout: 24V)

MULTILAYER PIEZO CERAMIC SPEAKER SPECIFICATIONS

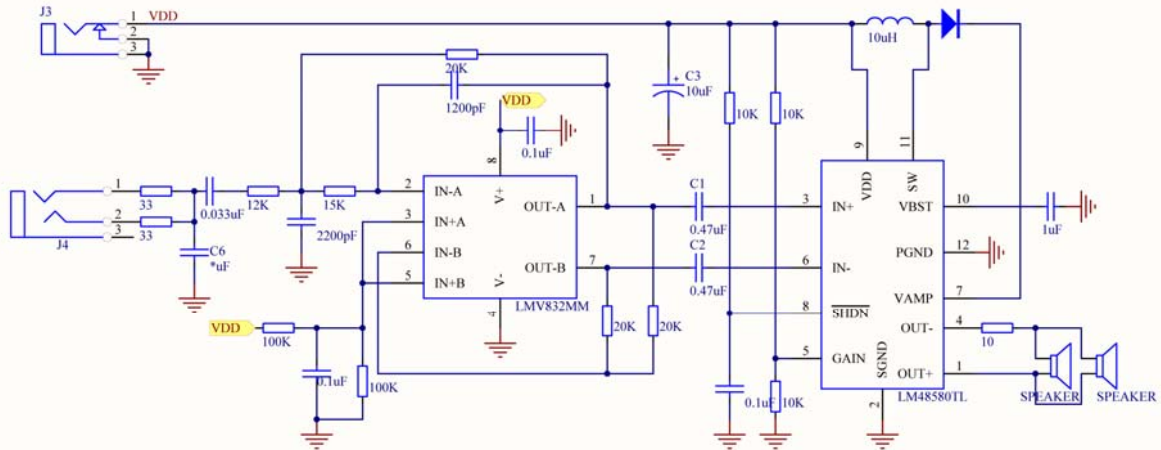

8.4 Circuit: MAX9788(Vout: 14V)

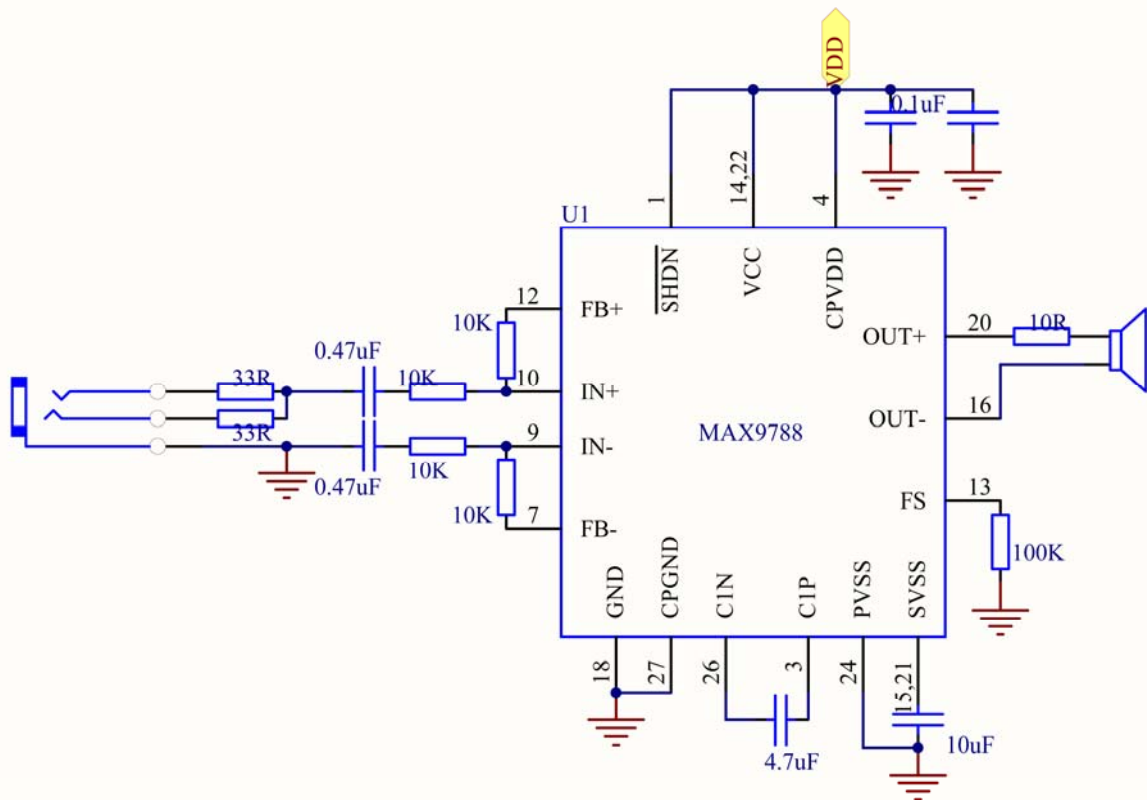

8.5 The Voltage for above recommended circuits are under low 2.7-5.5V. If working under voltage, please refer to other designs.

■ 9. Design and installation:

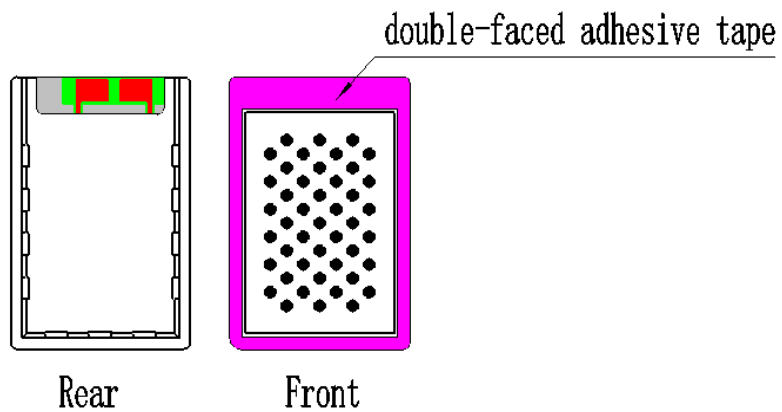
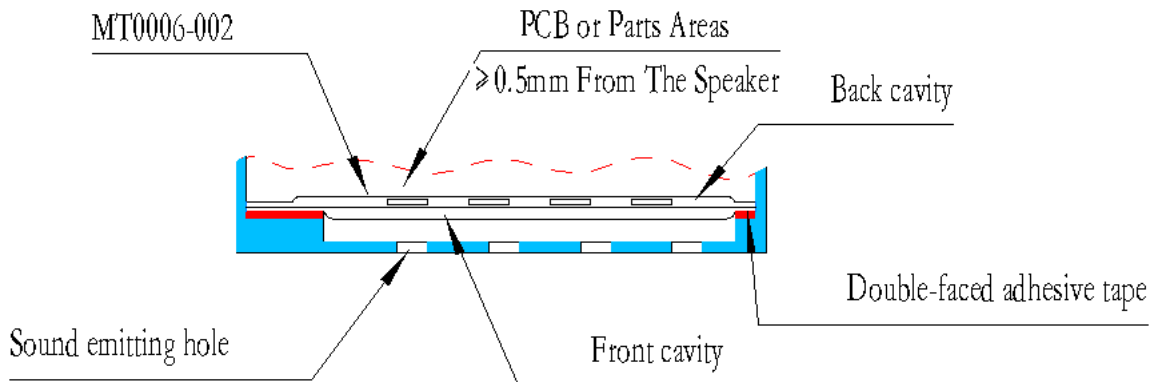

■ 10. Suggestions and notices:

10.1 The front and back chamber cover can use the covers of the machine. For example, if it is installed in a cell phone, there is no need for extra design of chamber.

10.2 The following three situations which cause murmurs, vibrato and resonance should be avoided: the structure of facility is not firmly fixed; Audio cable of Speaker contacts the vibrating area of it; speaker itself is not fixed well.

10.3 The chamber which is shaped by the sealed adhesives and the Surrounding structure should be kept sealed. If you want a sound hole, please refer to the design 9. The distance between front cover and speaker is more than 0.5mm.

10.4 The distance from the back cover to the structural parts and other electrical components should be more than 0.5mm, so as to avoid any contact or friction with the speaker.

10.5 Suggestion: Back chamber should be separated and sealed($\geq 0.7\text{cc}$). The bigger chamber is, the better for sound quality. The back chamber should be sealed during assembly avoid the sound leaked, which effects the sound quality and volume .

10.6 During installation, Please don't pressure too much on the speaker in vertical direction

MULTILAYER PIEZO CERAMIC SPEAKER SPECIFICATIONS

■ 11. Package:

