

Ultra-low Power Consumption 300 mA Buck DC/DC Converter with Battery Monitor

No.EA-505-190328

OVERVIEW

The RP515x is a buck DC/DC converter with a Battery Monitor (BM) featuring ultra-low current and low-voltage resistance. The battery monitor divides the input voltage (V_{IN}) into 1/3 or 1/4, and directly provides the MCU's built-in low voltage AD converter with buffered voltage without external circuits.

KEY BENEFITS

- Ultra-low consumption current (I_Q : 0.3 μ A) with the VFM control for DC/DC (switching frequency: 1 MHz max.)
- High efficiency under light load conditions
- Reducing components and space by combining DC/DC and BM into a single chip
- Suitable for coin batteries and USB ports due to its wide input voltage range from 1.8 V to 5.5 V

KEY SPECIFICATIONS

DC/DC Section

- Supply Current: Typ. 0.3 μ A
- Output Current: 300 mA
- Input Voltage Range: 1.8 V to 5.5 V
- Output Voltage Range : 1.0 V to 4.0 V
- Output Voltage Accuracy: $\pm 1.5\%$

Battery Monitor Section

- Output Voltage: $V_{IN} / 3$ (RP515xxx3x)
 $V_{IN} / 4$ (RP515xxx4x)
- Supply Current: Typ. 0.1 μ A

PACKAGES



WLCSP-9-P2
1.45 x 1.48 x 0.36 (mm)

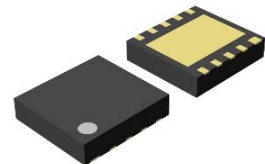

DFN(PL)2527-10
2.7 x 2.5 x 0.6 (mm)

TYPICAL APPLICATIONS

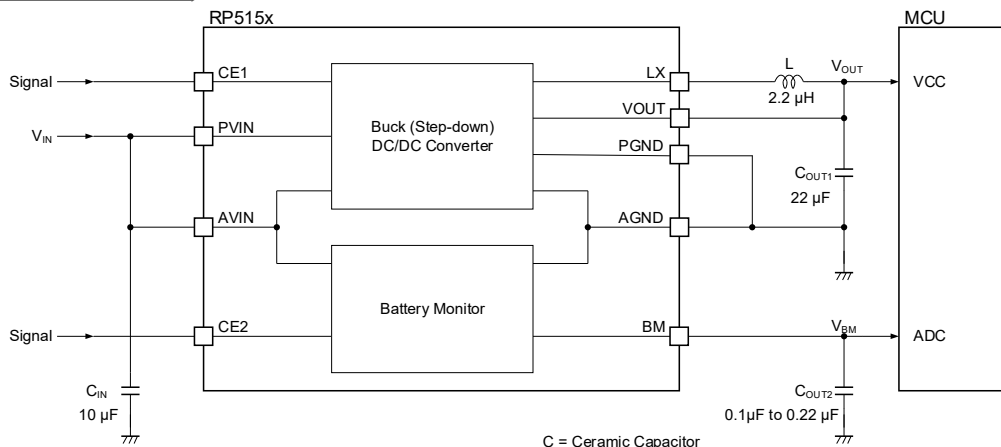

APPLICATIONS

- Coin cell-used equipment and Li-ion battery-used equipment
- Wearable devices such as SmartWatch, SmartBand and Health monitoring
- Low Power RF Modules such as *Bluetooth*[®] LE, Zigbee, WiSun and ANT
- Low Power CPU, Memory, Sensor device and Energy Harvester

RP515x

No.EA-505-190328

SELECTION GUIDE

The set output voltage for DC/DC, the division ratio of BM output voltage, the auto-discharge function ⁽¹⁾ for DC/DC and the packages are user-selectable options.

Selection Guide

Product Name	Package	Quantity per Reel	Pb Free	Halogen Free
RP515Zxx#-\$-TR-F	WLCSP-9-P2	5,000 pcs	Yes	Yes
RP515Kxx#-\$-TR	DFN(PL)2527-10	5,000 pcs	Yes	Yes

xx: Specify the set output voltage for DC/DC (V_{SET}).within the range from 1.0 V (10) to 4.0 V (40)

The voltage in 0.05 V step is shown as follows:

Ex. 1.25 V: RP515x12xx5

Refer to the *Product-specific Electrical Characteristics* for detailed information.

* Contact our sales representatives for other voltages.

#: Select the division ratio of BM output voltage

3: $V_{IN}/3$

4: $V_{IN}/4$

\$: Select the auto-discharge option for DC/DC.

C: DC/DC auto-discharge is not included

D: DC/DC auto-discharge is included

⁽¹⁾ Auto-discharge function quickly lowers the output voltage to 0 V by releasing the electrical charge accumulated in the external capacitor, when the chip enable signal is switched from the active mode to the standby mode.

BLOCK DIAGRAMS

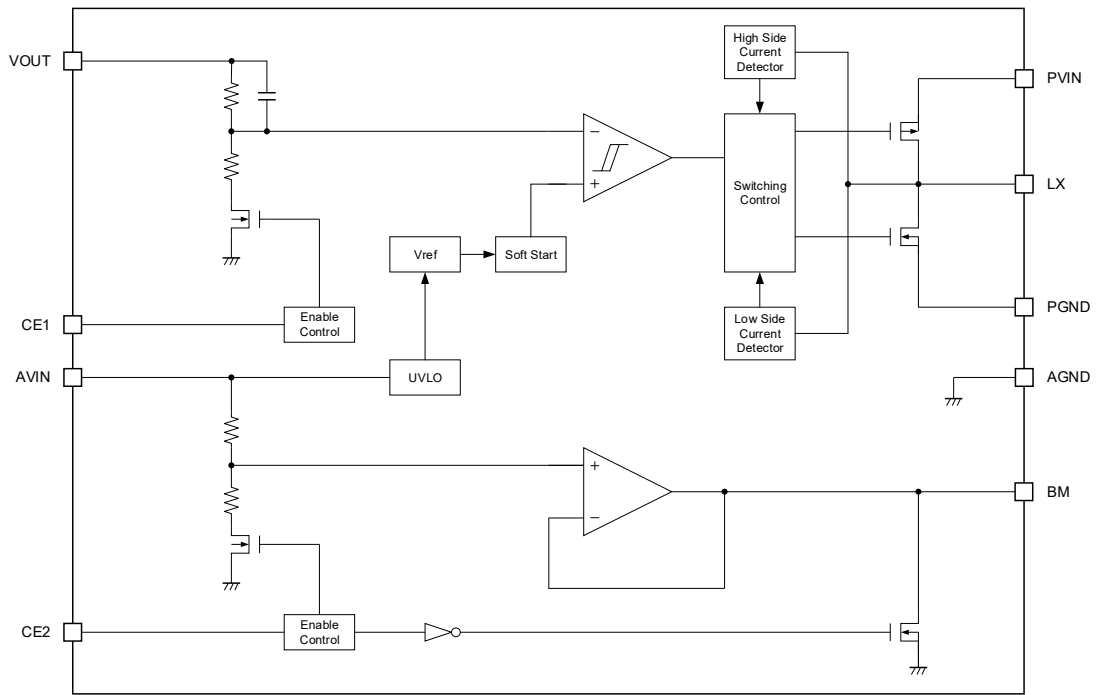

RP515xxx C Block Diagram: Without DC/DC auto-discharge function

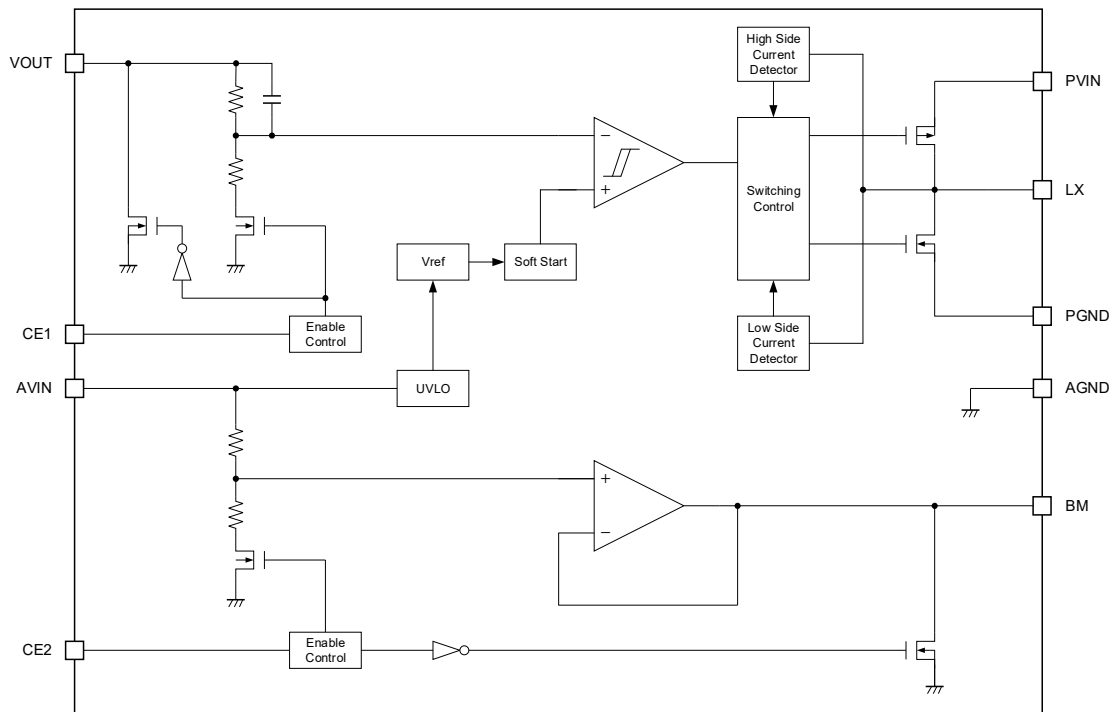

RP515xxx D Block Diagram: With DC/DC auto-discharge function

RP515x

No.EA-505-190328

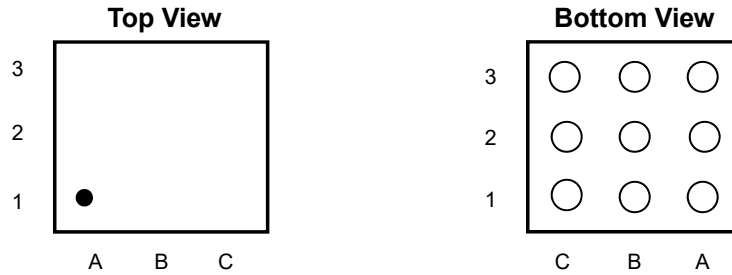
PIN DESCRIPTIONS**RP515Z (WLCSP-9-P2) Pin Configuration****RP515Z Pin Description**

Pin No.	Symbol	Description
A1	AVIN	Input Pin for Analog Power Supply (also for Battery Monitor)
B1	PVIN	Input Pin for Power Supply
C1	LX	Switching Pin
A2	CE1	DC/DC Enable Pin (Active-high)
B2	CE2	Battery Monitor Enable Pin (Active-high)
C2	PGND	Power Ground Pin
A3	BM	Battery Monitor Output Pin
B3	VOUT	DC/DC Output Pin
C3	AGND	Analog Ground Pin

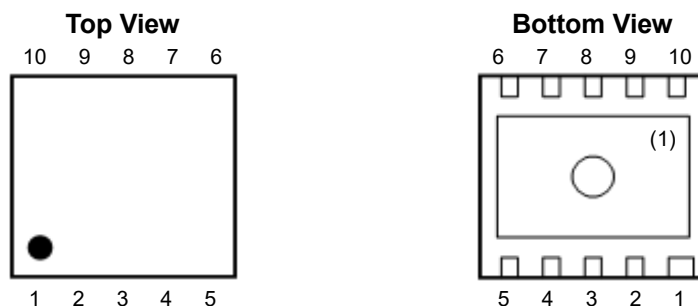

RP515K [DFN(PL)2570-10] Pin Configuration

RP515K Pin Description

Pin No.	Symbol	Description
1	VOUT	DC/DC Output Pin
2	AGND	Analog Ground Pin
3	PGND	Power Ground Pin
4	LX	Switching Pin
5	LX	Switching Pin
6	PVIN	Input Pin for Power Supply
7	AVIN	Input Pin for Analog Power Supply (also for Battery Monitor)
8	CE1	DC/DC Enable Pin (Active-high)
9	CE2	Battery Monitor Enable Pin (Active-high)
10	BM	Battery Monitor Output Pin

⁽¹⁾ The tab on the bottom of the package is substrate level (GND). It is recommended that the tab be connected to the ground plane on the board, but it is possible to leave the tab floating.

RP515x

No.EA-505-190328

ABSOLUTE MAXIMUM RATINGS

Absolute Maximum Ratings

Symbol	Parameter	Rating	Unit	
V_{IN}	Input Voltage for AVIN and PVIN Pins	-0.3 to 6.5	V	
V_{CE1}	CE1 Pin Voltage	-0.3 to 6.5	V	
V_{CE2}	CE2 Pin Voltage	-0.3 to 6.5	V	
V_{OUT}	Output Pin Voltage	-0.3 to $V_{IN} + 0.3$	V	
V_{BM}	BM Pin Voltage	-0.3 to $V_{IN} + 0.3$	V	
I_{LX}	LX Pin Output Current	650	mA	
P_D	Power Dissipation ⁽¹⁾ (JEDEC STD. 51)	WLCSP-9-P2	1090	mW
		DFN(PL)2527-10	2500	
T_j	Junction Temperature Range	-40 to 125	°C	
T_{stg}	Storage Temperature Range	-55 to 125	°C	

ABSOLUTE MAXIMUM RATINGS

Electronic and mechanical stress momentarily exceeded absolute maximum ratings may cause permanent damage and may degrade the life time and safety for both device and system using the device in the field. The functional operation at or over these absolute maximum ratings is not assured.

RECOMMENDED OPERATING CONDITIONS

Recommended Operating Conditions

Symbol	Parameter	Rating	Unit	
V_{IN}	Input Voltage	RP515xxx3x	1.8 to 5.5	V
		RP515xxx4x	2.4 to 5.5	
T_a	Operating Temperature	-40 to 85	°C	

RECOMMENDED OPERATING CONDITIONS

All of electronic equipment should be designed that the mounted semiconductor devices operate within the recommended operating conditions. The semiconductor devices cannot operate normally over the recommended operating conditions, even if they are used over such conditions by momentary electronic noise or surge. And the semiconductor devices may receive serious damage when they continue to operate over the recommended operating conditions.

⁽¹⁾ Refer to *POWEWR DISSIPATION* for detailed information.

ELECTRICAL CHARACTERISTICS

The specifications surrounded by are guaranteed by design engineering at $-40^{\circ}\text{C} \leq T_a \leq 85^{\circ}\text{C}$.

RP515x Electrical Characteristics: DC/DC Section

($T_a = 25^{\circ}\text{C}$)

Symbol	Parameter		Condition	Min.	Typ.	Max.	Unit
V_{OUT}	Output voltage		$V_{\text{IN}} = V_{\text{CE1}} = 3.6 \text{ V}$ ($V_{\text{SET}} \leq 2.6 \text{ V}$),	$V_{\text{SET}} \geq 1.2 \text{ V}$ x 0.985		x 1.015	V
			$V_{\text{IN}} = V_{\text{CE1}} = V_{\text{SET}} + 1 \text{ V}$ ($V_{\text{SET}} > 2.6 \text{ V}$)	$V_{\text{SET}} < 1.2 \text{ V}$	-0.018		
I_{Q}	Operating quiescent current		$V_{\text{IN}} = V_{\text{CE1}} = V_{\text{OUT}} = 5.5 \text{ V}$, $V_{\text{SET}} = 1.8 \text{ V}$ at rest		0.3		μA
I_{STANDBY}	Standby current		$V_{\text{IN}} = 5.5 \text{ V}$, $V_{\text{CE1}} = 0 \text{ V}$		0.01	1	μA
I_{CE1H}	CE1 pin input current, high		$V_{\text{IN}} = V_{\text{CE1}} = 5.5 \text{ V}$	-0.025	0	0.025	μA
I_{CE1L}	CE1 pin input current, low		$V_{\text{IN}} = 5.5 \text{ V}$, $V_{\text{CE1}} = 0 \text{ V}$	-0.025	0	0.025	μA
I_{VOUTH}	V_{OUT} pin input current, high ⁽¹⁾		$V_{\text{IN}} = V_{\text{OUT}} = 5.5 \text{ V}$, $V_{\text{CE1}} = 0 \text{ V}$	-0.025	0	0.025	μA
I_{VOUTL}	V_{OUT} pin input current, low		$V_{\text{IN}} = 5.5 \text{ V}$, $V_{\text{CE1}} = V_{\text{OUT}} = 0 \text{ V}$	-0.025	0	0.025	μA
R_{DISN}	Auto-discharge NMOS on-resistance ⁽²⁾		$V_{\text{IN}} = 3.6 \text{ V}$, $V_{\text{CE1}} = 0 \text{ V}$		60		Ω
V_{CE1H}	CE1 pin input voltage, high		$1.8 \text{ V} \leq V_{\text{IN}} \leq 5.5 \text{ V}$	1.0			V
V_{CE1L}	CE1 pin input voltage, low		$1.8 \text{ V} \leq V_{\text{IN}} \leq 5.5 \text{ V}$			0.4	V
R_{ONP}	PMOS on-resistance	RP515Z	$V_{\text{IN}} = 3.6 \text{ V}$, $I_{\text{LX}} = -100 \text{ mA}$		0.15		Ω
		RP515K			0.19		
R_{ONN}	NMOS on-resistance	RP515Z	$V_{\text{IN}} = 3.6 \text{ V}$, $I_{\text{LX}} = -100 \text{ mA}$		0.15		Ω
		RP515K			0.19		
t_{START}	Soft-start time		$V_{\text{IN}} = V_{\text{CE1}} = 3.6 \text{ V}$ ($V_{\text{SET}} \leq 2.6 \text{ V}$), $V_{\text{IN}} = V_{\text{CE1}} = V_{\text{SET}} + 1 \text{ V}$ ($V_{\text{SET}} > 2.6 \text{ V}$)		10		ms
I_{LXLIM}	LX current limit		$V_{\text{IN}} = V_{\text{CE1}} = 3.6 \text{ V}$ ($V_{\text{SET}} \leq 2.6 \text{ V}$), $V_{\text{IN}} = V_{\text{CE1}} = V_{\text{SET}} + 1 \text{ V}$ ($V_{\text{SET}} > 2.6 \text{ V}$)	300	580		mA
V_{UVLOF}	Undervoltage lockout (UVLO) threshold voltage		$V_{\text{IN}} = V_{\text{CE1}}$, falling	1.40	1.50	1.65	V
V_{UVLOR}			$V_{\text{IN}} = V_{\text{CE1}}$, rising	1.55	1.65	1.80	V

All test items listed under Electrical Characteristics are done under the pulse load condition ($T_j \approx T_a = 25^{\circ}\text{C}$).

⁽¹⁾ RP515xxxxC only

⁽²⁾ RP515xxxxD only

RP515x

No.EA-505-190328

ELECTRICAL CHARACTERISTICS (Continued)The specifications surrounded by are guaranteed by design engineering at $-40^{\circ}\text{C} \leq T_a \leq 85^{\circ}\text{C}$.**RP515x Electrical Characteristics: Battery Monitor Section**

(Ta = 25°C)

Symbol	Parameter	Condition	Min.	Typ.	Max.	Unit	
V _{BM}	Output voltage	RP515xxx3x	V _{IN} = 5.5 V, -10 μA ≤ I _{BM} ≤ 10 μA	V _{IN} /3-30	V _{IN} /3	V _{IN} /3+30	mV
		RP515xxx4x		V _{IN} /4-30	V _{IN} /4	V _{IN} /4+30	
I _{BM}	Output current	V _{IN} = 5.5 V	-10		10	μA	
I _{SSBM}	Supply current	V _{IN} = V _{CE2} = 5.5 V, I _{BM} = 0 μA		0.1		μA	
V _{CE2H}	CE2 pin input voltage, high	1.8 V ≤ V _{IN} ≤ 5.5 V	1.0			V	
V _{CE2L}	CE2 pin input voltage, low	1.8 V ≤ V _{IN} ≤ 5.5 V			0.4	V	
R _{DISNBM}	Auto-discharge NMOS on-resistance	V _{IN} = 4.0 V, V _{CE2} = 0 V		50		Ω	

All test items listed under Electrical Characteristics are done under the pulse load condition (T_j ≈ T_a = 25°C).

ELECTRICAL CHARACTERISTICS (Continued)

Product-specific Electrical Characteristics

RP515xxxxx (Ta = 25°C)

Product name	V _{OUT} [V]		
	Min.	Typ.	Max.
RP515x10xx	0.9820	1.00	1.0180
RP515x12xx	1.1820	1.20	1.2180
RP515x15xx	1.4775	1.50	1.5225
RP515x18xx	1.7730	1.80	1.8270
RP515x24xx	2.3640	2.40	2.4360
RP515x25xx	2.4625	2.50	2.5375
RP515x28xx	2.7580	2.80	2.8420
RP515x30xx	2.9550	3.00	3.0450
RP515x31xx	3.0535	3.10	3.1465
RP515x33xx	3.2505	3.30	3.3495
RP515x36xx	3.5460	3.60	3.6540
RP515x40xx	3.9400	4.00	4.0600

RP515x

No.EA-505-190328

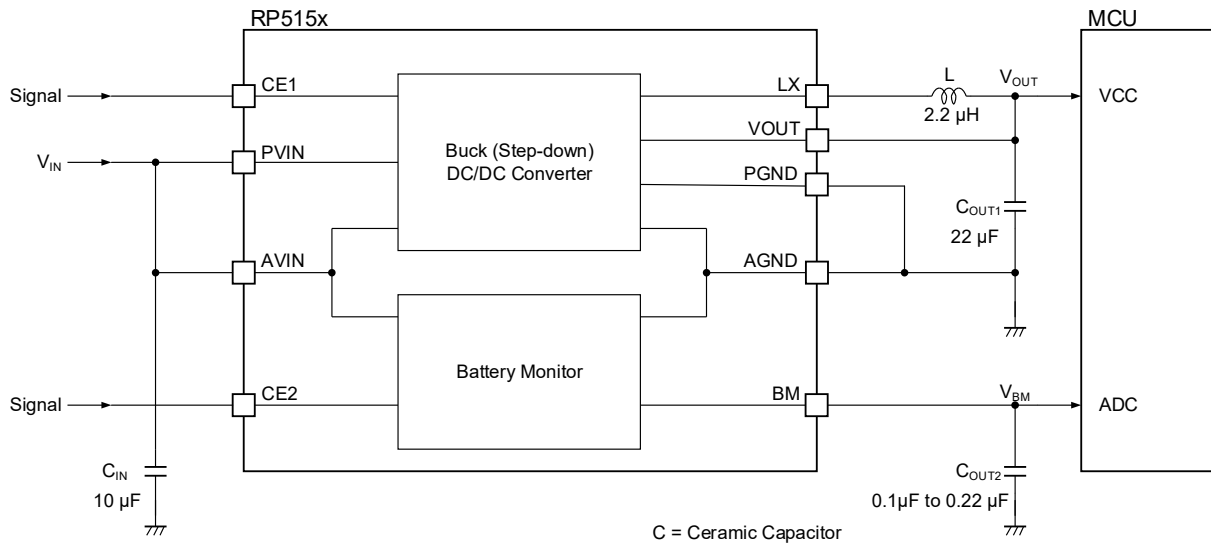
TYPICAL APPLICATION CIRCUIT**RP515x Typical Application Circuit**

TECHNICAL NOTES

The performance of a power source circuit using this device is highly dependent on the peripheral circuit. A peripheral component or the device mounted on PCB should not exceed a rated voltage, a rated current or a rated power. When designing a peripheral circuit, please be fully aware of the following points.

- When an intermediate voltage other than V_{IN} and GND is input to the CE1 pin or/and CE2 pin, a supply current may be increased with a through current of a logic circuit in the IC. The CE pin is neither pulled up nor pulled down, therefore the operation is not stable at open.

THEORY OF OPERATION

DC/DC Section

Soft-start Time

Starting-up with CE1 Pin

The IC starts to operate when the CE1 pin voltage (V_{CE1}) exceeds the threshold voltage. The threshold voltage is preset between CE1 “High” input voltage (V_{CE1H}) and CE1 “Low” input voltage (V_{CE1L}). After the start-up of the IC, soft-start circuit starts to operate. Then, after a certain period of time, the reference voltage (V_{REF}) in the IC gradually increases up to the specified value. Switching starts when V_{REF} reaches the preset voltage, and after that the output voltage rises as V_{REF} increases. Soft-start time (t_{START}) indicates the period from the time soft-start circuit gets activated to the time V_{REF} reaches the specified voltage. t_{START} is not always equal to the turn-on speed of the DC/DC converter. Note that the turn-on speed could be affected by the power supply capacity, the output current (I_{OUT}), the inductance and the output capacitor value (C_{OUT1}).

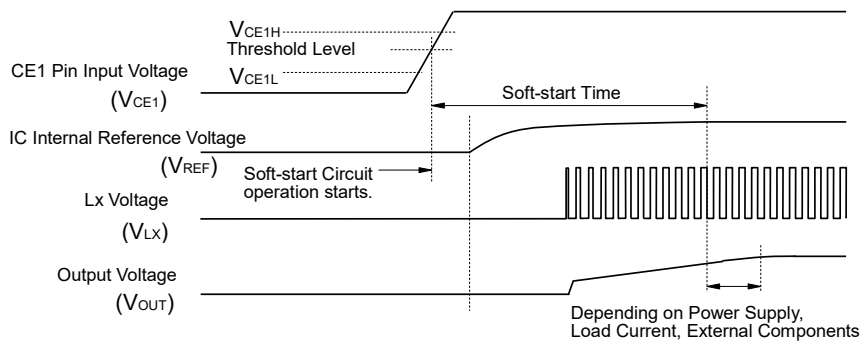

Timing Chart: Starting-up with CE1 Pin

Starting-up with Power Supply

After the power-on, when V_{IN} exceeds the UVLO release voltage (V_{UVLOR}), the IC starts to operate. Then, soft-start circuit starts to operate and after a certain period of time, V_{REF} gradually increases up to the specified value. Switching starts when V_{REF} reaches the preset voltage, and after that the output voltage rises as V_{REF} increases. The turn-on speed of V_{OUT} could be affected by following conditions:

1. The V_{IN} turn-on speed determined by the power supply to the IC and the C_{IN}
2. The output capacitor value (C_{OUT1}) and the output current (I_{OUT})

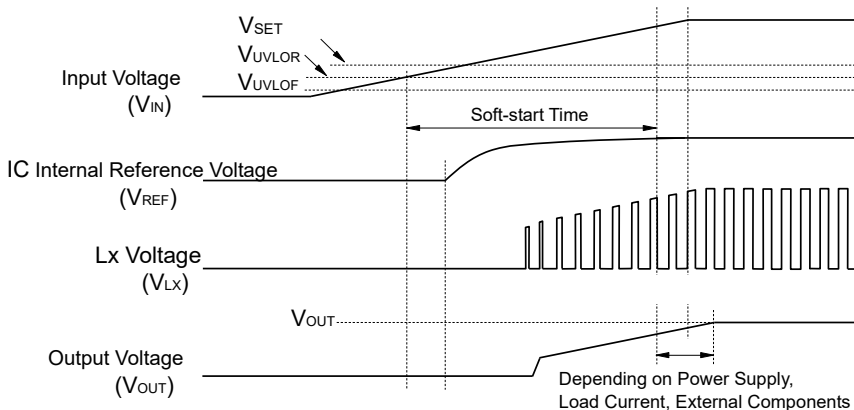

Timing Chart: Starting-up with Power Supply

Undervoltage Lockout (UVLO) Circuit

When V_{IN} becomes lower than V_{SET} , the buck DC/DC converter stops its switching operation and ON duty becomes 100%, then V_{OUT} gradually falls according to V_{IN} . When the V_{IN} drops below the UVLO detector threshold (V_{UVLOF}), the UVLO operates, V_{REF} stops, and PMOS and NMOS built-in switch transistors turn "OFF". As a result, V_{OUT} drops according to the C_{OUT1} capacitance value and I_{OUT} . As for RP515xxx1D, the discharge transistor for C_{OUT1} discharges after it turns on.

To restart the operation, V_{IN} needs to exceed V_{UVLOR} . The timing chart below shows the voltage shifts of V_{REF} , V_{LX} and V_{OUT} when V_{IN} value is varied.

Note: Falling edge (operating) and rising edge (releasing) waveforms of V_{OUT} could be affected by the initial voltage of C_{OUT1} and the output current of V_{OUT} .

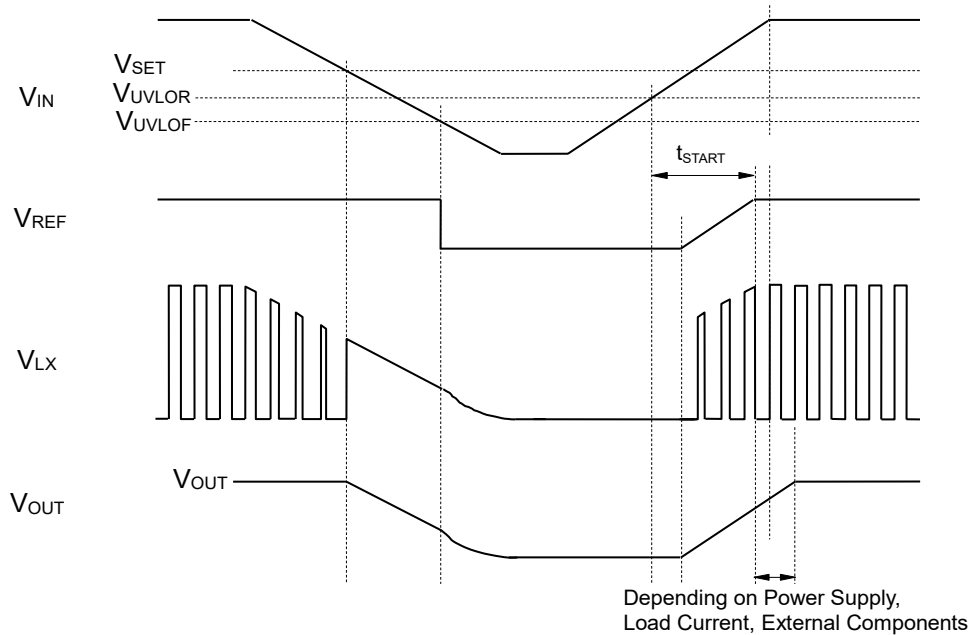

Timing Chart with Variations in Input Voltage (V_{IN})

Operation of Buck DC/DC Converter and Output Current

The buck DC/DC converter charges energy in the inductor while LX transistor turns “ON”, and discharges the energy from the inductor when LX transistor turns “OFF”. This inductor reduces the energy loss to provide the lower output voltage (V_{OUT}) than the input voltage (V_{IN}). The operation of the buck DC/DC converter is shown in the following figures.

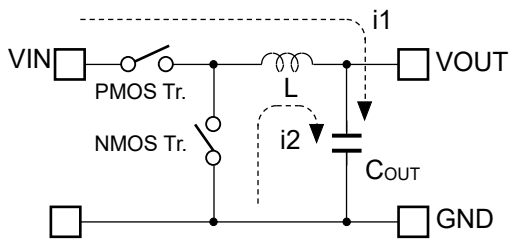

Basic Circuit

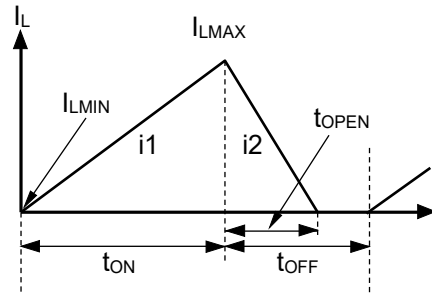

Inductor Current (I_L) flowing through Inductor (L)

- Step1.** When the PMOS transistor turns “ON”, I_L (i_1) flows through the L to charge C_{OUT} and provide I_{OUT} . At this moment, i_1 increases from the minimum inductor current (I_{LMIN}) of 0 A to reach the maximum inductor current (I_{LMAX}) in proportion to the on-time period (t_{ON}) of PMOS transistor.
- Step2.** When PMOS transistor turns “OFF”, L turns NMOS transistor “ON” to maintain I_L at I_{LMAX} and I_L (i_2) flows into L.
- Step3.** $I_L = i_2$ decreases gradually and reaches I_{LMIN} after the open-time period (t_{OPEN}) of NMOS transistor and NMOS transistor turns “OFF”. This is called discontinuous current mode.
As to the continuous current mode, the output current (I_{OUT}) increases and the off-time period (t_{OFF}) of PMOS transistor ends before I_L reaches I_{LMIN} . In the next cycle, PMOS transistor turns “ON” and NMOS transistor turns “OFF”, then I_L increases from $I_L = I_{LMIN} > 0$.

When the buck DC/DC operation is constant, I_{LMIN} and I_{LMAX} during t_{ON} of PMOS transistor would be same as during t_{OFF} of PMOS transistor. The difference of the current between I_{LMAX} and I_{LMIN} represents ΔI as shown in the following equation 1.

$$\Delta I = I_{LMAX} - I_{LMIN} = V_{OUT} \times t_{OPEN} / L = (V_{IN} - V_{OUT}) \times t_{ON} / L \dots\dots\dots (1)$$

VFM Mode

The VFM (Variable Frequency Modulation) mode is adopted as a switching method to achieve a high efficiency under light load conditions. A switching frequency varies depending on values of input voltage (V_{IN}), output voltage (V_{OUT}), and output current (I_{OUT}). Check the actual characteristics to avoid the switching noise.

A switching starts when V_{OUT} drops below the lower-limit reference voltage (V_{REFL}). When V_{OUT} exceeds the upper-limit reference voltage (V_{REFH}), a constant voltage is output by a hysteresis control which stops the switching.

In order to operate within the rated characteristic of inductor and avoid the deteriorated band frequency of DC superimposed characteristics, when the inductor current (I_L) exceeds LX current limit (I_{LXLIM}), the operation shifts to off-cycle. And when I_L drops below the valley current limit (I_{LXVAL}), the operation shift to on-cycle.

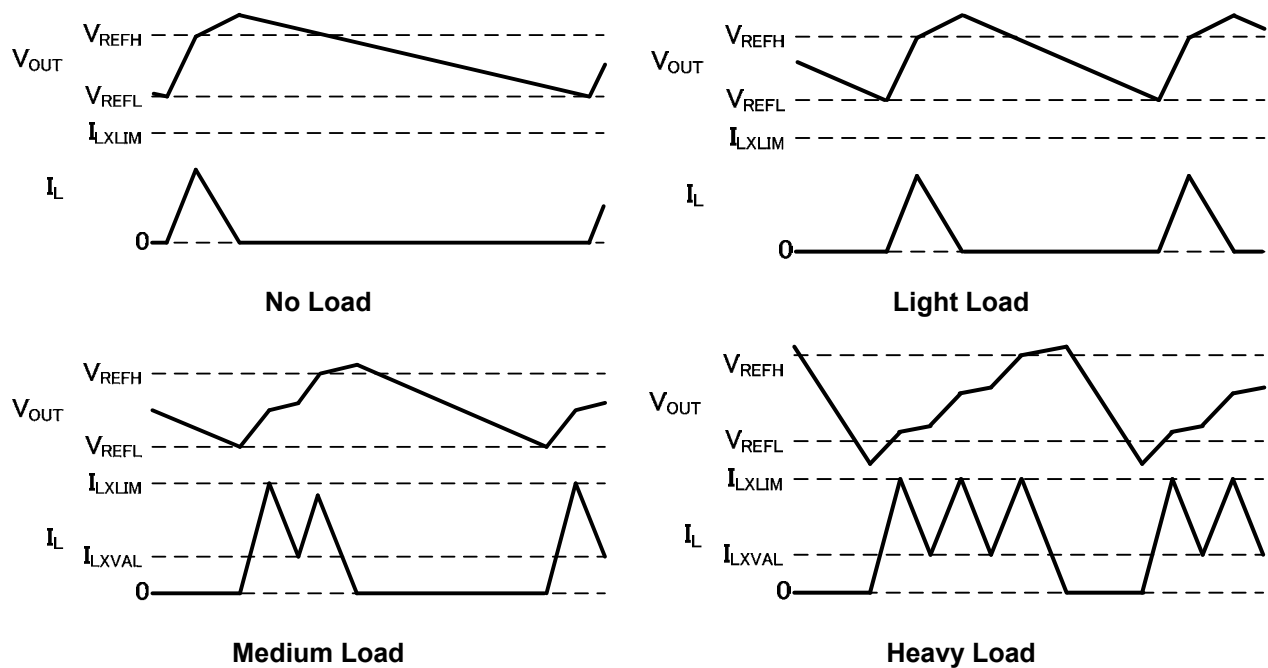

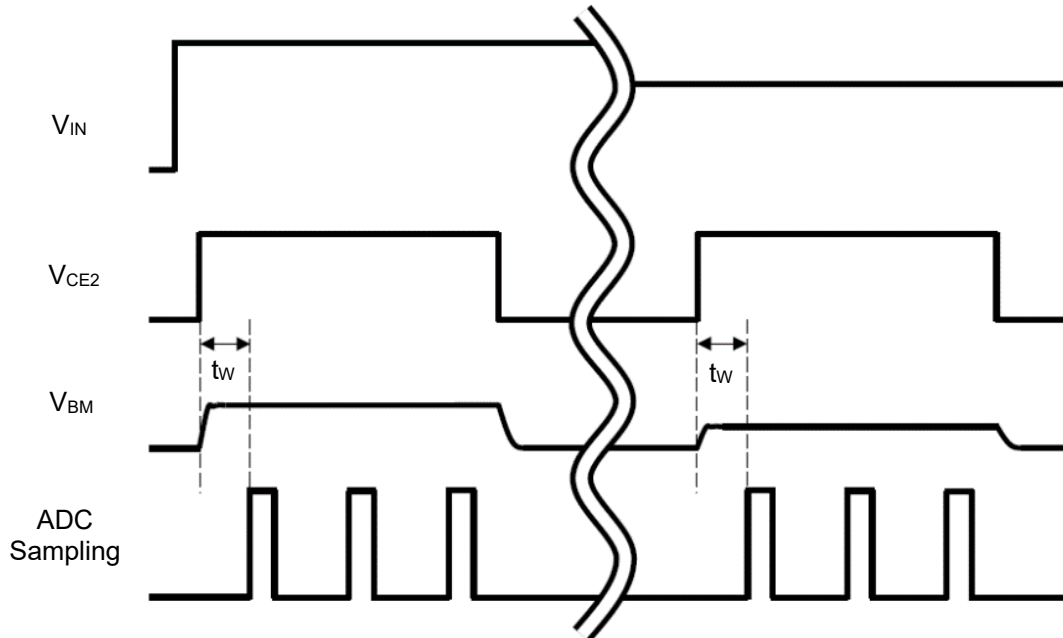
Battery Monitor Section
Timing Chart of Typical Application Circuit

RP515x Timing Chart of Typical Application Circuit

The RP515x can monitor the battery voltage by connecting BM pin with ADC input pin in MCU. The RP515x allows the CE2 pin to control the battery monitor's start and stop according to the sampling cycle from the ADC, reducing the power consumption of the entire system.

During the battery voltage monitoring, waiting time is needed, preferable $t_w \geq 10\text{ms}$, for the CE2 pin to gain stable V_{BM} .

TYPICAL CHARACTERISTICS

Note: Typical Characteristics are intended to be used as reference data; they are not guaranteed.

1) Quiescent Current vs Temperature

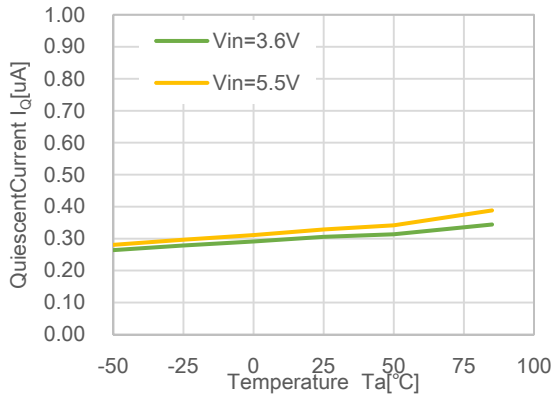

2) Standby Current vs Temperature

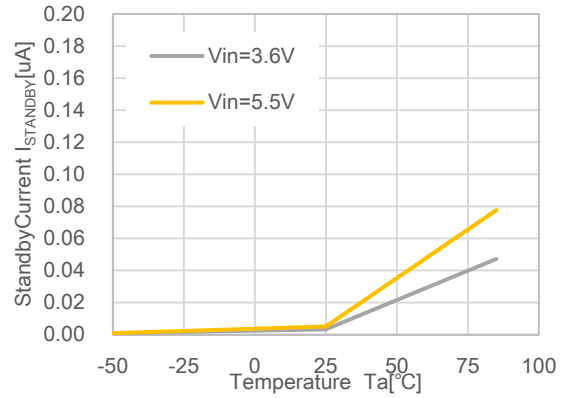

3) Output Voltage vs Temperature

RP515x181x, V_{IN}=3.6V

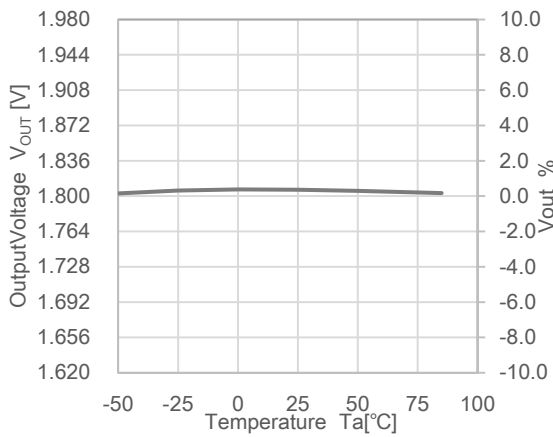

4) Efficiency vs Output Current

RP515x121x, Ta=25°C

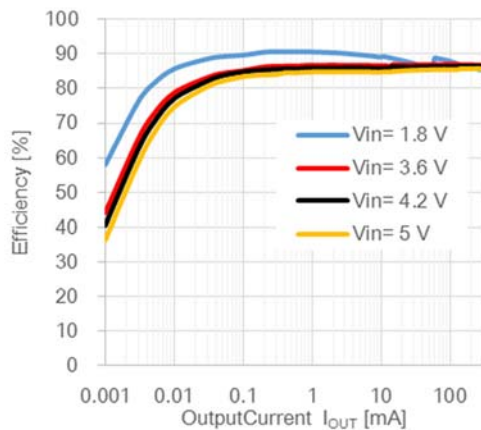

RP515x181x, Ta=25°C

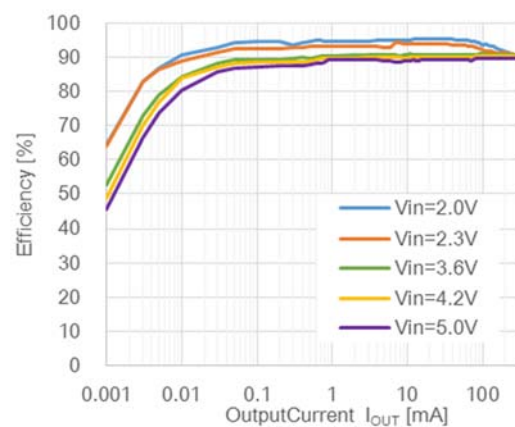

RP515x

No.EA-505-190328

RP515x331x, Ta=25°C

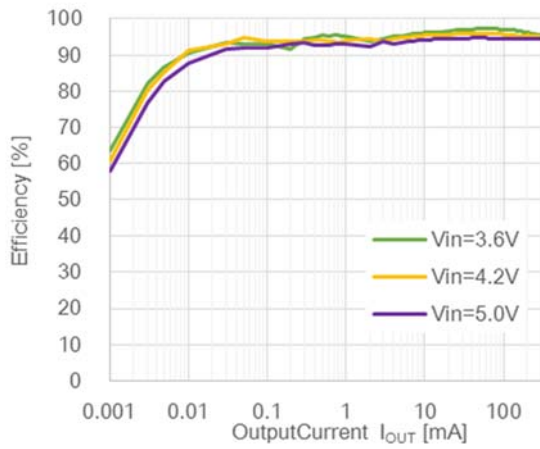

5) Output Voltage vs Output Current

RP515x121x, Ta=25°C

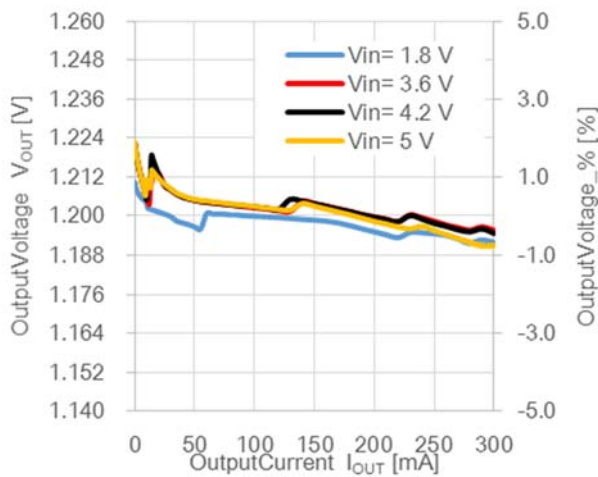

RP515x181x, Ta=25°C

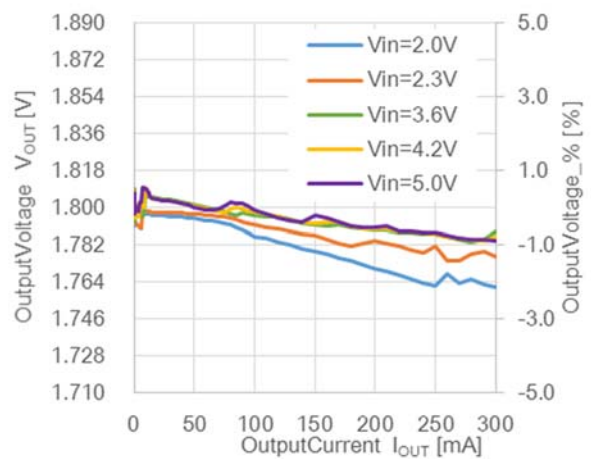

RP515x331x, Ta=25°C

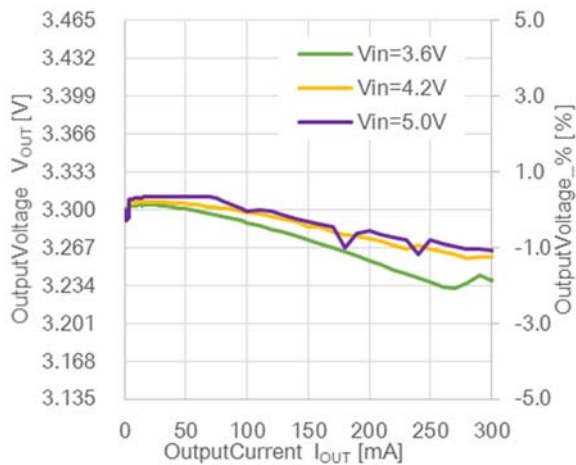

6) Ripple Voltage vs Output Current
 RP515x121x, Ta=25°C

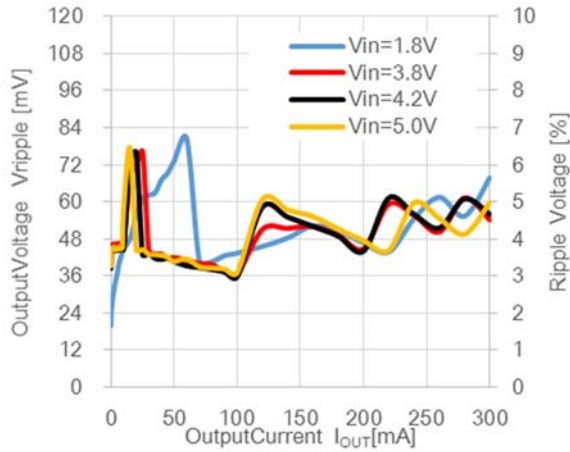

RP515x181x, Ta=25°C

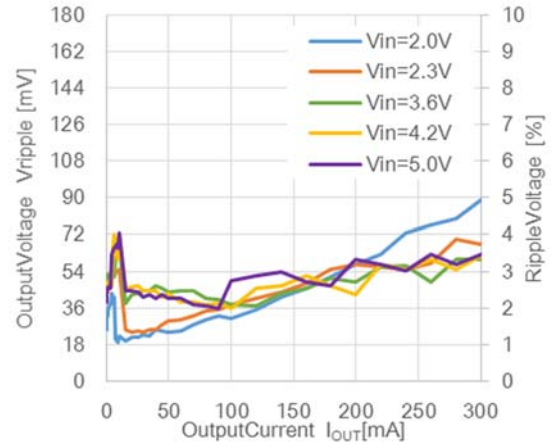

RP515x331x, Ta=25°C

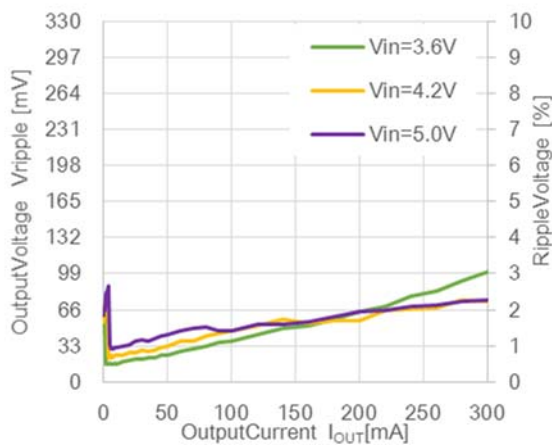

7) Switching Frequency vs Output Current
 RP515x121x, Ta=25°C

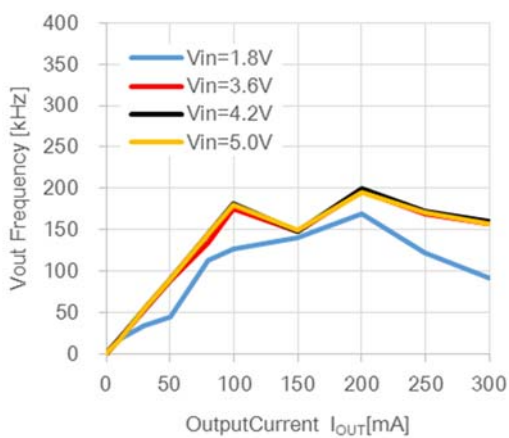

RP515x181x, Ta=25°C

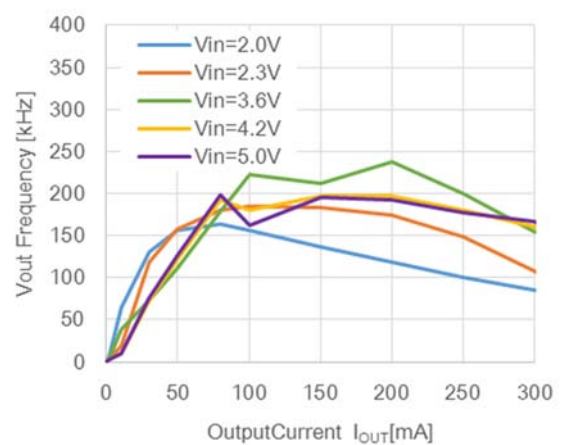

RP515x

No.EA-505-190328

RP515x331x, Ta=25°C

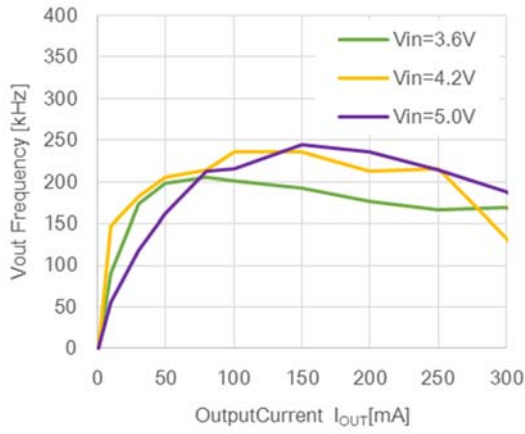

8) Load Transient Response

RP515x181x, $V_{IN}=3.6V$, Ta=25°C

$I_{OUT}=10\mu A \rightarrow 100mA$

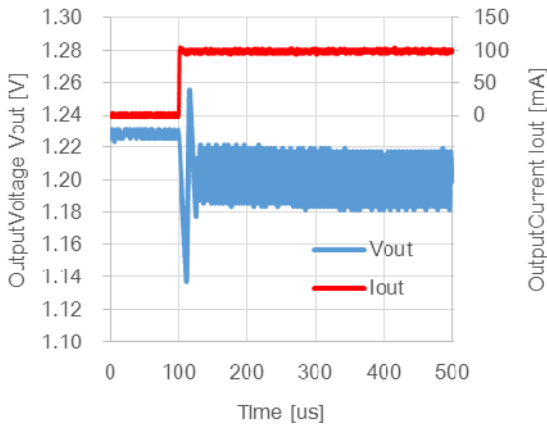

$I_{OUT}=100mA \rightarrow 10\mu A$

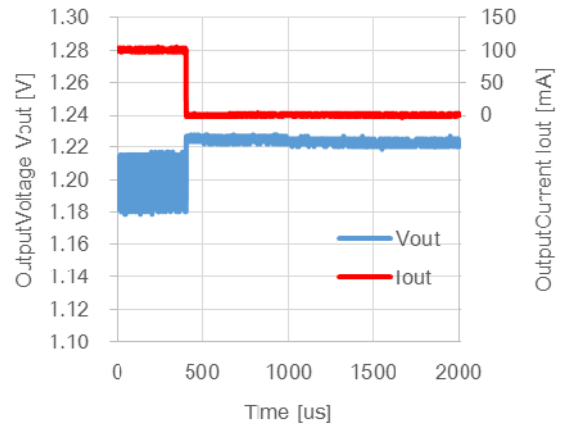

$I_{OUT}=10\mu A \rightarrow 100mA \rightarrow 10\mu A$

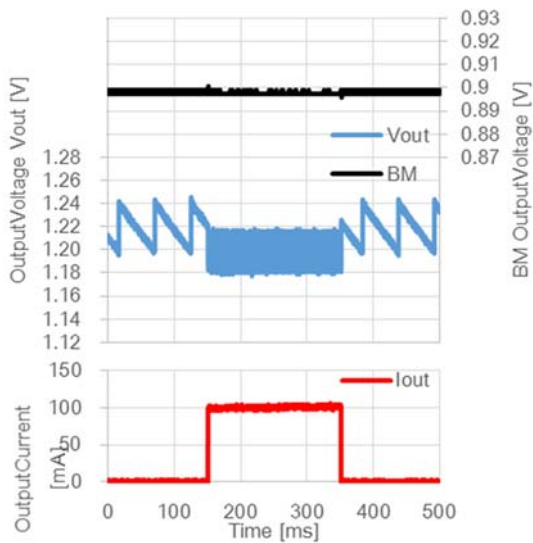

9) Soft Start Time

RP515x181x, $T_a=25^{\circ}\text{C}$

$V_{IN}=V_{CE1}=0\text{V}\rightarrow 3.6\text{V}$, $\Delta t=10\mu\text{s}$

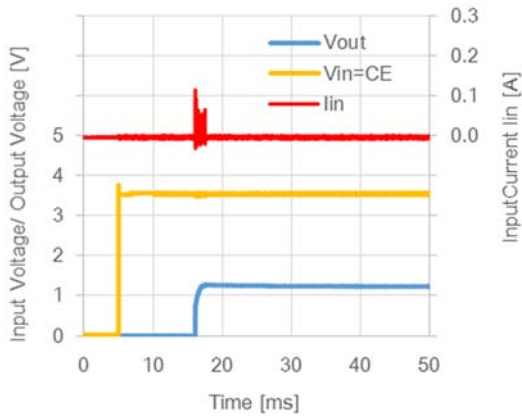

$V_{IN}=3.6\text{V}$, $V_{CE1}=0\text{V}\rightarrow 3.6\text{V}$, $\Delta t=10\mu\text{s}$

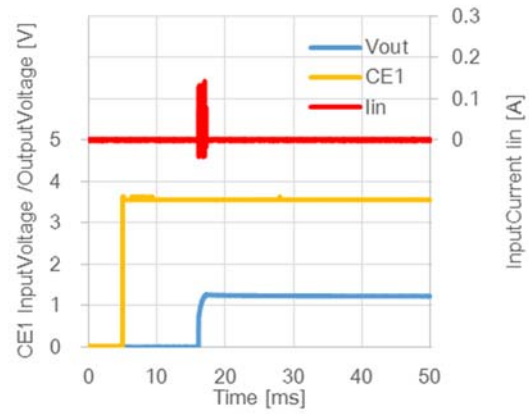

$I_{OUT}=300\text{mA}$

$V_{IN}=V_{CE1}=0\text{V}\rightarrow 3.6\text{V}$, $\Delta t=10\mu\text{s}$

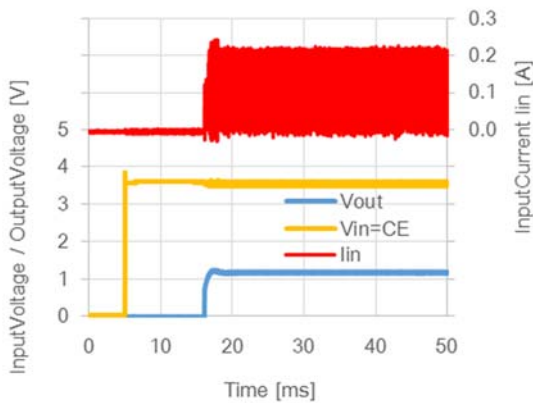

$V_{IN}=3.6\text{V}$, $V_{CE1}=0\text{V}\rightarrow 3.6\text{V}$, $\Delta t=10\mu\text{s}$

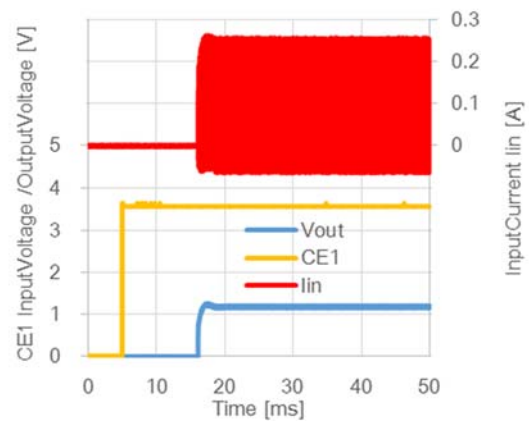

10) BM Supply Current vs Temperature (C_{OUT2} = Ceramic $0.1\mu\text{F}$, $V_{IN}=3.6\text{V}$)

RP515xxx3x

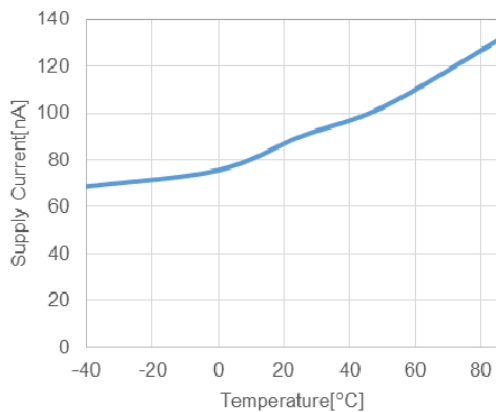

RP515xxx4x

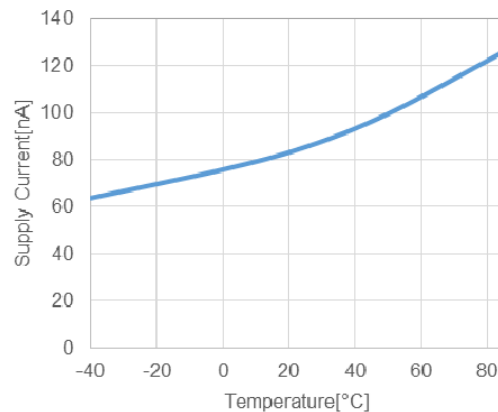

RP515x

No.EA-505-190328

11) BM Supply Current vs Input Voltage (C_{OUT2} = Ceramic 0.1 μ F, T_a = 25 $^{\circ}$ C)

RP515xxx3x

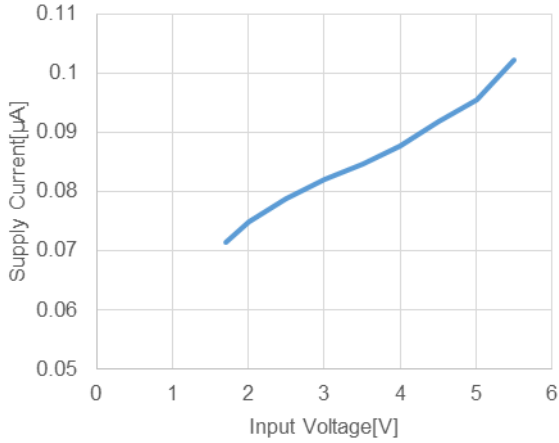

RP515xxx4x

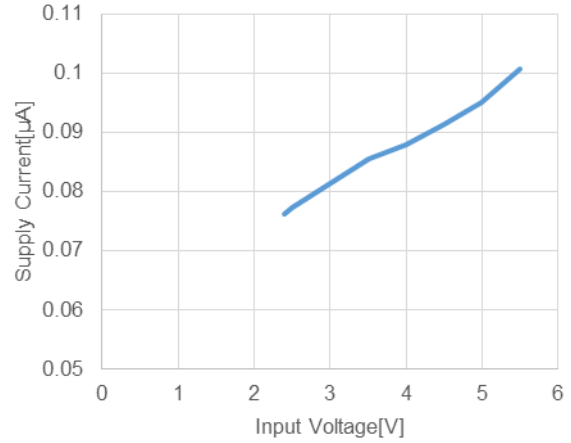

12) BM Output Voltage vs Input Voltage (C_{OUT2} = Ceramic 0.1 μ F, V_{IN} =3.6V)

RP515xxx3x

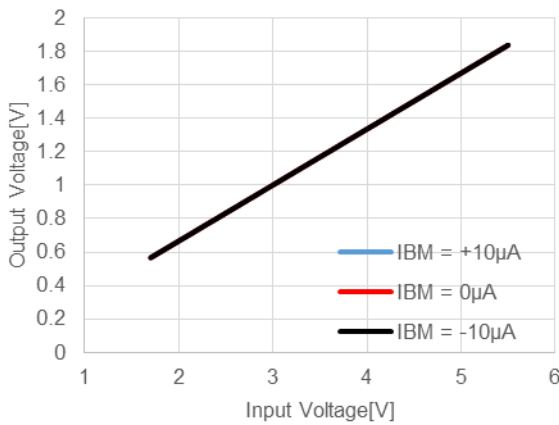

RP515xxx4x

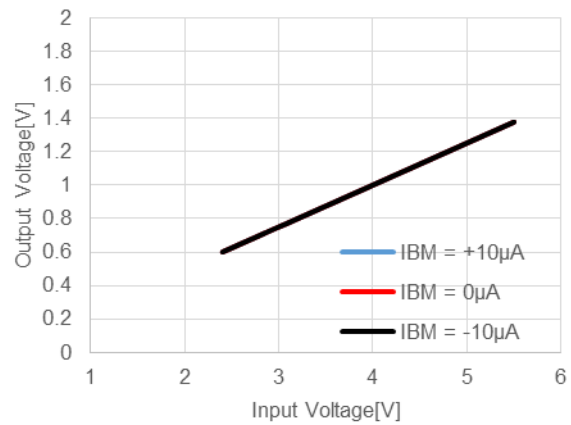

13) BM Output Voltage vs Temperature (C_{OUT2} = Ceramic 0.1 μ F, T_a = 25 $^{\circ}$ C)

RP515xxx3x

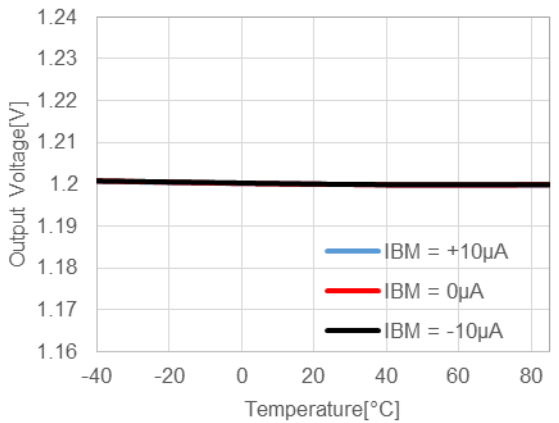

RP515xxx4x

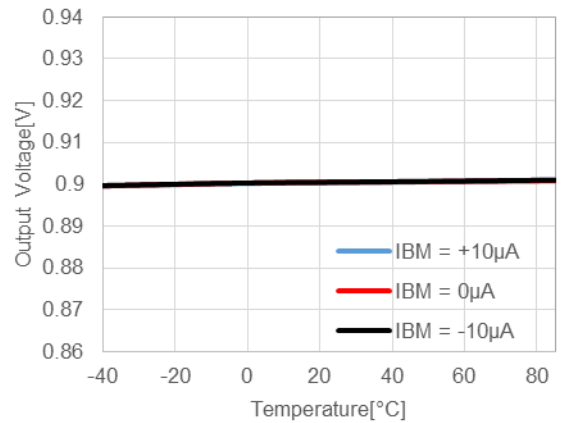

14) BM CE2 Rising / Falling (C_{OUT2} = Ceramic 0.1 μ F, 0.22 μ F, T_a = 25°C)

RP515xxx3x, V_{IN} =3.6V, V_{CE2} = 0V \Leftrightarrow 3.6V

RP515xxx4x, V_{IN} =3.6V, V_{CE2} = 0V \Leftrightarrow 3.6V

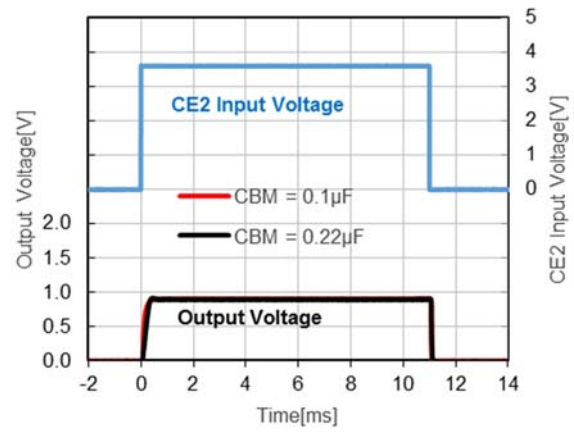
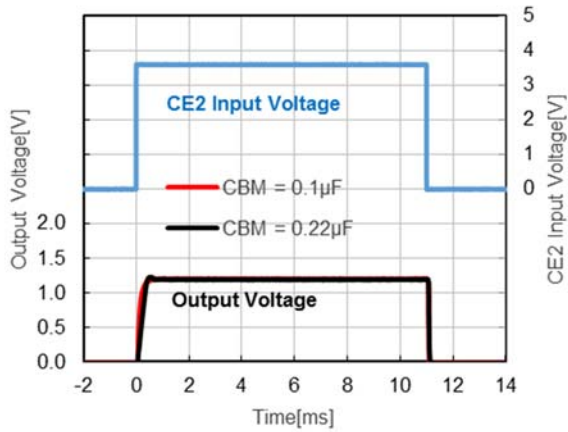

RP515xxx3x, V_{IN} =5.5V, V_{CE2} = 0V \Leftrightarrow 5.5V

RP515xxx4x, V_{IN} =5.5V, V_{CE2} = 0V \Leftrightarrow 5.5V

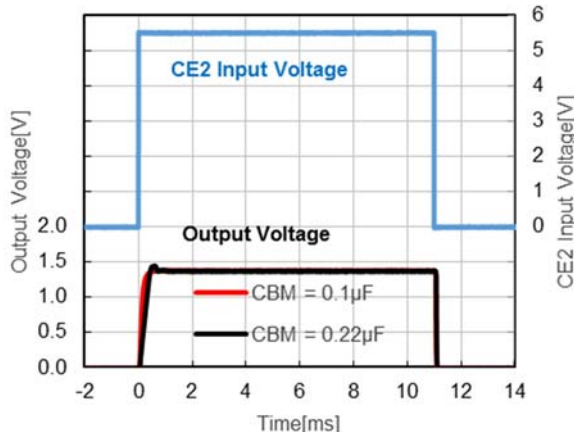
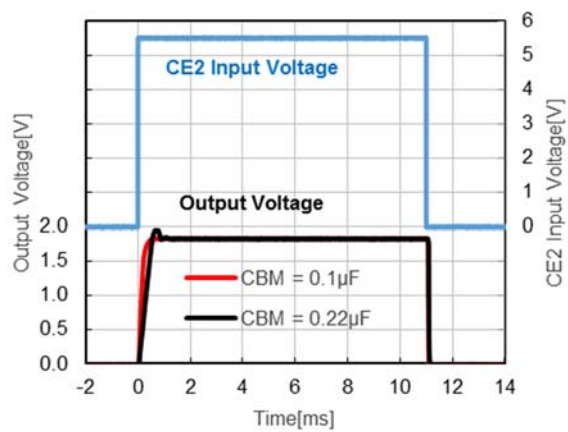

RP515x

No.EA-505-190328

Test Circuit

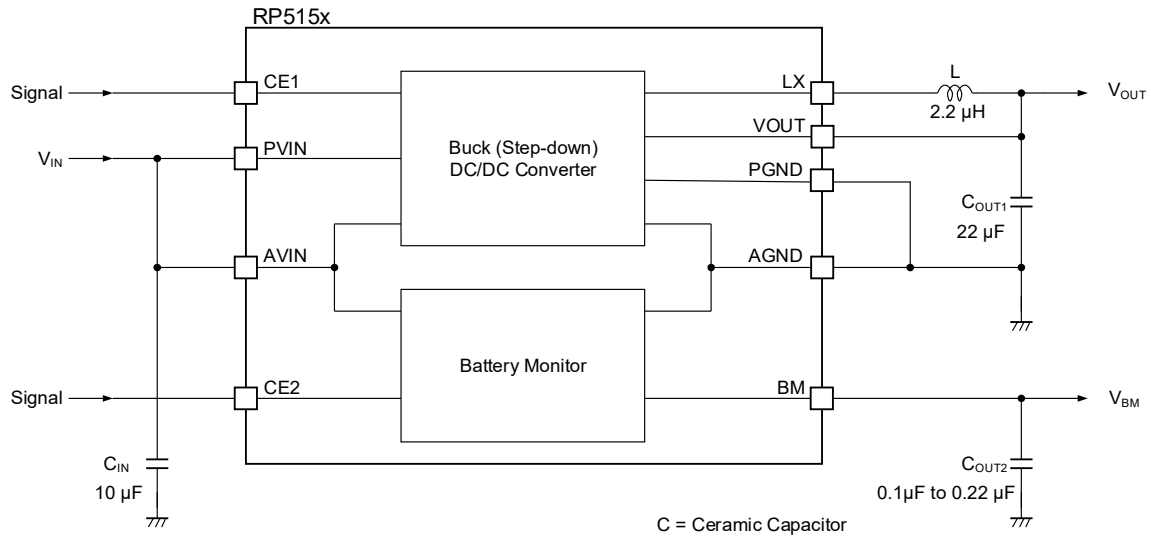

Test Circuit of Typical Characteristics

Measurement Components of Typical Characteristics

Symbol	Capacitance	Manufacture	Parts number
C _{IN}	10µF	Murata	GRM155R60J106ME44
C _{OUT1}	22µF	TAIYO YUDEN	JMK107BBJ226MA-T
C _{OUT2}	0.1µF	Murata	GRM155R61A104KA01D
L	2.2µH	TOKO	DFE201610P-2R2M

The power dissipation of the package is dependent on PCB material, layout, and environmental conditions. The following measurement conditions are based on JEDEC STD. 51-9.

Measurement Conditions

Item	Measurement Conditions
Environment	Mounting on Board (Wind Velocity = 0 m/s)
Board Material	Glass Cloth Epoxy Plastic (Four-Layer Board)
Board Dimensions	101.5 mm x 114.5 mm x 1.6 mm
Copper Ratio	Outer Layer (First Layer): 60% Inner Layers (Second and Third Layers): 100% Outer Layer (Fourth Layer): 60%

Measurement Result

(Ta = 25°C, Tjmax = 125°C)

Item	Measurement Result
Power Dissipation	1090 mW
Thermal Resistance (θ_{ja})	$\theta_{ja} = 91^\circ\text{C/W}$

θ_{ja} : Junction-to-Ambient Thermal Resistance

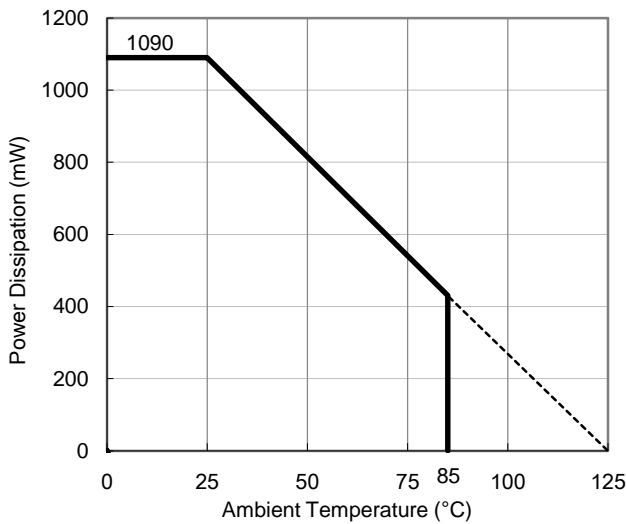

Power Dissipation vs. Ambient Temperature

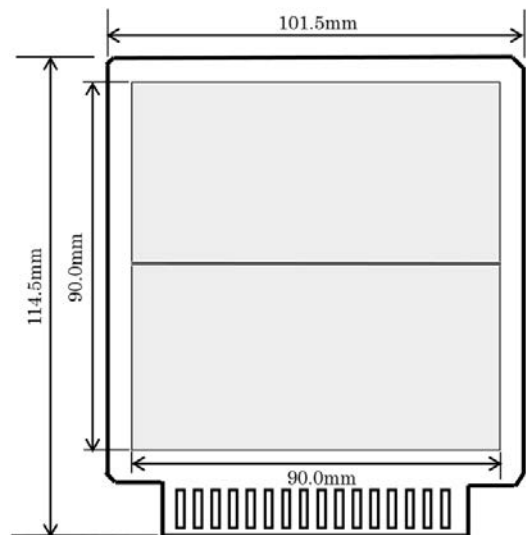

Measurement Board Pattern

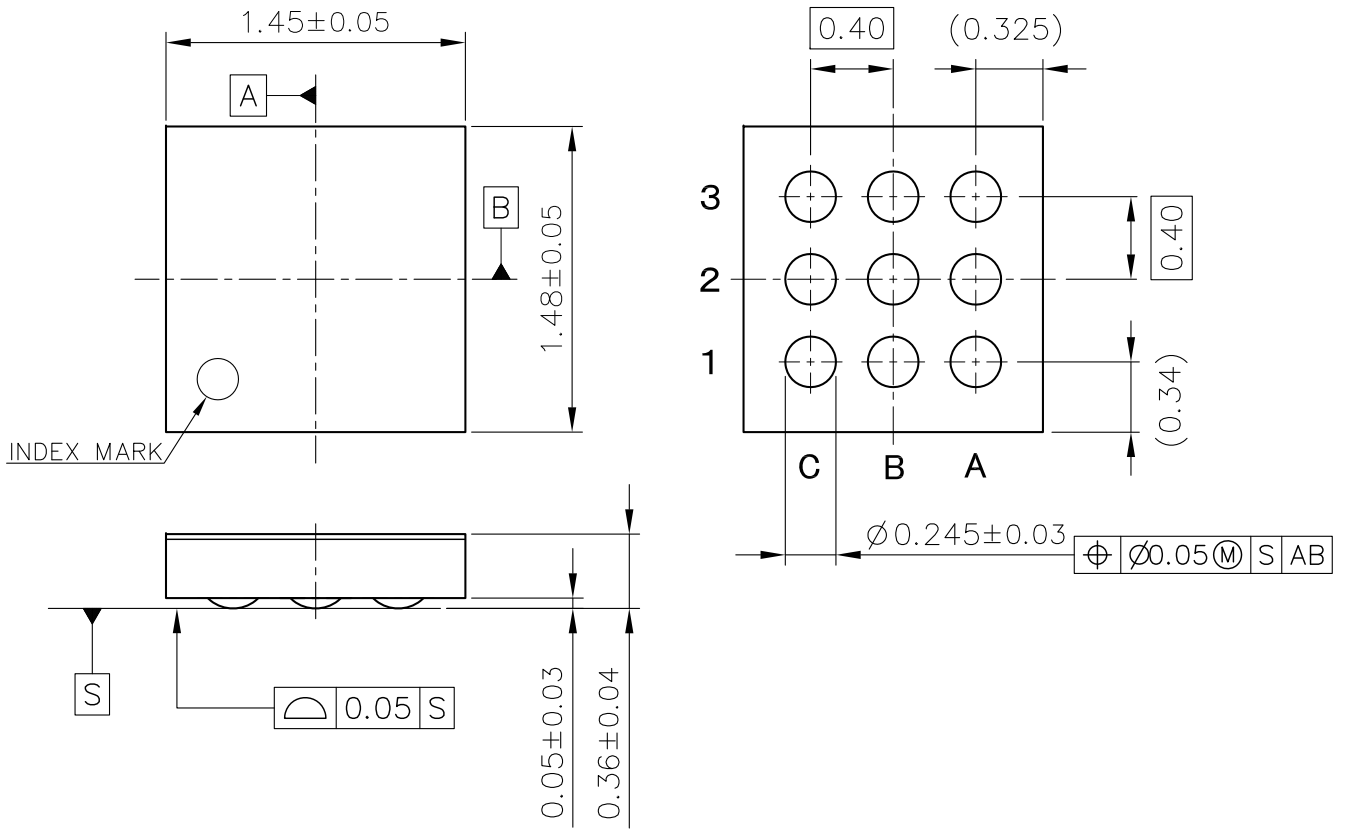

WLCSP-9-P2 Package Dimensions (Unit: mm)

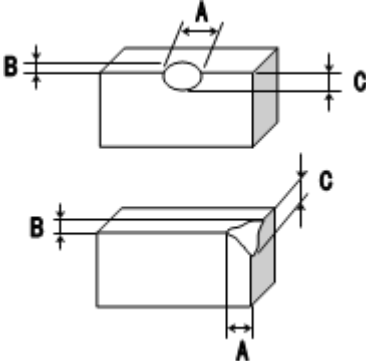
No.	Inspection Items	Inspection Criteria	Figure
1	Package chipping	$A \geq 0.2\text{mm}$ is rejected $B \geq 0.2\text{mm}$ is rejected $C \geq 0.2\text{mm}$ is rejected And, Package chipping to Si surface and to bump is rejected.	
2	Si surface chipping	$A \geq 0.2\text{mm}$ is rejected $B \geq 0.2\text{mm}$ is rejected $C \geq 0.2\text{mm}$ is rejected But, even if $A \geq 0.2\text{mm}$, $B \leq 0.1\text{mm}$ is acceptable.	
3	No bump	No bump is rejected.	
4	Marking miss	To reject incorrect marking, such as another product name marking or another lot No. marking.	
5	No marking	To reject no marking on the package.	
6	Reverse direction of marking	To reject reverse direction of marking character.	
7	Defective marking	To reject unreadable marking. (Microscope: X15/ White LED/ Viewed from vertical direction)	
8	Scratch	To reject unreadable marking character by scratch. (Microscope: X15/ White LED/ Viewed from vertical direction)	
9	Stain and Foreign material	To reject unreadable marking character by stain and foreign material. (Microscope: X15/ White LED/ Viewed from vertical direction)	

The power dissipation of the package is dependent on PCB material, layout, and environmental conditions. The following measurement conditions are based on JEDEC STD. 51-7.

Measurement Conditions

Item	Measurement Conditions
Environment	Mounting on Board (Wind Velocity = 0 m/s)
Board Material	Glass Cloth Epoxy Plastic (Four-Layer Board)
Board Dimensions	76.2 mm × 114.3 mm × 0.8 mm
Copper Ratio	Outer Layer (First Layer): Less than 95% of 50 mm Square Inner Layers (Second and Third Layers): Approx. 100% of 50 mm Square Outer Layer (Fourth Layer): Approx. 100% of 50 mm Square
Through-holes	φ 0.3 mm × 30 pcs

Measurement Result

(Ta = 25°C, Tjmax = 125°C)

Item	Measurement Result
Power Dissipation	2500 mW
Thermal Resistance (θ_{ja})	$\theta_{ja} = 39^{\circ}\text{C/W}$
Thermal Characterization Parameter (ψ_{jt})	$\psi_{jt} = 11^{\circ}\text{C/W}$

θ_{ja} : Junction-to-Ambient Thermal Resistance

ψ_{jt} : Junction-to-Top Thermal Characterization Parameter

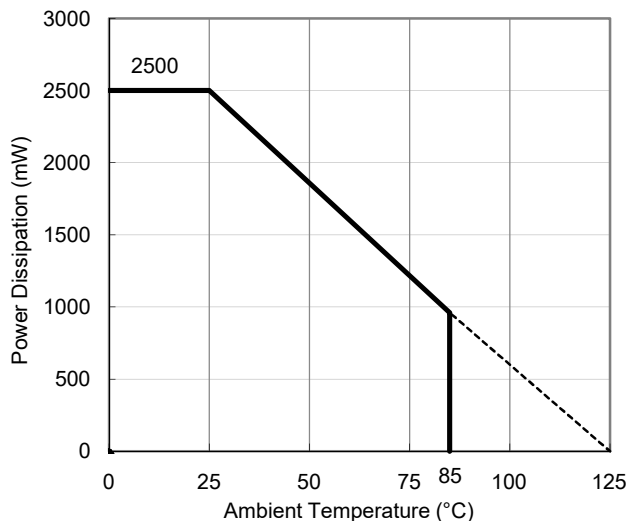

Power Dissipation vs. Ambient Temperature

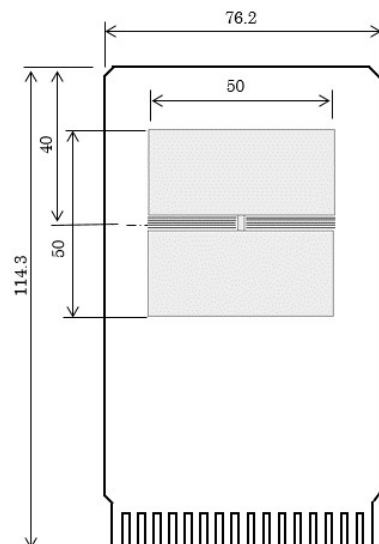

Measurement Board Pattern

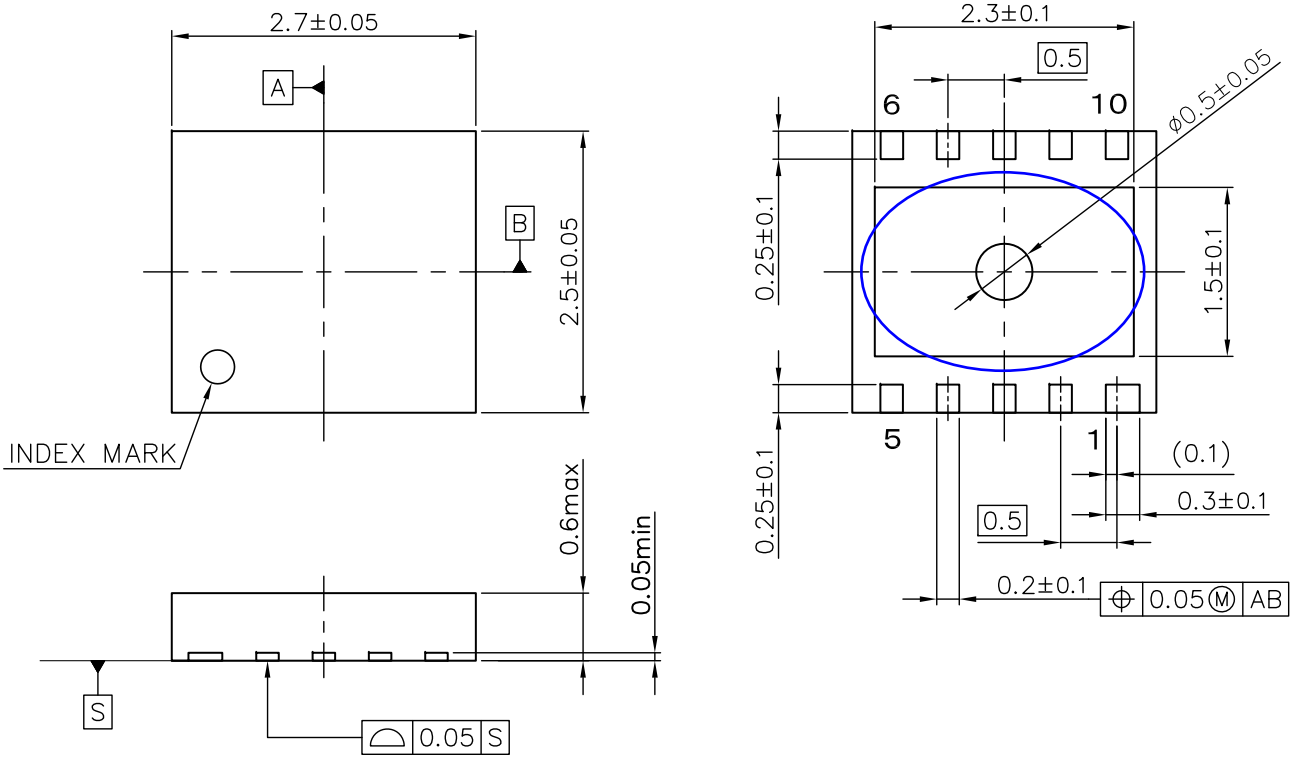

DFN(PL)2527-10 Package Dimensions (mm)

* The tab on the bottom of the package shown by blue circle is a substrate potential (GND). It is recommended that this tab be connected to the ground plane on the board but it is possible to leave the tab floating.



1. The products and the product specifications described in this document are subject to change or discontinuation of production without notice for reasons such as improvement. Therefore, before deciding to use the products, please refer to our sales representatives for the latest information thereon.
2. The materials in this document may not be copied or otherwise reproduced in whole or in part without prior written consent of our company.
3. Please be sure to take any necessary formalities under relevant laws or regulations before exporting or otherwise taking out of your country the products or the technical information described herein.
4. The technical information described in this document shows typical characteristics of and example application circuits for the products. The release of such information is not to be construed as a warranty of or a grant of license under our company's or any third party's intellectual property rights or any other rights.
5. The products listed in this document are intended and designed for use as general electronic components in standard applications (office equipment, telecommunication equipment, measuring instruments, consumer electronic products, amusement equipment etc.). Those customers intending to use a product in an application requiring extreme quality and reliability, for example, in a highly specific application where the failure or misoperation of the product could result in human injury or death (aircraft, spacevehicle, nuclear reactor control system, traffic control system, automotive and transportation equipment, combustion equipment, safety devices, life support system etc.) should first contact us.
6. We are making our continuous effort to improve the quality and reliability of our products, but semiconductor products are likely to fail with certain probability. In order to prevent any injury to persons or damages to property resulting from such failure, customers should be careful enough to incorporate safety measures in their design, such as redundancy feature, fire containment feature and fail-safe feature. We do not assume any liability or responsibility for any loss or damage arising from misuse or inappropriate use of the products.
7. Anti-radiation design is not implemented in the products described in this document.
8. The X-ray exposure can influence functions and characteristics of the products. Confirm the product functions and characteristics in the evaluation stage.
9. WLCSP products should be used in light shielded environments. The light exposure can influence functions and characteristics of the products under operation or storage.
10. There can be variation in the marking when different AOI (Automated Optical Inspection) equipment is used. In the case of recognizing the marking characteristic with AOI, please contact our sales or our distributor before attempting to use AOI.
11. Please contact our sales representatives should you have any questions or comments concerning the products or the technical information.



Nisshinbo Micro Devices Inc.

Official website

<https://www.nisshinbo-microdevices.co.jp/en/>

Purchase information

<https://www.nisshinbo-microdevices.co.jp/en/buy/>

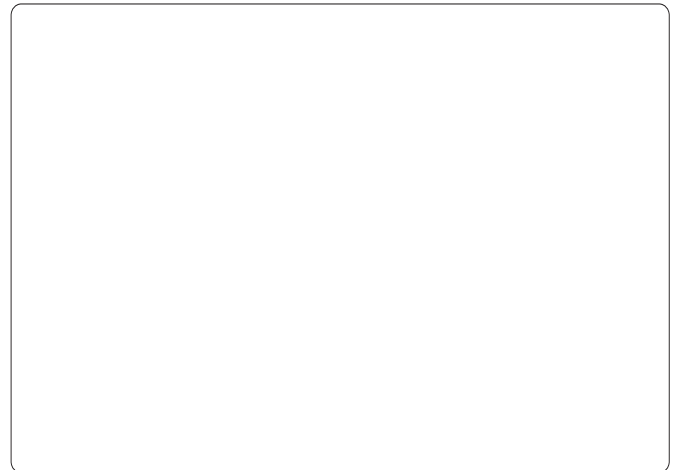

Mouser Electronics

Authorized Distributor

Click to View Pricing, Inventory, Delivery & Lifecycle Information:

[Nisshinbo Micro Devices:](#)

[RP515K334D-TR](#) [RP515K254C-TR](#) [RP515K183C-TR](#) [RP515K153C-TR](#)