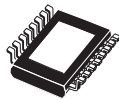

8-channel LED driver with direct switch control

 HTSSOP16
(Exposed pad)

Features

- 8 constant current output channels controlled by four switch inputs
- Output current: from 5 mA to 100 mA
- Current programmable through external resistor
- Supply voltage: 3 V to 5.5 V
- Thermal shutdown
- 20 V current generators rated voltage
- Available in high thermal efficiency TSSOP exposed pad package
- ESD protection 2.0 kV HBM, 100 V MM

Applications

- White and RGB lighting and Backlight
 - Appliance display and human interface
 - Industrial display and function indicator
 - Architectural Lighting

Description

The **LED8102S** is a monolithic, low voltage, 8 low-side channels. The **LED8102S** guarantees up to 20 V output driving capability allowing users to connect several LEDs in series. In the output stage, 8 regulated current sources provide from 5 mA to 100 mA constant current to drive the LEDs. Current is programmed through a single external resistor.

LED8102S is equipped with a thermal management that protects the device forcing it in shutdown (typically: power-off at 170 °C with 15 °C hysteresis to restart). The thermal protection switches OFF only the output channels.

The operative supply voltage range is between 3 V and 5.5 V. Outputs control is provided by four switch inputs, proving an on/off toggle action. On all active outputs LEDs brightness can be adjusted with a global PWM signal applied to the output enable pin (\overline{OE}). Outputs can be connected in parallel, or left unconnected if not used, as required by application.

Maturity status link

[LED8102S](#)

Device summary

Order code	LED8102SXTR
Package	HTSSOP16
Packing	2500 parts per reel

1 Pin description

Figure 1. Pinout for HTSSOP16

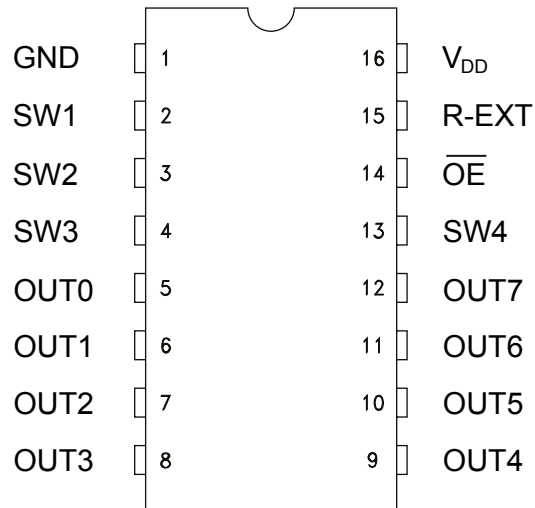
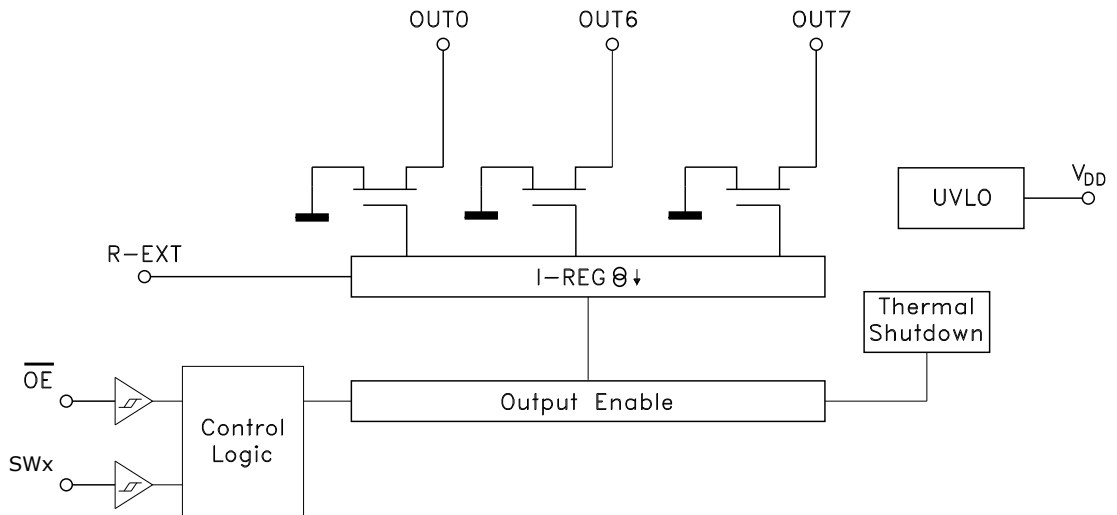

Table 1. Pin description

HTSSOP16	Symbol	Name and function
1	GND	Ground terminal
2	SW1	Switch input 1 to enable OUT0 and OUT1 simultaneously
3	SW2	Switch input 2 to enable OUT2 and OUT3 simultaneously
4	SW3	Switch input 3 to enable OUT4 and OUT5 simultaneously
5-12	OUT0-OUT7	Output terminals
13	SW4	Switch input 4 to enable OUT6 and OUT7 simultaneously
14	\overline{OE}	Global PWM brightness control input terminal (it must be connected to GND if not used)
15	R-EXT	Terminal for external resistor for constant current programming
16	V _{DD}	Supply voltage terminal

2 Simplified internal block diagram

Figure 2. LED8102S simplified block diagram



3 Absolute maximum ratings

Stressing the device above the ratings listed in the table below may cause permanent damage to the device. These are stress ratings only and operation of the device at these or any other conditions above those indicated in the Operating sections of this specification is not implied. Exposure to Absolute Maximum Rating conditions for extended periods may affect device reliability.

Table 2. Absolute maximum ratings

Symbol	Parameter	Value	Unit
V_{DD}	Supply voltage	0 to 7	V
V_O	Output voltage	- 0.5 to 20	V
I_O	Output current	100	mA
V_I	Input voltage	-0.4 to V_{DD}	V
I_{GND}	GND terminal current	800	mA
ESD	Electrostatic Discharge Protection HBM Human Body Model	± 2	KV
	Electrostatic Discharge Protection MM Machine Model	100	V

3.1 Thermal characteristics

Table 3. Thermal characteristics

Symbol	Parameter	Value	Unit
T_{OPR}	Operative junction temperature range	-40 to +150	°C
T_{STG}	Storage ambient temperature range	-55 to +150	
$R_{thj-amb}$	Thermal resistance Junction-Ambient (HTSSOP16) ⁽¹⁾	37.5	°C/W

1. The exposed pad should be soldered directly to the PCB to realize the thermal benefits

4 Electrical characteristics

$V_{DD} = 5\text{ V}$, $T_j = 25\text{ °C}$, $R_{EXT} = 980\ \Omega$, $V_O = 0.85\text{ V}$ unless otherwise specified.

Table 4. Electrical characteristics

Symbol	Parameter	Conditions	Min.	Typ.	Max.	Unit
V_{DD}	Supply voltage		3.0	-	5.5	V
V_{UVLO}	UVLO threshold (rising)			2.7	2.9	
	UVLO threshold (falling)		2.1	2.3		
H_{YUVLO}	UVLO hysteresis			0.4		
V_O	Output voltage ^{(1) (2)}	OUT0 – OUT7	0.85	-	19	
V_{IH}	SWx / \overline{OE} input voltage		$0.8V_{DD}$	-	V_{DD}	K Ω
V_{IL}			GND	-	$0.2V_{DD}$	
R_{UP}	Pull-up resistor for \overline{OE} pin		-	300	-	K Ω
R_{DW}	Pull-down resistor for SWx pins		-	310	-	
R_{EXT}	External current set-up resistance		0.19	-	3.9	
$I_{DD(OFF1)}$	Supply current (OFF)	OUT0 to 7 = OFF	-	7	8	mA
$I_{DD(OFF2)}$		$R_{EXT} = 190\ \Omega$ OUT0 to 7 = OFF	-	14	16	
$I_{DD(ON)}$		$R_{EXT} = 190\ \Omega$ $V_O = 1.4\text{ V}$ OUT0 to 7 = ON	-	14	16	
$\%/dV_O$	Output current vs. output voltage regulation ^{(1) (3)}	V_O from 1 V to 3 V;	-	0.1	-	%/V
$\%/dV_{DD}$	Output current vs. supply voltage regulation ^{(1) (4)}	V_{DD} from 3 V to 5.5 V	-	1	-	
ΔI_{OL}	Output current precision: chip to chip ⁽¹⁾	$V_O = 0.3\text{ V}$; $R_{EXT} = 3.9\text{ K}\Omega$	-	-	± 6	%
ΔI_{OL1}	Output current precision: channel to channel ^{(1) (5)}	$V_O = 0.3\text{ V}$	-	± 1.5	± 4	%
ΔI_{OL2}		$V_O = 1.4\text{ V}$; $R_{EXT} = 190\ \Omega$	-	± 1.2	± 4	
I_{Oleak}	Single output leakage current	$V_O = 19\text{ V}$ OUTn = OFF	-	0.5	2	μA
T_{sd}	Thermal shutdown ⁽⁶⁾			170		$^{\circ}\text{C}$
T_{sd_hys}	Thermal shutdown hysteresis ⁽⁶⁾			15		$^{\circ}\text{C}$

1. Test with just one output ON.

2. Minimum regulation voltage @ $I_O = 50\text{ mA}$.

$$3. \Delta(\%/V) = \frac{(I_{on@V_{on}3.0V}) - (I_{on@V_{on}1.0V})}{(I_{on@V_{on}1.0V})} \times \frac{100}{3-1}$$

$$4. \Delta(\%/V) = \frac{(I_{on@V_{DD}=5.5V}) - (I_{on@V_{DD}=3.0V})}{(I_{on@V_{DD}=3.0V})} \times \frac{100}{5.5-1}$$

5. $((I_{On} - I_{Oavg0-7}) / I_{Oavg0-7}) \times 100$.

6. Not tested in production.

5 Switching characteristics

$V_{DD} = 5\text{ V}$, $T_j = 25\text{ }^\circ\text{C}$, $I_O = 50\text{ mA}$, $R_L = 60\text{ }\Omega$, $C_L = 10\text{ pF}$, $V_L = 5\text{ V}$, unless otherwise specified.

Table 5. Switching characteristics

Symbol	Parameter	Conditions	Min.	Typ.	Max.	Unit	
t_{PLH1}	SWx – OUTn (OE just “0”)	Propagation delay time (“L” to “H”)	$V_{DD} = 3.3\text{ V}$	-	220	-	ns
			$V_{DD} = 5\text{ V}$	-	200	-	
t_{PLH2}	- OUTn (SWx just “=1”)	Propagation delay time (“L” to “H”)	$V_{DD} = 3.3\text{ V}$	-	220	-	
			$V_{DD} = 5\text{ V}$	-	200	-	
t_{PHL1}	SWx – OUTn (OE just “0”)	Propagation delay time (“H” to “L”)	$V_{DD} = 3.3\text{ V}$	-	100	-	
			$V_{DD} = 5\text{ V}$	-	100	-	
t_{PHL2}	- OUTn (SWx just “=1”)	Propagation delay time (“H” to “L”)	$V_{DD} = 3.3\text{ V}$	-	90	-	
			$V_{DD} = 5\text{ V}$	-	100	-	
t_{ON}	OUTn Current rise time. Evaluated as OUTn falling time		$V_{DD} = 3.3\text{ V}$	-	430	-	
			$V_{DD} = 5\text{ V}$	-	400	-	
t_{OFF}	OUTn current fall time. Evaluated as OUTn rising time		$V_{DD} = 3.3\text{ V}$	-	430	-	
			$V_{DD} = 5\text{ V}$	-	400	-	
$t_{W(OE)}$	Output nable minimum pulse width		1	-	-	μs	

Figure 3. t_{ON} - t_{OFF} time evaluation

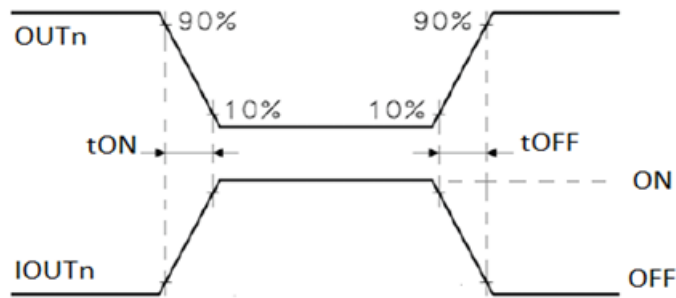
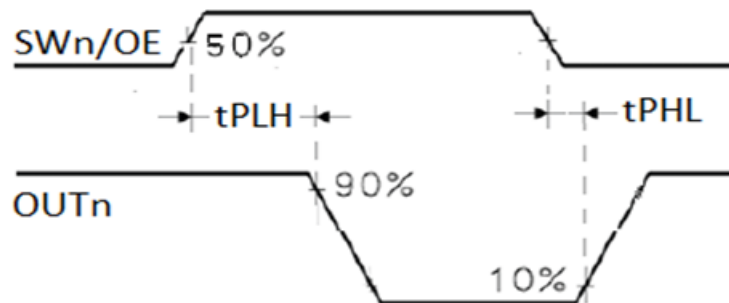

Figure 4. t_{PLH} - t_{PHL} time evaluation



6 Internal block diagram

Inputs \overline{OE} and SWx terminals have pull-up and pull-down connection respectively:

Figure 5. \overline{OE} Terminal

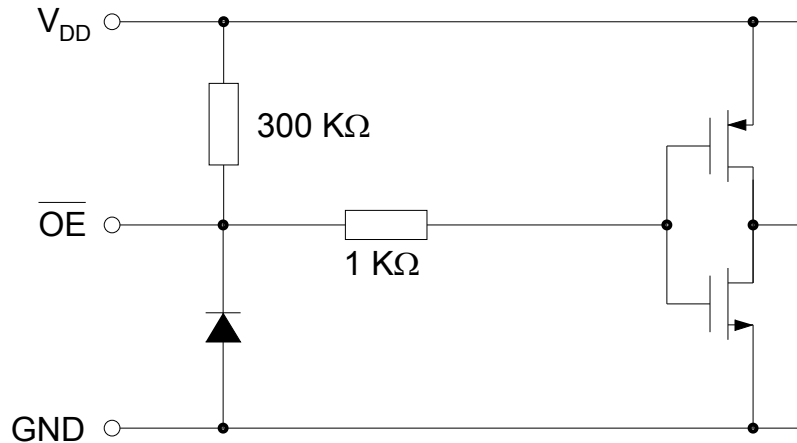
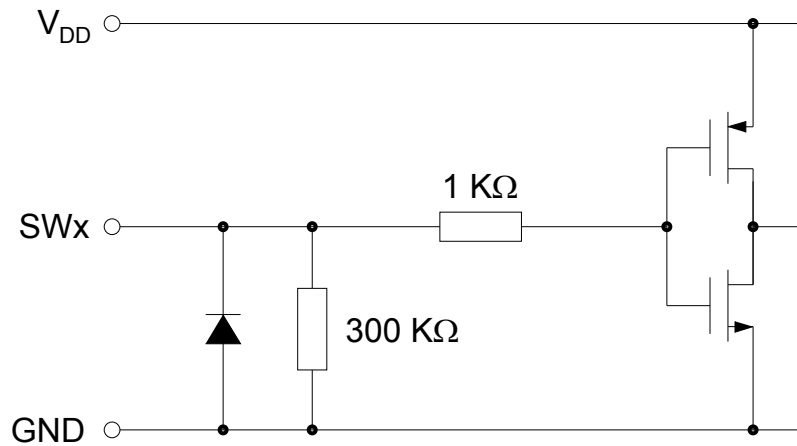

Figure 6. SWx Terminals



7 The switch output control

All switch inputs (SWx) are pulled down by a 300 kΩ. If the generic SWx pin is left floating or connected to GND or polarized at low logic level, the corresponding outputs will be in OFF condition. If SWx pin is connected to V_{DD} or polarized at high logic level, the corresponding outputs will be in ON condition. See below the complete truth table:

Table 6. Switches output control

Switch inputs	Outputs controlled (ON/OFF)
SW1	OUT0 and OUT1 simultaneously
SW2	OUT2 and OUT3 simultaneously
SW3	OUT4 and OUT5 simultaneously
SW4	OUT6 and OUT7 simultaneously

Table 7. Switches versus output truth table

SW4	SW3	SW2	SW1	OE	Out0	Out1	Out2	Out3	Out4	Out5	Out6	Out7
0	0	0	0	x	off	off	off	off	off	off	off	off
0	0	0	1	0	on	on	off	off	off	off	off	off
0	0	1	0	0	off	off	on	on	off	off	off	off
0	0	1	1	0	on	on	on	on	off	off	off	off
0	1	0	0	0	off	off	off	off	on	on	off	off
0	1	0	1	0	on	on	off	off	on	on	off	off
0	1	1	0	0	off	off	on	on	on	on	off	off
0	1	1	1	0	on	on	on	on	on	on	off	off
1	0	0	0	0	off	off	off	off	off	off	on	on
1	0	0	1	0	on	on	off	off	off	off	on	on
1	0	1	0	0	off	off	on	on	off	off	on	on
1	0	1	1	0	on	on	on	on	off	off	on	on
1	1	0	0	0	off	off	off	off	on	on	on	on
1	1	0	1	0	on	on	off	off	on	on	on	on
1	1	1	0	0	off	off	on	on	on	on	on	on
1	1	1	1	0	on	on	on	on	on	on	on	on
x	x	x	x	1	off	off	off	off	off	off	off	off

8 Typical characteristics

Figure 7. I_{SET} vs. drop-out voltage (V_{DROP} @ 25 °C)

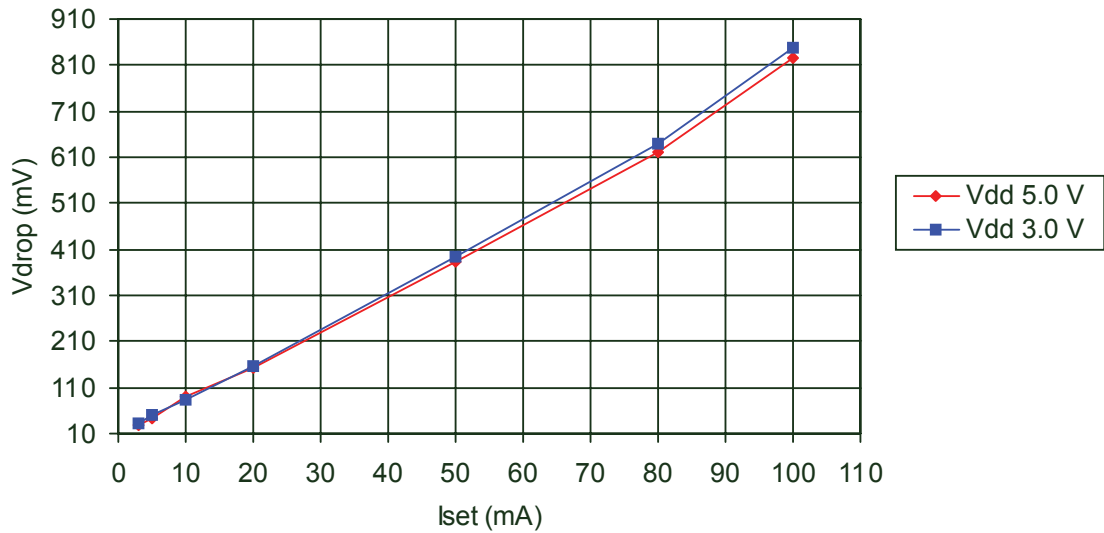
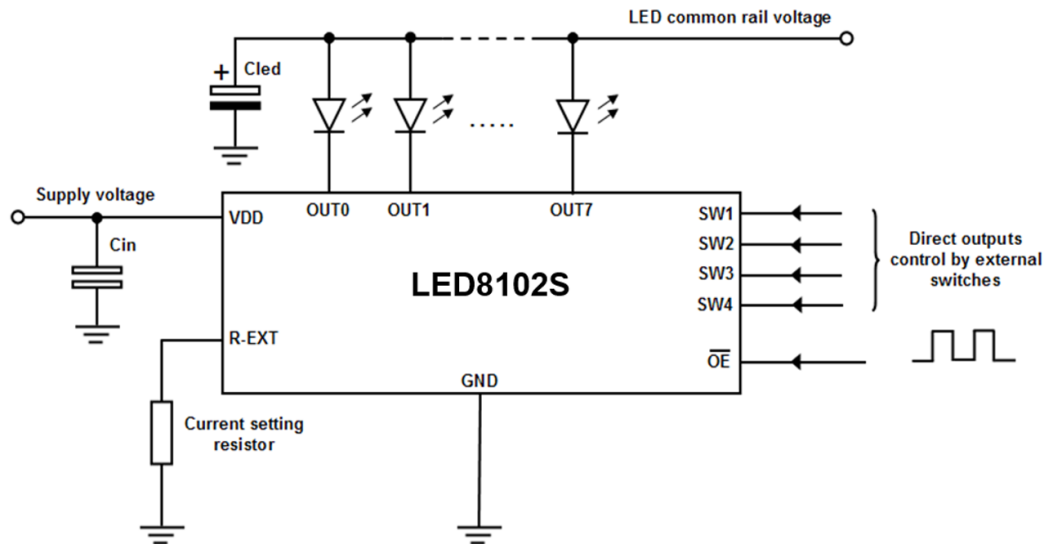

Table 8. Table settings

Vdd	Iset (mA)	Rext (Ω)	Vdrop min (mV)	Vdrop max (mV)	Vdrop AVG (mV)
3	5	3930	46.5	52.9	48.63
	10	1910	80.9	100	82.26
	20	963	150	161	157
	50	386	392	396	394.3
	80	241	636	646	640.3
	100	192	846	850	848
5	5	3930	40.8	41.7	41.16
	10	1910	80.1	105	89.2
	20	963	153	154	154
	50	386	379	386	382
	80	241	618	626	621
	100	192	825	830	827

9 Typical application

Figure 8. Typical application circuit



Typical application circuit

The figure above shows a typical application schematic for ALED8102S, Cled value depends on common rail voltage connection length and driver total output current, typically it is around 47 μF ; Cin is about 1 μF ; current setting resistor depends on outputs current set (ex. with $R_{\text{EXT}} = 386 \Omega \rightarrow I_{\text{O}} \approx 50 \text{ mA}$). The external programming resistor between R-EXT and GND should be connected as close as possible to the device.

To have proper device functionality it is strongly suggested to follow a correct power-up sequence: V_{DD} and V_{LED} power supplies must be provided simultaneously or at least, V_{DD} must be connected before V_{LED} to activate all internal digital control blocks earlier than LEDs power supply. If V_{LED} anticipates driver V_{DD} , this could result in a visible flash on connected LEDs (output stage undesired activation).

Device thermal management

The aim of this section is just to provide some recommendation that can be useful in designing the application PCB for a better power dissipation:

- To decrease the device working temperature it is necessary solder the package exposed pad to the board.
- For better thermal performances at least a 4 layers (e.g. 2S2P) PCB should be used.
- The copper area below the package thermal pad should be enlarged as much as possible also outside the package perimeter (using the package sides without pins)
- A reasonable number of vias must connect the copper area below the package to all available PCB layers especially just below the device package (e.g. 3x3 or 4x3 vias array) but also outside package perimeter. Smaller and closely spaced vias is a good solution. Best implementation is represented by copper filled vias.
- On each inner layers a copper area must be provided for dissipation (wider it's better, if possible at least 4 times or more the package dimensions). A good condition is to have at least a power layer as an entire copper area (e.g. GND layer)
- Traces for pins connection must be enlarged as much as layout constrains allow
- Several devices in power dissipation on the same board must be adequately spaced.

Figure 3 shows, once the maximum power dissipation is fixed, which ambient temperature range can be covered according to maximum junction temperature and package thermal resistance: 37.5 $^{\circ}\text{C}/\text{W}$ for HTSSOP16 on Jedec PCB (2S2P) and conditions. With same thermal resistance, figure 4 shows the junction temperature as a function of ambient temperature considering 1 W of power dissipation.

Figure 9. Power dissipation rating vs ambient temperature ($R_{th} = 37.5 \text{ }^\circ\text{C/W}$; $T_j = 125 \text{ }^\circ\text{C}$)

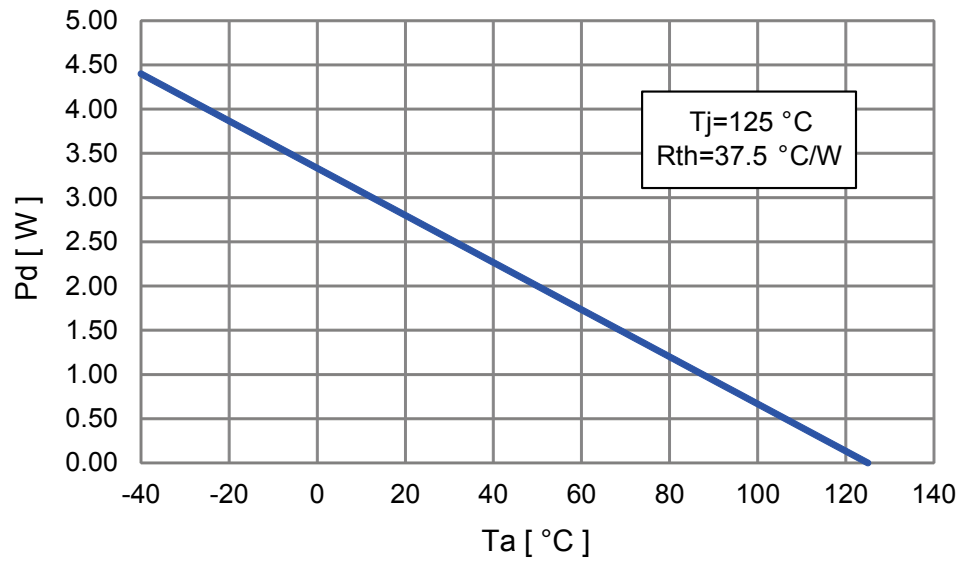
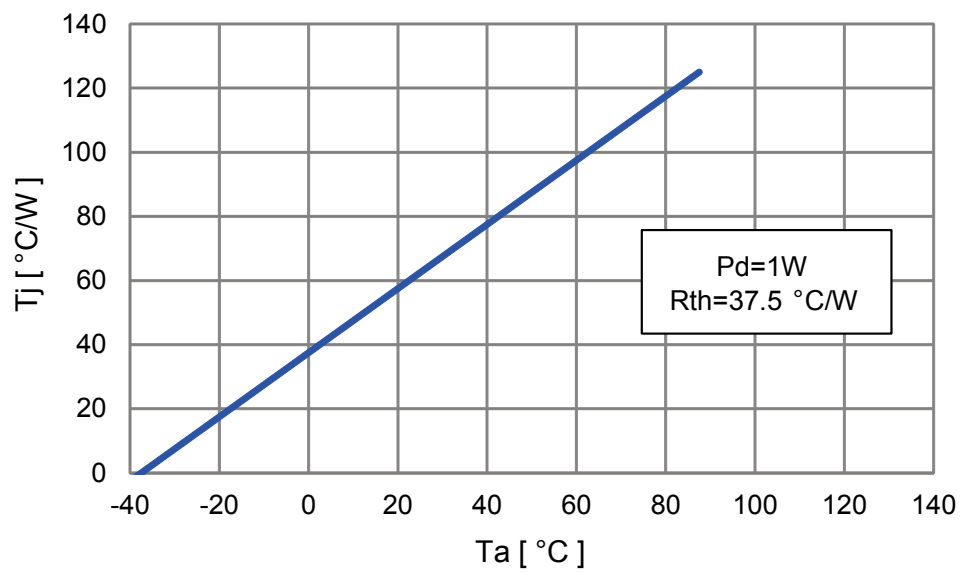

Figure 10. Junction temperature vs ambient temperature ($R_{th} = 37.5 \text{ }^\circ\text{C/W}$; $P_d = 1 \text{ W}$)



10 Package information

In order to meet environmental requirements, ST offers these devices in different grades of **ECOPACK** packages, depending on their level of environmental compliance. ECOPACK specifications, grade definitions and product status are available at: www.st.com. ECOPACK is an ST trademark.

10.1 HTSSOP16 package information

Figure 11. HTSSOP16 exposed pad package outline

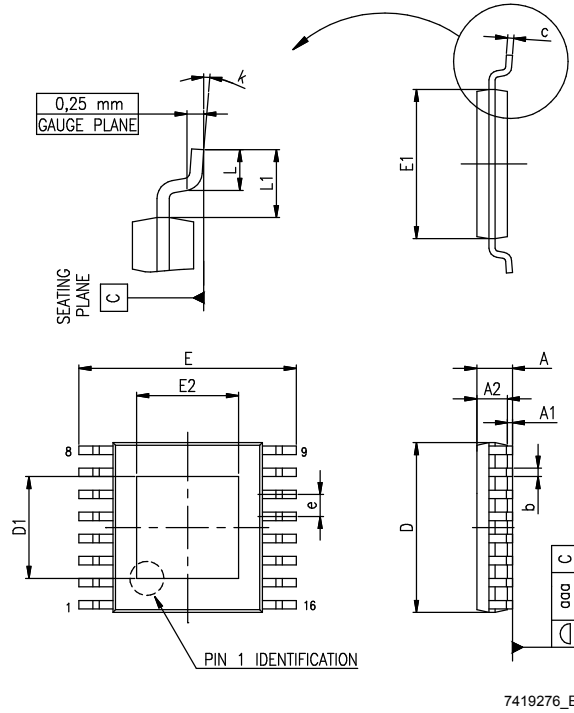
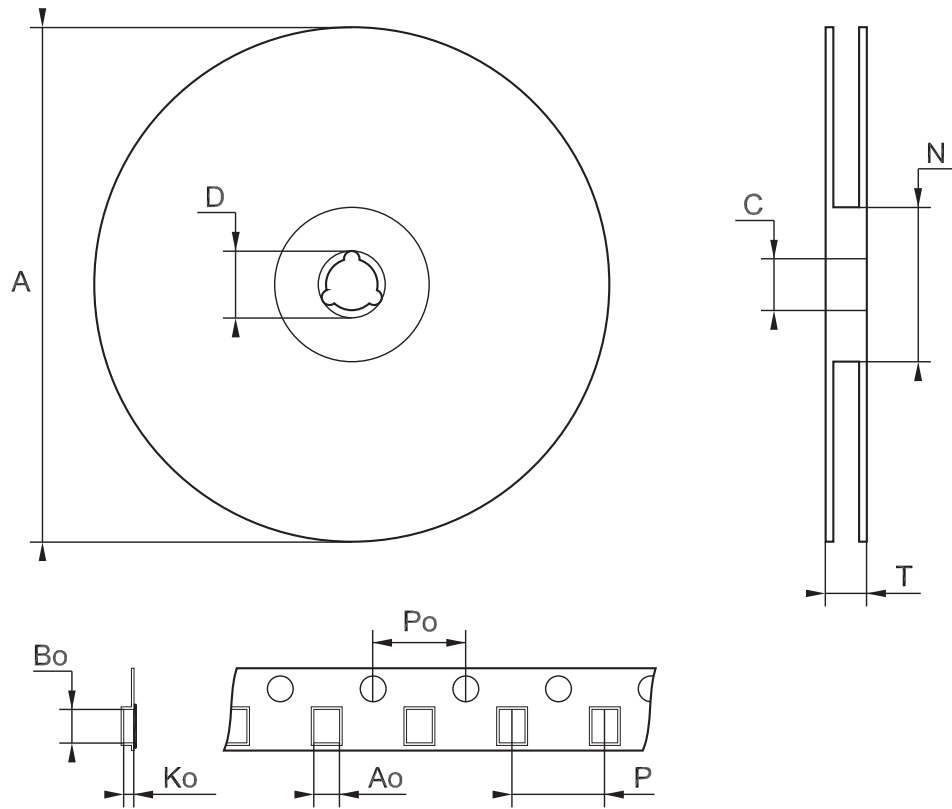

Table 9. HTSSOP16 exposed pad mechanical data

Dim.	mm.		
	Min.	Typ.	Max
A			1.20
A1			0.15
A2	0.80	1.00	1.05
b	0.19		0.30
c	0.09		0.20
D	4.90	5.00	5.10
D1	2.80	3.00	3.20
E	6.20	6.40	6.60
E1	4.30	4.40	4.50
E2	2.80	3.00	3.20
e		0.65	
L	0.45	0.60	0.75
L1		1.00	
k	0.00		8.00
aaa			0.10

10.2 HTSSOP16 packing information

Figure 12. HTSSOP16 tape and reel outline



Note: Drawing not in scale

Table 10. HTSSOP16 tape and reel mechanical data

Dim.	mm.		
	Min.	Typ.	Max.
A			330
C	12.8		13.2
D	20.2		
N	60		
T			22.4
Ao	6.7		6.9
Bo	5.3		5.5
Ko	1.6		1.8
Po	3.9		4.1
P	7.9		8.1

Revision history

Table 11. Document revision history

Date	Revision	Changes
29-Apr-2019	1	First release.

Contents

1	Pin description	2
2	Simplified internal block diagram	3
3	Absolute maximum ratings	4
3.1	Thermal characteristics	4
4	Electrical characteristics	5
5	Switching characteristics	6
6	Internal block diagram	7
7	Register description	8
8	Typical characteristics	9
9	Typical application	10
10	Package information	12
10.1	HTSSOP16 package information	13
10.2	HTSSOP16 packing information	14
	Revision history	15

List of tables

Table 1.	Pin description	2
Table 2.	Absolute maximum ratings	4
Table 3.	Thermal characteristics	4
Table 4.	Electrical characteristics	5
Table 5.	Switching characteristics	6
Table 6.	Switches output control	8
Table 7.	Switches versus output truth table	8
Table 8.	Table settings	9
Table 9.	HTSSOP16 exposed pad mechanical data	13
Table 10.	HTSSOP16 tape and reel mechanical data	14
Table 11.	Document revision history	15

List of figures

Figure 1.	Pinout for HTSSOP16	2
Figure 2.	LED8102S simplified block diagram	3
Figure 3.	t_{ON} - t_{OFF} time evaluation	6
Figure 4.	t_{PLH} - t_{PHL} time evaluation	6
Figure 5.	\overline{OE} Terminal	7
Figure 6.	SWx Terminals	7
Figure 7.	I_{SET} vs. drop-out voltage (V_{DROP} @ 25 °C)	9
Figure 8.	Typical application circuit	10
Figure 9.	Power dissipation rating vs ambient temperature ($R_{th} = 37.5$ °C/W; $T_j = 125$ °C)	11
Figure 10.	Junction temperature vs ambient temperature ($R_{th} = 37.5$ °C/W; $P_d = 1$ W)	11
Figure 11.	HTSSOP16 exposed pad package outline	13
Figure 12.	HTSSOP16 tape and reel outline	14

IMPORTANT NOTICE – PLEASE READ CAREFULLY

STMicroelectronics NV and its subsidiaries (“ST”) reserve the right to make changes, corrections, enhancements, modifications, and improvements to ST products and/or to this document at any time without notice. Purchasers should obtain the latest relevant information on ST products before placing orders. ST products are sold pursuant to ST’s terms and conditions of sale in place at the time of order acknowledgement.

Purchasers are solely responsible for the choice, selection, and use of ST products and ST assumes no liability for application assistance or the design of Purchasers’ products.

No license, express or implied, to any intellectual property right is granted by ST herein.

Resale of ST products with provisions different from the information set forth herein shall void any warranty granted by ST for such product.

ST and the ST logo are trademarks of ST. For additional information about ST trademarks, please refer to www.st.com/trademarks. All other product or service names are the property of their respective owners.

Information in this document supersedes and replaces information previously supplied in any prior versions of this document.

© 2019 STMicroelectronics – All rights reserved