

Programmable shunt voltage reference

Features

- Adjustable output voltage: 2.5 to 24 V
- Precision selection at 25° C: $\pm 2\%$, $\pm 1\%$ and $\pm 0.5\%$
- Sink current capability: 1 to 100 mA
- Industrial temperature range: -40 to +105° C
- Performances compatible with industry-standard TL431

Applications

- Computers
- Instrumentation
- Battery chargers
- Switch mode power supplies
- Battery-operated equipment

Description

The TS2431 is a programmable shunt voltage reference with guaranteed temperature stability over the entire temperature range of operation -40 to +105° C. The output voltage may be set to any value between 2.5 and 24 V with an external resistor bridge.

Available in a SOT23-3 surface mount package, the device can be implemented in applications where space-saving is of utmost importance.

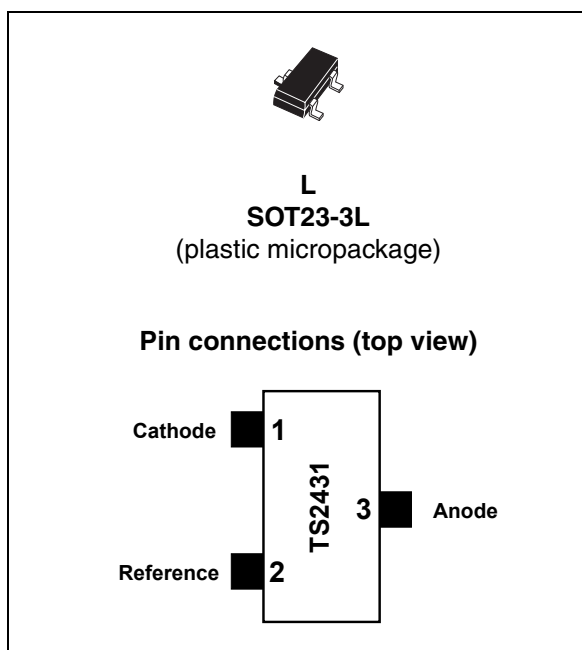

1 Absolute maximum ratings and operating conditions

Table 1. Absolute maximum ratings

Symbol	Parameter	Value	Unit
V _{ka}	Cathode to anode voltage	25	V
I _K	Reverse breakdown current	-100 to +150	mA
I _{REF}	Reference input current range	-0.05 to +10	mA
P _d	Power dissipation ⁽¹⁾ SOT23-3	360	mW
T _{std}	Storage temperature	-65 to +150	°C
ESD	Human body model (HBM) ⁽²⁾	2	kV
	Machine model (MM) ⁽³⁾	200	V
T _{LEAD}	Lead temperature (soldering, 10 seconds)	260	°C

1. P_d has been calculated with T_{amb} = 25°C, T_{junction} = 150°C, R_{thjc} = 110°C/W and R_{thja} = 340°C/W for the SOT23-3 package.
2. Human body model: a 100 pF capacitor is charged to the specified voltage, then discharged through a 1.5 kΩ resistor between two pins of the device. This is done for all couples of connected pin combinations while the other pins are floating.
3. Machine model: a 200 pF capacitor is charged to the specified voltage, then discharged directly between two pins of the device with no external series resistor (internal resistor < 5 Ω). This is done for all couples of connected pin combinations while the other pins are floating.

Table 2. Operating conditions

Symbol	Parameter	Value	Unit
V _{KA}	Cathode to anode voltage	V _{REF} to 24	V
I _K	Cathode operating current ⁽¹⁾	1 to 100	mA
T _{oper}	Operating free air temperature range	-40 to +105	°C

1. Maximum power dissipation must be strictly observed to avoid damaging the component.

2 Electrical characteristics

Table 3. Electrical characteristics (T_{amb} = 25° C unless otherwise specified)

Symbol	Parameter	Test Condition	Min.	Typ.	Max.	Unit
V _{REF}	Reference input voltage	V _K = V _{REF} I _K = 10 mA		2.5		V
		TS2431 (2%)	2.45		2.55	
		TS2431A (1%)	2.475		2.525	
		TS2431B (0.5%)	2.488		2.512	
ΔV _{REF}	Reference input voltage deviation over temperature V _K = V _{REF} I _K = 10 mA ⁽¹⁾ (2)	0° C < T < +70° C		10	20	mV
		-40° C < T < +85° C		17	30	
		-40° C < T < +105° C		20	35	
T _C	Temperature coefficient (note 2)	-40° C < T < +105° C		50	100	ppm/°C
I _{KMIN}	Minimum operating current	T = 25° C		0.3	0.8	mA
		-40° C < T < +105° C			1	
$\frac{ \Delta V_{ref} }{ \Delta V_K }$	Ratio of change in reference input voltage to change in cathode to anode voltage	I _K = 10 mA V _{ka} = 24 to 2.5 V		0.3	2	mV/V
I _{REF}	Reference input current I _K = 10 mA, R1 = 10 KΩ, R2 = +∞ ⁽³⁾	T = 25° C		0.5	2.5	μA
		-40° C < T < +105° C			3	
ΔI _{REF}	Reference input current deviation I _K = 10 mA, R1 = 10 KΩ, R2 = +∞ ⁽³⁾	-40° C < T < +105° C		0.4	1.2	μA
I _{OFF}	Off-state cathode current	V _K = 24 V, V _{REF} = GND		10	500	nA
Z _{KAL}	Reverse dynamic impedance	V _K = V _{REF} ΔI _K = 1 to 50 mA, f < 10 kHz		0.5	0.75	W
E _N	Wide band noise	I _K = 10 mA 10 Hz < f < 10 kHz		300		nV/√Hz

- Limits are 100% production tested at 25° C. Limits over temperature are guaranteed through correlation and by design.
- |ΔV_{REF}| is defined as the difference between the maximum and minimum values of V_{REF} obtained over the full temperature range.
- Refer to [Figure 4: Test circuit for V_{ka} = V_{ref} on page 4.](#)

Figure 1. Reference voltage vs temperature

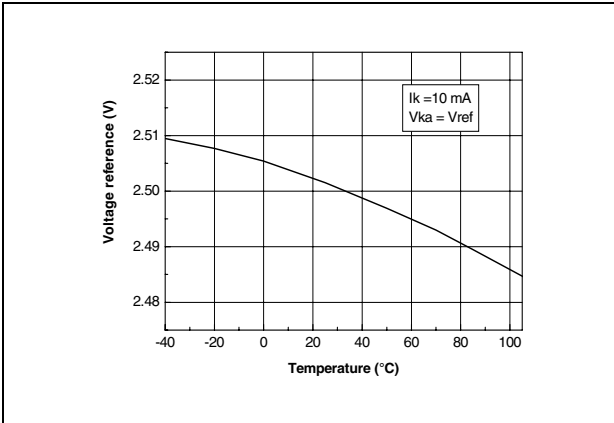

Figure 2. Cathode voltage vs cathode current

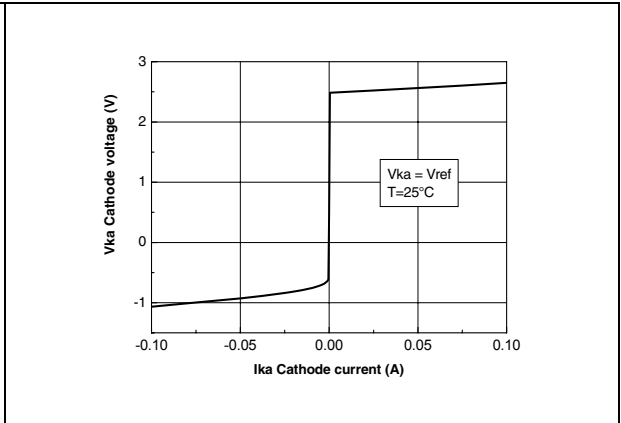

Figure 3. Reference input current vs temperature

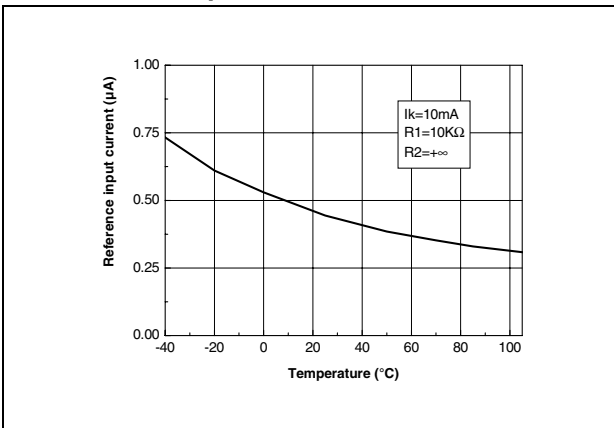

Figure 4. Test circuit for Vka = Vref

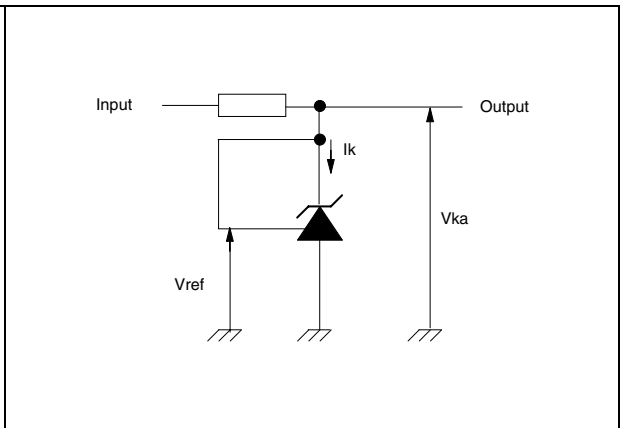

Figure 5. Cathode voltage vs cathode current

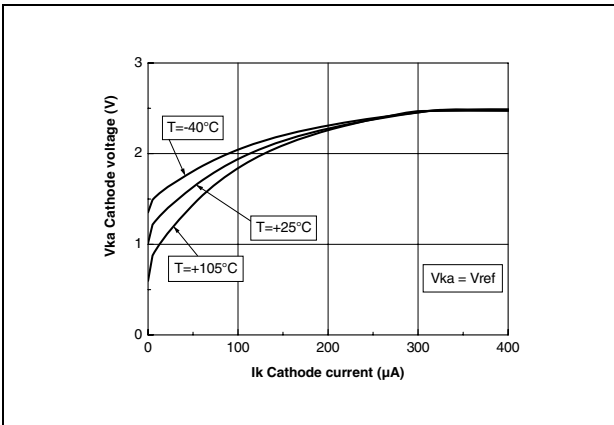

Figure 6. Dynamic impedance vs frequency

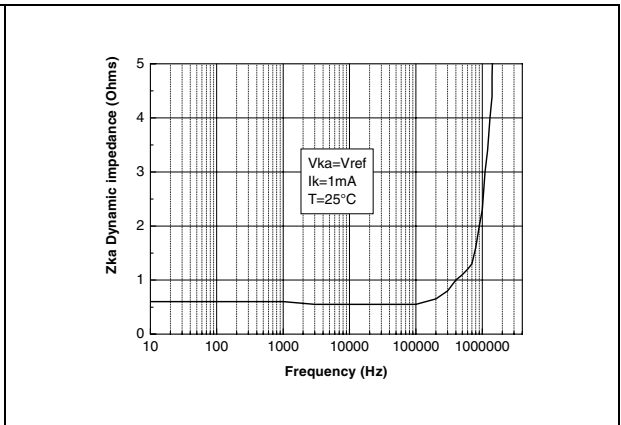

Figure 7. Off-state current vs temperature

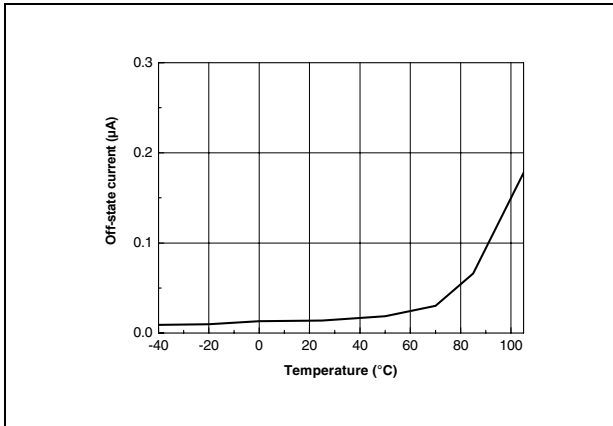

Figure 8. Ratio of change in reference input voltage to change in Vka voltage vs temperature

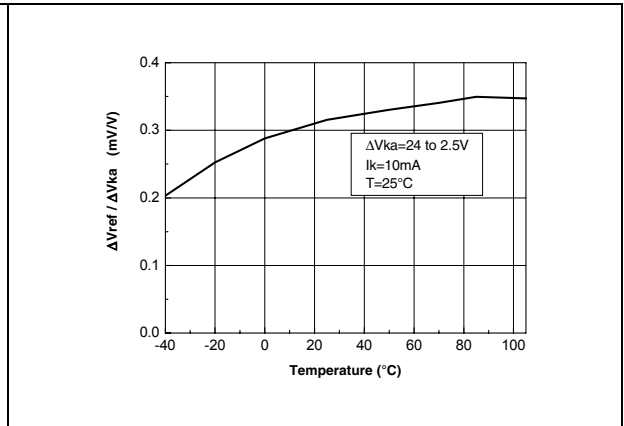

Figure 9. Phase and gain vs frequency

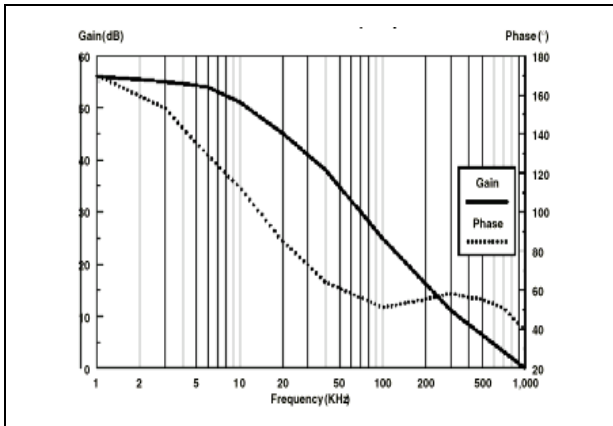

Figure 10. Test circuit for off-state current measurement

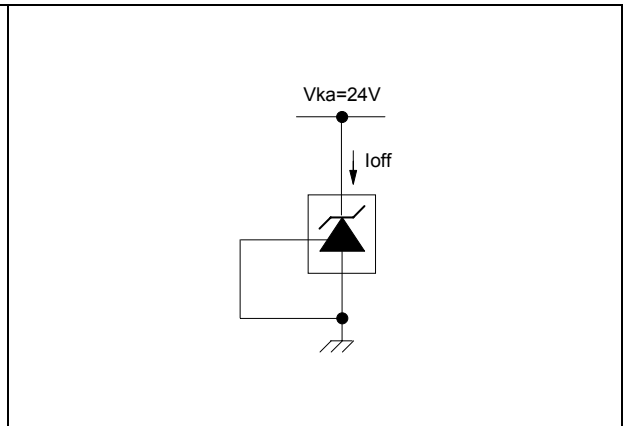

Figure 11. Test circuit for Vka > Vref

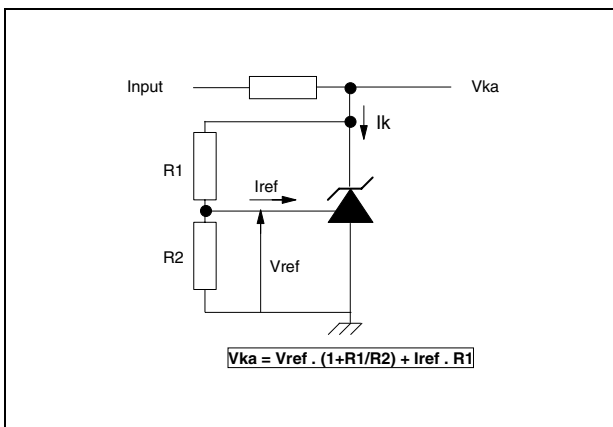

Figure 12. Test circuit for phase and gain measurement

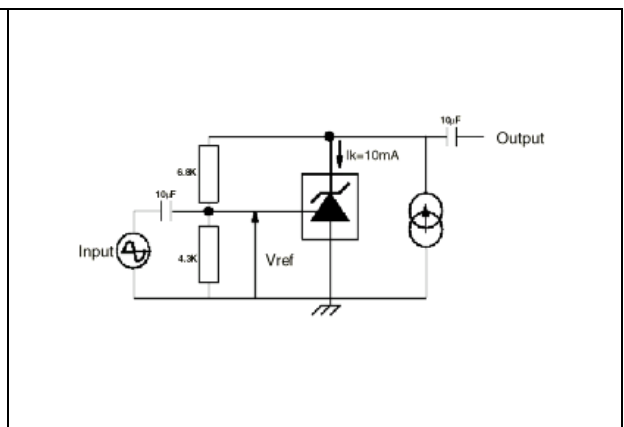

Figure 13. Pulse response at $I_k = 1\text{ mA}$

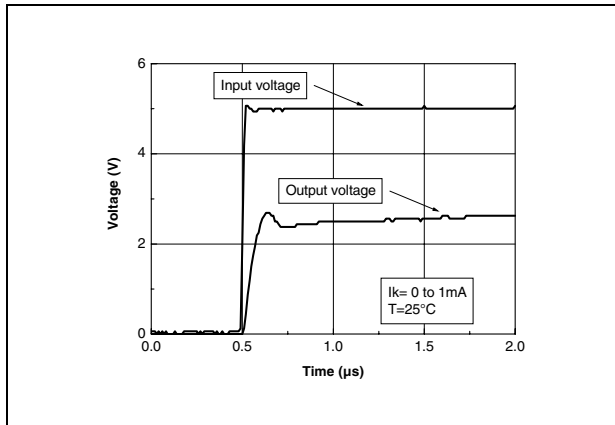

Figure 14. Pulse response at $I_k = 1\text{ mA}$

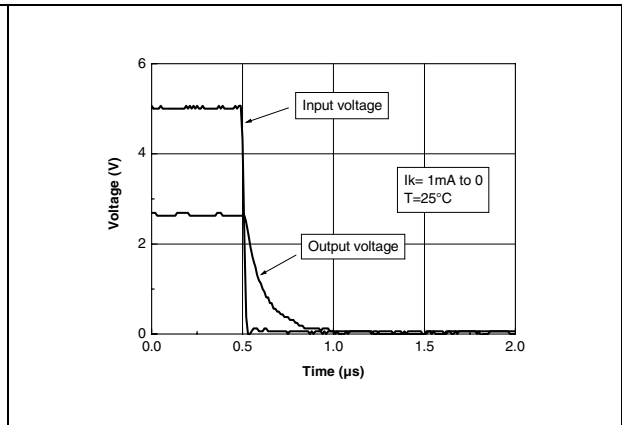

Figure 15. Stability boundary conditions

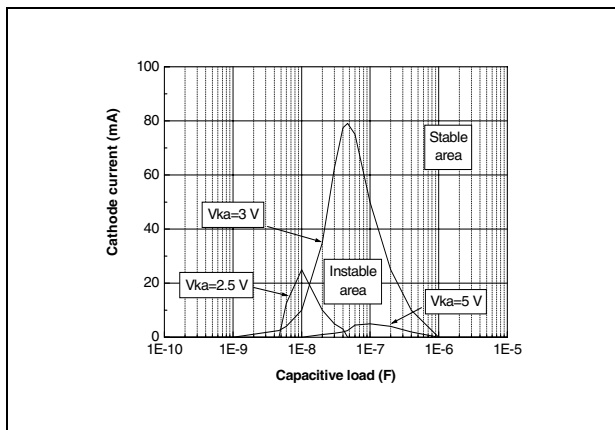

Figure 16. Test circuit for pulse response at $I_k = 1\text{ mA}$

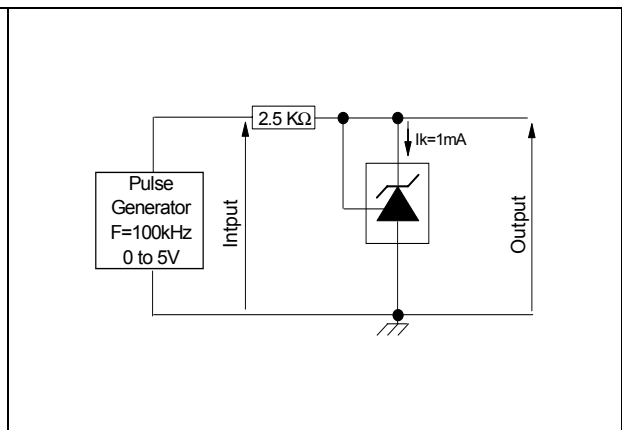

Figure 17. Equivalent input noise vs frequency

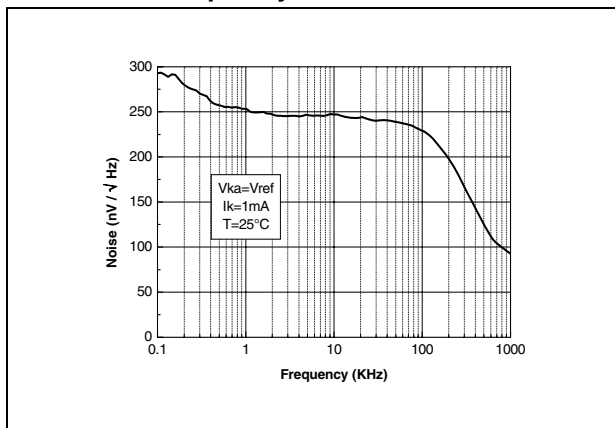
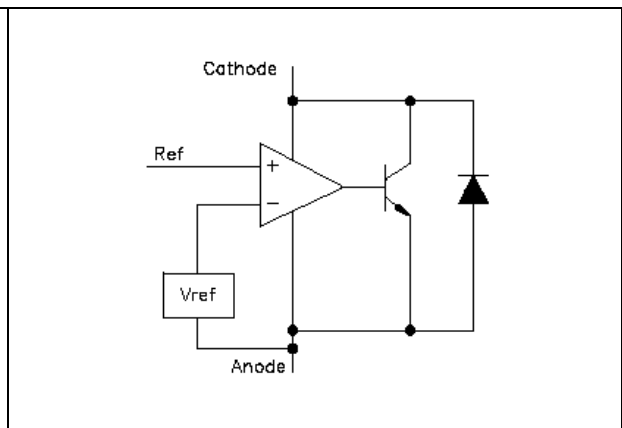

Figure 18. Block Diagram



3 Package information

In order to meet environmental requirements, ST offers these devices in different grades of ECOPACK[®] packages, depending on their level of environmental compliance. ECOPACK[®] specifications, grade definitions and product status are available at: www.st.com. ECOPACK[®] is an ST trademark.

3.1 SOT23-3 package information

Figure 19. SOT23-3 package mechanical drawing

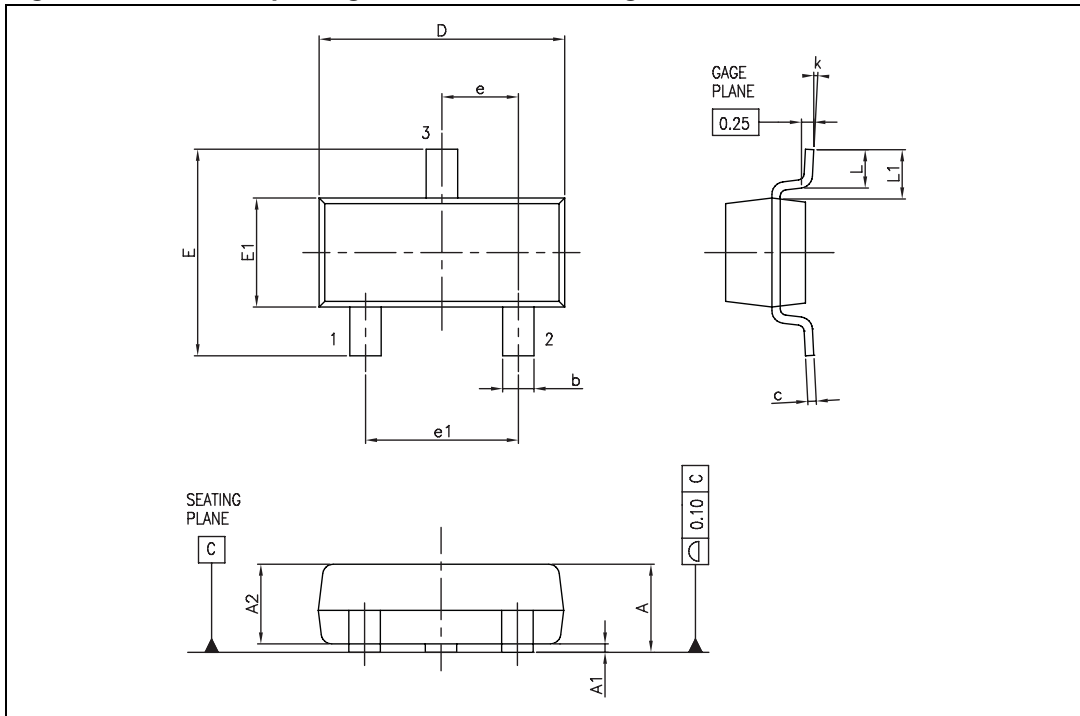

Table 4. SOT23-3 package mechanical data

Dimensions						
Ref.	Millimeters			Inches		
	Min.	Typ.	Max.	Min.	Typ.	Max.
A	0.89		1.12	0.035		0.044
A1	0.01		0.10	0.0004		0.004
A2	0.88	0.95	1.02	0.035	0.037	0.040
b	0.30		0.50	0.012		0.020
c	0.08		0.20	0.003		0.008
D	2.80	2.90	3.04	0.110	0.114	0.120
E	2.10		2.64	0.083		0.104
E1	1.20	1.30	1.40	0.047	0.051	0.055
e		0.95			0.037	
e1		1.90			0.075	
L	0.40	0.50	0.60	0.016	0.020	0.024
L1		0.54			0.021	
k	0d		8d			

4 Ordering information

Table 5. Order codes

Order code	Temperature range	Package	Packing	Precision	Marking
TS2431ILT	-40 to +105°C	SOT23-3	Tape & reel	2%	L285
TS2431AILT				1%	L286
TS2431BILT				0.5%	L287
TS2431IYLT ⁽¹⁾		SOT23-3 (automotive grade)		2%	L289
TS2431AIYLT ⁽¹⁾				1%	L290
TS2431BIYLT ⁽¹⁾				0.5%	L291

1. Qualification and characterization according to AEC Q100 and Q003 or equivalent, advanced screening according to AEC Q001 & Q 002 or equivalent are on-going.

5 Revision history

Table 6. Document revision history

Date	Revision	Changes
01-Feb-2002	1	Initial release.
10-Sep-2009	2	Updated document format. Modified footnote 1 under Table 1: Absolute maximum ratings on page 2 . Added HBM and MM notes under Table 1 . Added automotive grade order codes in Table 5: Order codes .

Please Read Carefully:

Information in this document is provided solely in connection with ST products. STMicroelectronics NV and its subsidiaries ("ST") reserve the right to make changes, corrections, modifications or improvements, to this document, and the products and services described herein at any time, without notice.

All ST products are sold pursuant to ST's terms and conditions of sale.

Purchasers are solely responsible for the choice, selection and use of the ST products and services described herein, and ST assumes no liability whatsoever relating to the choice, selection or use of the ST products and services described herein.

No license, express or implied, by estoppel or otherwise, to any intellectual property rights is granted under this document. If any part of this document refers to any third party products or services it shall not be deemed a license grant by ST for the use of such third party products or services, or any intellectual property contained therein or considered as a warranty covering the use in any manner whatsoever of such third party products or services or any intellectual property contained therein.

UNLESS OTHERWISE SET FORTH IN ST'S TERMS AND CONDITIONS OF SALE ST DISCLAIMS ANY EXPRESS OR IMPLIED WARRANTY WITH RESPECT TO THE USE AND/OR SALE OF ST PRODUCTS INCLUDING WITHOUT LIMITATION IMPLIED WARRANTIES OF MERCHANTABILITY, FITNESS FOR A PARTICULAR PURPOSE (AND THEIR EQUIVALENTS UNDER THE LAWS OF ANY JURISDICTION), OR INFRINGEMENT OF ANY PATENT, COPYRIGHT OR OTHER INTELLECTUAL PROPERTY RIGHT.

UNLESS EXPRESSLY APPROVED IN WRITING BY AN AUTHORIZED ST REPRESENTATIVE, ST PRODUCTS ARE NOT RECOMMENDED, AUTHORIZED OR WARRANTED FOR USE IN MILITARY, AIR CRAFT, SPACE, LIFE SAVING, OR LIFE SUSTAINING APPLICATIONS, NOR IN PRODUCTS OR SYSTEMS WHERE FAILURE OR MALFUNCTION MAY RESULT IN PERSONAL INJURY, DEATH, OR SEVERE PROPERTY OR ENVIRONMENTAL DAMAGE. ST PRODUCTS WHICH ARE NOT SPECIFIED AS "AUTOMOTIVE GRADE" MAY ONLY BE USED IN AUTOMOTIVE APPLICATIONS AT USER'S OWN RISK.

Resale of ST products with provisions different from the statements and/or technical features set forth in this document shall immediately void any warranty granted by ST for the ST product or service described herein and shall not create or extend in any manner whatsoever, any liability of ST.

ST and the ST logo are trademarks or registered trademarks of ST in various countries.

Information in this document supersedes and replaces all information previously supplied.

The ST logo is a registered trademark of STMicroelectronics. All other names are the property of their respective owners.

© 2009 STMicroelectronics - All rights reserved

STMicroelectronics group of companies

Australia - Belgium - Brazil - Canada - China - Czech Republic - Finland - France - Germany - Hong Kong - India - Israel - Italy - Japan - Malaysia - Malta - Morocco - Philippines - Singapore - Spain - Sweden - Switzerland - United Kingdom - United States of America

www.st.com

