

LOC	DIST	P	F	ZONE	LTR	DESCRIPTION	DATE	APPD
CM	53					REV PER EC 0730-0142-94	8-15-94	RV RS

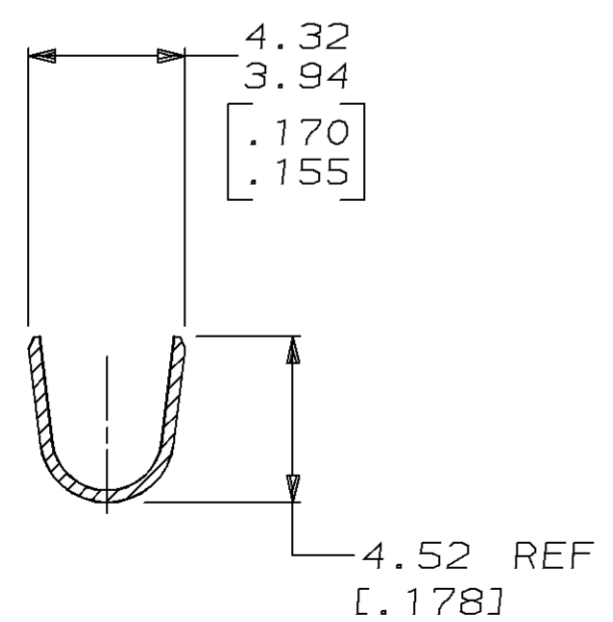
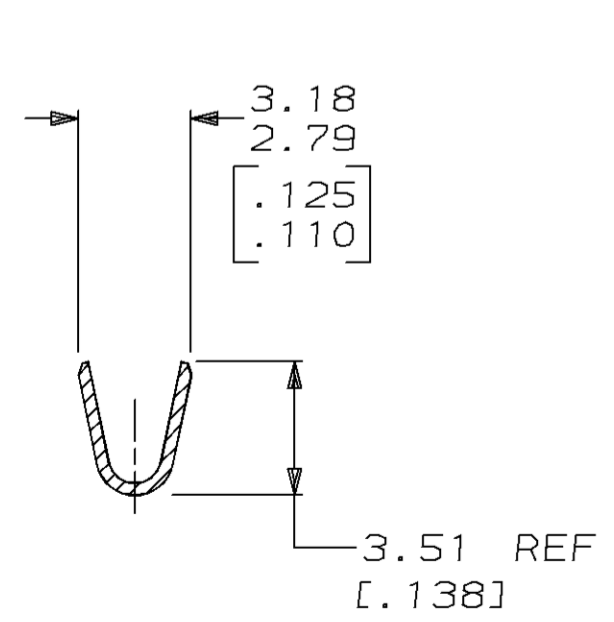
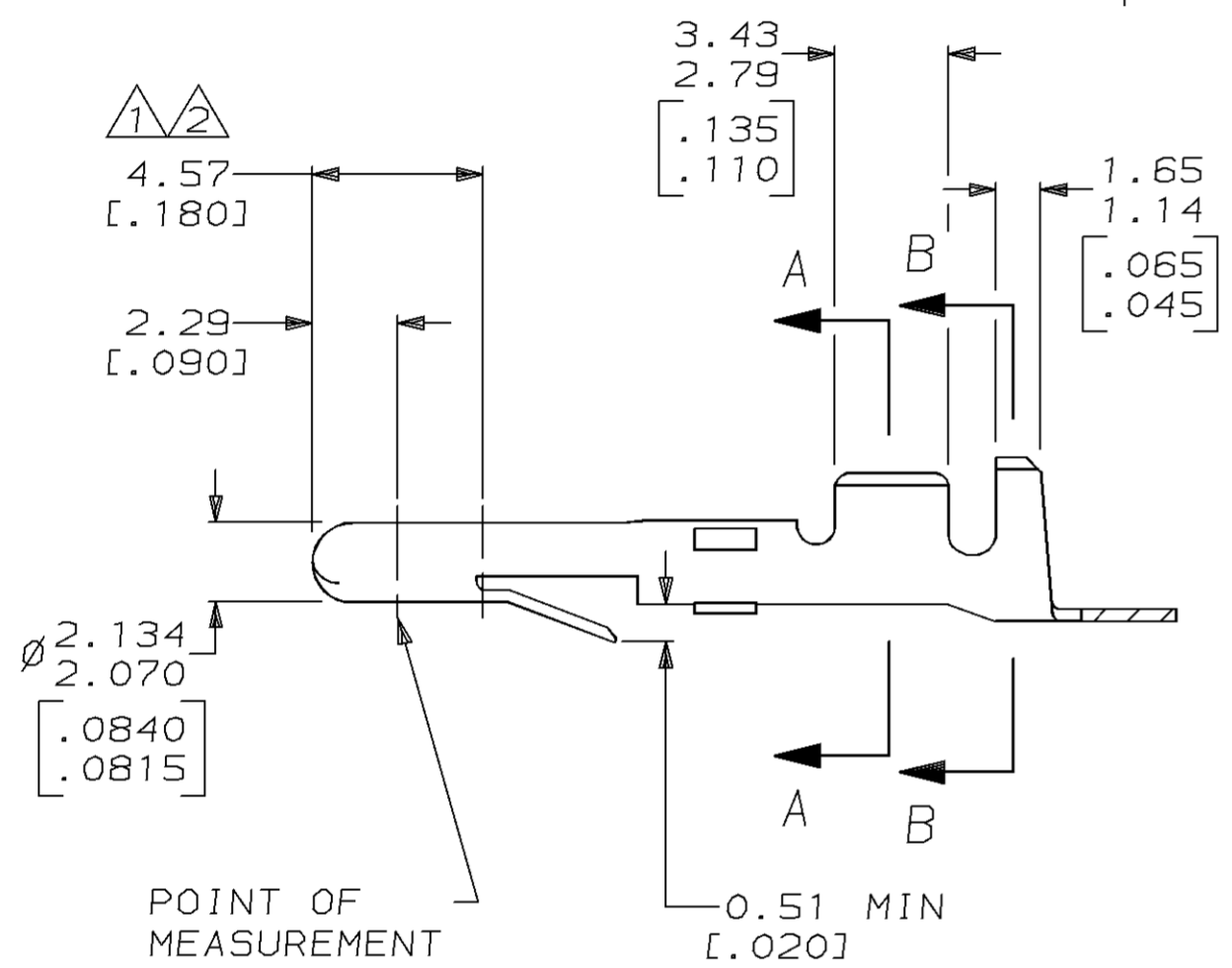
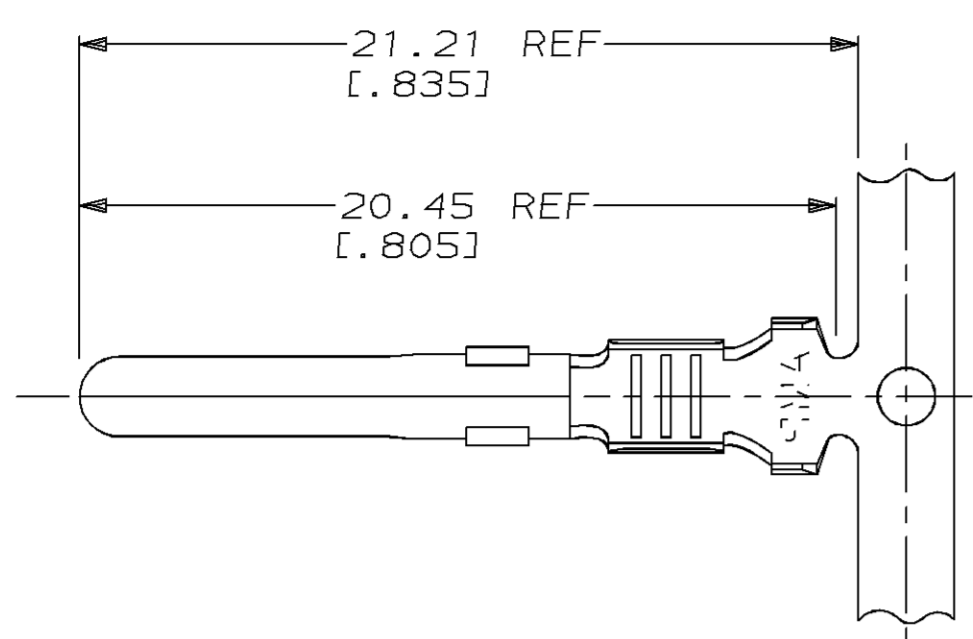

- ① PLATE OVERALL WITH 0.00127 [.000050] MIN NICKEL, THEN TIP PLATE WITH 0.00076 [.000030] MIN GOLD IN THE MATING AREA.
- ② PLATE OVERALL WITH 0.00127 [.000050] MIN NICKEL, THEN PLATE IN THE MATING AREA AND STRIPE THE INSIDE OF THE WIRE BARREL WITH 0.00076 [.000030] MIN GOLD.
- 3. WIRE RANGE: 0.5 - 2 mm² [20 - 14 AWG].
- 4. INSULATION RANGE: 3.30 [.130] MAX DIA.
- 5. APPLICATION TYPE: MINI.
- 6. DIMENSIONS IN BRACKETS ARE IN INCHES.

FINISH	MATERIAL	PART NO
①	0.33 [.012] BRASS	61118-7
②	0.33 [.012] PH BRZ	61118-6
③	0.33 [.012] BRASS	61118-5
PRE-TIN	0.33 [.012] PH BRZ	61118-4
-	0.33 [.012] BRASS	61118-2
PRE-TIN	0.33 [.012] BRASS	61118-1

DO NOT SCALE PRINT. UNLESS SPECIFIED DIMENSIONS IN mm [INCHES] TOLERANCES ON : 2 PLC DEC ± - 3 PLC DEC ± 0.13 [.005] ANGLES ± -	DR 11-20-92 T. BECK	AMP Incorporated Harrisburg, PA 17105-3608		
	CHK 11-20-92 R. SWING			NAME
SEE TABLE	APPD 12-9-92 D. SELF	PIN, MATE-N-LOK™		
SEE TABLE	APPD 12-9-92 D. SELF			
FINISH	APPLICATION SPEC	SIZE	CAGE CODE	DRAWING NO
SEE TABLE	-	③	00779	③-61118
	WEIGHT -	SCALE	5:1	SHEET 1 OF 1

METRIC

THIS DRAWING IS A CONTROLLED DOCUMENT FOR AMP INCORPORATED. IT IS SUBJECT TO CHANGE AND THE CONTROLLING ENGINEERING ORGANIZATION SHOULD BE CONTACTED FOR THE LATEST REVISION.