



**NOTE**

All numerical values are in metric units [with U.S. customary units in brackets]. Dimensions are in millimeters. Unless otherwise specified, dimensions have a tolerance of  $\pm 0.13$  mm and angles have a tolerance of  $\pm 2^\circ$ . Figures and illustrations are for identification only and are not drawn to scale.

**1. INTRODUCTION**

This specification covers the requirements for application of VAL-U-LOK Series Headers, Connectors and Terminal Position Assurance (TPA) accessories. This product line consist of contacts which are installed in 2- through 24-position plug and receptacle connector housings. These housings may mate with each other for wire-to-wire applications. The receptacle housing also mates with printed circuit (pc) board right-angle or vertical header assemblies. The plug housings may be free hanging or panel mounted. The header assemblies come with pre-loaded contacts, and may be installed on the pc board manually, or automatically using robotic equipment. Standard contacts will accept 26-16 AWG wire and TPA-compatible contacts will accept 26-18 AWG wire.

When corresponding with TE Connectivity Personnel, use the terminology provided in this specification to facilitate your inquiries for information. Basic terms and features of this product are provided in Figure 1.

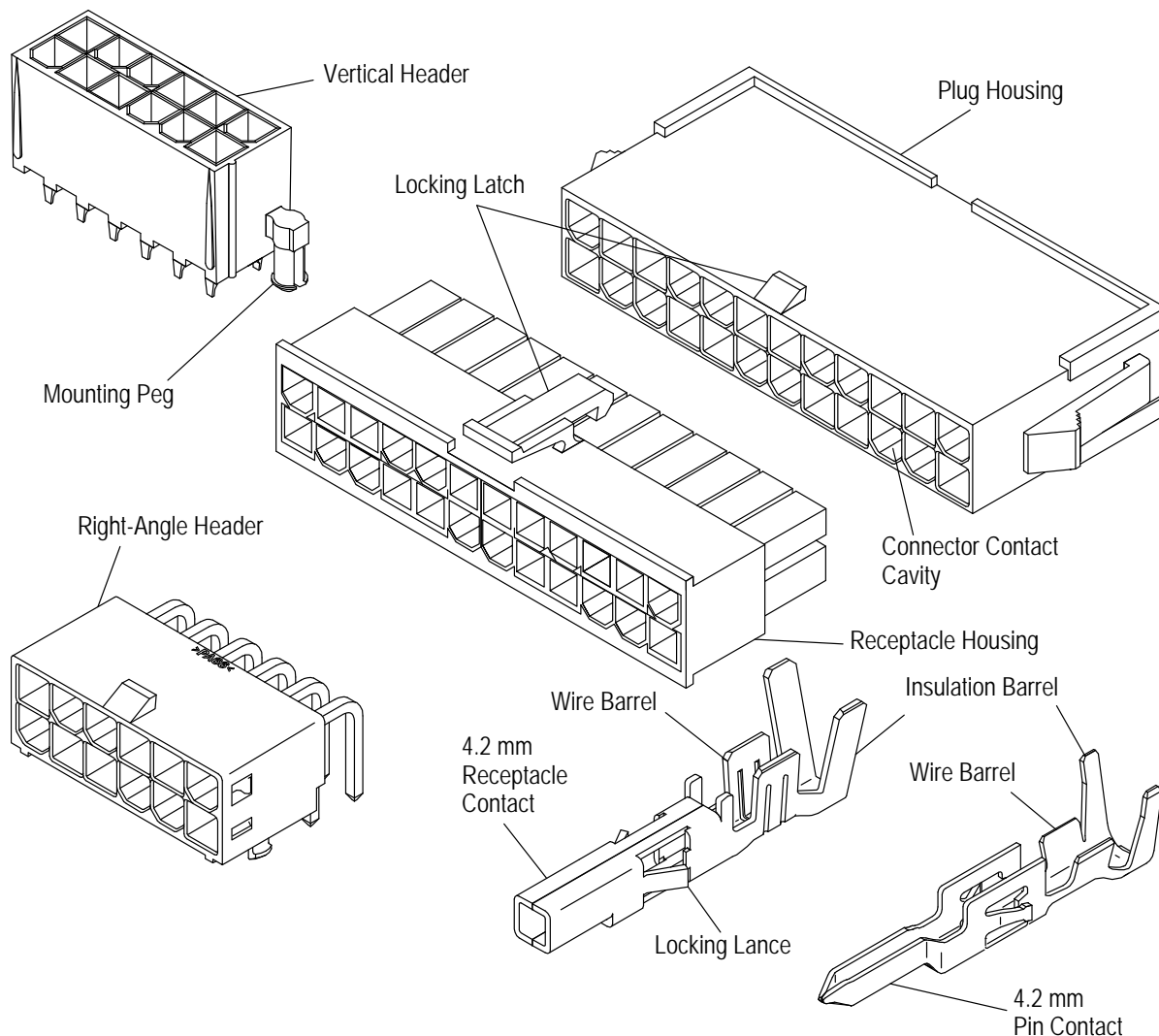

Figure 1 (Cont'd)

**NOTE: TPA Accessories (Optional)**

*TPA Accessories Must Only be Used with TPA Compatible Contacts and Connector Housings*

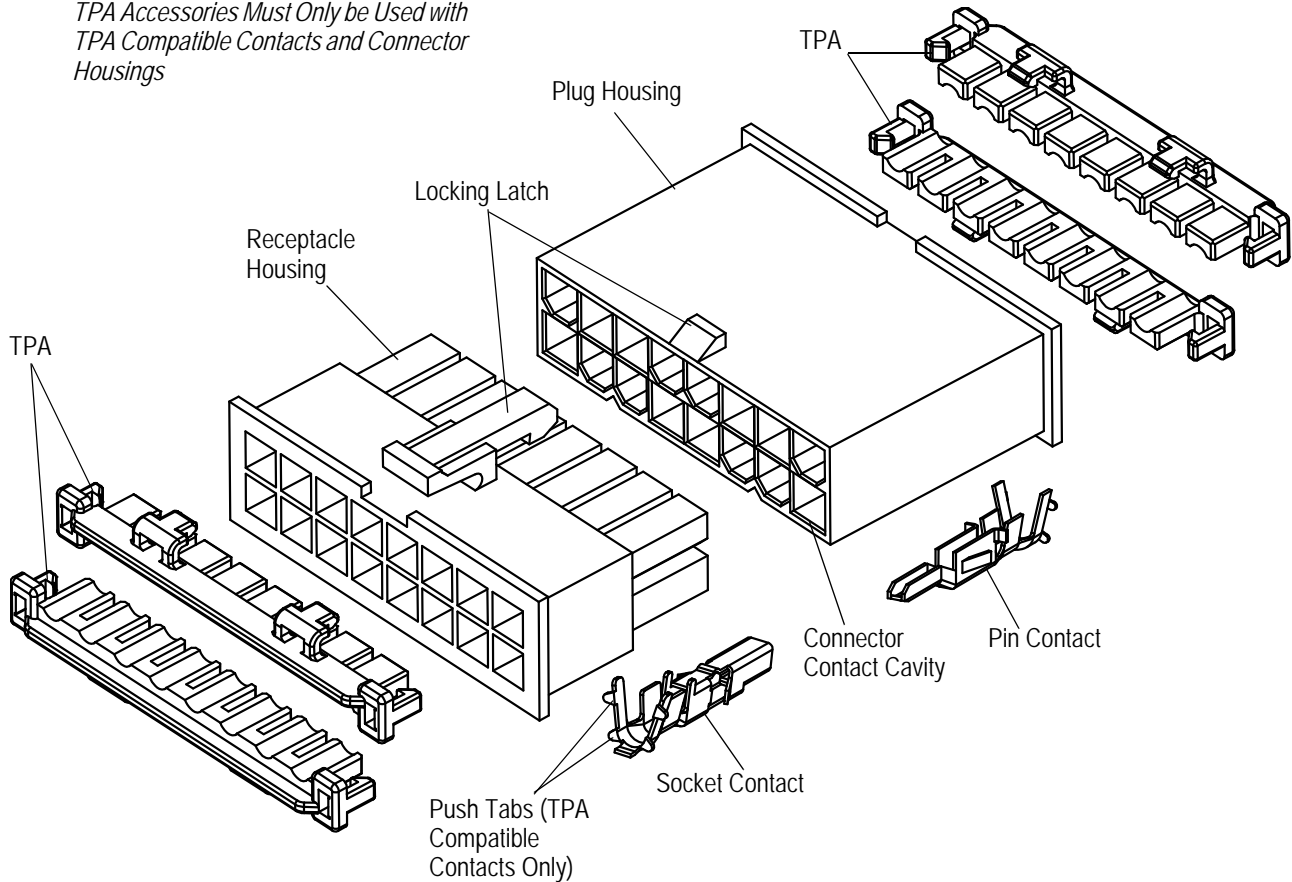

Figure 1 (End)

## 2. REFERENCE MATERIAL

### 2.1. Revision Summary

- Corrected contact artwork in Figure 1 (page 2)

### 2.2. Customer Assistance

Reference Product Base Part Number 794954 and Product Code K924 are representative of VAL-U-LOK Series Headers and Connectors. Use of these numbers will identify the product line and help you to obtain product and tooling information. Such information can be obtained through a local TE Representative, by visiting our website at [www.te.com](http://www.te.com), or by calling PRODUCT INFORMATION or the TOOLING ASSISTANCE CENTER at the numbers at the bottom of page 1.

### 2.3. Drawings

Customer drawings for specific products are available from the service network. The information contained in customer drawings takes priority if there is a conflict with this specification or with any technical documentation supplied by TE.

### 2.4. Manuals

Manual 402-40 is available upon request and can be used as a guide in soldering. This manual provides information on various flux types and characteristics along with the commercial designation and flux removal procedures. A checklist is included in the manual as a guide for information on soldering problems.

### 2.5. Specifications

Product Specification 108-2112 provides expected product performance requirements and test information.

## 2.6. Instructional Material

The following list includes available instruction sheets (408-series) that provide assembly procedures for product, operation, maintenance and repair of tooling, as well as setup and operation procedures of applicators; and customer manuals (409-series) that provides setup, operation, and maintenance of machines.

Document Number    Document Title

408-3295	Preparing Reel of Contacts for Applicator Tooling
408-8040	Heavy Duty Miniature Quick-Change Applicators (Side-Feed Type)
408-8053	Conversion Guide for Miniature Quick Change Applicators
408-8917	PRO-CRIMPER* III Hand Tool Assembly 91387-1 with Die Assembly 91387-2
408-8918	PRO-CRIMPER III Hand Tool Assembly 91388-1 with Die Assembly 91388-2
408-9816	Handling of Reeled Products
408-32113	VAL-U-LOK Connector System with Terminal Position Assurance
408-32114	Extraction Tool 1586343-1 for VAL-U-LOK Contacts
409-5128	Basic AMP-O-LECTRIC* Model "K" Terminating Machine
409-5842	AMP-O-LECTRIC Model "G" Terminating Machine 354500-[ ]
409-5878	AMPOMATOR* CLS IV+ Lead-Making Machine 356500-[ ]

## 3. REQUIREMENTS

### 3.1. Storage

#### A. Ultraviolet Light

Prolonged exposure to ultraviolet light may deteriorate the chemical composition used in the header assemblies or housings.

#### B. Shelf Life

The header assemblies and housings should remain in the shipping containers until ready for use to prevent damage. These products should be used on a first in, first out basis to avoid storage contamination.

#### C. Reeled Contacts

When using reeled contacts, store coil wound reels horizontally and traverse wound reels vertically.

#### D. Chemical Exposure

Do not store housings or header assemblies near any chemicals listed below, as they may cause stress corrosion cracking in the components.

Alkalies	Ammonia	Citrates	Phosphates	Citrates	Sulfur Compounds
Amines	Carbonates	Nitrites	Sulfur	Nitrites	Tartrates



**NOTE**

*Where the above environmental conditions exist, phosphor-bronze contacts are recommended instead of brass if available.*

### 3.2. Special Characteristics

VAL-U-LOK Series Headers and Connectors are available as a wire-to-board or wire-to-wire connector system designed for power applications. The housings and header assemblies are designed on 4.2 x 4.2 mm centerlines. The housings are polarized to prevent mis-mating. The vertical headers are available with or without mounting pegs and with drain holes.

### 3.3. Wire Selection and Preparation

Standard contacts will accept a wire size ranges of 26-22, 22-18, and 16 AWG. TPA-compatible contacts will accept wire size ranges of 26-22 and 22-18 AWG. All contacts are to be terminated to stranded wire. Figure 2 lists the insulation diameter range, strip length, and crimp height as determined by the wire size.



**CAUTION**

*When stripping the wire, care must be taken to avoid scraping, nicking, or cutting the conductor. Care must also be used when handling the wire during stripping and crimping to prevent cracking or breaking of the conductor and insulation.*



**NOTE**

Each crimp dimension represents the functional range of a wire/contact combination. There are tool designs available to meet various application requirements. The developed crimp configuration is unique for each tool design and is acceptable provided the crimp height is within the functional range. For crimp dimensions of a specific tool, refer to instruction sheet packaged with manual tools and applicator log packaged with power tools.

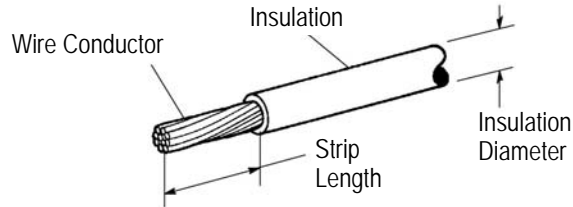

NOTE: Not to scale.

WIRE SIZE mm <sup>2</sup> [AWG]	INSUL DIAMETER RANGE	WIRE STRIP LENGTH	WIRE BARREL CRIMP HEIGHT
0.12 [26]	1.20-1.75	3.0-3.5	0.71-0.81
0.2 [24]	1.20-1.75	3.0-3.5	0.79-0.89
0.30 [22]	1.20-1.75	3.0-3.5	0.84-0.94
0.35 [22]	1.50-3.30	3.0-3.5	0.84-0.94 (0.86-0.96 for Hand Tool 91388-1)
0.5 [20]	1.50-3.30	3.0-3.5	0.94-1.04
0.87 [18]	1.50-3.30	3.0-3.5	1.04-1.14 (0.94-1.04 for Hand Tool 91388-1)
1.2 [16]	1.80-3.30	3.0-3.5	1.24-1.35
0.35 [22] + 0.35 [22]	1.50-3.30	3.5-4.0	1.04-1.14
0.35 [22] + 0.5 [20]	1.50-3.30	3.5-4.0	1.17-1.27

Figure 2

### 3.4. Crimped Contact Requirements

The contact shall be located in desired tooling and crimped according to the instructions packaged with that tooling, if available. See Section 5, TOOLING, of this document for details on tooling options and instructional materials.



**CAUTION**

Wire insulation shall NOT be cut or broken during the crimping operation, nor shall the insulation be crimped into the contact wire barrel. Reasonable care should be taken by tooling operators to provide undamaged wire terminations.

#### A. Contact Crimp Features

Figure 3 shows a typical contact as it should appear after crimping.

*1. Crimp Location*

For optimum crimp effectiveness, the crimp must be within the area shown and must meet the crimp requirements provided in Figure 3.

*2. Crimp Height*

The crimp applied to the wire barrel portion of the contact is the most compressed area and is most critical in ensuring optimum electrical and mechanical performance of the terminated contact. The contact wire barrel crimp height must be within the dimension provided in Figure 2.

*3. Effective Crimp Length*

Effective crimp length shall be defined as that portion of the wire barrel, excluding bellmouth(s), fully formed by the crimping tool. See Figure 3.

*4. Conductor Extension*

The conductor may extend beyond the wire barrel to the maximum shown in Figure 3.

**NOTE:** TPA compatible receptacle contact shown, but other pin and socket contact dimensions are the same.

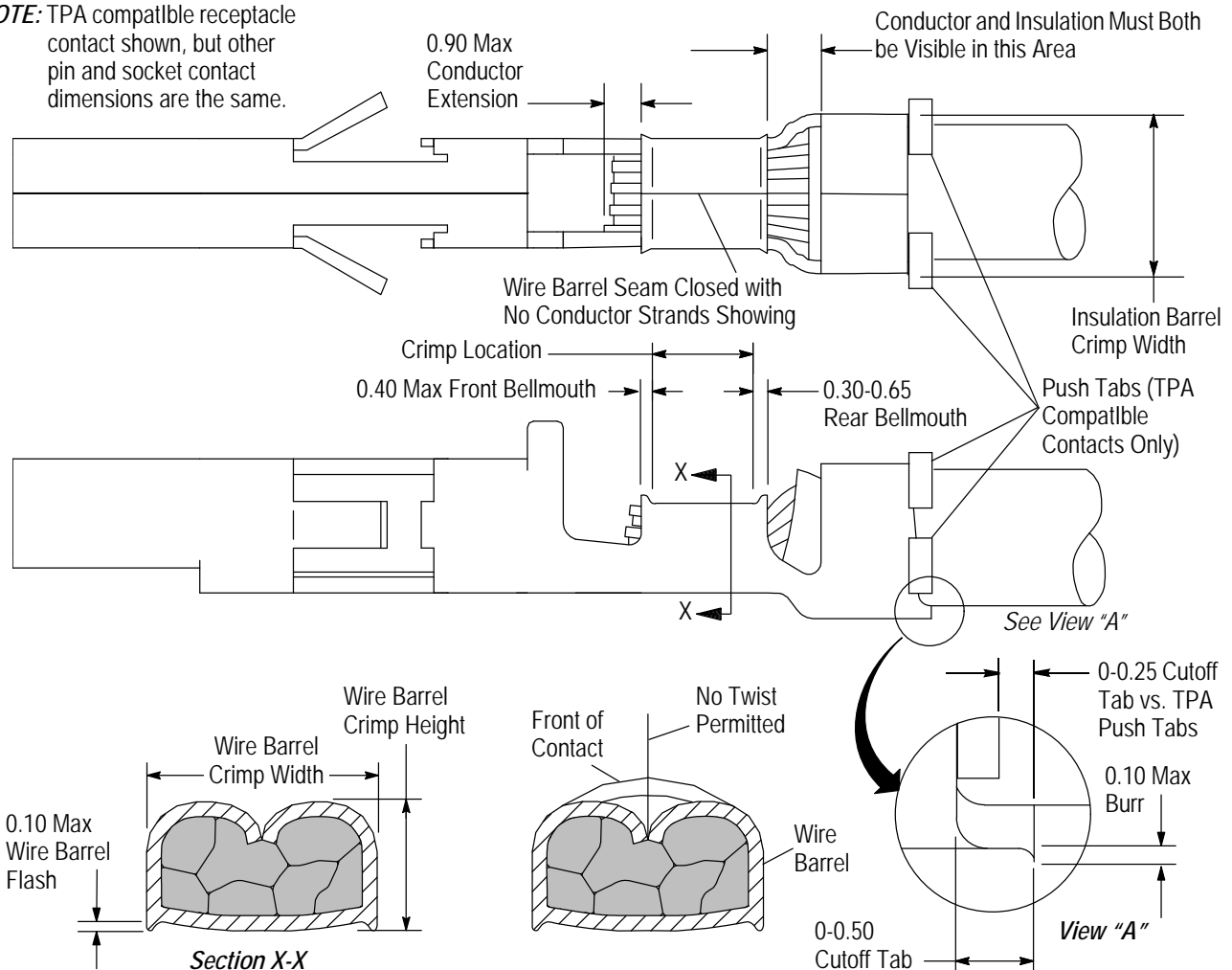

Figure 3



**CAUTION**

TPA-compatible contacts are equipped with four small push tabs on the insulation crimp barrel to facilitate function of the TPA accessory. Damage or distortion of these push tabs during the termination process is not permissible.

**5. Wire Barrel Seam**

The wire barrel seam must be closed with no evidence of loose wire strands visible in the seam.

**6. Conductor/Insulation**

The conductor and insulation must both be visible in the area between the insulation barrel and the wire barrel.

**7. Bellmouth**

The front and rear bellmouths are caused by the extrusion of metal during crimping and must be within the range specified in Figure 3.

**8. Cutoff Tab and Burr**

The cutoff tab and burr resulting from the contact being cut from the carrier strip must be within limits to allow the contact and optional TPA to be fully inserted and seated in the housing. See Figure 3.

**9. Flash**

The wire barrel flash at the bottom of the wire barrel results from applied crimp pressure and must be within the dimension provided in Section X-X of Figure 3.

### 10. Twist and Roll

There shall be no twist, roll, deformation, or other damage to the mating portion of the crimped contact that will prevent proper mating. See Figure 3.

### B. Straightness

The force applied during crimping may cause some bending between the crimped wire barrel and the mating portion of the contact. Such deformation is acceptable within the following limits.

#### 1. Up and Down

The crimped contact, including cutoff tab and burr, shall not be bent above or below the datum line more than the amount shown in Figure 4.

#### 2. Side to Side

The side-to-side bending of the contact may not exceed the limits provided in Figure 4.



#### NOTE

Periodic inspections must be made to ensure crimped contact formation is consistent as referenced.

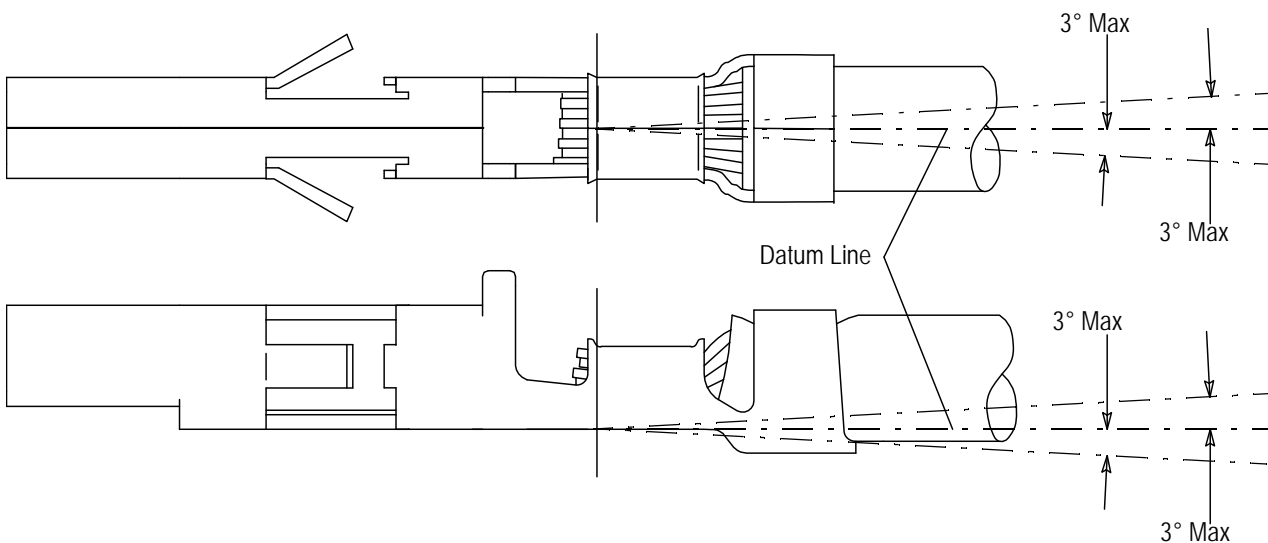

Figure 4

### 3.5. Assembly

#### A. Crimped Contact Insertion into Housing

The crimped contacts must be inserted in the back of the housing and snapped into place. Install the contact so the wire barrel is facing the housing latch. When fully inserted, the locking lances will engage the housing and prevent backing out during mating of the connector. After inserting contact into housing, pull back lightly on the wire to ensure contact is fully seated. See Figure 5.

#### B. TPA Installation

For applications requiring the use of a TPA device, TPA-compatible contacts and housings must be employed. The TPA device will not work with standard contacts and housings. Once all the TPA-compatible contacts have been inserted, the TPA device may now be installed. The TPA must be oriented with the teeth facing the wire entry openings of the housing, the radius surfaces of the teeth lying on top of the wires and the latches aligned with the raised ledges around the perimeter of the housing. Then the TPA must be inserted so that the teeth enter the housing contact cavities over the wires and the locking latches engage the housing ledges. There should be an audible and tactile “click” as each latch is individually engaged.

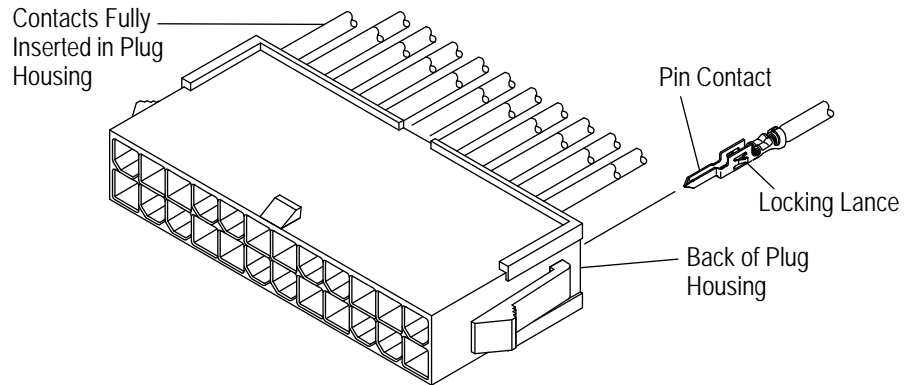

Figure 5

### 3.6. Strain Relief and Wire Dress

If required, wires can be bundled together and supported with cable ties. Wires must not be stretched or confined in any way that would restrict the floating action of the contacts. Therefore, the wires must remain perpendicular to the connector and avoid an excessively sharp bend radius. The minimum distance for the cable tie, measured from the wire end of the connector to the cable tie is shown in Figure 6.

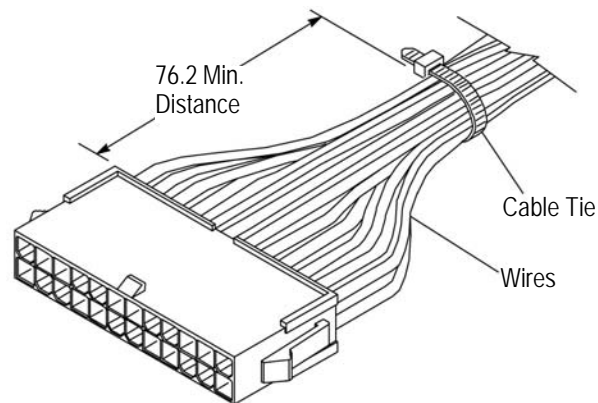

Figure 6

### 3.7. Connector Assembly

The plug and receptacle connectors will mate according to the polarization designed in the housings. Once the connectors have been mated, the latch will secure them from becoming unmated. See Figure 7.

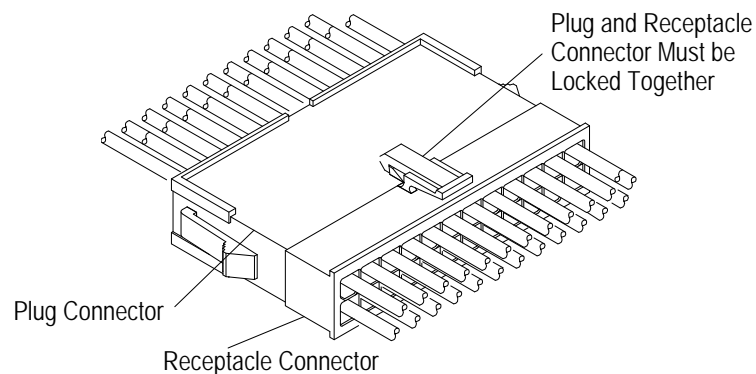

Figure 7

### 3.8. Wire Bend Radius

TE Engineering recommends that individual cables should be dressed to a bend radius of at least ten times the cable outside diameter. Likewise, cable bundles should be dressed to a bend radius of at least ten times the diameter of the bundle.

### 3.9. Panel Cutout

VAL-U-LOK Series Connector panel cutouts shall be as indicated in Figure 8. No mounting hardware is required. The plug housing features flexible mounting tabs for insertion into the panel. Push the plug connector through the panel - in the same direction as the cutout was made - until it snaps in place.

### 3.10. Header Assemblies

The pc board right-angle and vertical header assemblies are supplied with pre-installed contacts that have right-angle or vertical solder tines. They are designed to mate with connectors that have precision formed, crimp-type contacts inserted into 2- through 24-position housings. The vertical header assemblies are soldered to the pc board with or without pegs. See Figure 1.

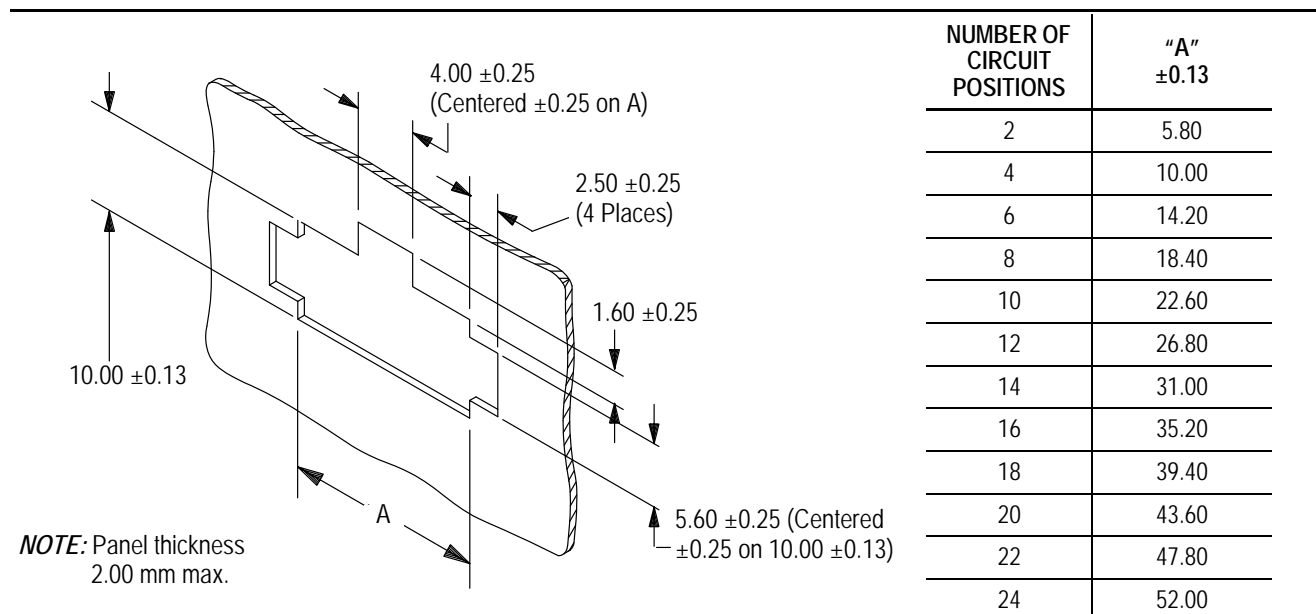

Figure 8

### 3.11. PC Board

#### A. Material and Thickness

1. Board material will be glass epoxy (FR-4, G-10).
2. Board thickness shall be 1.78 mm max.

Contact the Product Information Center or the Tooling Assistance Center number listed at the bottom of page 1 for suitability of other board materials or thicknesses.

#### B. Tolerance

Maximum allowable bow of the pc board shall be 0.03 mm over the length of the header assembly.

#### C. PC Board Layout

The mounting and contact holes in the pc board must be precisely located to ensure proper placement and optimum performance of the header assembly. Design the pc board using the dimensions provided in Figure 9. The layout shows the top (component) side of the board.



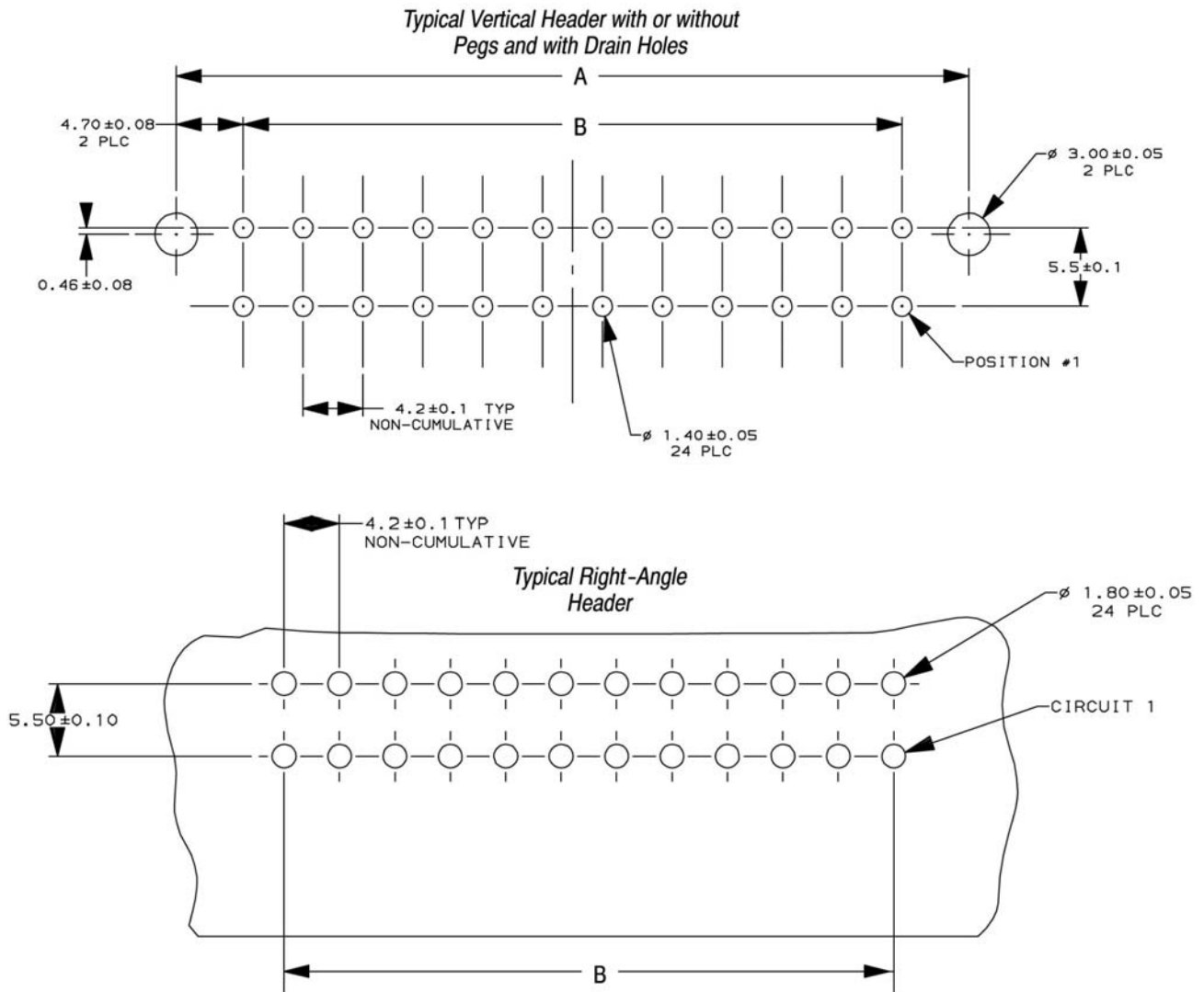

NUMBER OF CIRCUITS	DIMENSION	
	"A"	"B"
2	9.4	0.0
4	13.6	4.2
6	17.8	8.4
8	22.0	12.6
10	26.2	16.8
12	30.4	21.0
14	34.6	25.2
16	38.8	29.4
18	43.0	33.6
20	47.2	37.8
22	51.4	42.0
24	55.6	46.2

Figure 9

### 3.12. PC Board Solder Tine Holes

The holes in the pc board for the solder tines must be drilled and plated through to specific dimensions. See Figure 10.

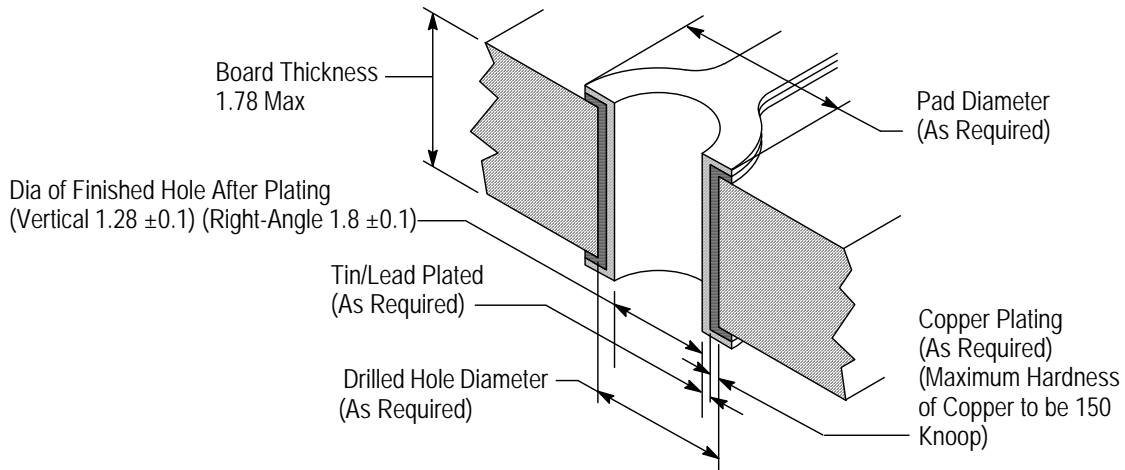

Figure 10

### 3.13. PC Board Header Assembly Placement



**CAUTION**

The header assemblies should be handled only by the housing to prevent deformation or other damage to the solder tines.

#### A. Manual Placement

Align the header assembly solder tines with the appropriate holes in the pc board. Start all solder tines into the board, then press on the header until it seats on the pc board.

#### B. Robotic Placement

The robotic equipment must be adjusted to feed, pick up, and place the headers on the pc board with an accuracy of 0.25 mm. The header assembly datum surfaces detailed on the customer drawing will ensure correct placement of the header. For information on robotic equipment, see Section 5, TOOLING.

### 3.14. Soldering

#### A. Flux Selection

Contact solder tines must be fluxed prior to soldering with a mildly active, rosin base flux. Selection of the flux will depend on the type of pc board and other components mounted on the board. Additionally, the flux must be compatible with the wave solder line, manufacturing, health, and safety requirements. Call the Product Information phone number at the bottom of page 1 for consideration of other types of flux. Some fluxes that are compatible with these header assemblies are provided in Figure 11.

FLUX TYPE	ACTIVITY	RESIDUE	COMMERCIAL DESIGNATION	
			KESTER	ALPHA
RMA (Mildly Activated)	Mild	Noncorrosive	186	611

Figure 11

#### B. Soldering Guidelines

VAL-U-LOK Series Header Assemblies can be soldered using a variety of soldering techniques. The temperatures and exposure time shall be within the ranges specified in Figure 12. We recommend using SN60 or SN62 solder for these header assemblies.



**NOTE**

Manual 402-40 provides some guidelines for establishing soldering practices. Refer to Paragraph 2.4, Manuals.

KESTER and ALPHA are trademarks of their respective owners.

SOLDERING PROCESS	TEMPERATURE	TIME (At Max Temperature)
Wave	260°C [500°F] (Wave Temperature)	5 Seconds

Figure 12

### C. Cleaning

After soldering, removal of fluxes, residues, and activators is necessary. Consult with the supplier of the solder and flux for recommended cleaning solvents. The following is a listing of common cleaning solvents that will not affect the header assemblies for the time and temperature specified. See Figure 13.



#### DANGER

Consideration must be given to toxicity and other safety requirements recommended by the solvent manufacturer. Refer to the manufacturer's Material Safety Data Sheet (MSDS) for characteristics and handling of cleaners. Trichloroethylene and Methylene Chloride can be used with no harmful affect to the header assemblies; however TE does not recommend them because of the harmful occupational and environmental effects. Both are carcinogenic (cancer-causing) and Trichloroethylene is harmful to the earth's ozone layer.



#### NOTE

If you have a particular solvent that is not listed, contact the Tooling Assistance Center or Product Information number at the bottom of page 1.

CLEANER		TIME (Minutes)	TEMPERATURE (Maximum)
NAME	TYPE		
ALPHA 2110	Aqueous	1	132°C [270°F]
BIOACT EC-7	Solvent	5	100°C [212°F]
Butyl CARBITOL	Solvent	1	Ambient Room
Isopropyl Alcohol	Solvent	5	100°C [212°F]
KESTER 5778	Aqueous		
KESTER 5779	Aqueous		
LONCOTERGE 520	Aqueous		
LONCOTERGE 530	Aqueous		
Terpene	Solvent		

Figure 13

### D. Drying

When drying cleaned assemblies and printed circuit boards, make certain that temperature limitations are not exceeded: 105°C [221°F] max for a period of 5 minutes for standard temperature products. Excessive temperatures may cause header assembly degradation. Values may vary with different types of automatic cleaning equipment. See the equipment manufacturers recommendations.

#### 3.15. Checking Installed Header Assemblies

The header assemblies must be seated on the pc board to the dimensions shown in Figure 14.

#### 3.16. Polarization

The configuration of the VAL-U-LOK Series Connector mating cavities prevents accidental inversion when mating the two components.

#### 3.17. Mating of Connectors

To ensure a proper circuit connection, the receptacle connector latch must fully engage the header assembly locking ramp.

ALPHA, BIOACT, CARBITOL, LONCOTERGE, and KESTER are trademarks of their respective owners.

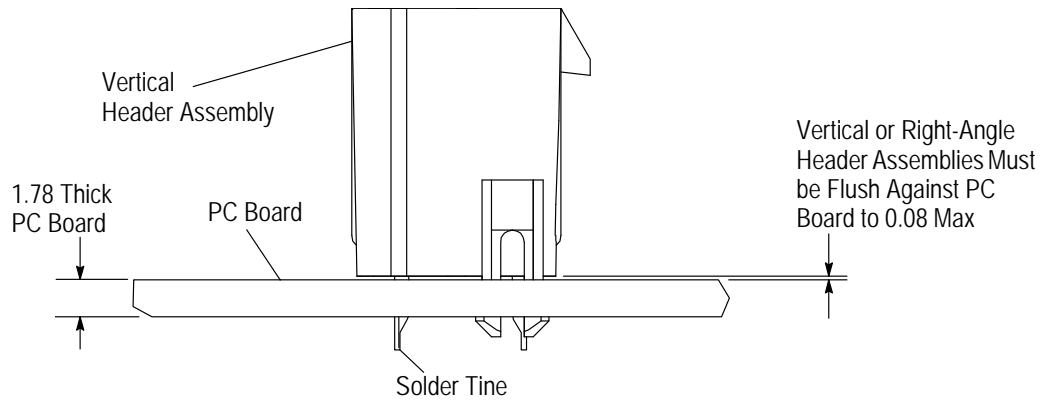

Figure 14

### 3.18. Header Assembly Spacing

Care must be used to avoid interference between adjacent header assemblies and/or other components. If robotic equipment is used, space allowances will be required for the grippers.

### 3.19. Repair/Removal

Use an extraction tool to remove individual contacts from connectors for replacement or for relocation to another housing cavity. Extraction Tool 1586343-1 is used to extract contacts. See Figure 15. Reset the locking lances to the original spread before reusing contacts. Damaged or worn contacts may be replaced provided there is sufficient slack, after rest ripping the wire, to insert the new contact into the connector. Refer to Section 5, TOOLING. Damaged pc board header assemblies may be removed from the pc board by standard de-soldering methods.

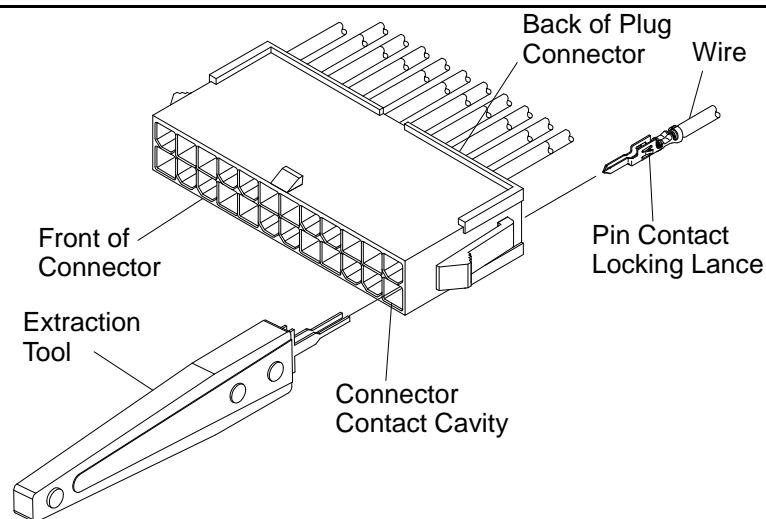

Figure 15

## 4. QUALIFICATIONS

The VAL-U-LOK Series Headers and Connectors are Recognized by Underwriters Laboratories Inc. (UL) in File E28476 and Certified to CSA International in File LR7189.

## 5. TOOLING

A listing of tooling recommendations covering the full wire size range is provided in Figure 16. The listing includes hand tools for manual application of loose piece contacts, and semi-automatic and automatic machines for power assisted application of strip form contacts. Modified designs and additional tooling concepts may be available to meet other application requirements. For additional information, contact one of the service groups at the bottom of page 1.



**NOTE**

TE Tool Engineers have designed machines for a variety of application requirements. For assistance in setting up prototype and production line equipment, contact Tool Engineering through your local TE Representative or call the Tooling Assistance Center number at the bottom of page 1.

**• Hand Crimping Tools**

Hand crimping tools that accommodate the full wire size range are designed for prototype and low-volume applications such as repair of damaged contacts.

**• Applicators**

Applicators are designed for the full wire size range of strip-fed, precision formed contacts, and provide for high volume, heavy duty production requirements. The applicators can be used in bench or floor model power units.



**NOTE**

Each applicator is shipped with a metal identification tag attached. DO NOT remove this tag or disregard the information on it. Also, a packet of associated paperwork is included in each applicator shipment. This information should be read before using the applicator; then it should be stored in a clean, dry area near the applicator for future reference. Some changes may have to be made to the applicators to run in all related power units. Contact the Tooling Assistance Center number at the bottom of page 1 for specific changes.

**• Power Units**

A power unit is an automatic or semi-automatic device used to assist in the application of a product. Power unit includes the power source used to supply the force or power to an applicator.

**• Robotic Equipment**

Robotic equipment for placement of the header assemblies on a pc board must have a true position accuracy of 0.25 mm to ensure proper location and insertion of the solder tines. This includes gripper and fixture tolerances as well as equipment repeatability. It must use the assembly datum surface to ensure reliable header placement.

**• PC Board Support**

A customer supplied pc board support must be used to prevent bowing of the pc board during insertion of the headers. It should have a flat surface with holes or a channel large enough to receive the solder tines during installation.

**• Extraction Tools**

Extraction Tools are designed to release the contacts inside the receptacle connector without damaging the housing or contacts. Refer to Paragraph 3.19.

WIRE SIZE mm <sup>2</sup> [AWG]	INSULATION DIA RANGE	APPLICATION TOOLING (DOCUMENT)			
		APPLICATOR	POWER UNIT	HAND TOOL	EXTRACTION TOOL
0.12-0.30 [26-22]	1.19-1.75	1852703-1 (408-8040)	356500-1, -2 (409-5878)	91387-1 (408-8917)	1586343-1 (N/A)
		1852703-2 (408-8040)	3545000-1 (409-5842) 565435-[ ] (409-5128)		
		1852703-3 (408-8040)	354500-[ ] (409-5842)		
0.20-0.80 [24-18]	1.50-3.10	1852668-1 (408-8040)	356500-1, -2 (409-5878)	91388-1 (408-8918)	
		1852668-2 (408-8040)	354500-1 (409-5842) 565435-[ ] (409-5128)		
		1852668-3 (408-8040)	354500-[ ] (409-5842)		
1.2 [16]	1.80-3.10	1852294-1 (408-8040) 1852294-2 (408-8040) 1852294-3 (408-8040)	356500-1, -2 (409-5878) 565435-[ ] (409-5128) 354500-[ ] (409-5842)	1976444-1 (N/A)	

Figure 16 (Cont'd)

AMP-O-LECTRIC  
Model "G" Terminating  
Machine 354500-[ ]

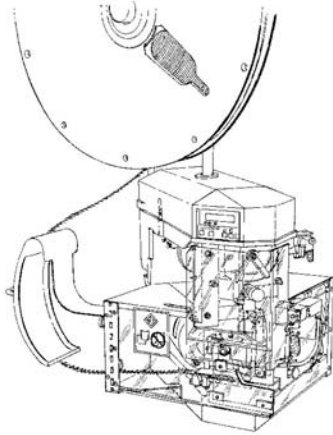

PC Board Support  
(Customer Supplied)

Holes (Ref)

Channel (Ref)

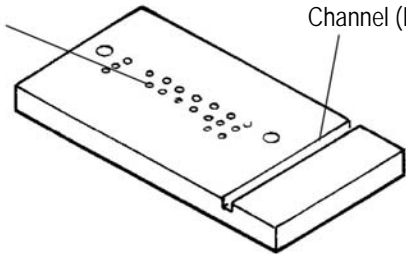
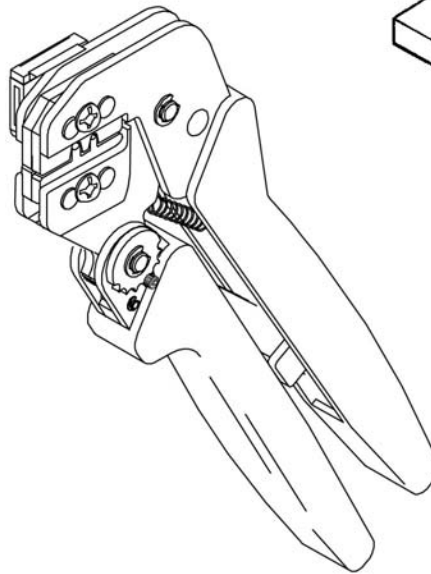

PRO-CRIMPER III Hand  
Tool 91387-1, 91388-1  
or 1976444-1

AMP-O-LECTRIC  
Model "K" Terminating  
Machine 565435-[ ]

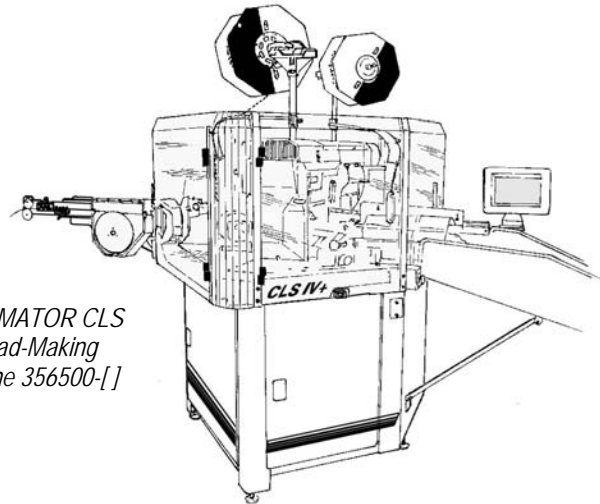
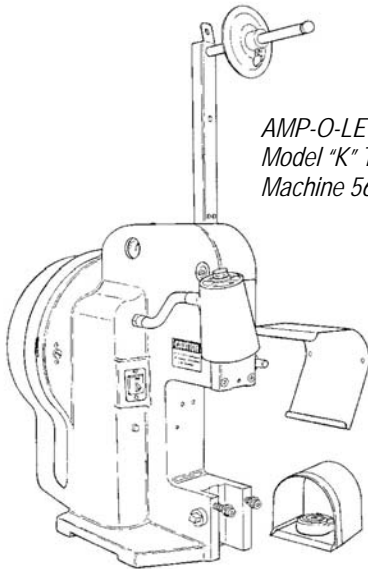

AMPOMATOR CLS  
IV+ Lead-Making  
Machine 356500-[ ]

Heavy Duty Miniature  
Quick-Change Side  
Feed Applicator (Typ)

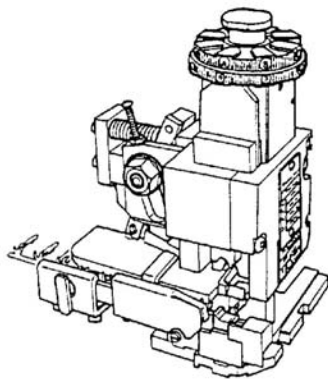

Extraction Tool  
1586343-1

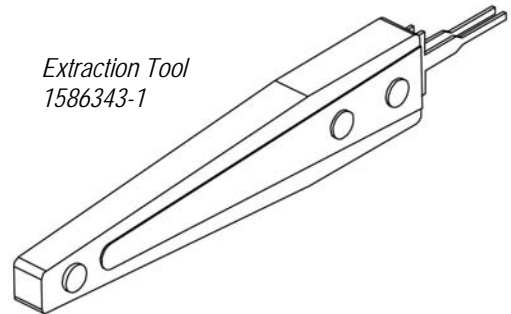
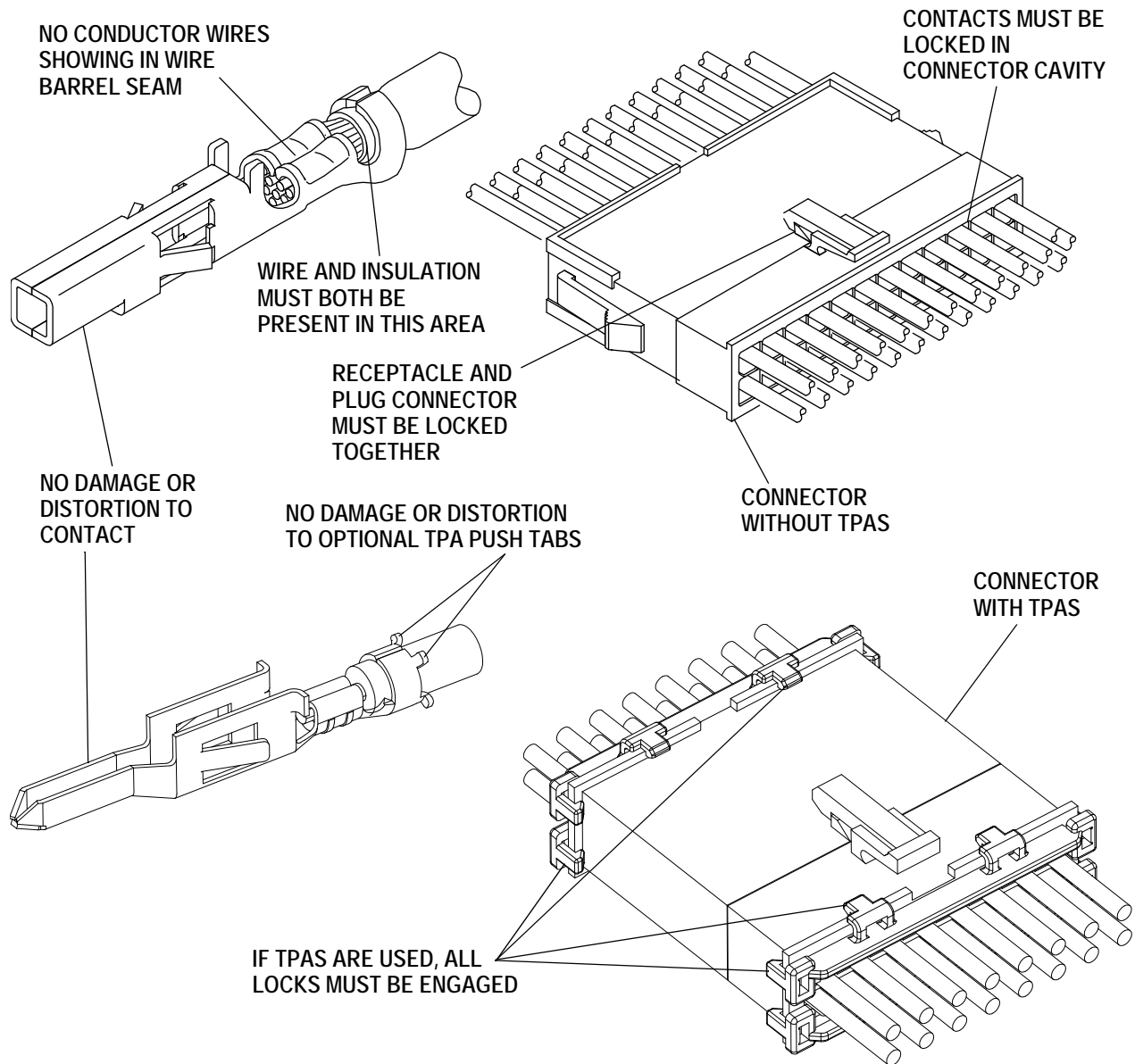

Figure 16 (End)

### 6. VISUAL AID

The illustration below shows a typical application of this product. This illustration should be used by production personnel to ensure a correctly applied product. Applications which DO NOT appear correct should be inspected using the information in the preceding pages of this specification and in the instructional material shipped with the product or tooling.



**FIGURE 17. VISUAL AID (CONT'D)**

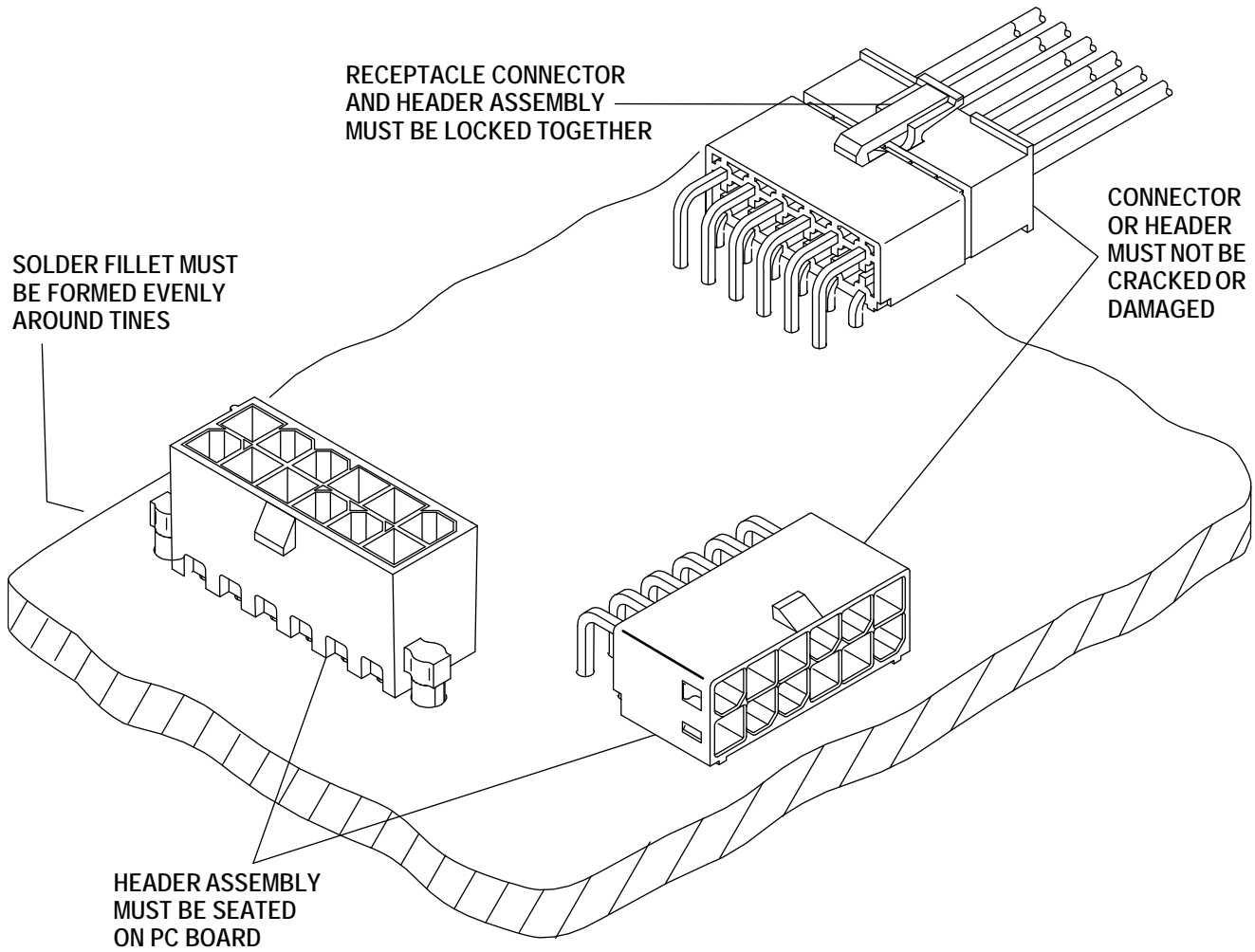

**FIGURE 17. VISUAL AID (END)**