

THIS DRAWING IS UNPUBLISHED. RELEASED FOR PUBLICATION
 © COPYRIGHT BY TYCO ELECTRONICS CORPORATION. ALL INTERNATIONAL RIGHTS RESERVED.

LOC	DIST	REVISIONS					
FT	0	P	LTR	DESCRIPTION	DATE	DWN	APVD
		S		REVISED PER ECO-09-009260	07MAY09	HMR	MS

- 1 PARTS PACKAGED UNASSEMBLED.
- 2 CABLE CLAMPING AREA ADJUSTABLE FROM .100 TO .410 SQ IN BY REVERSING CLAMPING INSERTS. (2 INSERTS SUPPLIED)
- 3 CABLE CLAMPING AREA ADJUSTABLE FROM .100 TO .410 SQ IN BY CHANGING CLAMPING INSERTS. (4 INSERTS SUPPLIED, -3 ONLY)
- 4 .703 MAXIMUM CABLE OUTSIDE DIAMETER.
- 5 BULK PACKAGED KITS TO BE ORDERED IN MULTIPLES OF 100 ONLY.
- 6 SCREW FINISH ZINC WITH NON-HEXAVALENT CHROMATE.

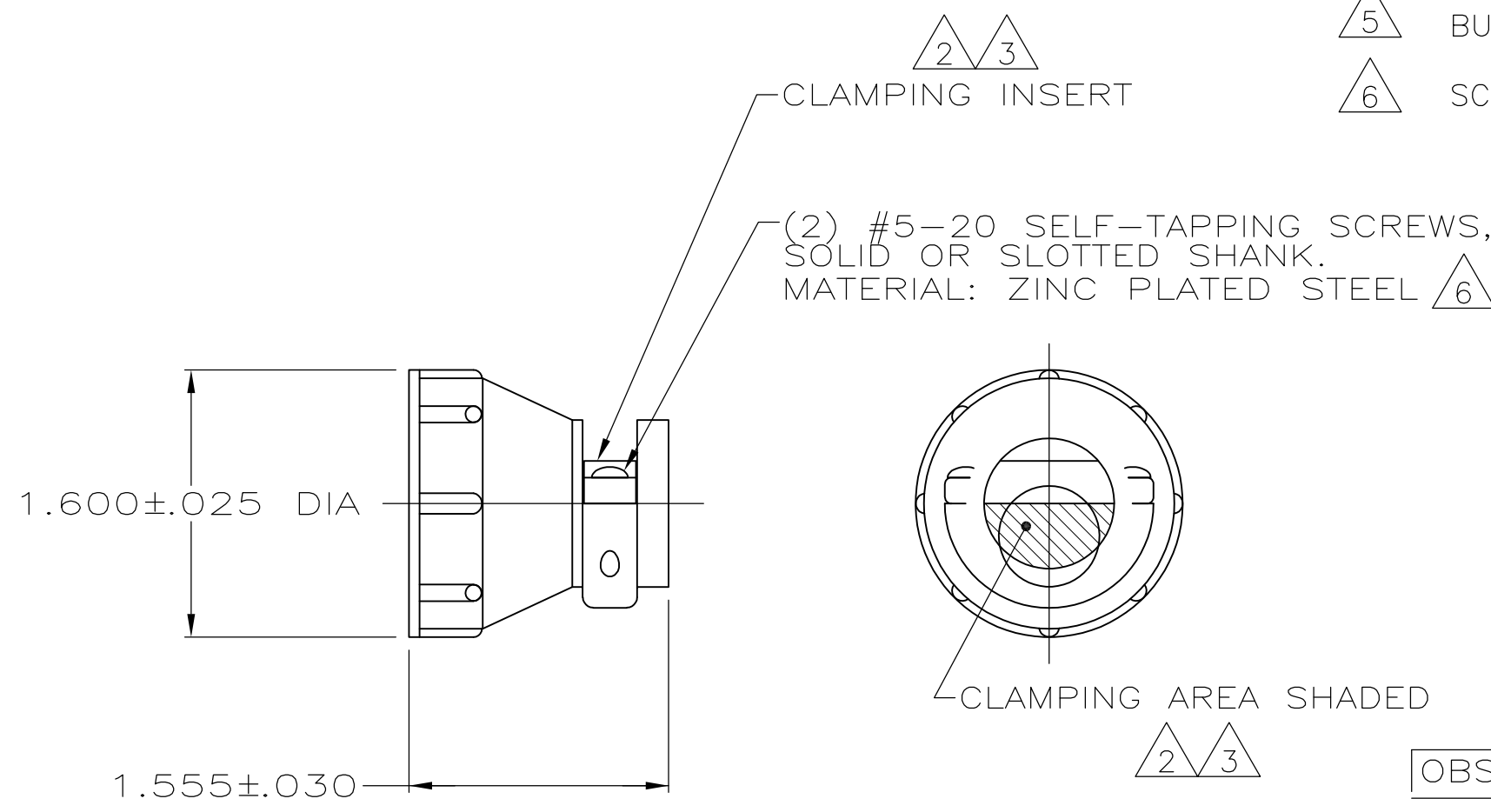

2	.75 ^{±.00} / _{-.05}	INDIVIDUAL	1-206138-2
2	.75 ^{±.00} / _{-.05} / .62 ^{±.00} / _{-.05}	INDIVIDUAL	1-206138-1
2	.62 ^{±.00} / _{-.05}	5 BULK	1-206138-0
2	.62 ^{±.00} / _{-.05}	SMALL PACK	206138-9
2	.62 ^{±.00} / _{-.05}	INDIVIDUAL	206138-8
2	.75 ^{±.00} / _{-.05} / .62 ^{±.00} / _{-.05}	INDIVIDUAL	206138-7
	.62 ^{±.00} / _{-.05}	SMALL PACK	206138-6
	OBSOLETE	5 BULK	206138-3
2	.62 ^{±.00} / _{-.05}	5 BULK	206138-2
2	.62 ^{±.00} / _{-.05}	INDIVIDUAL	206138-1
	SCREW LENGTH	PACKAGING	PART NUMBER

THIS DRAWING IS A CONTROLLED DOCUMENT.		DWN A GRAFF 4/23/91	Tyco Electronics Corporation Harrisburg, PA 17105-3608	
DIMENSIONS: INCHES		CHK W.G.LENKER 7-22-92	NAME CABLE CLAMP KIT, STANDARD, SHELL SIZE 23, CPC	
TOLERANCES UNLESS OTHERWISE SPECIFIED:		APVD -	PRODUCT SPEC 108-10024	
0 PLC ± -		PRODUCT SPEC	APPLICATION SPEC	RESTRICTED TO
1 PLC ± -		108-10024	SIZE	CAGE CODE
2 PLC ± -		APPLICATION SPEC	A3	00779
3 PLC ± -		APVD	DRAWING NO	G-206138
4 PLC ± -		WEIGHT	SCALE	SHEET
ANGLES ± -		-	NTS	1 OF 1
MATERIAL THERMOPLASTIC		FINISH -	CUSTOMER DRAWING	REV S