

# 1.7 Peristaltic Pumps DULCO®flex

## 1.7.1 Peristaltic Pump DULCO®flex DF2a



The optimum pump product range for use in swimming pools, hot tubs, and spa zones.

Capacity range 0.4 – 2.4 l/h at max. 1.5 bar back pressure



The peristaltic pump DULCO®flex DF2a meters chemicals functionally, cost-effectively and quietly – ideal for use in swimming pools, hot tubs, and in spa and wellness facilities.

The feed chemical is transported by the rotor squeezing the hose in the direction of flow. This explains why there is no need for valves. The feed chemical is thus handled with care. Typical applications: wherever lower pump pressure is sufficient. For example when metering conditioners in private pools.

### Your benefits

- Smooth inner wall reduces deposits.
- Hose materials: PharMed® or Viton®
- Virtually silent operation
- Simple handling
- Enhanced service life of the hose due to spring-loaded rollers, which keep the rolling pressure constant
- Robust and protected against spray water from all sides: Housing made of impact-resistant and chemical-resistant PPE

### Technical details

- Self-priming against max. 1.5 bar
- Control or flow control via ON/OFF power supply
- Degree of protection IP 65
- OEM versions on request

### Field of application

- Meters conditioners in private pools
- Meters belt lubricants in bottling machines
- Meters cleaning agents in dishwashers



pk\_1\_130

### Dimensional drawing of DULCO®flex DF2a

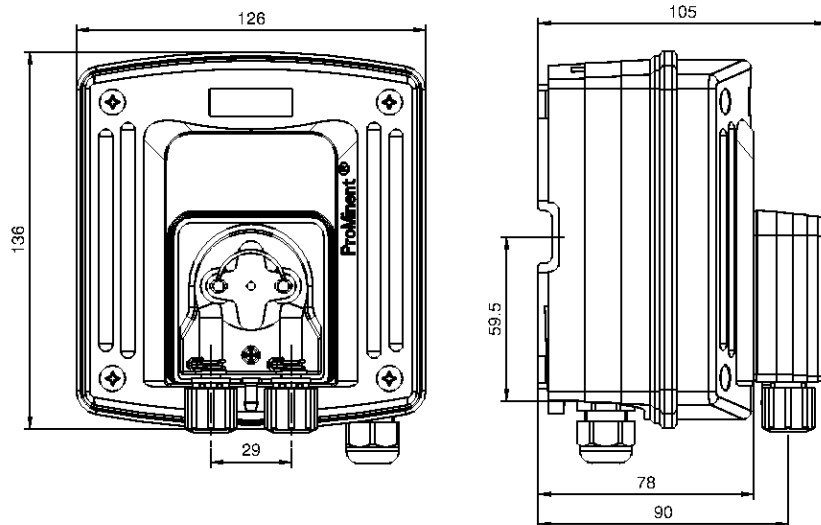

P\_DX\_0051\_SW3

Dimensional drawing of DULCO®flex DF2a - dimensions in mm



# 1.7 Peristaltic Pumps DULCO®flex

## 1.7.2 Identity Code Ordering System

### DULCO®flex product range, version DF2a

DF2a	Type	Capacity
		<b>bar</b> <b>l/h</b>
	0204	1.5    0.4
	0208	1.5    0.8
	0216	1.5    1.6
	0224	1.5    2.4
<b>Hose material</b>		
	P	PharMed®
	V	Viton® for fragrances (special version)
<b>Version</b>		
	0	With ProMinent® logo
	1	Without ProMinent® logo
<b>Hydraulic connectors</b>		
	0	Connector for hose 6/4 mm suction and discharge side
	9	Connector for hose 10/4 mm discharge side only
<b>Power supply</b>		
	A	230 V ± 10%, 50/60 Hz
<b>Cable and plug</b>		
	0	No mains lead
	1	With 2 m mains lead, open ended
	A	With mains cable, European plug
<b>Drive</b>		
	0	Mains ON/OFF
<b>Installation</b>		
	W	Wall mounted
<b>Accessories</b>		
	0	No accessories

Viton® and PharMed® are registered trademarks.

### Technical Data

Type	Capacity		Frequency rpm	Connector size o dia. x i dia.	Suction lift mWC	Intake head m WC
	bar	l/h				
0204	1.5	0.4	5	6x4/10x4	4	3
0208	1.5	0.8	10	6x4/10x4	4	3
0216	1.5	1.6	20	6x4/10x4	4	3
0224	1.5	2.4	30	6x4/10x4	4	3

Admissible ambient temperature: 10-45 °C  
 Power consumption approx.: 5 W  
 Switching duration: 100%  
 Enclosure rating: IP 65

All data refers to water at 20 °C.

### Spare Hoses

	Order no.
Spare hose set, complete, PharMed®	1009480
Replacement hose compl. Viton®	1023842

