

規格承認書

PECIFICATION FOR APPROVAL

客戶
CUSTOMER : _____
項目
ITEM : 电磁无源分体蜂鸣器 (外部驱动)
型號
TYPE : GMC12085YAS-8-120R2048 通用型 (电阻 8-120 欧)
描述
DESCRIPTION : 12 x 8.5MM 2048Hz 8-120 Ω >=80DB ABS 材质 光头蜂鸣器
客戶料號
CUSTOMER NO. : _____
規格書號
SPECIFICATION NO.: _____
版本
EDITION NO. : V1.
日期
DATE : 20

客戶承認

CUSTOMER CONFIRM AND SIGN

檢查 TESTED BY	審核 CHECKED BY	承認 APPROVED BY

東莞市贏海電子有限公司

DONGUAN INGHAI ELECTRONICS CO.,LTD

製作 ISSUED BY	審查 CHECKED BY	確認 APPROVED BY
周明	李林	

地址：廣東省東莞市長安鎮上沙管理區北橫路 8 號

電話 / TEL: 0769-83060958 傳真 / FAX: 0769-81608993

網址: HTTP://WWW.INGHAI.COM

DONGGUAN INGHAI ELECTRONICS CO.,LTD

Model NO: GMC12085YAS-8-120R2048

DIMENSIONS Unit:mm Tolerance: ± 0.5

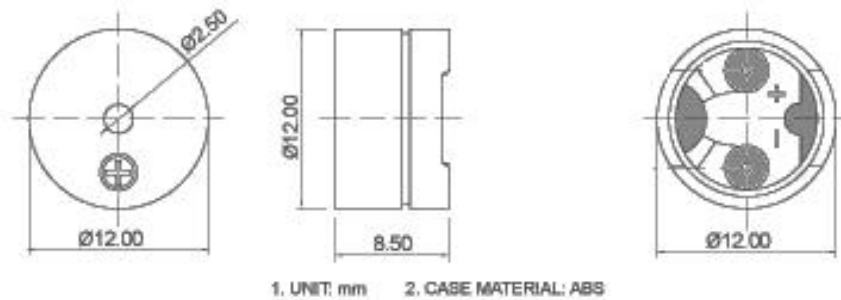

SPECIFICATIONS

Model NO	GMC12085YAS
Rated Voltage	1.5-12V
Operating Voltage	1.5 ~12V
Max.Rated Current	Max.80 mA
Coil Resistance	8-120 $\pm 4 \Omega$
Sound Pressure level(dB/)at10cm	Min.80dB
Resonant Frequency	2048Hz
Operating Temperature	-20 °C ~+60 °C
Storage Temperature	-20 °C ~+70 °C
Case material and color	ABS / Black

Measuring condition

Part shall be measured under a condition (Temperature: 5 ~ 35°C, Humidity: 45% ~ 85%R.H., Atmospheric pressure: 860 ~ 1060hPa) unless the standard condition (Temperature: 25 \pm 3°C, Humidity: 60 \pm 10%R.H. Atmospheric pressure: 860 ~ 1060hPa) is regulated to measure.

备注：适用于手工焊接

Acoustic Characteristics:

The oscillation frequency, current consumption and sound pressure are measured by the

measuring instruments shown below

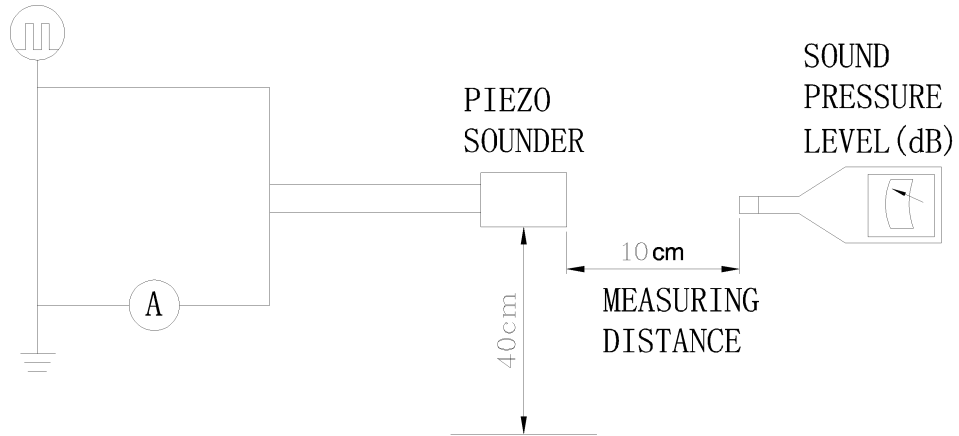

In the measuring test, buzzer is placed as follows:

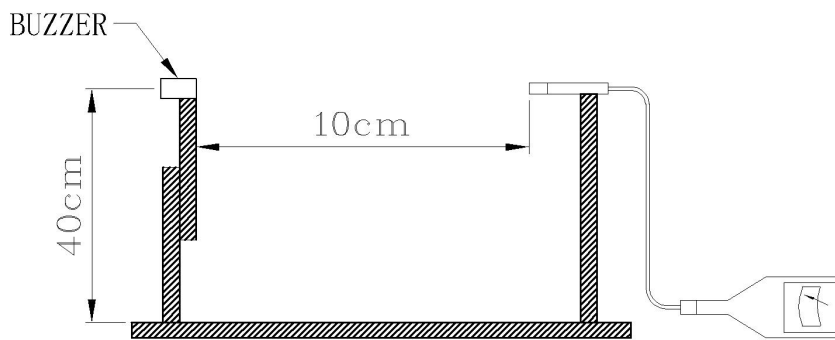

Typical Frequency Response Curve

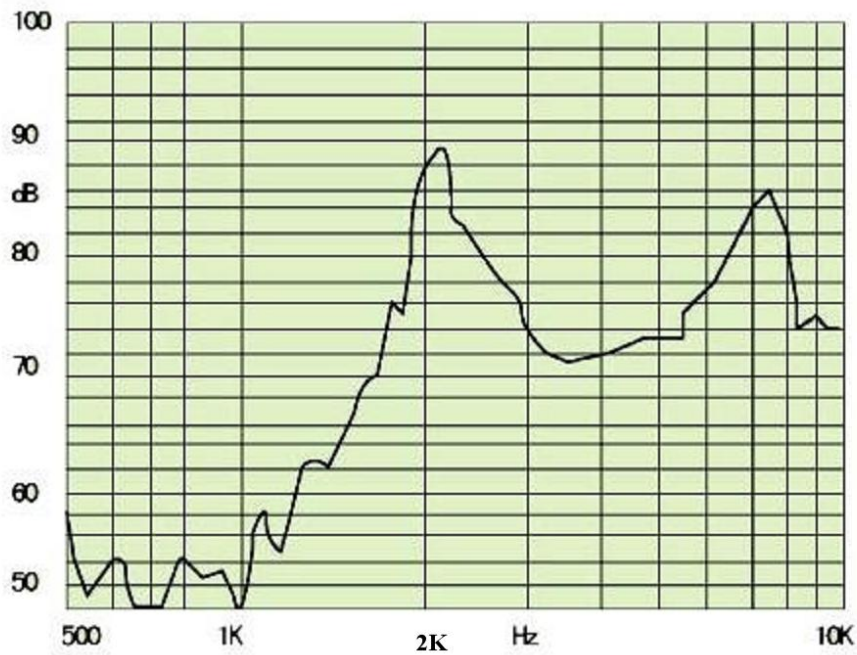

C: Reliability Test

After any following tests the part shall meet specifications without any degradation in

appearance and performance except SPL. SPL shall not deviate more than -10 dB from the initial value

1. Ordinary Temperature Life Test

The part shall be subjected to 96 hours at $25 \pm 10^{\circ}\text{C}$. Input rated voltage Resonant frequency, 1/2 duty Square wave.

2. High Temperature Test

The part shall be capable of with standing a storage temperature of $+70^{\circ}\text{C}$ for 96 hours.

3. Low Temperature Test

The part shall be capable of with standing a storage temperature of -30°C for 96 hours.

4. Humidity Test

Temperature: $+40^{\circ}\text{C} \pm 3^{\circ}\text{C}$ Relative Humidity: 90% ~ 95% Duration: 48 hours and expose to room temperature for 6 hours

5. Temperature Shock Test

Temperature: 60°C /1hour \rightarrow 25°C /3hours \rightarrow -30°C /1hour \rightarrow 25°C /3hours (1cycle)
Total cycle: 10 cycles

6. Drop Test

Standard Packaging From 120mm (Drop on hard wood or board of 5cm thick, three sides, six plain.)

7. Vibration Test

Vibration: 1000cycles /min. Amplitude: 1.5mm, Duration: 1 hour in each 3 axes

Note:

As this product is not protected from foreign material entering, please make sure that any foreign materials (e.g. magnetic powder, washing solvent, flux, corrosive gas) do not enter this product in your production processes. The functional degradation (e.g. SPL down) may occur if foreign material enter it.