

Model 3560, 3562, 3564, 4690
Banana Jack to #12, 16, 20 & 22 Pin Socket

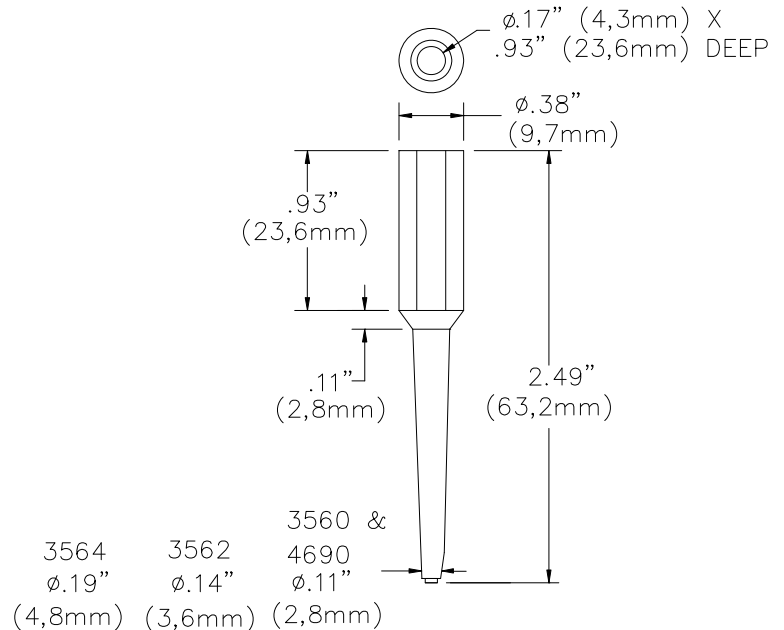

Features

- Ideal test adapters for rapid testing of the hard-to-get to pins of multi-pin connectors.
- Flexible tip allows testing of adjacent contacts.
- Full insulation protects against shorting or contact damage.
- Model 4690 will also slip over 0.025" (0.63mm)

Materials

Insulation: Polyvinyl Chloride (PVC)
 Banana Jack Body (upper connector)
Material: Brass.
Finish: Bright Tin Plated
 Socket (lower connector)
Material: Copper Alloy
Finish: Gold Plated over Copper Plating

Model	Contact Size	Type	Current
4690	22 AWG .030" (.76mm)	Socket	3 Amps
3560	20 AWG .040" (1.02mm)	Socket	
3562	16 AWG .063" (1.60mm)	Socket	
3564	12 AWG .093" (2.36mm)	Socket	

Ordering Information

Model: **3560-***, **3562-***, **3564-***, **4690-***
 * = Color: -0 Black, -2 Red
 Ordering Example: 3560-2 (red adapter)

Voltage Rating:

For *CE Compliance* and for personal safety, do not hold in hand when voltages exceed 33 Vrms/70 Vdc. Maximum voltage for *hands free use*: 2500 Vrms Max.

Operating Temperature: +55°C (+131°F) Max.

Test Kit 6481: contains 18 pieces, one red and one black adapter of each adapter: 3560, 3561, 3562, 3563, 3564, 3565, 4690, 4691 and one set of model 6358 test leads.

For banana jack to test pins, see models: 3561, 3563, 3565, 4691

USA: Sales: 800-490-2361
 Technical Support: technicalsupport@pomonatest.com
 Fax: 425-446-5844

Europe: 31-(0) 40 2675 150 **International:** 425-446-5500

Where to Buy: www.pomonaelectronics.com

All dimensions are in inches. Tolerances (except noted): .xx = ±.02" (.51 mm), .xxx = ±.005" (.127 mm). All specifications are to the latest revisions. Specifications are subject to change without notice. Registered trademarks are the property of their respective companies.

Model 3560, 3562, 3564, 4690
Banana Jack to #12, 16, 20 & 22 Pin Socket

Pomona®

The items included with this product are certified to meet IEC 1010-2-031 safety requirements.

Les éléments inclus avec ce produit sont certifiés pour répondre à des exigences de sûreté du IEC 1010-2-031.

Los items incluidos con este producto se certifican para resolver requisitos de seguridad del IEC 1010-2-031.

– Only IEC 1010 type shrouded test plugs should be used with IEC 1010 type jacks. NEVER INSERT A PROBE TIP WITH BANANA SPRING INTO A TEST ACCESSORY JACK THAT WILL BE USED AS A HAND HELD PROBING DEVICE

–Seuls les vérificateurs de tension renforcés de type IEC 1010 devraient être utilisés avec des jacks de type IEC 1010. NE JAMAIS INSERER DE BOUT DE SONDE AVEC RESSORT BANANE DANS UN JACK D'ESSAI D'ACCESSOIRES QUI SERA UTILISE COMME DISPOSITIF DE SONDAGE A MAIN.

–Se deben usar sólo tapones de prueba reforzados del tipo IEC 1010 con receptáculos de tipo IEC 1010. NUNCA INTRODUZCA UNA CLAVIJA CON UN MUELLE TIPO BANANA EN UN RECEPTACULO DE PRUEBA QUE A SU VEZ SE USE COMO APARATO DE PRUEBA MANUAL.



Both Direct and Alternating Current.
Courant Continu et Alternatif.
Corriente Directa y Alterna.



Caution ! Refer to Accompanying Documents.
Attention ! Se Reporter aux Documents joints.
¡Peligro! Consulte los Documentos Adjuntos.



Double Insulation or Reinforced Insulation.
Isolation Double ou Isolation Renforcée.
Aislamiento Doble o Aislamiento Reforzado.



Caution ! Risk of Electric Shock.
Attention ! Risque de Choc Électrique.
¡Peligro! Riesgo de Sacudida Eléctrica.

CAT

Overvoltage Category I, II, III or IV.
Surtension Catégorie I, II, III ou IV.
Sobretensión de Categoría I, II III o IV.

Pomona Electronics

PO Box 9090, Everett, WA 98206-9090 TEL: 800-490-2361

USA: Sales: 800-490-2361
Technical Support: technicalsupport@pomonatest.com
Fax: 425-446-5844

Europe: 31-(0) 40 2675 150 **International:** 425-446-5500

Where to Buy: www.pomonaelectronics.com

All dimensions are in inches. Tolerances (except noted): .xx = ±.02" (.51 mm),
.xxx = ±.005" (.127 mm). All specifications are to the latest revisions.
Specifications are subject to change without notice. Registered trademarks are
the property of their respective companies.