

Flexi-Mate 3.70mm Pitch Board-to-Board plug PCB mount



Flexi-Mate 3.70mm Pitch Board-to-Board plug, PCB mount

Pcb mount connector(503469-0200) are widely used in LED lightings. They are

Surface Mount, Right-Angle, 3.00mm Stacking Height, 2 Circuits

Flexi-Mate 3.70mm Pitch Board-to-Board plug, PCB mount

Board-to-board, wire-to-board and terminator options

Space savings and easy mating/unmating

Ensures reliable electrical connection

Used in LED TVs, LCD panels etc

Datasheet of **PCB terminal block**:

Model Number:	OL3700/T/2Y/3701R/3702P		
Brand Name:	FZOLINK	Type:	PCB to PCB /PCB to Wire connector
Rated Current:	2A DC.AC	Use:	Power/Signal/Electric
Pin spacing:	3.7mm/0.146in	Diameter of pin:	2P
Applicable Wire:	AWG 26#-30#	Terminal:	Phosphor bronz
Housing:	Nylon66 UL94V-0	Wafer:	LCP UL94V-0

Our **PCB mount connectors** can replace for Molex connector's part no as following:

503471-0200 5034710200

503473-0200 5034730200

503469-0200 5034690200

drawing of PCB terminal block:

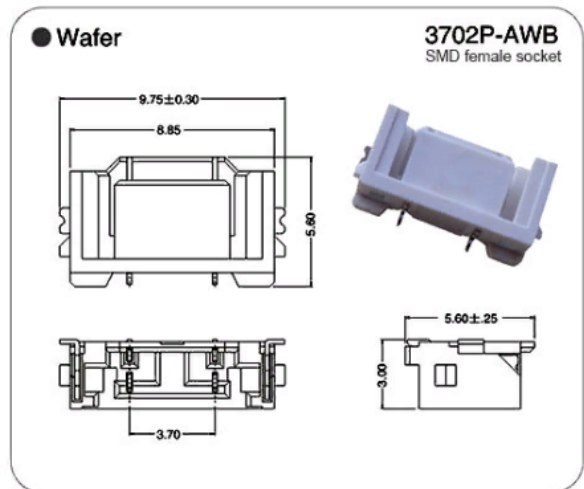
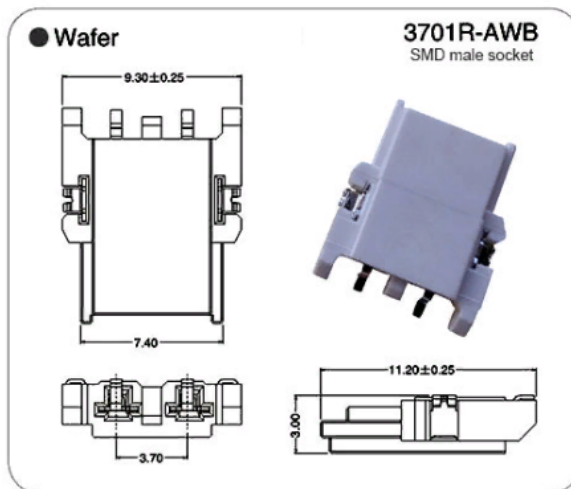
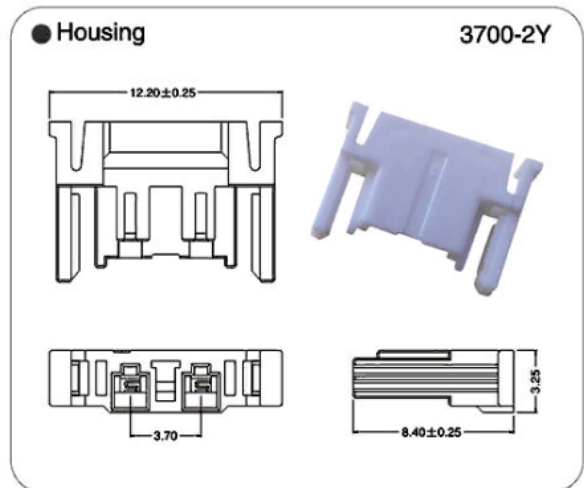
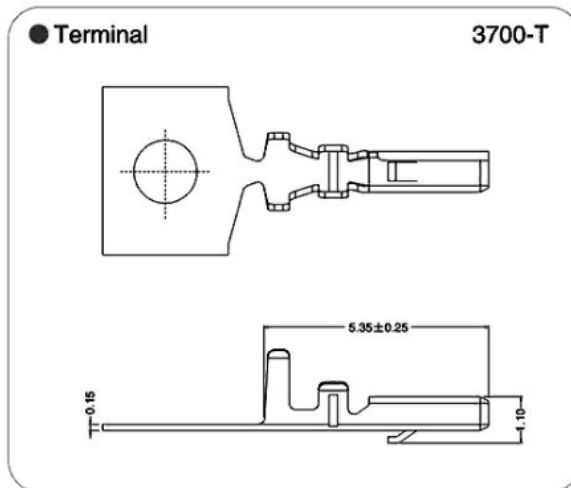

Connection Type of pcb to pcb connector:

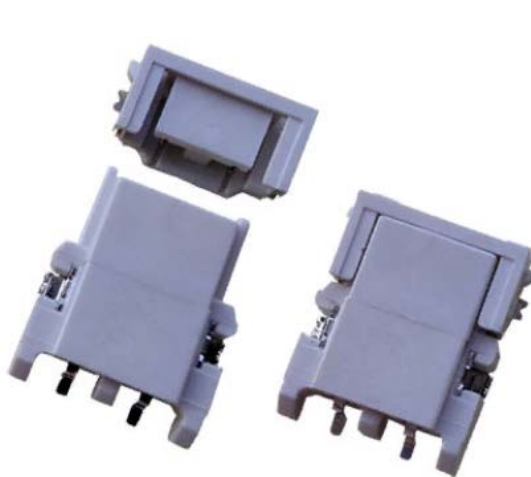

37001R+3702P (PCB to PCB)



3700-T+2Y+3702P (Wire to PCB)