



Beam Break Kit Userguide

Product Overview

Thank you for purchasing the Beam Break Kit by Global Laser. It contains the transmitting and receiving components required to build a laser beam break system – a technology that senses motion by detecting objects passing through a beam of light. To complete the system all you need to do is supply a DC voltage to each component and align the transmitted beam with the receiver optic.

If you have any queries or require help when using the Beam Break Kit then please call us on +44 (0)1495 212213 or email us at sales@globallasertech.com or contact your local representative.



Operating the Transmitter

1. Connect flying leads as in the table below.
2. The transmitter is self-pulsing, that is, it automatically modulates the beam at a frequency matched with the receiver on power up.

Laser Pin	Lead	Connection
1	Red	+5V Supply
2	Black	0

Operating the Receiver

1. Connect flying leads as in the table below
2. A white LED indicator illuminates when the receiver captures a signal from the transmitter
3. Pin 4 of the detector outputs a TTL logic low signal (0 V). Otherwise, pin 4 of the detector outputs a TTL logic high signal (5 V).
4. This output can be monitored with a test instrument (e.g. oscilloscope), or used to trigger an alarm or switch in your circuit.

Detector Pin	Lead	Connection
1	Red	+5V Supply
2	Black	0
3	Yellow	None (leave floating)
4	Blue	TTL Signal Out

Aligning the Transmitter & Receiver

If operating the Beam Break Kit over a large distance then we suggest one person stands at each end of the beam.

Aim the laser in its mount so that the beam strikes the receiver optic. The receiver has a 160° acceptance angle, so it does not need to be perfectly in line.

If the white LED indicator installed at the rear of the receiver illuminates then receiver is detecting a signal and the beam is aligned.

Cleaning The Optics

If the laser dot becomes fuzzy or unclear, please check the following:

1. Check the laser is in focus.
2. Remove contaminants with a compressed air duster.
3. Contact Global Laser or your local representative if you still have issues.

Note: Handle optics with care using powder-free latex or nitrile gloves. These prevent the transfer of oils and debris from hands to optics. Please place the protective cap over the aperture when the laser is not in use to reduce optical contamination.

Focus Adjustment

If the beam appears to be aligned but the receiver does not detect a signal, then you may need to focus the beam at the required distance to increase the incident power density. You can adjust the focus of the transmitter as follows:

1. Insert the supplied focus key into the threaded laser barrel and align with focus control grooves.
2. Turn the focus key until your desired focus is achieved.

Safety & Classification

Our products are compliant to IEC 60825-1 2014 standards. The laser included with the Beam Break Kit falls within one of the following classifications depending on output power (see spec table).

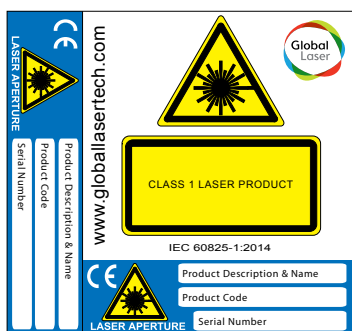

Class 1 Laser Label

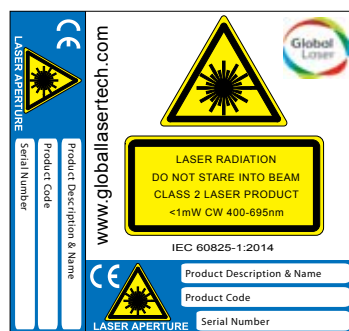

Class 2 Laser Label

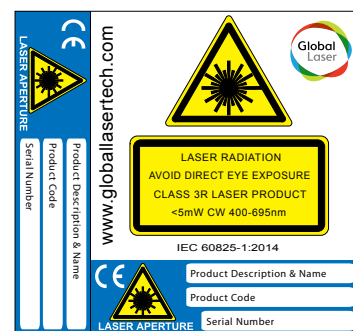

Class 3R Visible Laser Label

Mounting & Heatsinking

The lifetime and stability of your laser can be optimised when mounted on a suitable heat sink. This allows the case temperature to be kept within its specified range. Failure to properly heat sink your laser device could result in shortened lifetime or failure of the diode. As a general guideline, the lifetime of a laser diode decreases by a factor of two (approx.) for every 10°C increase in operating temperature.

There are three mounting clamps available for the transmitter and receiver: heavy duty clamp (with/without magnetic base), swivel clamp, and pillow block bearing mount.

Mounting in the Pillow Block Bearing Mount (See drawing C)

1. Secure the mount to your workbench or surface using the 20 x 11 mm oval slots in the base
2. Unscrew the M6 or M8 socket head screws to remove the clamp from the base
3. Separate the black mounting cylinder from the spherical rolling element
4. Insert your laser into the mounting cylinder
5. Replace both halves of the spherical rolling element around the cylinder and hold in place
6. Position the spherical rolling element and mounting cylinder in the curved section of the clamp and hold in place
7. Replace the other half of the clamp and hold in place
8. Screw the M6 or M8 socket head screws through the clamp and into the base
9. Manually adjust the direction of your laser

Mounting in the Heavy Duty Mounting Clamp (See drawing D)

1. Secure the clamp to a surface. There are two methods:
Screw an M5 stud to the bottom of the base, or
Remove the base by removing 2 x grub screw B with the supplied Allen key, then thread an M5 cap screw through the top of the base. Then re-attach the base to the body of the clamp
2. Loosen Allen screw A with the supplied Allen key
3. Slide your laser into the mounting hole and then tighten Allen screw A
4. Loosen grub screw A
5. Adjust the vertical angle of your laser and then tighten grub screw A
6. Loosen 2 x grub screw B. This will allow the main body of the mount to be rotated independently of the base
7. Adjust the horizontal angle of your laser and then tighten 2 x grub screw B

Mounting in the Heavy Duty Mounting Clamp with Magnetic Base (See drawing D&E)

1. Secure the magnetic base to the Heavy Duty Clamp
Screw the stud on the top of the magnetic base into the centre hole at the bottom of the Heavy Duty Clamp
2. Remove the keeper from the magnetic base and place on a ferrous surface
3. Loosen Allen screw A with the supplied Allen key
4. Slide your laser into the mounting hole and then tighten Allen screw A

5. Loosen grub screw A
6. Adjust the vertical angle of your laser and then tighten grub screw A
7. Loosen 2 x grub screw B. This will allow the main body of the mount to be rotated independently of the base
8. Adjust the horizontal angle of your laser and then tighten 2 x grub screw B

Mounting in the Swivel Mounting Clamp (See drawing F)

1. Secure the mounting base to a surface
You can use 2 x Ø9 mm slots, 4 x Ø4.5 mm holes, and/or 2 x Ø3.5 mm countersunk holes to achieve this. If mounting via Ø3.5mm countersunk holes, the swivel bracket must be removed from the base and then reattached after mounting.
2. Loosen Allen screw A (M3)
3. Slide your laser into the mounting hole and then tighten Allen screw A
4. Loosen Allen screw B (M5)
5. Adjust tilt angle and then tighten Allen screw B
6. Loosen 2 x M4 screws attaching swivel bracket to base
7. Adjust swivel angle and then tighten 2 x M4 screws

Warranty & Repair

The Beam Break Kit is supplied with a 12 month parts and labour warranty. Our manufacturing operations are certified to ISO9001.

If your product develops a fault within 12 months from the date of purchase Global Laser will repair / replace the product. If you wish to return a faulty product contact your local representative or Global Laser to obtain a RMA (Return Material Authorisation code) and return to the address below:

Global Laser Ltd
Unit 9-10
Roseheyworth Business Park
Abertillery
Gwent, NP13 1SP
United Kingdom

Mechanical Dimensions

A) Varilite Laser

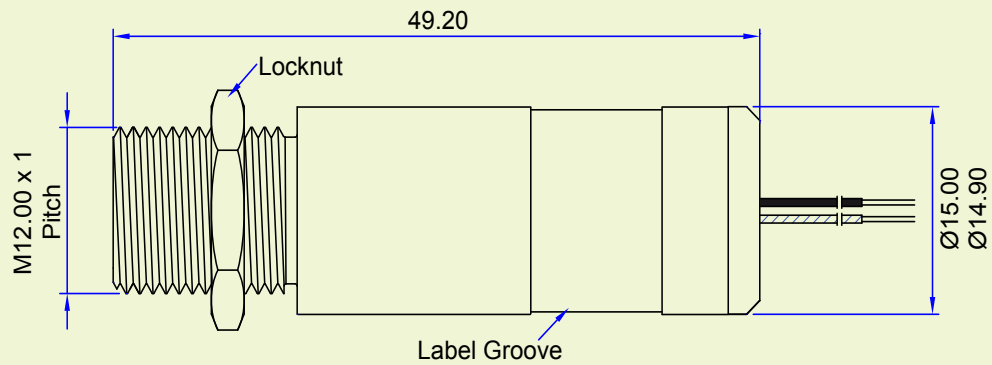

B) Synchronous Detector

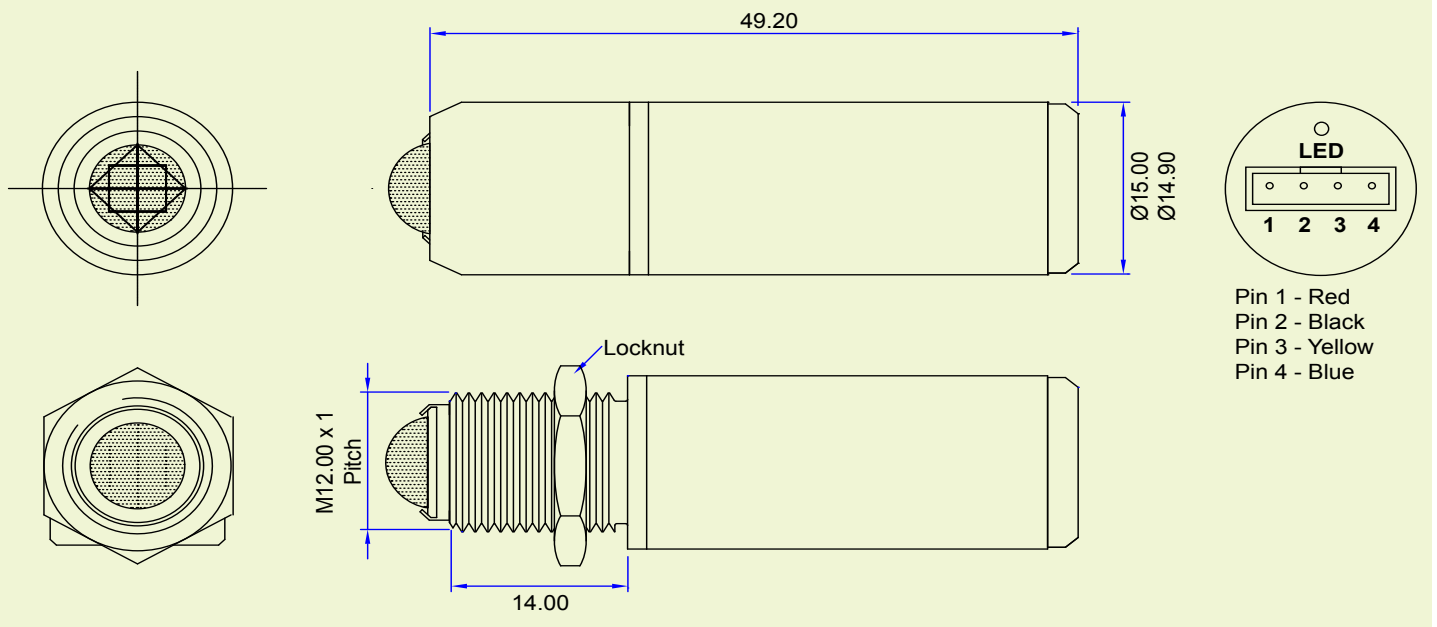

C) Pillow Block Bearing Mount

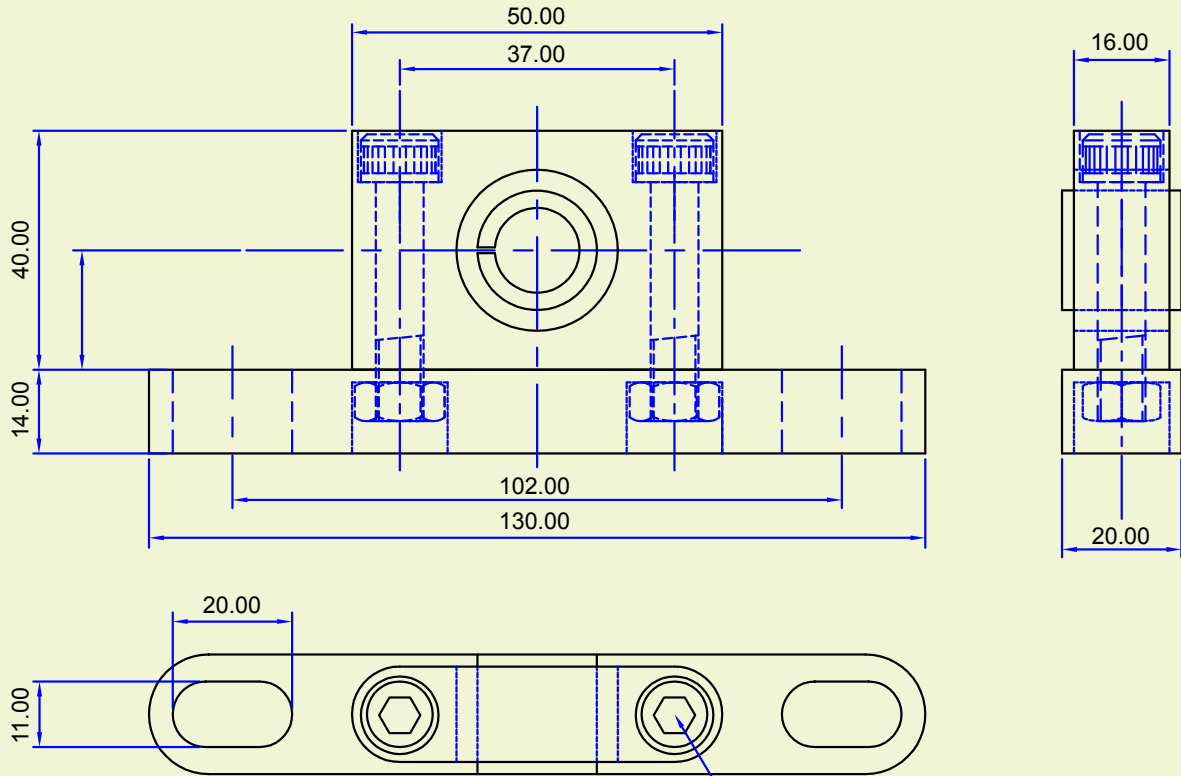

2 Off Socket Head Cap Screws M8 x 40LG
2 Off M8 Full Nuts

D) Heavy Duty Mounting Clamp

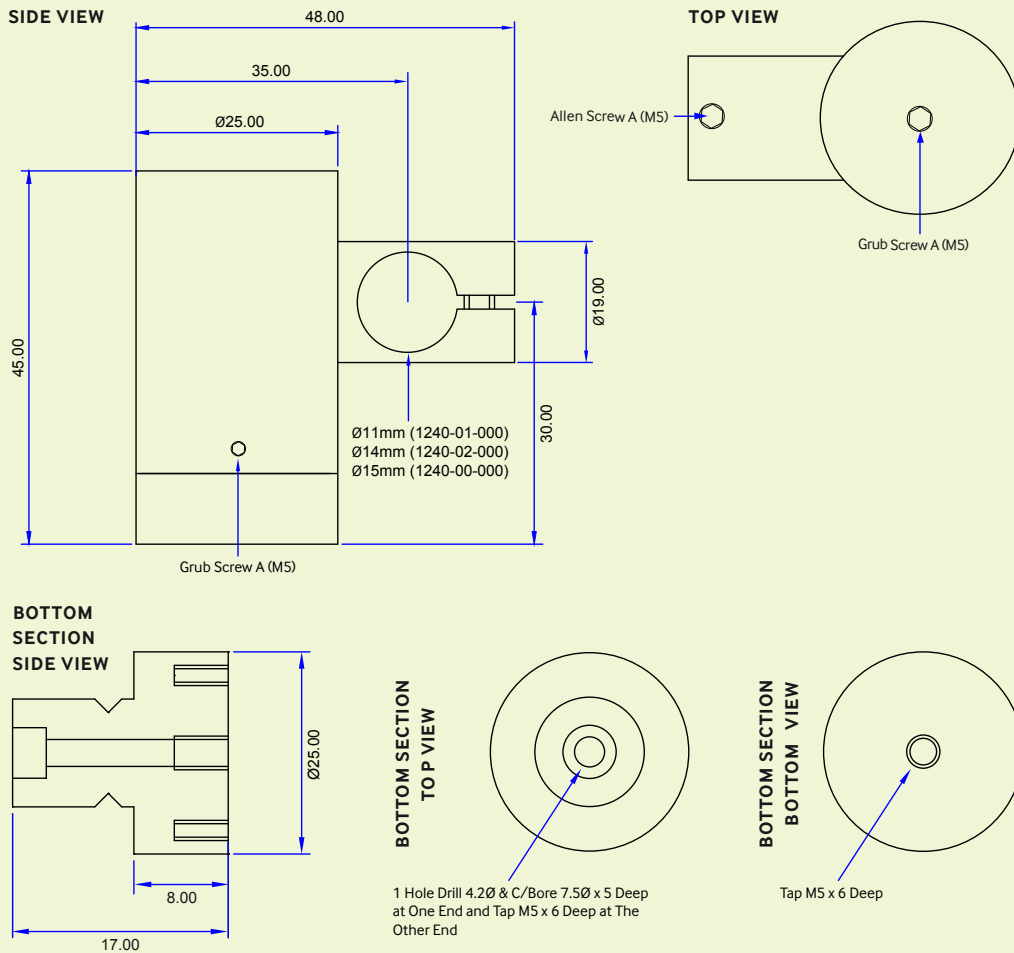

E) Magnetic Base

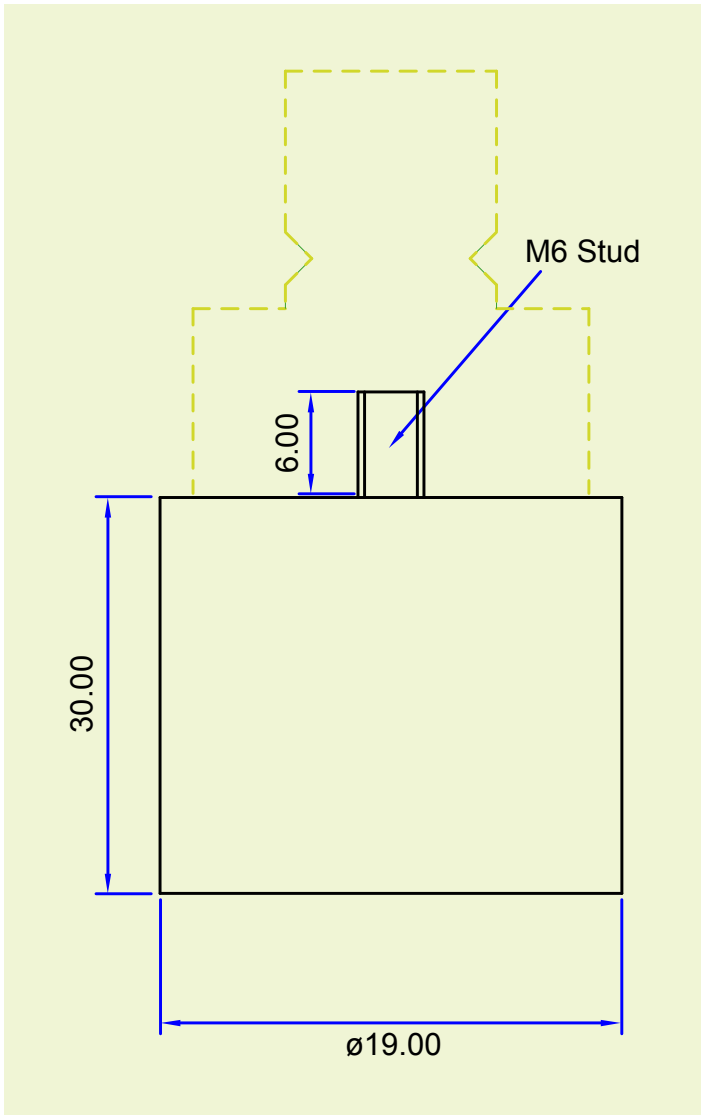

F) Swivel Mounting Clamp

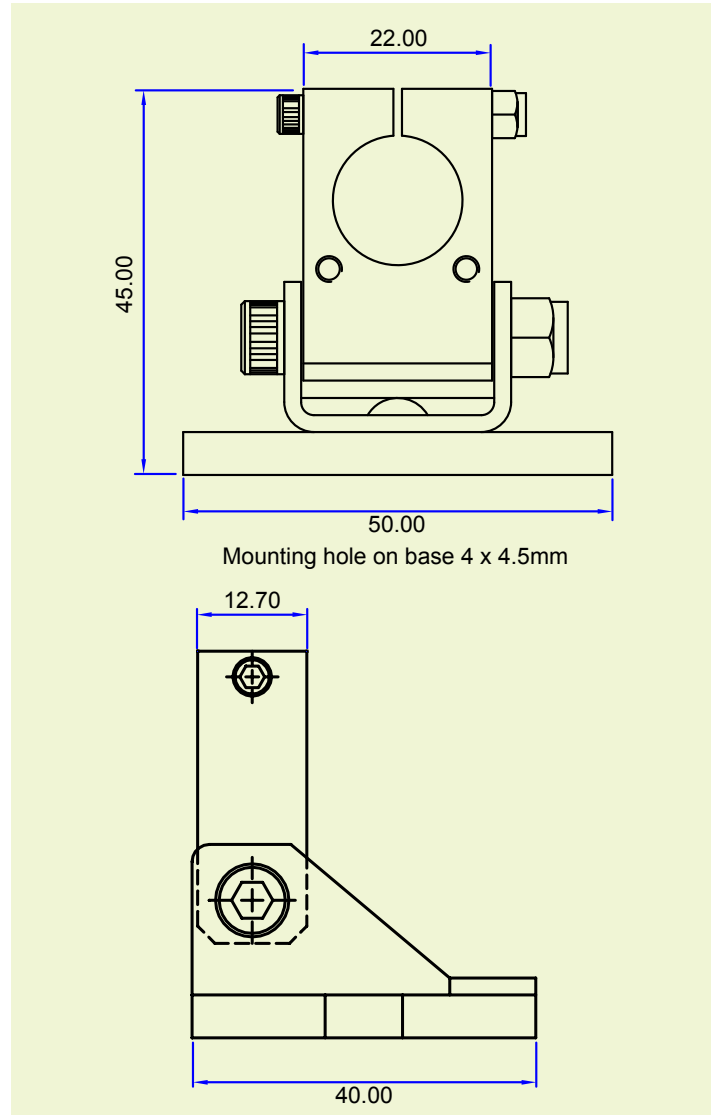

Drawings not to scale



9090-02-169 Rev 1 16/02/2021



T: +44 (0)1495 212213
F: +44 (0)1495 214004
E: sales@globalasertech.com
www.globalasertech.com

Global Laser Ltd
Units 9-10
Roseheyworth Business Park
Abertillery, Gwent NP13 1SP UK