

CARRIER VIEW

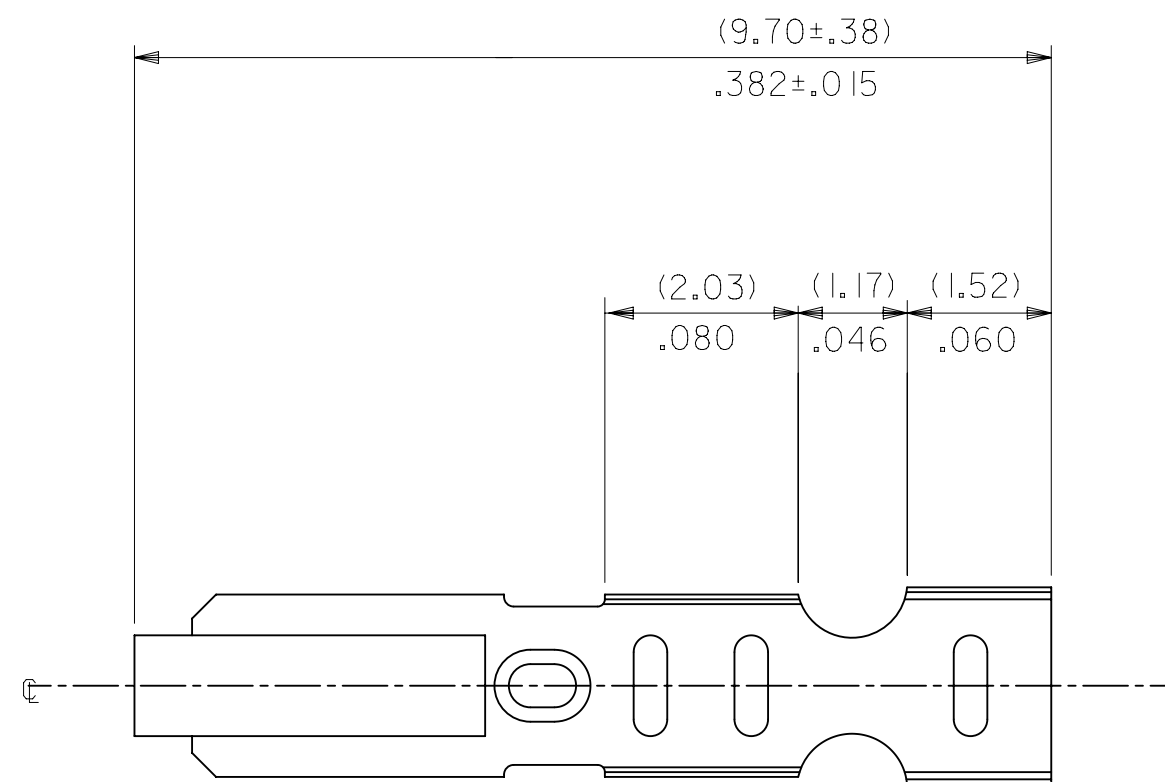
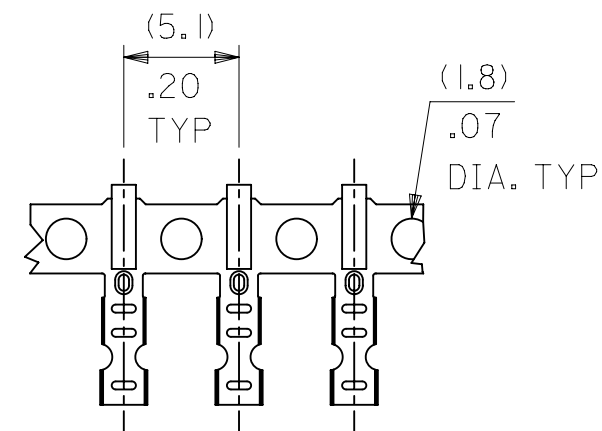

NOTES:

- MATERIAL:  
(0.20)/.008 THICK BRASS
- FINISH:  
122 - OVERALL TIN: (0.00381)/.000150 MIN. TIN OVER  
(0.00076)/.000030 MIN NICKEL  
154 - OVERALL TIN: (0.00254)/.000100 MIN. TIN OVER  
(0.00127)/.000050 MIN NICKEL  
P909 - OVERALL HOT TIN DIP: (0.00254)/.000100 MIN.  
550 - SELECT GOLD: (0.00038)/.000015 MIN.  
OVERALL GOLD FLASH: (0.00005)/.000002 MIN.  
OVERALL NICKEL UNDERPLATE: (0.00076)/.000030 MIN.  
555- SELECT GOLD (0.00038)/.000015 MIN.  
OVERALL NICKEL UNDERPLATE: (0.00076)/.000030  
558 - SELECT GOLD: (0.00076)/.000030 MIN.  
OVERALL GOLD FLASH: (0.00005)/.000002 MIN.  
OVERALL NICKEL UNDERPLATE: (0.00127)/.000050 MIN.
- PRODUCT SPEC: PS-10-07
- PACKAGING SPECIFICATION: LOOSE TERMINALS: PER PK-2759-001  
CHAIN FORM TERMINALS: PER PK-2759-002
- CRIMP IS FOR 22-30 GA WIRE WITH (1.57)/.062 DIA INSULATION MAX.
- INSERTION FORCE OF TERMINAL INTO (2.54)/.100 CENTERLINE CONNECTOR IS 2.5 LBS. MAX
- TERMINAL RETENTION IN HOUSING IS 26.7N / 6LBS MIN. WHEN PULLED AT THE RATE OF (25.4MM) / 1 INCH PER MINUTE.
- DIMENSIONS GIVEN ACROSS CENTERLINES ARE SYMMETRICAL ABOUT THOSE CENTERLINES WITHIN HALF THE TOTAL TOLERANCE.
- THIS PART CONFORMS TO CLASS B REQUIREMENTS OF COSMETIC SPECIFICATION PS-45499-002.

SELECT GOLD LOCATION

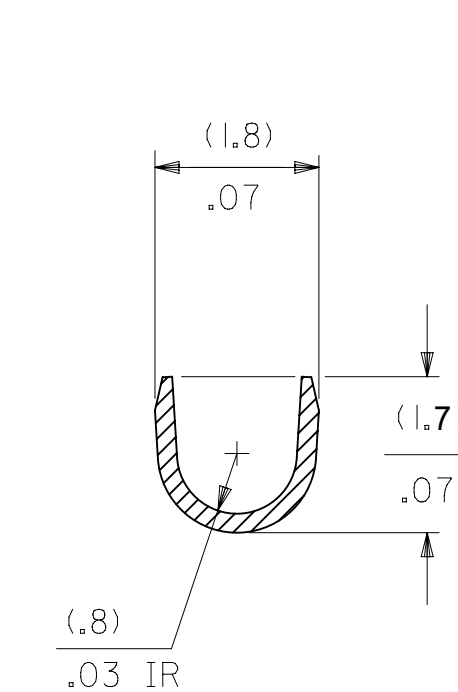
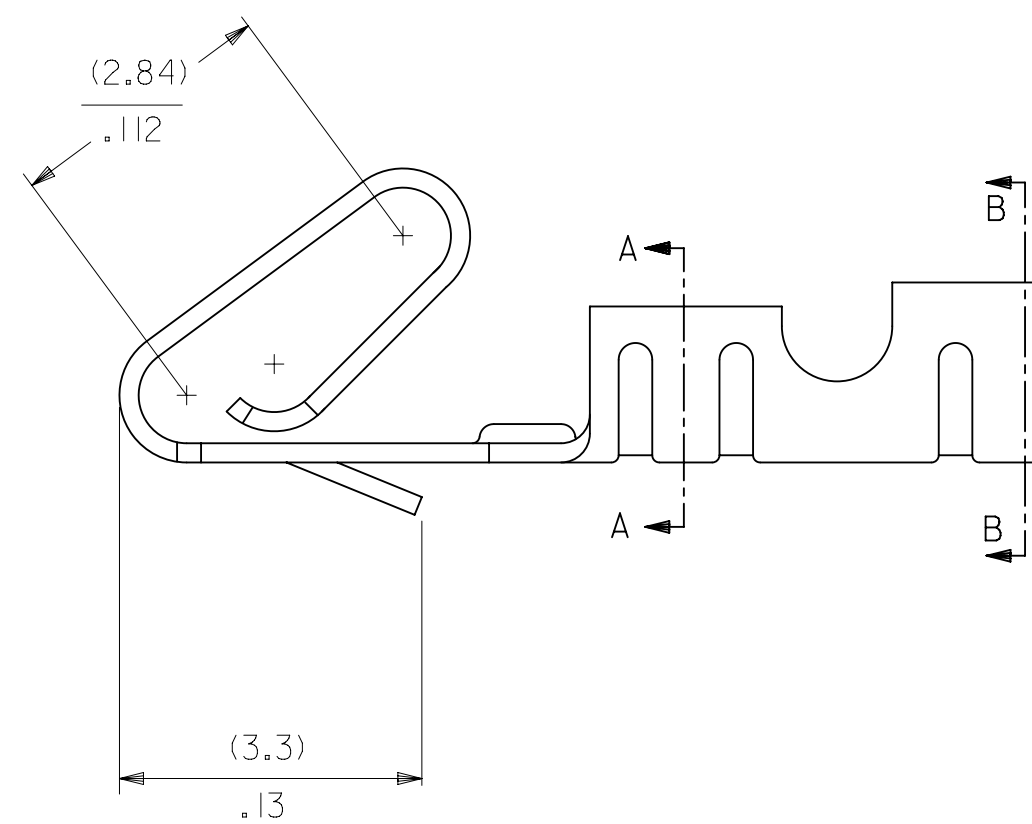
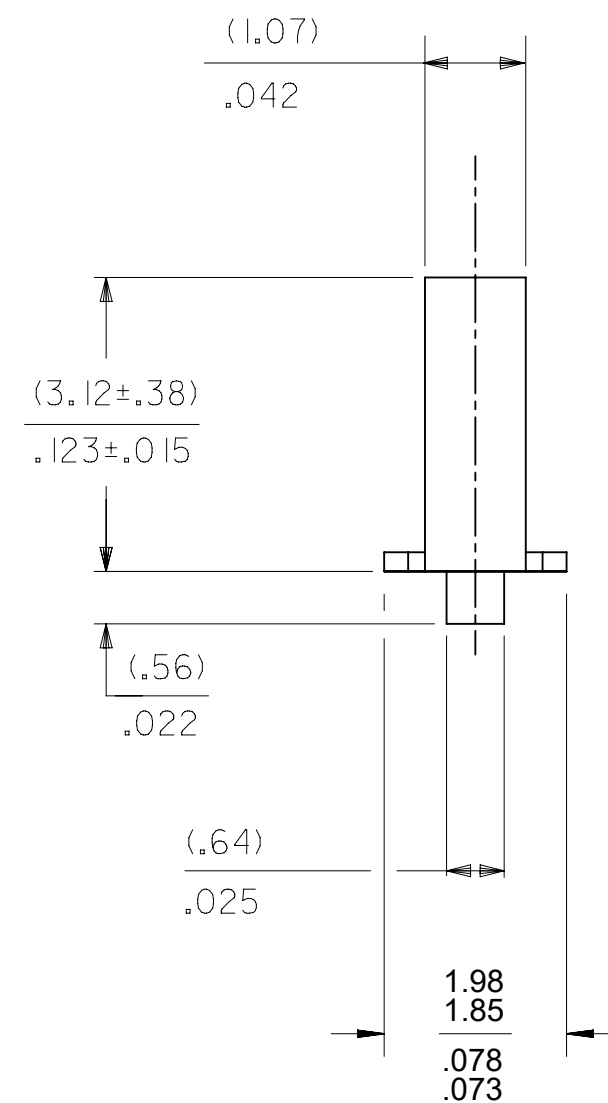
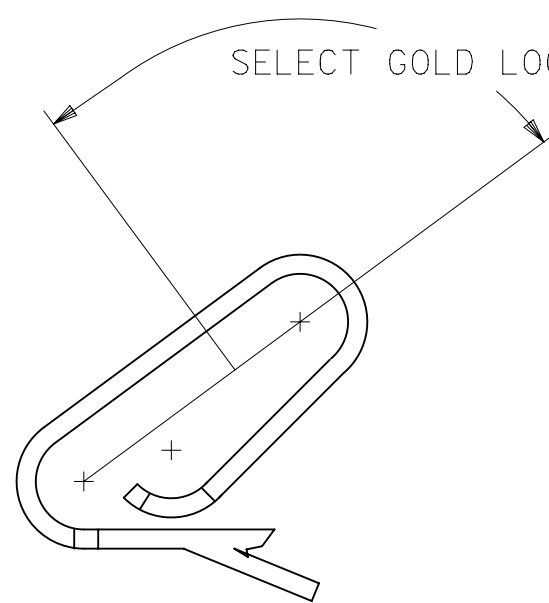

SECTION A-A  
BACKGROUND OMITTED

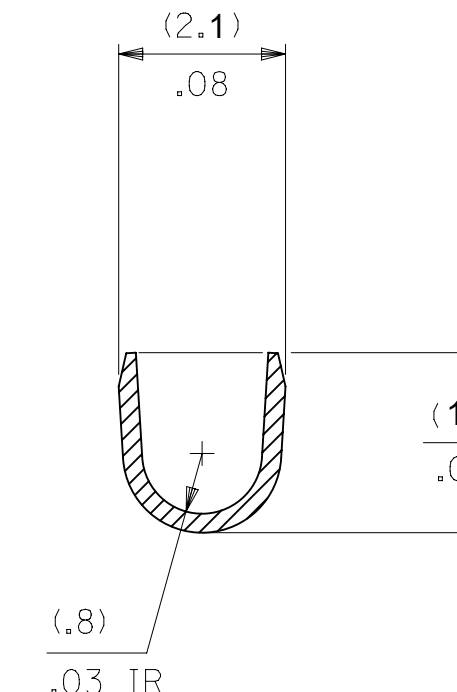

SECTION B-B  
BACKGROUND OMITTED

CRIMP DETAIL

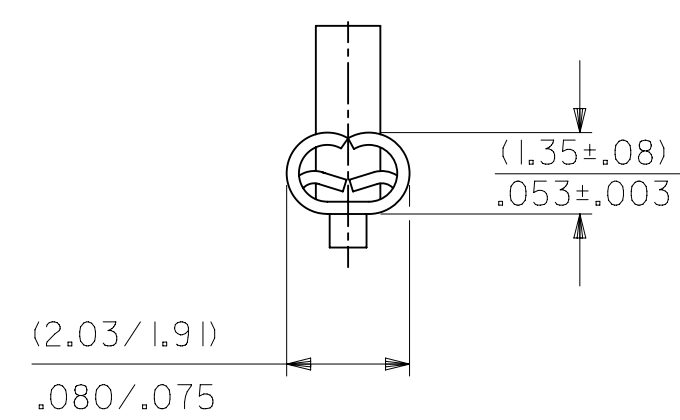

CRIMPED TERMINAL 2759-(P909)C IS USED WITHOUT WIRE AND IS INSERTED INTO HOUSING TO PROVIDE TENSION WHEN ASSEMBLED TO HEADERS DURING SHIPMENT.

2759-(\*\*\*)\*

- FORM
- L=LOOSE
- C=LOOSE CRIMPED
- A=CHAIN, PER WINDING DETAIL "A"
- B=CHAIN, PER WINDING DETAIL "B"

PLATING

SEE NOTE 2

THIS DRAWING CONTAINS INFORMATION THAT IS PROPRIETARY TO MOLEX ELECTRONIC TECHNOLOGIES, LLC AND SHOULD NOT BE USED WITHOUT WRITTEN PERMISSION

DIMENSION UNITS <b>MM/IN</b>	SCALE <b>1:1</b>	CURRENT REV DESC: OBSOLETE PART NUMBER AS PER PCN#509451	<b>molex</b>			
GENERAL TOLERANCES (UNLESS SPECIFIED)		EC NO: 686785				
4 PLACES ±	±	DRWN: SUGEEB	PRODUCT CUSTOMER DRAWING			
3 PLACES ±	± 0.01	CHK'D: GGA	DOCUMENT NUMBER	DOC TYPE	DOC PART	REVISION
2 PLACES ±	0.25 ± 0.014	APPR: GGA	<b>SD-2759</b>	PSD	001	AW3
1 PLACE ±	0.36 ±	INITIAL REVISION:	MATERIAL NUMBER	CUSTOMER	SHEET NUMBER	
0 PLACES ±	±	DRWN: SAMIEC	SEE TABLE	GENERAL MARKET	1 OF 2	
ANGULAR TOL ±	0.5 °	APPR: FSMITH				
DRAFT WHERE APPLICABLE MUST REMAIN WITHIN DIMENSIONS	THIRD ANGLE PROJECTION	DRAWING <b>D-SIZE</b>	SERIES <b>2759</b>			

