



ST485EB ST485EC - ST485EX

±15 kV ESD protected, low power
RS-485/RS-422 transceiver

Features

- Low quiescent current: 300 μ A
- Designed for RS-485 interface application
- - 7 V to 12 V common mode input voltage range
- Driver maintains high impedance in 3-state or with the power OFF
- 70 mV typical input hysteresis
- 30 ns propagation delay, 5 ns skew
- Operates from a single 5 V supply
- Current limiting and thermal shutdown for driver overload protection
- ESD protection:
 - ± 15 kV (HBM)
 - ± 8 kV (IEC-1000-4-2 contact discharge)
- Allows up to 256 transceivers on the bus

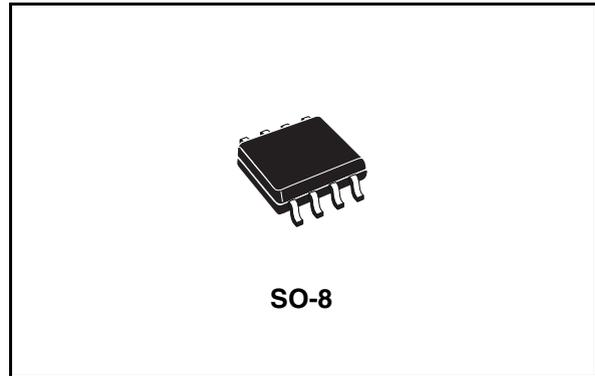

Driver is short-circuit current limited and is protected against excessive power dissipation by thermal shutdown circuitry that place the driver outputs into a high-impedance state.

The ST485E is designed for bi-directional data communications on multipoint bus transmission lines (half-duplex applications).

Description

The ST485E is a low power transceiver for RS-485 and RS-422 communication. Each driver output and receiver input is protected against ± 15 kV electrostatic discharge (HBM) (ESD) shocks, without latch-up. These parts contain one driver and one receiver in half duplex configuration.

This transceiver draws 300 μ A (typ.) of supply current when unloaded or fully loaded with disabled drivers.

It operates from a single 5 V supply.

Table 1. Device summary

| Order codes | Temperature range | Package | Packaging |
|-------------|-------------------|----------------------|--------------------------------------|
| ST485EBD | - 40 to 85 °C | SO-8 (tube) | 100 parts per tube / 20 tube per box |
| ST485ECCR | 0 to 70 °C | SO-8 (tape and reel) | 2500 parts per reel |
| ST485EBDR | - 40 to 85 °C | SO-8 (tape and reel) | 2500 parts per reel |
| ST485EXDR | - 55 to 125 °C | SO-8 (tape and reel) | 2500 parts per reel |

Contents

| | | |
|---|--|----|
| 1 | Pin configuration | 3 |
| 2 | Truth tables | 4 |
| 3 | Maximum ratings | 5 |
| 4 | Electrical characteristics | 6 |
| 5 | Test circuit and typical characteristics | 9 |
| 6 | Package mechanical data | 14 |
| 7 | Revision history | 17 |

1 Pin configuration

Figure 1. Pin connections (top view)

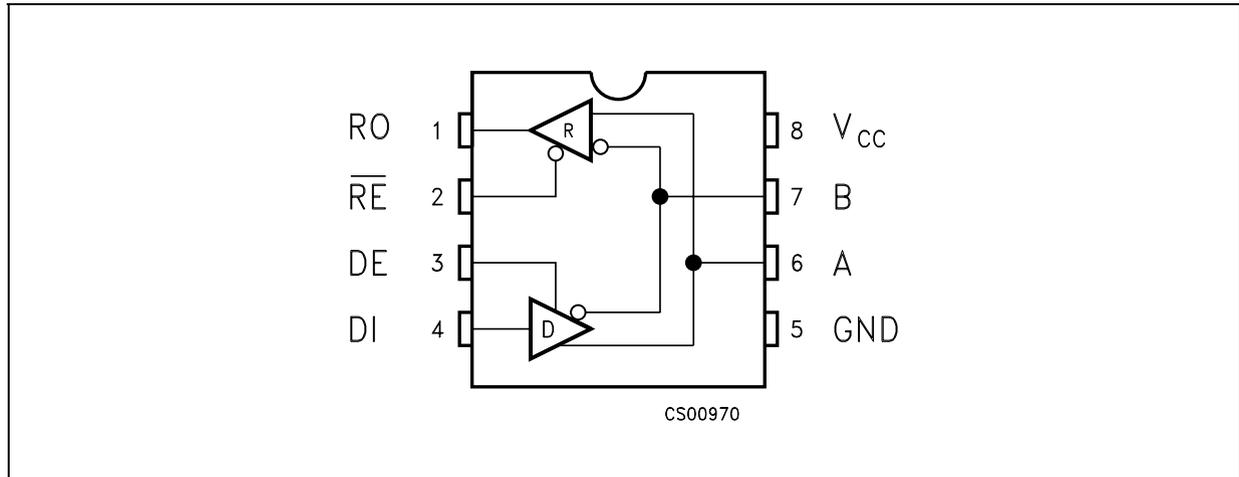

Table 2. Pin description

| Pin n° | Symbol | Name and function |
|--------|-----------------|--|
| 1 | RO | Receiver output |
| 2 | \overline{RE} | Receiver output enable |
| 3 | DE | Driver output enable |
| 4 | DI | Driver input |
| 5 | GND | Ground |
| 6 | A | Non-inverting receiver input and non-inverting driver output |
| 7 | B | Inverting receiver input and inverting driver output |
| 8 | V_{CC} | Supply voltage |

2 Truth tables

Table 3. Truth table (driver)

| Inputs | | | Outputs | |
|--------|----|----|---------|---|
| RE | DE | DI | B | A |
| X | H | H | L | H |
| X | H | L | H | L |
| X | L | X | Z | Z |

Note: X = Don't care; Z = High impedance

Table 4. Truth table (receiver)

| Inputs | | | Outputs |
|--------|----|--------------|---------|
| RE | DE | A-B | RO |
| L | L | $\geq +0.2V$ | H |
| L | L | $\leq -0.2V$ | L |
| L | L | Inputs open | H |
| H | L | X | Z |

Note: X = Don't care; Z = High impedance

3 Maximum ratings

Table 5. Absolute maximum ratings

| Symbol | Parameter | Value | Unit |
|----------|---|----------------------------|------|
| V_{CC} | Supply voltage | 7 | V |
| V_I | Control input voltage (\overline{RE} , DE) | -0.5 to ($V_{CC} + 0.5$) | V |
| V_{DI} | Driver input voltage (DI) | -0.5 to ($V_{CC} + 0.5$) | V |
| V_{DO} | Driver output voltage (A, B) | ± 14 | V |
| V_{RI} | Receiver input voltage (A, B) | ± 14 | V |
| V_{RO} | Receiver output voltage (RO) | -0.5 to ($V_{CC} + 0.5$) | V |

Note: Absolute maximum ratings are those values beyond which damage to the device may occur. Functional operation under these is not implied.

4 Electrical characteristics

Table 6. ESD performance: transmitter outputs, receiver inputs

| Symbol | Parameter | Test conditions | Min. | Typ. | Max. | Unit |
|--------|------------------------|------------------|------|------|------|------|
| ESD | ESD protection voltage | Human body model | ±15 | | | kV |
| ESD | ESD protection voltage | IEC-1000-4-2 | ±8 | | | kV |

$V_{CC} = 5\text{ V} \pm 5\%$, $T_A = T_{MIN}$ to T_{MAX} , unless otherwise specified. Typical values are referred to $T_A = 25\text{ °C}$

Table 7. DC electrical characteristics

| Symbol | Parameter | Test conditions ⁽¹⁾ | Min. | Typ. | Max. | Unit |
|-----------------|---|--|------|------------|------------|----------|
| V_{OD1} | Differential driver output (no load) | | | | 5 | V |
| V_{OD2} | Differential driver output (with load) | $R_L = 27\ \Omega$ (RS-485) (<i>Figure 2</i>) $R_L = 50\ \Omega$ (RS-422) (<i>Figure 2</i>) | 1.5 | | 5 5 | V V |
| ΔV_{OD} | Change in magnitude of driver differential output voltage for complementary output states | $R_L = 27\ \Omega$ or $50\ \Omega$ (<i>Figure 2</i>) | | | 0.2 | V |
| V_{OC} | Driver common-mode output voltage | $R_L = 27\ \Omega$ or $50\ \Omega$ (<i>Figure 2</i>) | | | 3 | V |
| ΔV_{OC} | Change in magnitude of driver common-mode output voltage for complementary output states | $R_L = 27\ \Omega$ or $50\ \Omega$ (<i>Figure 2</i>) | | | 0.2 | V |
| V_{IH} | Input high voltage | \overline{RE} , DE, DI | 2.0 | | | V |
| V_{IL} | Input low voltage | \overline{RE} , DE, DI | | | 0.8 | V |
| I_{IN1} | Input current | \overline{RE} , DE, DI | | | ±2 | μA |
| I_{IN2} | Input current (A, B) | $V_{CM} = 0\text{ V}$ or 5.25 V , $V_{DE} = 0\text{ V}$ $V_{IN} = 12\text{ V}$ $V_{IN} = -7\text{ V}$ | | | 1 -0.8 | mA mA |
| V_{TH} | Receiver differential threshold voltage | $V_{CM} = -7$ to 12 V | -0.2 | | 0.2 | V |
| ΔV_{TH} | Receiver input hysteresis | $V_{CM} = 0\text{ V}$ | | 70 | | mV |
| V_{OH} | Receiver output high voltage | $I_O = -4\text{ mA}$, $V_{ID} = 200\text{ mV}$ | 3.5 | | | V |
| V_{OL} | Receiver output low voltage | $I_O = 4\text{ mA}$, $V_{ID} = -200\text{ mV}$ | | | 0.4 | V |
| I_{OZR} | 3-State (high impedance) output current at receiver | $V_O = 0.4$ to 2.4 V | | | ±1 | μA |
| R_{IN} | Receiver input resistance | $V_{CM} = -7$ to 12 V | 96 | | | kΩ |
| I_{CC} | No load supply current ⁽²⁾ | $V_{RE} = 0\text{V}$ or V_{CC} $V_{DE} = V_{CC}$ $V_{DE} = 0\text{ V}$ | | 400 300 | 900 500 | μA μA |

Table 7. DC electrical characteristics (continued)

| Symbol | Parameter | Test conditions ⁽¹⁾ | Min. | Typ. | Max. | Unit |
|-------------------|--|--|------|------|------|------|
| I _{OSD1} | Driver short-circuit current, V _O =High | V _O = -7 to 12 V ⁽³⁾ | 35 | | 250 | mA |
| I _{OSD2} | Driver short-circuit current, V _O =Low | V _O = -7 to 12 V ⁽³⁾ | 35 | | 250 | mA |
| I _{OSR} | Receiver short-circuit current | V _O = 0 V to V _{CC} | 7 | | 95 | mA |

1. All currents into device pins are positive; all out of device pins are negative; all voltages are referenced to device ground unless specified.
2. Supply current specification is valid for loaded transmitters when V_{DE} = 0 V
3. Applies to peak current. See typical Operating Characteristics.

V_{CC} = 5 V ± 5 %, T_A = T_{MIN} to T_{MAX}, unless otherwise specified. Typical values are referred to T_A = 25 °C

Table 8. Driver switching characteristics

| Symbol | Parameter | Test conditions ⁽¹⁾ | Min. | Typ. | Max. | Unit |
|--------------------------------------|-----------------------------------|--|------|------|------|------|
| t _{PLH} t _{PHL} | Propagation delay input to output | R _{DIFF} = 54 Ω, C _{L1} = C _{L2} = 100 pF (See Figure 4 and Figure 6) | | 25 | 45 | ns |
| t _{SK} | Output skew to output | R _{DIFF} = 54 Ω, C _{L1} = C _{L2} = 100 pF (See Figure 4 and Figure 6) | | 2 | 5 | ns |
| t _{TLH} t _{THL} | Rise or fall time | R _{DIFF} = 54 Ω, C _{L1} = C _{L2} = 100 pF (See Figure 4 and Figure 6) | | 15 | 40 | ns |
| t _{PZH} | Output enable time | C _L = 100 pF, S2 = Closed (See Figure 5 and Figure 7) | | 35 | 50 | ns |
| t _{PZL} | Output enable time | C _L = 100 pF, S1 = Closed (See Figure 5 and Figure 7) | | 25 | 40 | ns |
| t _{PLZ} | Output disable time | C _L = 15 pF, S1 = Closed (See Figure 5 and Figure 7) | | 25 | 40 | ns |
| t _{PHZ} | Output disable time | C _L = 15 pF, S2 = Closed (See Figure 5 and Figure 7) | | 35 | 50 | ns |

1. All currents into device pins are positive; all out of device pins are negative; all voltages are referenced to device ground unless specified.

$V_{CC} = 5\text{ V} \pm 5\%$, $T_A = T_{MIN}$ to T_{MAX} , unless otherwise specified. Typical values are referred to $T_A = 25\text{ }^\circ\text{C}$

Table 9. Receiver switching characteristics

| Symbol | Parameter | Test conditions ⁽¹⁾ | Min. | Typ. | Max. | Unit |
|------------------------|-----------------------------------|---|------|------|------|------|
| t_{PLH} t_{PHL} | Propagation delay input to output | $R_{DIFF} = 54\ \Omega$, $C_{L1} = C_{L2} = 100\text{ pF}$ (See Figure 4 and Figure 8) | | 110 | 130 | ns |
| t_{SKD} | Differential receiver skew | $R_{DIFF} = 54\ \Omega$, $C_{L1} = C_{L2} = 100\text{ pF}$ (See Figure 4 and Figure 8) | | 5 | 10 | ns |
| t_{PZH} | Output enable time | $C_{RL} = 15\text{ pF}$, S1 = Closed (See Figure 2 and Figure 9) | | 11 | 35 | ns |
| t_{PZL} | Output enable time | $C_{RL} = 15\text{ pF}$, S2 = Closed (See Figure 2 and Figure 9) | | 13 | 35 | ns |
| t_{PLZ} | Output disable time | $C_{RL} = 15\text{ pF}$, S1 = Closed (See Figure 2 and Figure 9) | | 13 | 35 | ns |
| t_{PHZ} | Output disable time | $C_{RL} = 15\text{ pF}$, S2 = Closed (See Figure 2 and Figure 9) | | 11 | 35 | ns |
| f_{MAX} | Maximum data rate | | 5 | | | Mbps |

1. All currents into device pins are positive; all out of device pins are negative; all voltages are referenced to device ground unless specified

5 Test circuit and typical characteristics

Figure 2. Driver DC test load

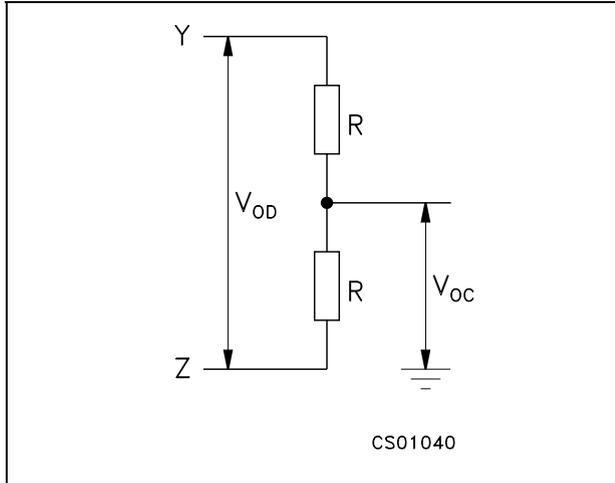

Figure 3. Receiver timing test load

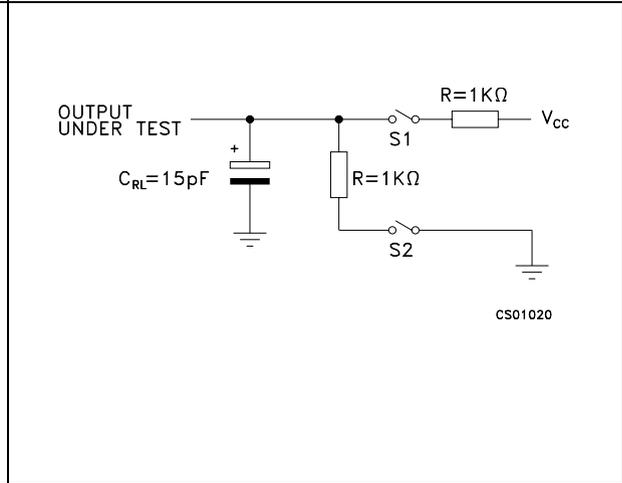

Figure 4. Drive/receiver timing test circuit

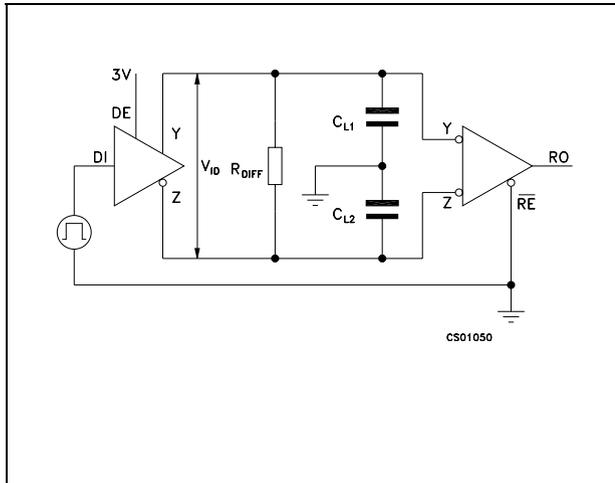

Figure 5. Driver timing test load

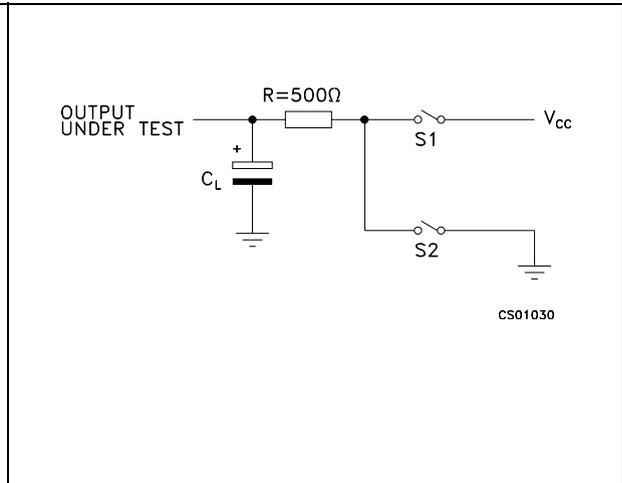

Figure 6. Driver propagation delay

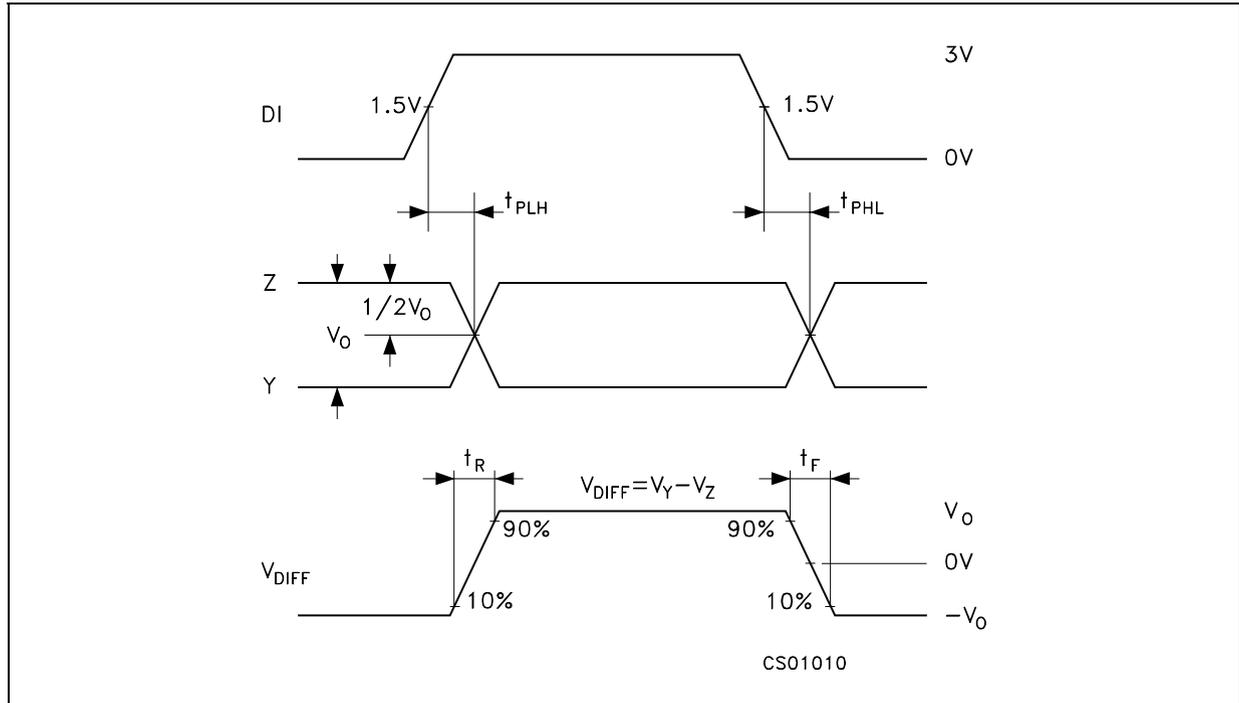

Figure 7. Driver enable and disable time

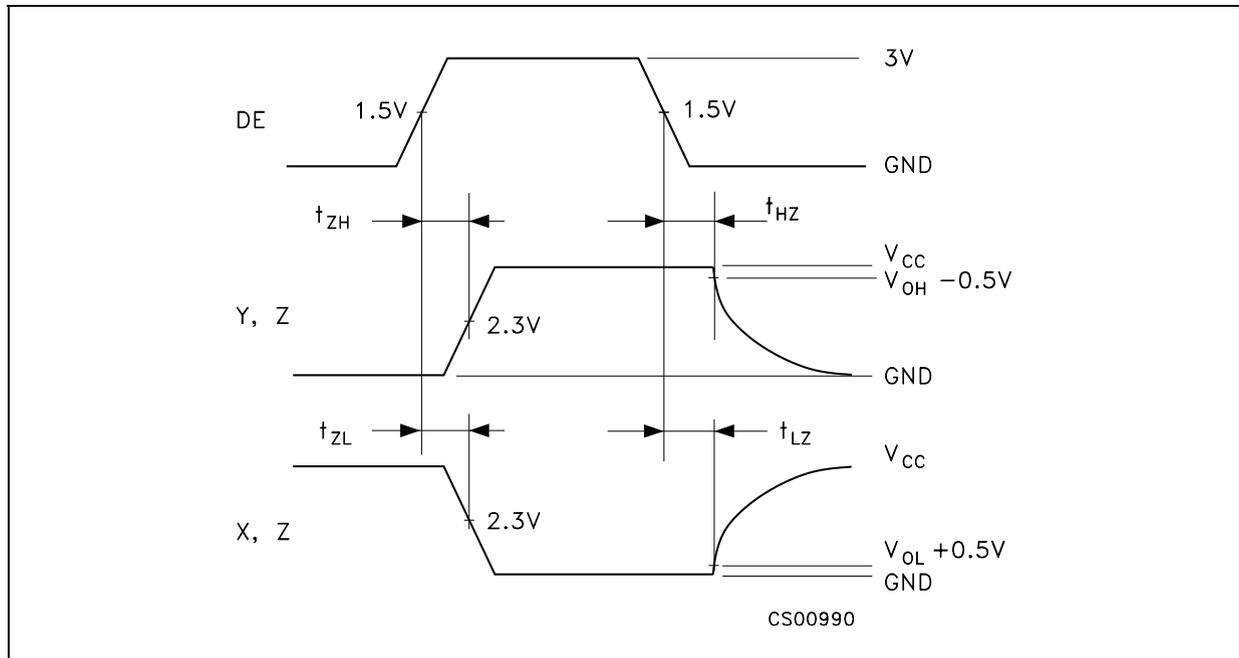

Figure 8. Receiver propagation delay

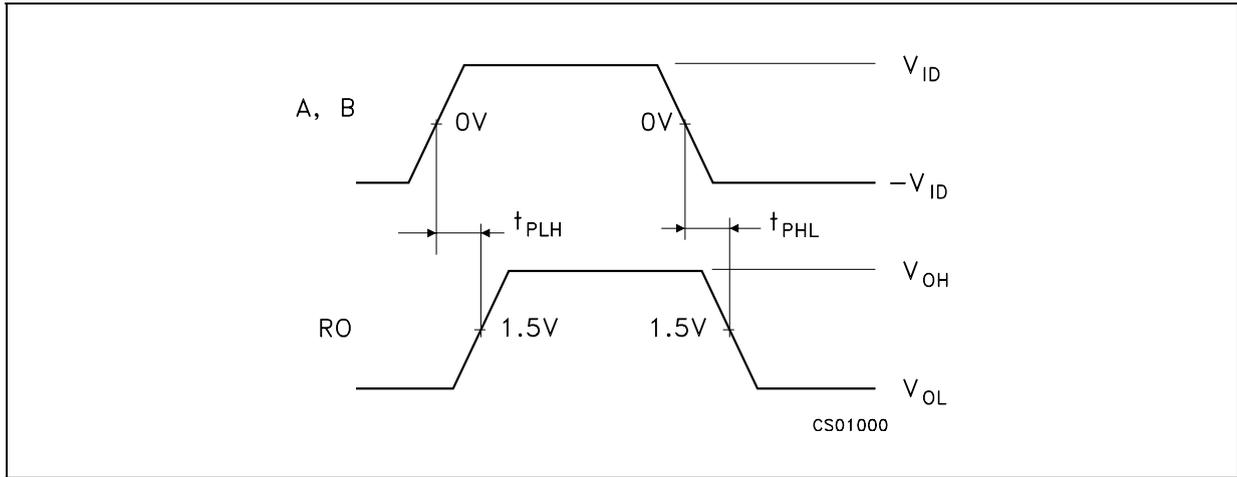

Figure 9. Receiver enable and disable time

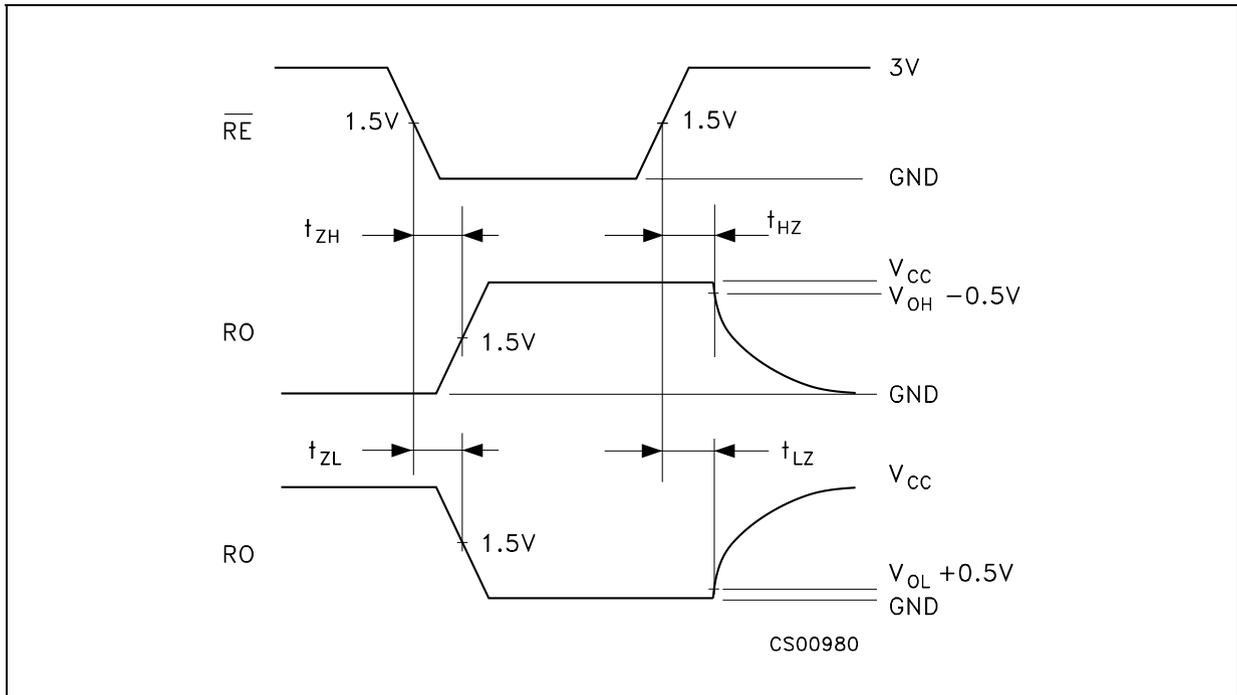

Figure 10. Receiver output current vs. output low voltage

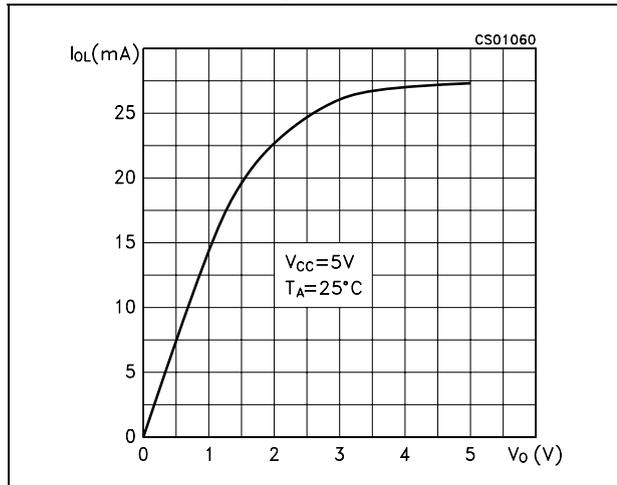

Figure 11. Receiver output current vs. output high voltage

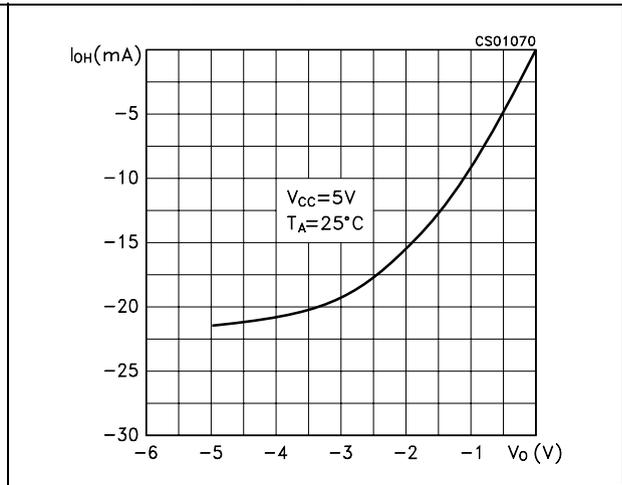

Figure 12. Driver output current vs. output low voltage

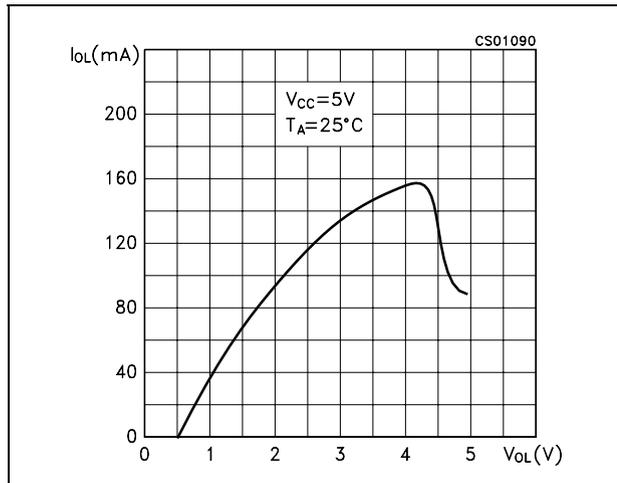

Figure 13. Driver output current vs. output high voltage

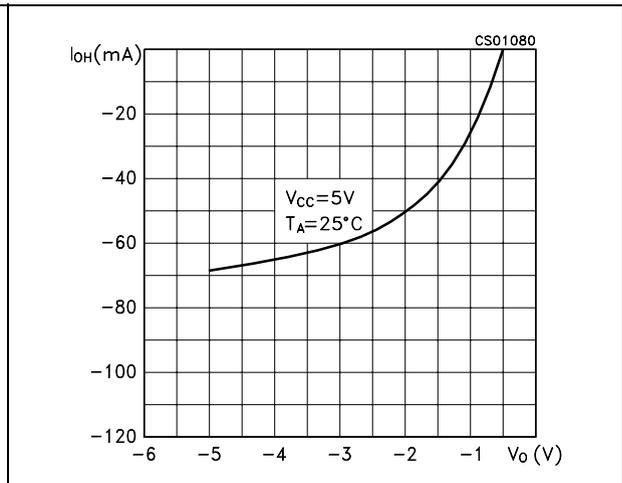

Figure 14. Supply current vs. temperature

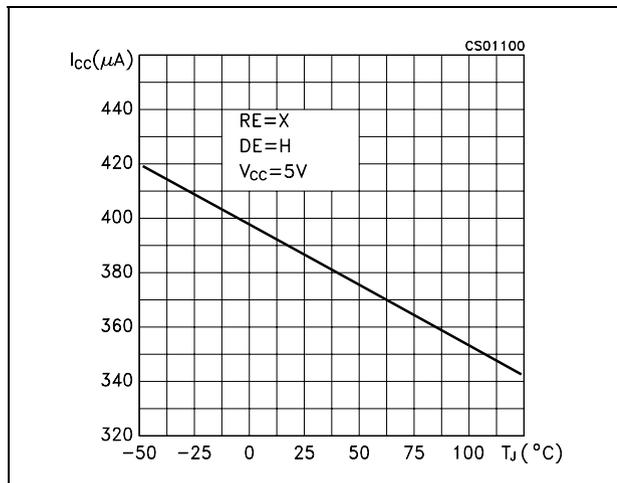

Figure 15. Receiver high level output voltage vs. temperature

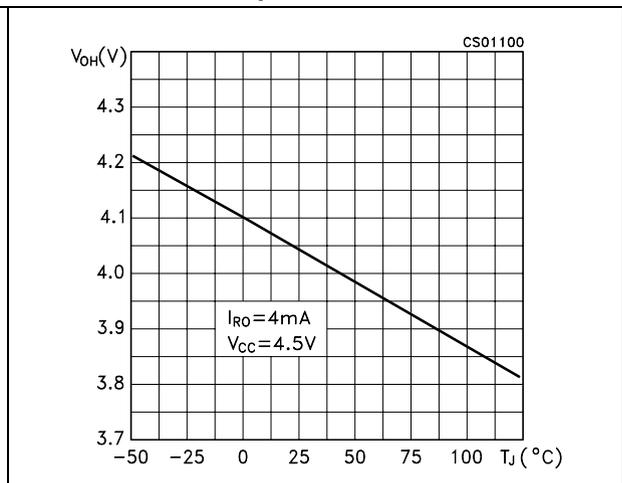

Figure 16. Receiver low level output voltage vs. temperature

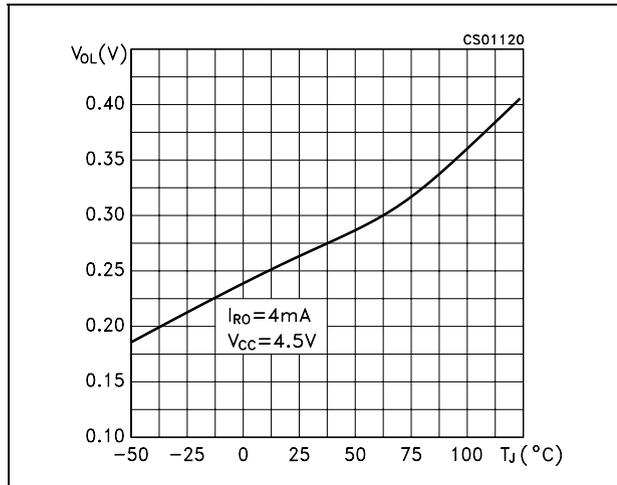
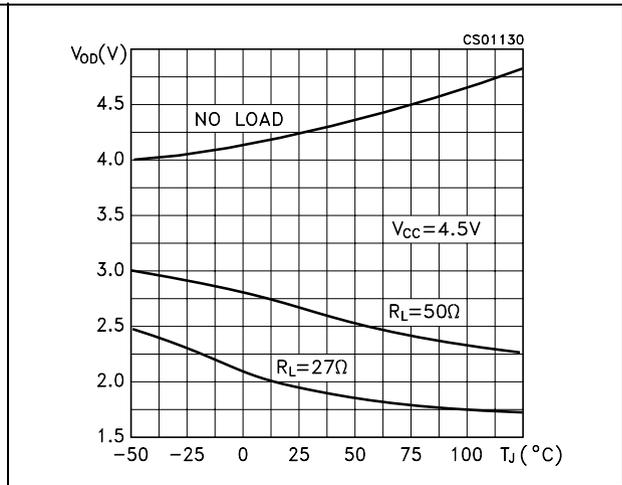

Figure 17. Differential driver output voltage vs. temperature



6 Package mechanical data

In order to meet environmental requirements, ST offers these devices in different grades of ECOPACK® packages, depending on their level of environmental compliance. ECOPACK® specifications, grade definitions and product status are available at: www.st.com. ECOPACK is an ST trademark.

SO-8 mechanical data

| Dim. | mm. | | | inch. | | |
|------|-----------|------|------|-------|-------|-------|
| | Min. | Typ. | Max. | Min. | Typ. | Max. |
| A | 1.35 | | 1.75 | 0.053 | | 0.069 |
| A1 | 0.10 | | 0.25 | 0.04 | | 0.010 |
| A2 | 1.10 | | 1.65 | 0.043 | | 0.065 |
| B | 0.33 | | 0.51 | 0.013 | | 0.020 |
| C | 0.19 | | 0.25 | 0.007 | | 0.010 |
| D | 4.80 | | 5.00 | 0.189 | | 0.197 |
| E | 3.80 | | 4.00 | 0.150 | | 0.157 |
| e | | 1.27 | | | 0.050 | |
| H | 5.80 | | 6.20 | 0.228 | | 0.244 |
| h | 0.25 | | 0.50 | 0.010 | | 0.020 |
| L | 0.40 | | 1.27 | 0.016 | | 0.050 |
| k | 8° (max.) | | | | | |
| ddd | | | 0.1 | | | 0.04 |

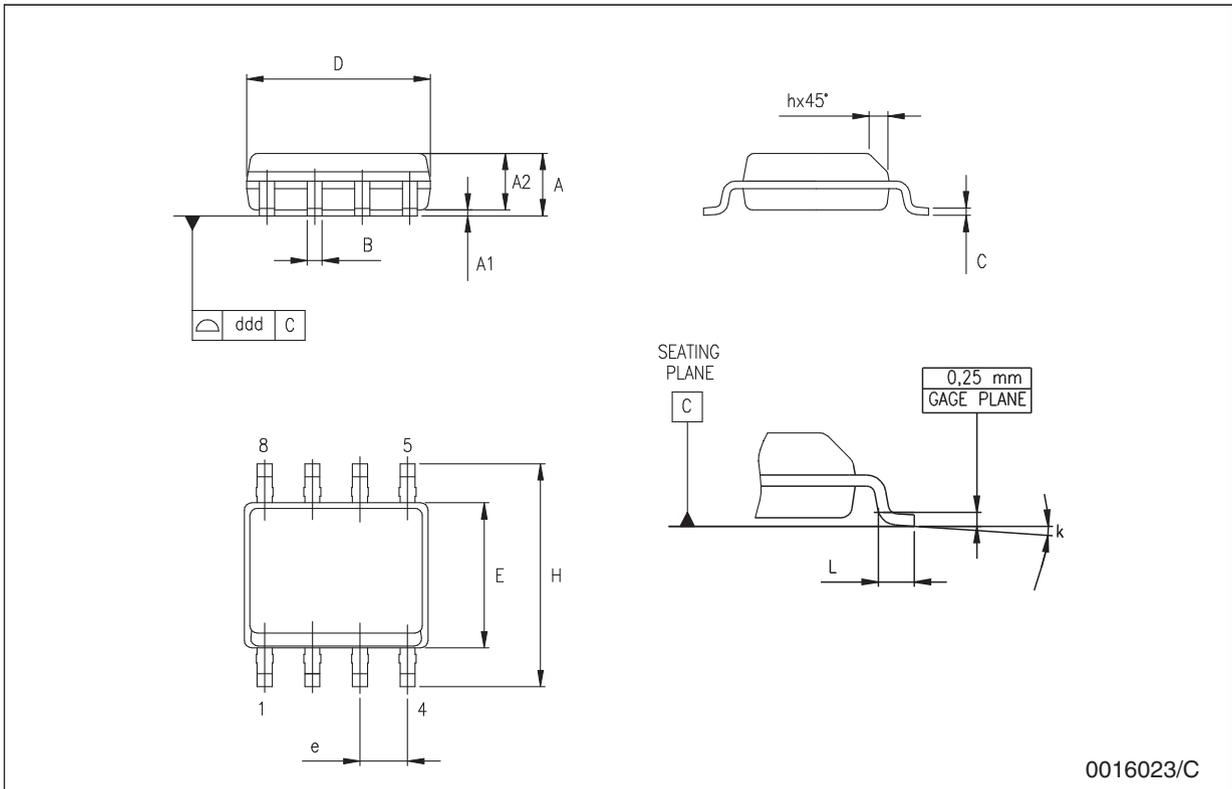

0016023/C

Tape & reel SO-8 mechanical data

| Dim. | mm. | | | inch. | | |
|------|------|------|------|-------|------|--------|
| | Min. | Typ. | Max. | Min. | Typ. | Max. |
| A | | | 330 | | | 12.992 |
| C | 12.8 | | 13.2 | 0.504 | | 0.519 |
| D | 20.2 | | | 0.795 | | |
| N | 60 | | | 2.362 | | |
| T | | | 22.4 | | | 0.882 |
| Ao | 8.1 | | 8.5 | 0.319 | | 0.335 |
| Bo | 5.5 | | 5.9 | 0.216 | | 0.232 |
| Ko | 2.1 | | 2.3 | 0.082 | | 0.090 |
| Po | 3.9 | | 4.1 | 0.153 | | 0.161 |
| P | 7.9 | | 8.1 | 0.311 | | 0.319 |

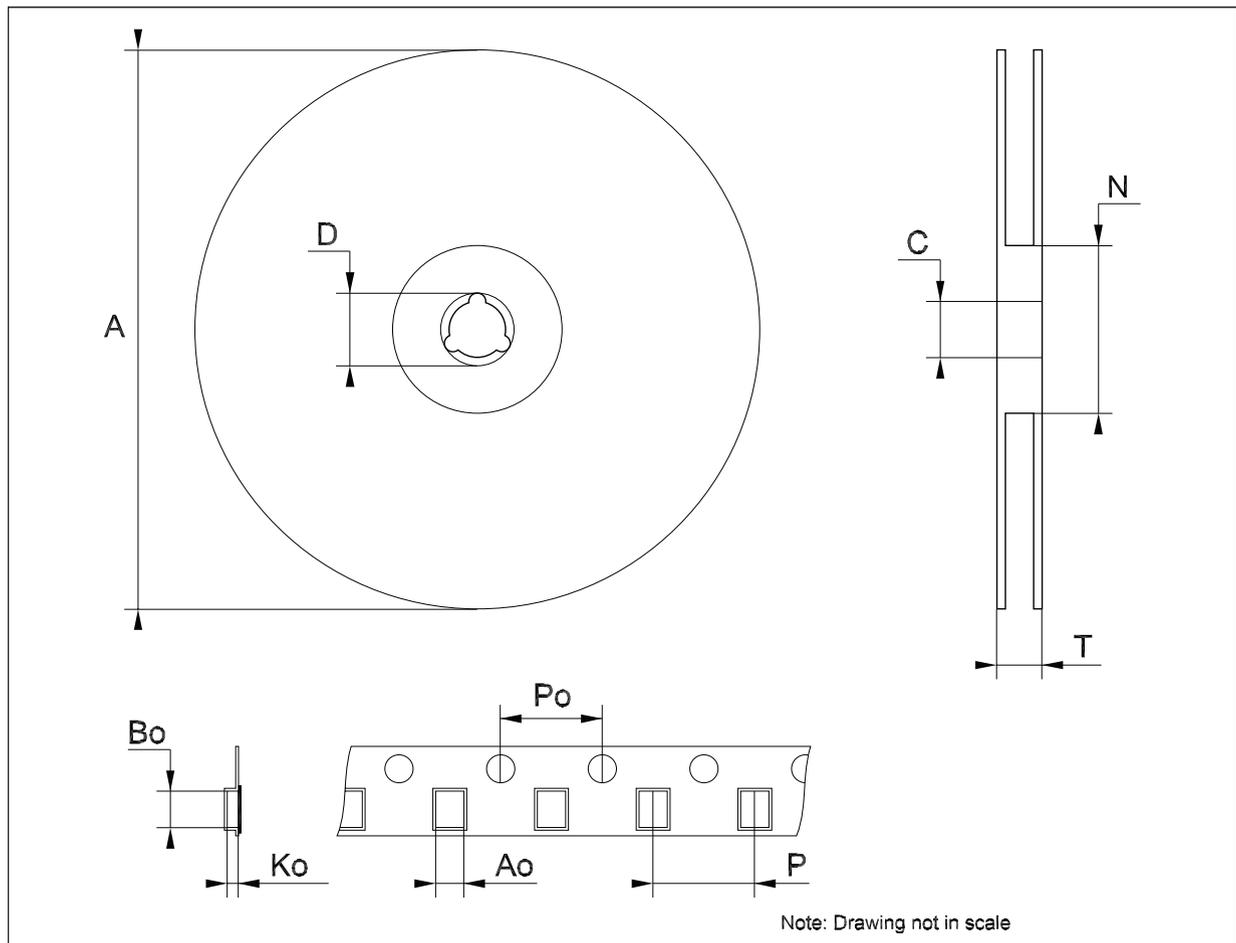

7 Revision history

Table 10. Document revision history

| Date | Revision | Changes |
|-------------|----------|---|
| 21-Mar-2006 | 9 | Order codes has been updated and new template. |
| 05-Jun-2006 | 10 | Change value row 10 on the features and R_{IN} in Table 7 . |
| 29-Jan-2007 | 11 | Typo mistake on page 1. |
| 29-Aug-2007 | 12 | Change value R_{IN} min. on Table 7 . |
| 07-Feb-2008 | 13 | Modified: Table 1 on page 1 . |
| 16-Feb-2009 | 14 | Modified: Note: on page 5 . |

Please Read Carefully:

Information in this document is provided solely in connection with ST products. STMicroelectronics NV and its subsidiaries ("ST") reserve the right to make changes, corrections, modifications or improvements, to this document, and the products and services described herein at any time, without notice.

All ST products are sold pursuant to ST's terms and conditions of sale.

Purchasers are solely responsible for the choice, selection and use of the ST products and services described herein, and ST assumes no liability whatsoever relating to the choice, selection or use of the ST products and services described herein.

No license, express or implied, by estoppel or otherwise, to any intellectual property rights is granted under this document. If any part of this document refers to any third party products or services it shall not be deemed a license grant by ST for the use of such third party products or services, or any intellectual property contained therein or considered as a warranty covering the use in any manner whatsoever of such third party products or services or any intellectual property contained therein.

UNLESS OTHERWISE SET FORTH IN ST'S TERMS AND CONDITIONS OF SALE ST DISCLAIMS ANY EXPRESS OR IMPLIED WARRANTY WITH RESPECT TO THE USE AND/OR SALE OF ST PRODUCTS INCLUDING WITHOUT LIMITATION IMPLIED WARRANTIES OF MERCHANTABILITY, FITNESS FOR A PARTICULAR PURPOSE (AND THEIR EQUIVALENTS UNDER THE LAWS OF ANY JURISDICTION), OR INFRINGEMENT OF ANY PATENT, COPYRIGHT OR OTHER INTELLECTUAL PROPERTY RIGHT.

UNLESS EXPRESSLY APPROVED IN WRITING BY AN AUTHORIZED ST REPRESENTATIVE, ST PRODUCTS ARE NOT RECOMMENDED, AUTHORIZED OR WARRANTED FOR USE IN MILITARY, AIR CRAFT, SPACE, LIFE SAVING, OR LIFE SUSTAINING APPLICATIONS, NOR IN PRODUCTS OR SYSTEMS WHERE FAILURE OR MALFUNCTION MAY RESULT IN PERSONAL INJURY, DEATH, OR SEVERE PROPERTY OR ENVIRONMENTAL DAMAGE. ST PRODUCTS WHICH ARE NOT SPECIFIED AS "AUTOMOTIVE GRADE" MAY ONLY BE USED IN AUTOMOTIVE APPLICATIONS AT USER'S OWN RISK.

Resale of ST products with provisions different from the statements and/or technical features set forth in this document shall immediately void any warranty granted by ST for the ST product or service described herein and shall not create or extend in any manner whatsoever, any liability of ST.

ST and the ST logo are trademarks or registered trademarks of ST in various countries.

Information in this document supersedes and replaces all information previously supplied.

The ST logo is a registered trademark of STMicroelectronics. All other names are the property of their respective owners.

© 2009 STMicroelectronics - All rights reserved

STMicroelectronics group of companies

Australia - Belgium - Brazil - Canada - China - Czech Republic - Finland - France - Germany - Hong Kong - India - Israel - Italy - Japan - Malaysia - Malta - Morocco - Singapore - Spain - Sweden - Switzerland - United Kingdom - United States of America

www.st.com

Mouser Electronics

Authorized Distributor

Click to View Pricing, Inventory, Delivery & Lifecycle Information:

[STMicroelectronics:](#)

[ST485ECDR](#) [ST485EBDR](#) [ST485EXDR](#)