

PRODUCT NO.

SEE TABLE

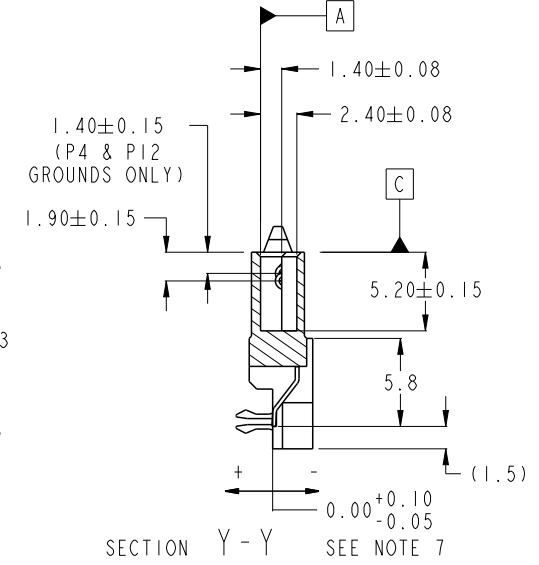
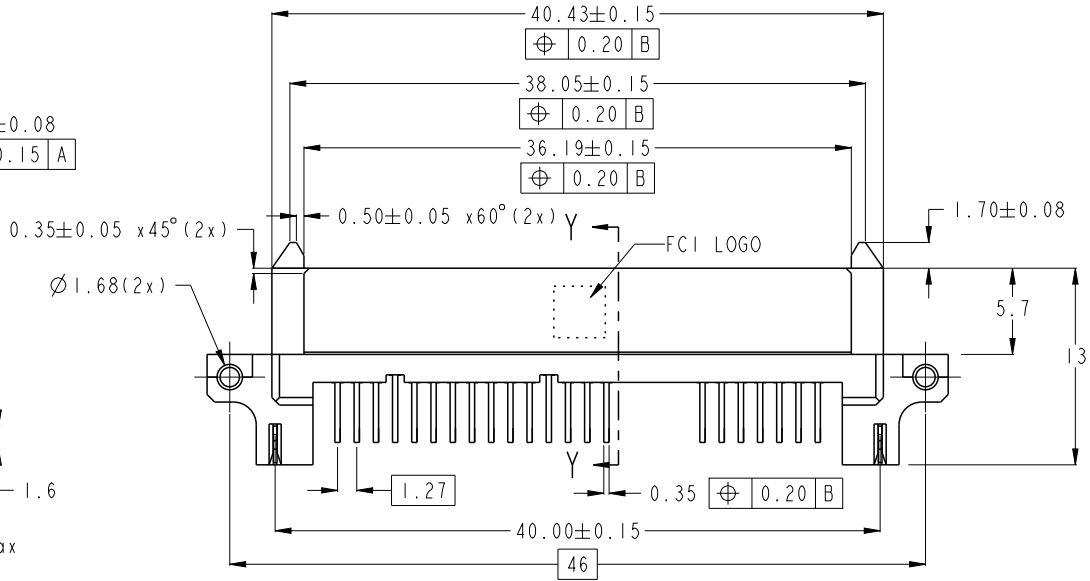
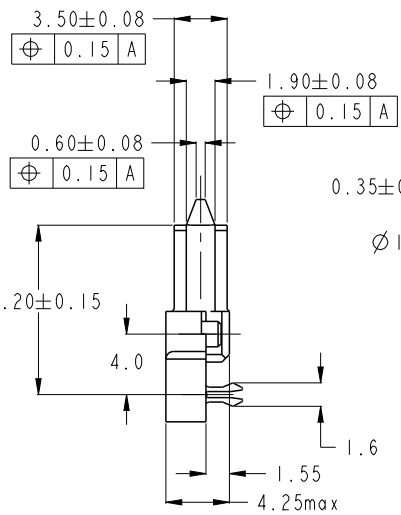
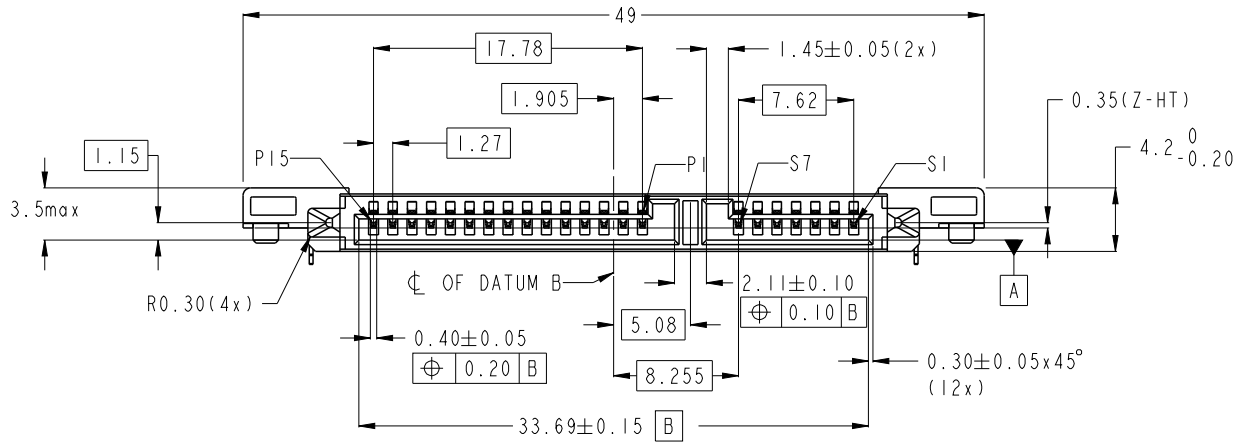

spec ref		dr <a href="#">w wcadmin</a>		2006/02/16		projection		size A4		scale 1:1	
tolerance std		eng <a href="#">Koon-Poh Tay</a>		2015/10/07						ecn no <a href="#">ELX-S-22098-1</a>	
ASME Y14.5		chr -		-						rel level <b>Released</b>	
surface <input checked="" type="checkbox"/>		appr <a href="#">Chen-Hong Tan</a>		2015/10/20		product family		dwg no 10031569		rev <b>M</b>	
				title S-ATA RECEPTACLE TOP MOUNT R/A SMT ASSY		cat. no.		Product - Customer Drw		sheet 1 of 2	
		TOLERANCES UNLESS OTHERWISE SPECIFIED linear 0.X ±0.25 0.XX ±0.20 0.XXX ±0.10 angular 0° ±°		<a href="http://www.fci.com">www.fci.com</a>							

Prod File - REV C - 2009-06-09

PRODUCT NO.	RECOMMENDED P.C.B. THICKNESS	PLATING	PACKAGING	REMARKS
10031569-001LF	1.6mm	NOTE 2	TRAY	
10031569-501LF		NOTE 8	TRAY	
10031569-501TRLF		NOTE 8	TAPE & REEL	
10031569-002LF	-	NOTE 2	TRAY	
10031569-002TRLF	-	NOTE 2	TAPE & REEL	
10031569-502LF	-	NOTE 8	TRAY	
$\Delta$ 10031569-502TRLF	-	NOTE 8	TAPE & REEL	
10031569-502CLF	-	NOTE 8	TRAY	WITH SUPPORTING CAP
10031569-502C-TRLF	-	NOTE 8	TAPE & REEL	WITH SUPPORTING CAP
10031569-012LF	-	NOTE 2	TRAY	
10031569-012TRLF	-	NOTE 2	TAPE & REEL	

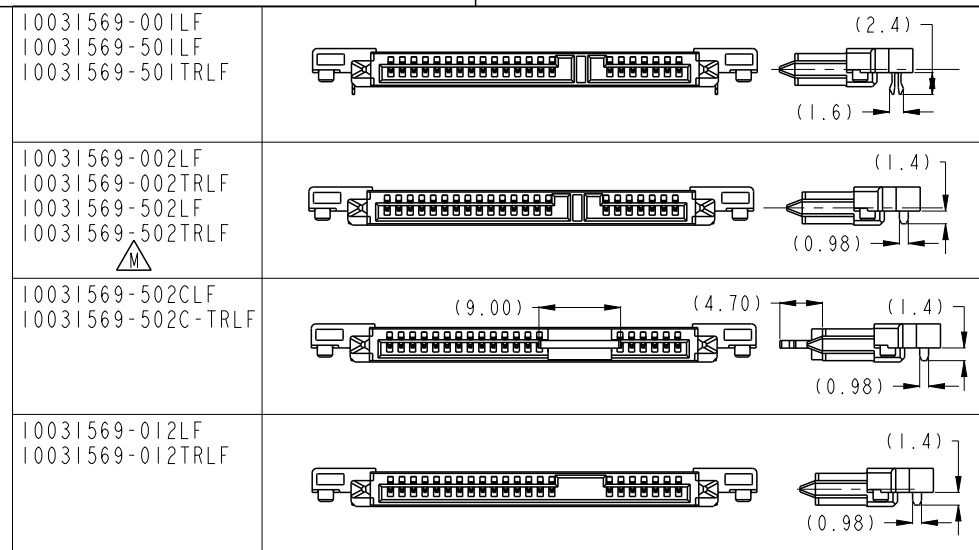

NOTES:-

1. MATERIAL:

- 1) HOUSING : HIGH TEMP. THERMOPLASTIC, UL 94V-0  
COLOR : BLACK
- 2) TERMINAL : COPPER ALLOY
- 3) HOLD DOWN : COPPER ALLOY

2. FINISH:

- 1) TERMINAL : 30u" Au PLATING (CONTACT POINT) OVER 50u" MIN NICKEL
- 2) SOLDER TAIL : 100u" MIN TIN OVER 50u" NICKEL
- 3) HOLD DOWN : 100u" MIN TIN OVER 50u" NICKEL

3. THE STANDARD PACKAGING IS IN TRAY.

4. THE HOUSING WILL WITHSTAND EXPOSURE TO 260°C PEAK TEMPERATURE FOR 10 SECONDS IN A CONVECTION, INFRA-RED OR VAPOR PHASE REFLOW OVEN.

5. THIS PRODUCT MEETS EUROPEAN UNION DIRECTIVES AND OTHER COUNTRY REGULATIONS AS DESCRIBED IN GS-47-0004

6. PART NUMBERS ENDING IN "LF" ARE MEANT FOR LEAD-FREE IDENTIFICATION. P/N XXXXXXXX-XXXLF IS EQUIVALENT TO PREVIOUS P/N XXXXXXXX-XXX

7. ALL SOLDER TAIL TO BE WITHIN 0.12mm MAX. COPLANARITY.

8. FINISH:

- 1) TERMINAL : 15u" Au PLATING (CONTACT POINT) OVER 50u" MIN NICKEL
- 2) SOLDER TAIL : 100u" MIN TIN OVER 50u" NICKEL
- 3) HOLD DOWN : 100u" MIN TIN OVER 50u" NICKEL

9. A  $\Delta$  SYMBOL WILL BE NEXT TO ANY DIMENSION, VIEW, OR NOTE WHICH HAS BEEN MODIFIED WITH THE CURRENT DRAWING REVISION.

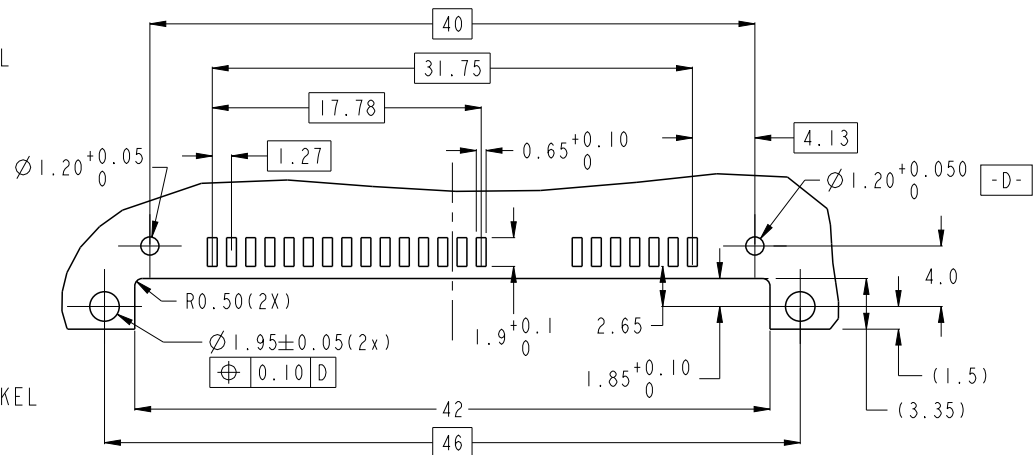

RECOMMENDED P.C.B LAYOUT  
TOLERANCE UNLESS OTHERWISE: ±0.1

spec ref		dr	wcadmin	2006/02/16	projection 	MM 	size	A4	scale	1:1
tolerance std		eng	Koon-Poh Tay	2015/10/07			ecn no	ELX-S-22098-1		
ASME Y14.5		chr	-	-				rel level	Released	
surface	linear	0.X	±0.25		title	S-ATA RECEPTACLE	dwg no	10031569	rev	M
		0.XX	±0.20							
		0.XXX	±0.10							
angular	0°	±°	www.fci.com	cat. no.	Product - Customer Drw		sheet 2 of 2			



Copyright FCI.