

PRODUCT N°  
SEE TABLE

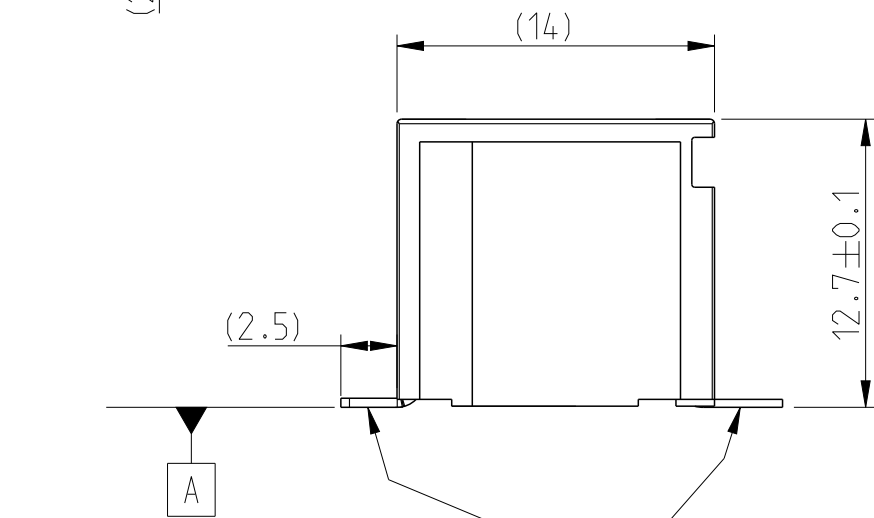
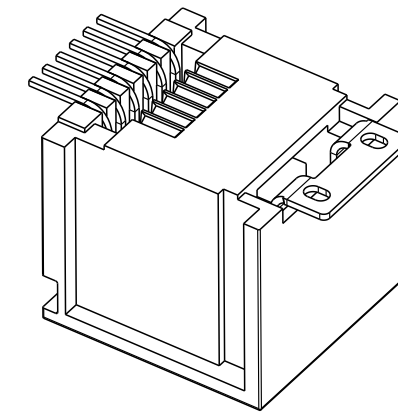
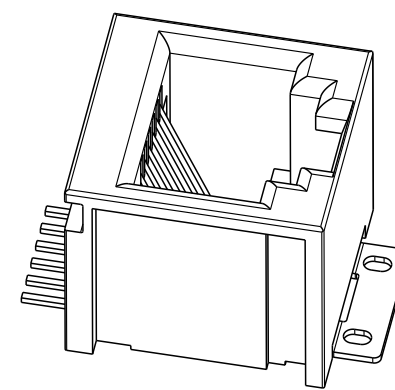
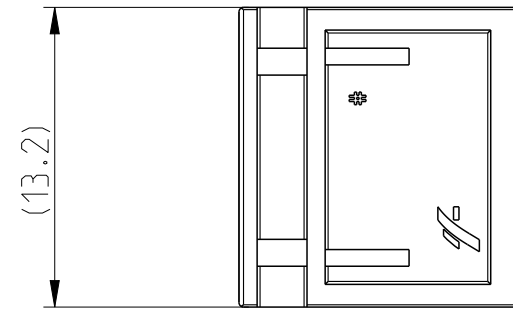
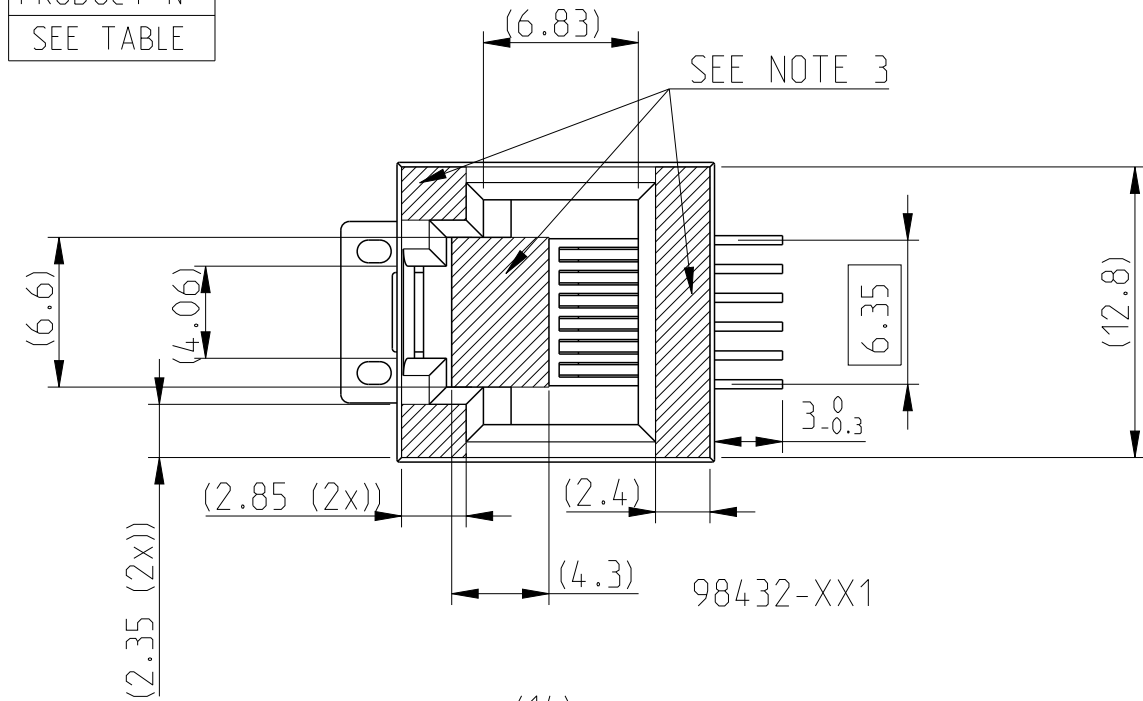

SEE NOTE 5

REFERENCE PLAN DEFINED BY THE BEARING SURFACE

0.1  
SEE NOTE 6

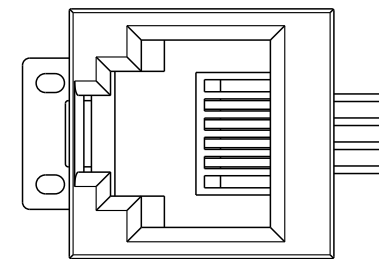

98432-XX2

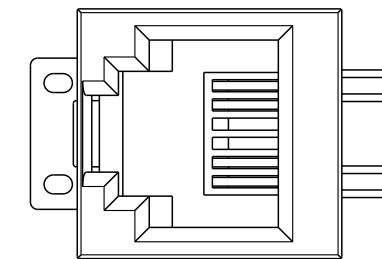

98432-XX3

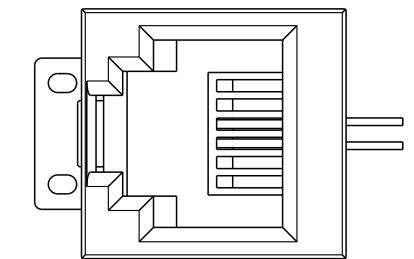

98432-XX4

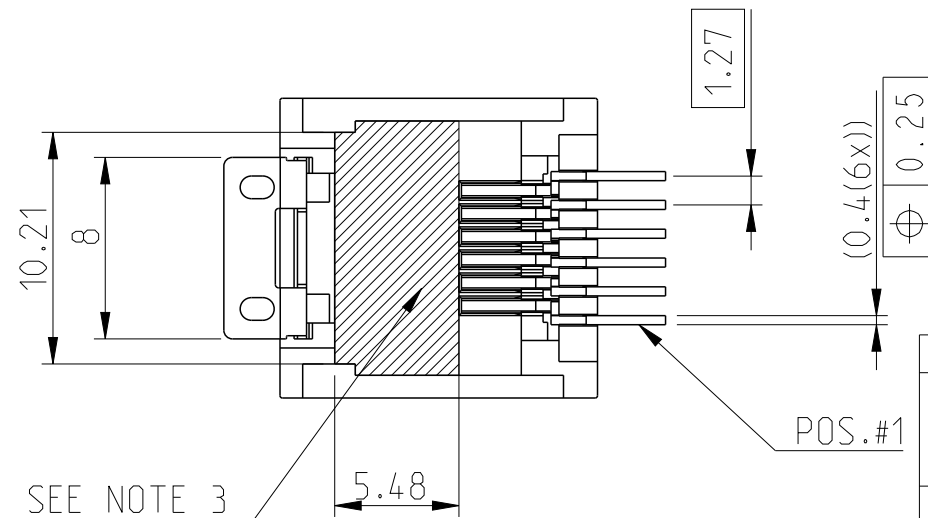

SEE NOTE 3

VACUUM AREA FOR 98432-X2XLF

spec ref	-	dr	A Parrenin	2002/09/19	projection	mm	size	A3	scale	3:1	
tolerance std	±0.13 ±2°	eng	J Dalibard	2016/02/01			ecn no	ELX-B-16041-1	rel level		Released
TOLERANCES UNLESS OTHERWISE SPECIFIED		chr	J Dalibard	2016/02/01			product family	MODULAR JACK	rel level		Released
surface	ISO 1302	appr	Aymeric Soudy	2016/02/08			dwg no	98432	rev	U	
linear	0.X ±Y 0.XX ±Y 0.XXX ±Y	www.fci.com		cat. no.	98432-XXX(LF)	Product - Customer Drw		sheet 1 of 2			
angular	0° ±Y°										

PRODUCT N°  
98432-XXXLF

CONTACT PLATING OPTION
1= GXT 0.76 μm
3= 0.76 μm GOLD
5= 1.27 μm GOLD

PACKAGE OPTIONS	VERSION	PLASTIC COLOR
TAPE AND REEL PACKAGE 1= LOADED FACE UP	TOP	BLACK
TAPE AND REEL PACKAGE 2= LOADED FACE DOWN	BOTTOM	BLACK
TAPE AND REEL PACKAGE 3= LOADED FACE UP	TOP	GREY

TERMINAL LOADING OPTIONS
1 = FULLY LOADED 6 POSITIONS
2 = ONLY POS 2,3,4,5 LOADED
3 = ONLY POS 1,2,5,6 LOADED
4 = ONLY POS 3,4 LOADED

WHEN NEEDED, SUFFIX LETTER "LF" INDICATES THE PRODUCT IS RoHS COMPATIBLE SEE NOTE 7.

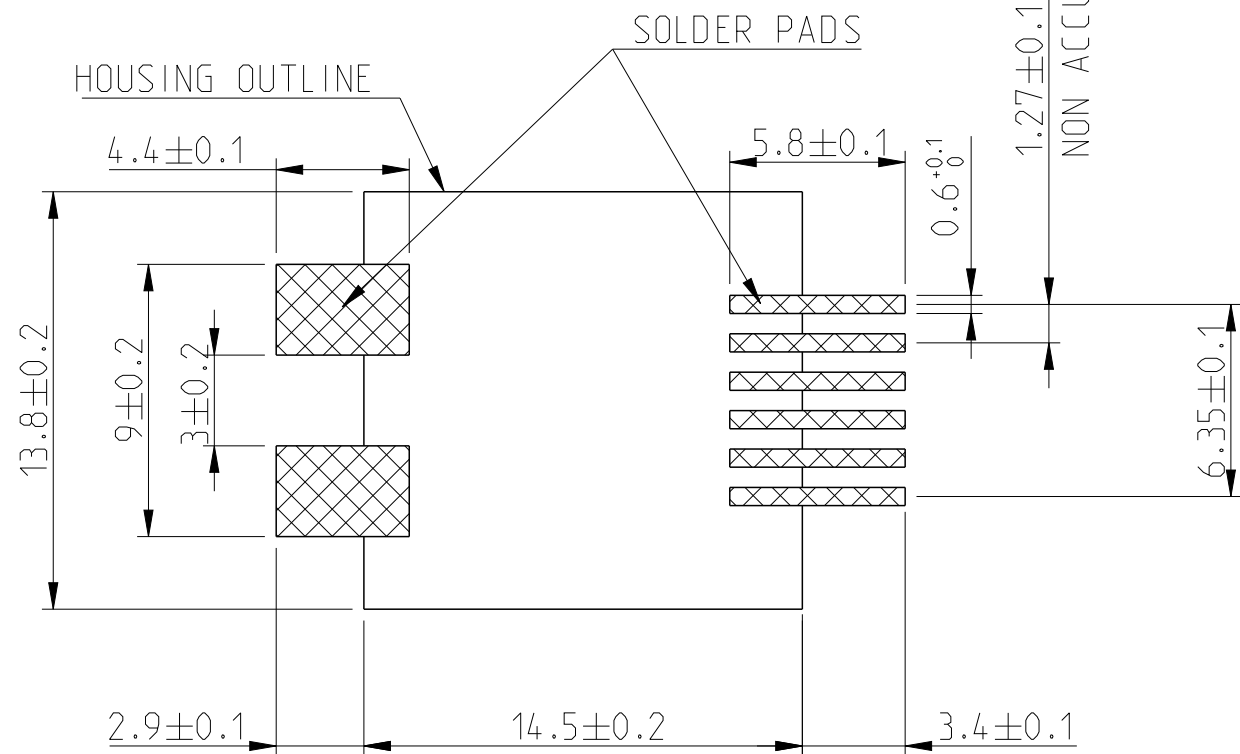
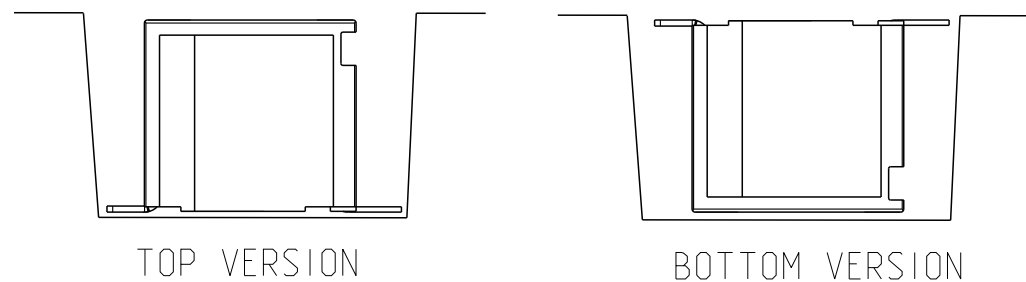

RECOMMENDED PCB FOOTPRINT

NOTES:

- 1 - MATERIAL:  
HOUSING: HIGH TEMP. PLASTIC, COLOR : SEE TABLE HERE ABOVE.  
- GWF1 IS 850 °C AT 1mm AND 960 °C AT 2mm THICKNESS OF THE PLATES.  
- GWIT IS AT 725 °C FOR 1 AND 2 mm THICKNESS OF THE PLATES.  
TERMINAL PHOSPHOR BRONZE
- 2 - PLATING  
CONTACT AREA: OPTIONAL SEE TABLE  
SOLDER TAIL: SnPb 90/10 2 μm MIN  
NO RAW EDGES EXCEPT SOLDER TAILS TIPS
- 3 - AREA FOR VACUUM PICK AND PLACE VENTURY
- 4 - PACKAGING SPECIFICATION SEE TA 858
- 5 - DIMENSION MEASURED FROM "A" TO THE TOP OF PRODUCT
- 6 - COPLANARITY SEE TA 861.
- 7 - RoHS COMPATIBLE PRODUCT SPECIFICATIONS
  - a - PLATING:  
- "LF" MEANS THE PRODUCT IS LEAD-FREE,  
2 μm MINIMUM MATTE TIN OVER 1.27 μm  
MINIMUM NICKEL UNDERPLATE.
  - b - MANUFACTURING PROCESS COMPATIBILITY:  
- THE HOUSING WILL WITHSTAND EXPOSURE TO  
245 °C PEAK TEMPERATURE FOR 30 SECONDS  
MAX IN A CONVECTION, INFRA-RED OR VAPOR  
PHASE OR REFLOW OVEN.
  - c - LABELLING:  
- MEETS PACKAGING SPECS AS PER GS-14-920.
  - d - LEGAL STATEMENT: SEE GS-22-008

spec ref	-	dr	A Parrenin	2002/09/19	projection	mm	size	A3	scale	5:1	
tolerance std	±0.13 ±2°	eng	J Dalibard	2016/02/01			ecn no	ELX-B-16041-1	rel level	Released	
TOLERANCES UNLESS OTHERWISE SPECIFIED		chr	J Dalibard	2016/02/01							
surface	ISO 1302	appr	Aymeric Soudy	2016/02/08	product family	MODULAR JACK	dwg no		98432	rev	U
	linear										
	angular										
	0.X										
	0.XX										
	0.XXX										
	0°										
	±Y										
	±Y										
	±Y										
	±Y°										
www.fci.com	cat. no.	98432-XXX(LF)		Product - Customer Drw	sheet 2 of 2						