

AD7796/AD7797

TABLE OF CONTENTS

Features	1	ID Register.....	14
Interface	1	Offset Register	15
Applications.....	1	Full-Scale Register	15
General Description	1	ADC Circuit Information.....	16
Functional Block Diagram	1	Overview	16
Revision History	2	Digital Interface	17
Specifications.....	3	Circuit Description.....	20
Timing Characteristics.....	5	Analog Input Channel	20
Timing Diagrams.....	6	Bipolar/Unipolar Configuration	20
Absolute Maximum Ratings.....	7	Data Output Coding	20
Thermal Resistance	7	Reference	20
ESD Caution.....	7	Reset	21
Pin Configuration and Function Descriptions.....	8	Burnout Currents	21
RMS Noise and Resolution Specifications	9	AV _{DD} Monitor	21
Typical Performance Characteristics	10	Temperature Monitor	21
On-Chip Registers	11	Calibration.....	21
Communication Register	11	Grounding and Layout	22
Status Register	12	Applications.....	23
Mode Register	12	Weigh Scales.....	23
Configuration Register	14	Outline Dimensions	24
Data Register	14	Ordering Guide	24

REVISION HISTORY

8/06—Rev. 0 to Rev. A.

Changes to Table 1.....	3
Changes to Figure 5.....	8
Changes to Table 14.....	13

7/06—Revision 0: Initial Version

SPECIFICATIONS

$AV_{DD} = 2.7\text{ V to }5.25\text{ V}$, $DV_{DD} = 2.7\text{ V to }5.25\text{ V}$, $GND = 0\text{ V}$, all specifications T_{MIN} to T_{MAX} , unless otherwise noted.

Table 1.

Parameter	AD7796B/AD7797B ¹	Unit	Test Conditions/Comments
ADC CHANNEL			
Output Update Rate	4.17 to 123	Hz nom	
No Missing Codes ²	24	Bits min	AD7797 only
	16	Bits min	AD7796 only
Resolution	See Table 7 and Table 8		
RMS Noise and Update Rates	See Table 6		
Integral Nonlinearity	±10	ppm of FSR typ	
Offset Error ^{3,4}	±1	µV typ	
Offset Error Drift vs. Temperature ⁴	±10	nV/°C typ	
Full-Scale Error ^{3,4,5}	±10	µV typ	
Gain Drift vs. Temperature ⁴	±3	ppm/°C typ	
Power Supply Rejection	90	dB min	AIN = 1 V/128
ANALOG INPUTS			
Differential Input Voltage Ranges	± $V_{REF}/128$	V nom	$V_{REF} = REF_{IN}(+) - REF_{IN}(-)$
Absolute AIN Voltage Limits ²	GND + 300 mV	V min	
	$AV_{DD} - 1.1$	V max	
Common-Mode Voltage, V_{CM}	0.5	V min	$V_{CM} = (AIN(+)) + AIN(-))/2$
Analog Input Current			
Average Input Current ²	±250	pA max	Update rate < 100 Hz
Average Input Current Drift	±2	pA/°C typ	
Normal Mode Rejection ²			
Internal Clock			
@ 50 Hz, 60 Hz	65	dB min	80 dB typ, 50 ± 1 Hz, 60 ± 1 Hz, FS[3:0] = 1010 ⁶
@ 50 Hz	80	dB min	90 dB typ, 50 ± 1 Hz, FS[3:0] = 1001 ⁶
@ 60 Hz	90	dB min	100 dB typ, 60 ± 1 Hz, FS[3:0] = 1000 ⁶
External Clock			
@ 50 Hz, 60 Hz	80	dB min	90 dB typ, 50 ± 1 Hz, 60 ± 1 Hz, FS[3:0] = 1010 ⁶
@ 50 Hz	94	dB min	100 dB typ, 50 ± 1 Hz, FS[3:0] = 1001 ⁶
@ 60 Hz	90	dB min	100 dB typ, 60 ± 1 Hz, FS[3:0] = 1000 ⁶
Common-Mode Rejection			
@ DC	90	dB min	AIN = 7.81 mV
@ 50 Hz, 60 Hz ²	90	dB min	50 ± 1 Hz, 60 ± 1 Hz, FS[3:0] = 1010 ⁶
@ 50 Hz, 60 Hz ²	90	dB min	50 ± 1 Hz (FS[3:0] = 1001 ⁶), 60 ± 1 Hz, FS[3:0] = 1000 ⁶
REFERENCE			
External REF _{IN} Voltage	2.5	V nom	REF _{IN} = REF _{IN} (+) - REF _{IN} (-)
Reference Voltage Range ²	0.1	V min	
	AV_{DD}	V max	
Absolute REF _{IN} Voltage Limits ²	GND - 30 mV	V min	
	$AV_{DD} + 30\text{ mV}$	V max	
Average Reference Input Current	400	nA/V typ	
Average Reference Input Current Drift	±0.03	nA/V/°C typ	
Normal Mode Rejection	Same as for analog inputs		
Common-Mode Rejection	100	dB typ	
TEMPERATURE SENSOR			
Accuracy	±2	°C typ	Applies if user calibrates the temperature sensor
Sensitivity	0.81	mV/°C typ	

AD7796/AD7797

Parameter	AD7796B/AD7797B ¹	Unit	Test Conditions/Comments
INTERNAL/EXTERNAL CLOCK			
Internal Clock			
Frequency ²	64 ± 3%	kHz min/max	
Duty Cycle	50:50	% typ	
External Clock			
Frequency	64	kHz nom	A 128 kHz clock can be used if the divide by 2 function is used (Bit CLK1 = CLK0 = 1)
Duty Cycle	45:55 to 55:45	% typ	Applies for external 64 kHz clock (a 128 kHz clock can have a less stringent duty cycle)
LOGIC INPUTS			
\overline{CS}^2			
Input Low Voltage, V_{INL}	0.8	V max	$DV_{DD} = 5\text{ V}$
Input High Voltage, V_{INH}	0.4	V max	$DV_{DD} = 3\text{ V}$
Input High Voltage, V_{INH}	2.0	V min	$DV_{DD} = 3\text{ V or }5\text{ V}$
SCLK, CLK, and DIN (Schmitt-Triggered Input) ²			
$V_{T(+)}$	1.4/2	V min/V max	$DV_{DD} = 5\text{ V}$
$V_{T(-)}$	0.8/1.7	V min/V max	$DV_{DD} = 5\text{ V}$
$V_{T(+)} - V_{T(-)}$	0.1/0.17	V min/V max	$DV_{DD} = 5\text{ V}$
$V_{T(+)}$	0.9/2	V min/V max	$DV_{DD} = 3\text{ V}$
$V_{T(-)}$	0.4/1.35	V min/V max	$DV_{DD} = 3\text{ V}$
$V_{T(+)} - V_{T(-)}$	0.06/0.13	V min/V max	$DV_{DD} = 3\text{ V}$
Input Currents	±10	µA max	$V_{IN} = DV_{DD}$ or GND
Input Capacitance	10	pF typ	All digital inputs
LOGIC OUTPUTS (INCLUDING CLK)			
Output High Voltage, V_{OH}^2	$DV_{DD} - 0.6$	V min	$DV_{DD} = 3\text{ V}, I_{SOURCE} = 100\text{ }\mu\text{A}$
Output High Voltage, V_{OH}^2	4	V min	$DV_{DD} = 5\text{ V}, I_{SOURCE} = 200\text{ }\mu\text{A}$
Output Low Voltage, V_{OL}^2	0.4	V max	$DV_{DD} = 3\text{ V}, I_{SINK} = 100\text{ }\mu\text{A}$
Output Low Voltage, V_{OL}^2	0.4	V max	$DV_{DD} = 5\text{ V}, I_{SINK} = 1.6\text{ mA (DOUT/RDY)}/800\text{ }\mu\text{A (CLK)}$
Floating-State Leakage Current	±10	µA max	
Floating-State Output Capacitance	10	pF typ	
Data Output Coding	Offset Binary		
SYSTEM CALIBRATION ²			
Full-Scale Calibration Limit	+1.05 × FS	V max	
Zero-Scale Calibration Limit	-1.05 × FS	V min	
Input Span	0.8 × FS	V min	
Input Span	2.1 × FS	V max	
POWER REQUIREMENTS ⁷			
Power Supply Voltage			
$AV_{DD} - \text{GND}$	2.7/5.25	V min/max	
$DV_{DD} - \text{GND}$	2.7/5.25	V min/max	
Power Supply Currents			
I_{DD} Current	325	µA max	250 µA typ @ $AV_{DD} = 3\text{ V}$, 280 µA typ @ $AV_{DD} = 5\text{ V}$
I_{DD} (Power-Down Mode)	1	µA max	

¹ Temperature range is -40°C to +85°C.

² Specification is not production tested, but is supported by characterization data at initial product release.

³ Following a calibration, this error is in the order of the noise for the update rate selected.

⁴ Recalibration at any temperature removes these errors.

⁵ Full-scale error applies to both positive and negative full-scale and applies at the factory calibration conditions ($AV_{DD} = 4\text{ V}$, $T_A = 25^\circ\text{C}$).

⁶ FS[3:0] are the four bits used in the mode register to select the output word rate.

⁷ Digital inputs equal to DV_{DD} or GND.

TIMING CHARACTERISTICS

$AV_{DD} = 2.7\text{ V to }5.25\text{ V}$, $DV_{DD} = 2.7\text{ V to }5.25\text{ V}$, $GND = 0\text{ V}$, Input Logic 0 = 0 V, Input Logic 1 = DV_{DD} , unless otherwise noted.

Table 2.

Parameter ^{1, 2}	Limit at T_{MIN} , T_{MAX} (B Version)	Unit	Conditions/Comments
t_3	100	ns min	SCLK high pulse width
t_4	100	ns min	SCLK low pulse width
Read Operation			
t_1	0	ns min	\overline{CS} falling edge to $DOUT/\overline{RDY}$ active time
	60	ns max	$DV_{DD} = 4.75\text{ V to }5.25\text{ V}$
	80	ns max	$DV_{DD} = 2.7\text{ V to }3.6\text{ V}$
t_2^3	0	ns min	SCLK active edge to data valid delay ⁴
	60	ns max	$DV_{DD} = 4.75\text{ V to }5.25\text{ V}$
	80	ns max	$DV_{DD} = 2.7\text{ V to }3.6\text{ V}$
$t_5^{5, 6}$	10	ns min	Bus relinquish time after \overline{CS} inactive edge
	80	ns max	
t_6	0	ns min	SCLK inactive edge to \overline{CS} inactive edge
t_7	10	ns min	SCLK inactive edge to $DOUT/\overline{RDY}$ high
Write Operation			
t_8	0	ns min	\overline{CS} falling edge to SCLK active edge setup time ⁴
t_9	30	ns min	Data valid to SCLK edge setup time
t_{10}	25	ns min	Data valid to SCLK edge hold time
t_{11}	0	ns min	\overline{CS} rising edge to SCLK edge hold time

¹ Sample tested during initial release to ensure compliance. All input signals are specified with $t_r = t_f = 5\text{ ns}$ (10% to 90% of DV_{DD}) and timed from a voltage level of 1.6 V.

² See Figure 3 and Figure 4.

³ These numbers are measured with the load circuit of Figure 2 and defined as the time required for the output to cross the V_{OL} or V_{OH} limits.

⁴ SCLK active edge is falling edge of SCLK.

⁵ These numbers are derived from the measured time taken by the data output to change 0.5 V when loaded with the circuit of Figure 2. The measured number is then extrapolated back to remove the effects of charging or discharging the 50 pF capacitor. This means that the times quoted in the timing characteristics are the true bus relinquish times of the parts and, as such, are independent of external bus loading capacitances.

⁶ \overline{RDY} returns high after a read of the ADC. In single conversion mode and continuous conversion mode, the same data can be read again, if required, while \overline{RDY} is high. Care should be taken to ensure that subsequent reads do not occur close to the next output update. In continuous read mode, the digital word can be read only once.

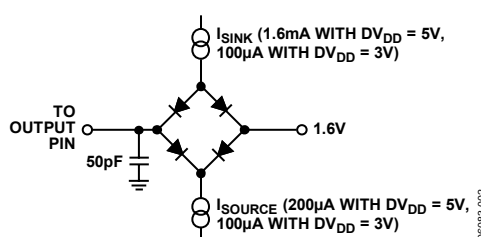

Figure 2. Load Circuit for Timing Characterization

AD7796/AD7797

TIMING DIAGRAMS

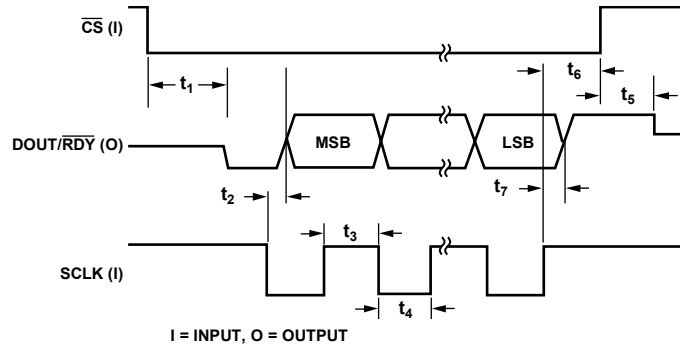

Figure 3. Read Cycle Timing Diagram

06063-003

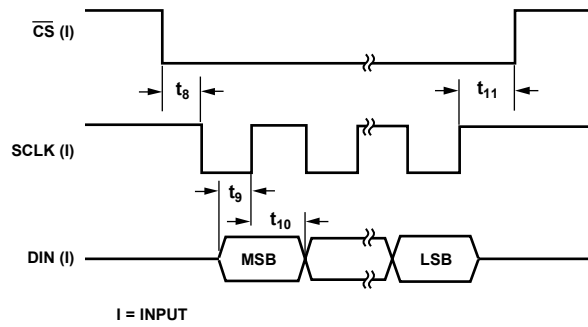

Figure 4. Write Cycle Timing Diagram

06063-004

ABSOLUTE MAXIMUM RATINGS

$T_A = 25^\circ\text{C}$, unless otherwise noted.

Table 3.

Parameter	Rating
AV_{DD} to GND	-0.3 V to +7 V
DV_{DD} to GND	-0.3 V to +7 V
Analog Input Voltage to GND	-0.3 V to $AV_{DD} + 0.3$ V
Reference Input Voltage to GND	-0.3 V to $AV_{DD} + 0.3$ V
Digital Input Voltage to GND	-0.3 V to $DV_{DD} + 0.3$ V
Digital Output Voltage to GND	-0.3 V to $DV_{DD} + 0.3$ V
AIN/Digital Input Current	10 mA
Operating Temperature Range	-40°C to $+85^\circ\text{C}$
Storage Temperature Range	-65°C to $+150^\circ\text{C}$
Maximum Junction Temperature	150°C
Lead Temperature, Soldering	
Vapor Phase (60 sec)	215°C
Infrared (15 sec)	220°C

Stresses above those listed under Absolute Maximum Ratings may cause permanent damage to the device. This is a stress rating only; functional operation of the device at these or any other conditions above those indicated in the operational section of this specification is not implied. Exposure to absolute maximum rating conditions for extended periods may affect device reliability.

THERMAL RESISTANCE

θ_{JA} is specified for the worst-case conditions, that is, a device soldered in a circuit board for surface-mount packages.

Table 4.

Package Type	θ_{JA}	θ_{JC}	Unit
TSSOP	128	14	$^\circ\text{C}/\text{W}$

ESD CAUTION



ESD (electrostatic discharge) sensitive device.

Charged devices and circuit boards can discharge without detection. Although this product features patented or proprietary protection circuitry, damage may occur on devices subjected to high energy ESD. Therefore, proper ESD precautions should be taken to avoid performance degradation or loss of functionality.

AD7796/AD7797

PIN CONFIGURATION AND FUNCTION DESCRIPTIONS

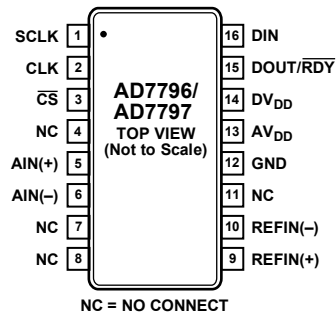

Figure 5. Pin Configuration

Table 5. Pin Function Descriptions

Pin No.	Mnemonic	Description
1	SCLK	Serial Clock Input. This serial clock input is for data transfers to and from the ADC. The SCLK has a Schmitt-triggered input, making the interface suitable for opto-isolated applications. The serial clock can be continuous with all data transmitted in a constant train of pulses. Alternatively, it can be a noncontinuous clock with the information being transmitted to or from the ADC in smaller batches of data.
2	CLK	Clock In/Clock Out. The internal clock can be made available at this pin. Alternatively, the internal clock can be disabled, and the ADC can be driven by an external clock. This allows several ADCs to be driven from a common clock, allowing simultaneous conversions to be performed.
3	$\overline{\text{CS}}$	Chip Select Input. This is an active low logic input used to select the ADC. $\overline{\text{CS}}$ can be used to select the ADC in systems with more than one device on the serial bus or as a frame synchronization signal in communicating with the device. $\overline{\text{CS}}$ can be hardwired low, allowing the ADC to operate in 3-wire mode with SCLK, DIN, and DOUT used to interface with the device.
4	NC	No Connect.
5	AIN(+)	Analog Input. AIN(+) is the positive terminal of the differential analog input pair AIN(+)/AIN(-).
6	AIN(-)	Analog Input. AIN(-) is the negative terminal of the differential analog input pair AIN(+)/AIN(-).
7	NC	No Connect.
8	NC	No Connect.
9	REFIN(+)	Positive Reference Input/Analog Input. An external reference can be applied between REFIN(+) and REFIN(-). REFIN(+) can lie anywhere between AV_{DD} and $\text{GND} + 0.1 \text{ V}$. The nominal reference voltage ($\text{REFIN}(+) - \text{REFIN}(-)$) is 2.5 V, but the parts function with a reference of 0.1 V to AV_{DD} .
10	REFIN(-)	Negative Reference Input/Analog Input. REFIN(-) is the negative reference input for REFIN. This reference input can lie anywhere between GND and $\text{AV}_{\text{DD}} - 0.1 \text{ V}$.
11	NC	No Connect.
12	GND	Ground Reference Point.
13	AV_{DD}	Supply Voltage, 2.7 V to 5.25 V.
14	DV_{DD}	Digital Interface Supply Voltage. The logic levels for the serial interface pins are related to this supply, which is between 2.7 V and 5.25 V. The DV_{DD} voltage is independent of the voltage on AV_{DD} ; therefore, AV_{DD} can equal 5 V with DV_{DD} at 3 V or vice versa.
15	$\text{DOUT}/\overline{\text{RDY}}$	Serial Data Output/Data Ready Output. $\text{DOUT}/\overline{\text{RDY}}$ serves a dual purpose. It functions as a serial data output pin to access the output shift register of the ADC. The output shift register can contain data from any of the on-chip data or control registers. In addition, $\text{DOUT}/\overline{\text{RDY}}$ operates as a data ready pin, going low to indicate the completion of a conversion. If the data is not read after the conversion, the pin goes high before the next update occurs. The $\text{DOUT}/\overline{\text{RDY}}$ falling edge can be used as an interrupt to a processor, indicating that valid data is available. With an external serial clock, the data can be read using the $\text{DOUT}/\overline{\text{RDY}}$ pin. With $\overline{\text{CS}}$ low, the data/control word information is placed on the $\text{DOUT}/\overline{\text{RDY}}$ pin on the SCLK falling edge and is valid on the SCLK rising edge.
16	DIN	Serial Data Input. This serial data input accesses the input shift register on the ADC. Data in this shift register is transferred to the control registers within the ADC; the register selection bits of the communication register identify the appropriate register.

RMS NOISE AND RESOLUTION SPECIFICATIONS

Table 6 shows the rms noise of the AD7796/AD7797 for some of the update rates. The numbers given are for the bipolar input range with an external 2.5 V reference. These numbers are typical and are generated with a differential input voltage of 0 V. Table 7 and Table 8 show the effective resolution, while the output peak-to-peak (p-p) resolution is shown in brackets. It is important to note that the effective resolution is calculated using the rms noise, while the p-p resolution is based on the p-p noise. The p-p resolution represents the resolution for which there is no code flicker. These numbers are typical and are rounded to the nearest 0.5 LSB.

Table 6. RMS Noise (μV) vs. Output Update Rate for the AD7796/AD7797 Using a 2.5 V Reference

Update Rate (Hz)	RMS Noise (μV)
4.17	0.065
6.25	0.07
8.33	0.08
10	0.09
12.5	0.1
16.7	0.12
33.2	0.17
50	0.21
62	0.23
123	0.43

Table 7. Typical Resolution (Bits) vs. Output Update Rate for the AD7797 Using a 2.5 V Reference

Update Rate (Hz)	Effective Bits (p-p)
4.17	19 (16.5)
6.25	19 (16.5)
8.33	19 (16)
10	18.5 (16)
12.5	18.5 (16)
16.7	18.5 (15.5)
33.2	18 (15)
50	17.5 (15)
62	17.5 (14.5)
123	16.5 (13.5)

Table 8. Typical Resolution (Bits) vs. Output Update Rate for the AD7796 Using a 2.5 V Reference

Update Rate (Hz)	Effective Bits (p-p)
4.17	16 (16)
6.25	16 (16)
8.33	16 (16)
10	16 (16)
12.5	16 (16)
16.7	16 (15.5)
33.2	16 (15)
50	16 (15)
62	16 (14.5)
123	16 (13.5)

AD7796/AD7797

TYPICAL PERFORMANCE CHARACTERISTICS

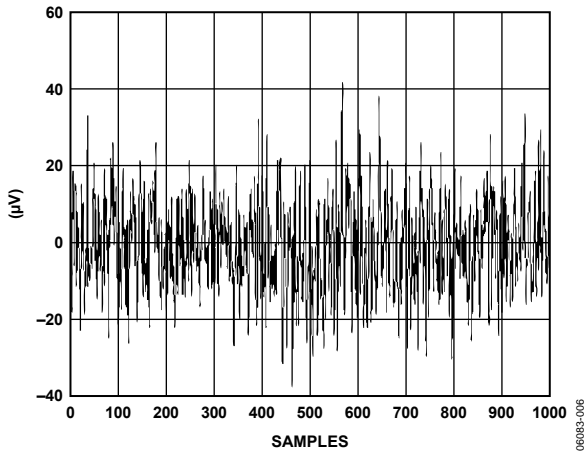

Figure 6. AD7797 Noise ($V_{REF} = AV_{DD}$, Update Rate = 16.7 Hz)

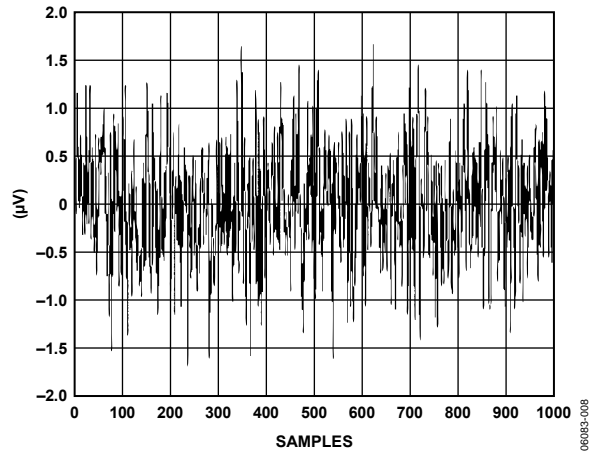

Figure 8. AD7797 Noise ($V_{REF} = AV_{DD}$, Update Rate = 4.17 Hz)

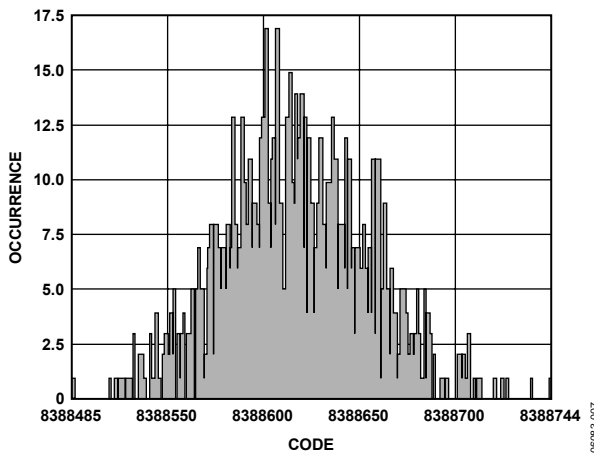

Figure 7. AD7797 Noise Distribution Histogram ($V_{REF} = AV_{DD}$, Update Rate = 16.7 Hz)

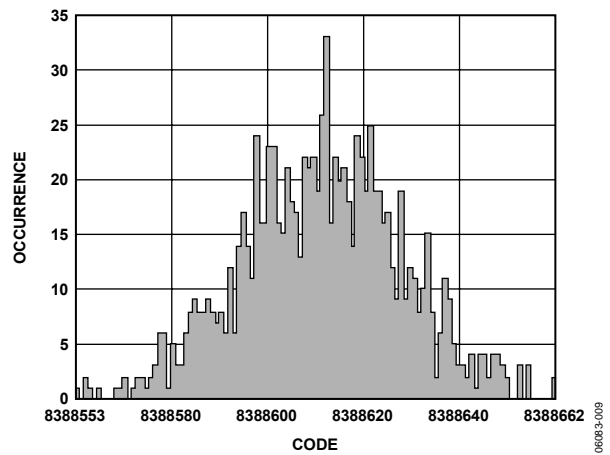

Figure 9. AD7797 Noise Distribution Histogram ($V_{REF} = AV_{DD}$, Update Rate = 4.17 Hz)

ON-CHIP REGISTERS

The ADC is controlled and configured via a number of on-chip registers, which are described on the following pages. In the following descriptions, *set* implies a Logic 1 State and *cleared* implies a Logic 0 State, unless otherwise stated.

COMMUNICATION REGISTER

RS2, RS1, RS0 = 0, 0, 0

The communication register is an 8-bit write-only register. All communication to the part must start with a write operation to this register. The data written to the communication register determines whether the next operation is a read or write operation, and selects the register where this operation takes place.

Once the subsequent read or write operation to the selected register is complete, the interface returns to where it expects a write operation to the communication register (this is the default state of the interface). On power-up or after a reset, the ADC is in this default state waiting for a write operation to the communication register. In situations where the interface sequence is lost, a write operation of at least 32 serial clock cycles with DIN high returns the ADC to this default state by resetting the entire part. Table 9 outlines the bit designations for the communication register. CR0 through CR7 indicate the bit location, with CR denoting that the bits are in the communication register. CR7 denotes the first bit of the data stream. The number in brackets indicates the power-on/reset default status of that bit.

MSB				LSB			
CR7	CR6	CR5	CR4	CR3	CR2	CR1	CR0
WEN(0)	R/W(0)	RS2(0)	RS1(0)	RS0(0)	CREAD(0)	0(0)	0(0)

Table 9. Communication Register Bit Designations

Bit Location	Bit Name	Description
CR7	WEN	Write Enable Bit. A 0 must be written to this bit first to ensure that a write to the communication register occurs. If a 1 is the first bit written, the part does not clock onto subsequent bits in the register; it stays at this bit location until a 0 is written. Once a 0 is written to the WEN bit, the next seven bits are loaded to the communication register.
CR6	R/W	A 0 in this bit location indicates that the next operation is a write to a specified register. A 1 in this position indicates that the next operation is a read from the designated register.
CR5 to CR3	RS2 to RS0	Register Address Bits. These address bits determine which ADC registers are being selected during this serial interface communication. See Table 10.
CR2	CREAD	Continuous Read of the Data Register. When this bit is set to 1 (and the data register is selected), the serial interface is configured to continuously read the data register. For example, the contents of the data register are automatically placed on the DOUT pin when the SCLK pulses are applied and after the RDY pin goes low. This indicates that a conversion is complete. The communication register does not have to be written to for data reads. To enable continuous read mode, the instruction 01011100 must be written to the communication register. To exit the continuous read mode, the instruction 01011000 must be written to the communication register while the RDY pin is low. While in continuous read mode, the ADC monitors activity on the DIN line so it can receive the instruction to exit continuous read mode. Additionally, a reset occurs if 32 consecutive 1s are seen on DIN. Therefore, DIN should be held low in continuous read mode until an instruction is written to the device.
CR1 to CR0	0	These bits must be programmed to Logic 0 for correct operation.

Table 10. Register Selection

RS2	RS1	RS0	Register	Register Size
0	0	0	Communication Register During a Write Operation	8 bits
0	0	0	Status Register During a Read Operation	8 bits
0	0	1	Mode Register	16 bits
0	1	0	Configuration Register	16 bits
0	1	1	Data Register	16 bits (AD7796), 24 bits (AD7797)
1	0	0	ID Register	8 bits
1	0	1	Reserved	8 bits
1	1	0	Offset Register	16 bits (AD7796), 24 bits (AD7797)
1	1	1	Full-Scale Register	16 bits (AD7796), 24 bits (AD7797)

AD7796/AD7797

STATUS REGISTER

RS2, RS1, RS0 = 0, 0, 0; Power-On/Reset = 0x80

The status register is an 8-bit read-only register. To access the ADC status register, the user must write to the communication register, select the next operation to be a read, and load Bit RS2, Bit RS1, and Bit RS0 with 0. Table 11 outlines the bit designations for the status register. SR0 through SR7 indicate the bit locations, with SR denoting that the bits are in the status register. SR7 denotes the first bit of the data stream. The number in brackets indicates the power-on/reset default status of that bit.

MSB							LSB
SR7	SR6	SR5	SR4	SR3	SR2	SR1	SR0
RDY(1)	ERR(0)	0(0)	0(0)	0(0)	CH2(0)	CH1(0)	CH0(0)

Table 11. Status Register Bit Designations

Bit Location	Bit Name	Description
SR7	RDY	Ready Bit for ADC. <i>Cleared</i> when data is written to the ADC data register. <i>Set</i> automatically after the ADC data register has been read or before the data register is updated with a new conversion result to indicate to the user not to read the conversion data. It is also <i>set</i> when the part is placed in power-down mode. DOUT/RDY also indicates the end of a conversion and can be used as an alternative to the status register for monitoring the ADC for conversion data.
SR6	ERR	ADC Error Bit. This bit is written to at the same time as the RDY bit. <i>Set</i> to indicate that the result written to the ADC data register has been clamped to all 0s or all 1s. Error sources include overrange and underrange. <i>Cleared</i> by a write operation to start a conversion.
SR5 to SR3	0	These bits are automatically <i>cleared</i> .
SR2 to SR0	CH2 to CH0	These bits indicate the channel that is being converted by the ADC.

MODE REGISTER

RS2, RS1, RS0 = 0, 0, 1; Power-On/Reset = 0x000A

The mode register is a 16-bit read/write register. This register is used to select the operating mode, update rate, and clock source. Table 12 outlines the bit designations for this register. MR0 through MR15 indicate the bit locations, with MR denoting that the bits are in the mode register. MR15 denotes the first bit of the data stream. The number in brackets indicates the power-on/reset default status of that bit. Any write to the setup register resets the modulator and filter, and sets the RDY bit.

MSB														LSB	
MR15	MR14	MR13	MR12	MR11	MR10	MR9	MR8	MR7	MR6	MR5	MR4	MR3	MR2	MR1	MR0
MD2(0)	MD1(0)	MD0(0)	0(0)	0(0)	0(0)	0(0)	0(0)	CLK1(0)	CLK0(0)	0(0)	0(0)	FS3(1)	FS2(0)	FS1(1)	FS0(0)

Table 12. Mode Register Bit Designations

Bit Location	Bit Name	Description															
MR15 to MR13	MD2 to MD0	Mode Select Bits. These bits select the operational mode of the AD7796/AD7797 (see Table 13).															
MR12 to MR8	0	These bits must be programmed with a Logic 0 for correct operation.															
MR7 to MR6	CLK1 to CLK0	These bits are used to select the clock source for the AD7796/AD7797. Either an on-chip 64 kHz clock or an external clock can be used. The ability to override using an external clock allows several AD7796/AD7797 devices to be synchronized. In addition, 50 Hz/60 Hz rejection is improved when an accurate external clock drives the AD7796/AD7797.															
		<table border="1"> <thead> <tr> <th>CLK1</th> <th>CLK0</th> <th>ADC Clock Source</th> </tr> </thead> <tbody> <tr> <td>0</td> <td>0</td> <td>Internal 64 kHz Clock. Internal clock is not available at the CLK pin.</td> </tr> <tr> <td>0</td> <td>1</td> <td>Internal 64 kHz Clock. This clock is made available at the CLK pin.</td> </tr> <tr> <td>1</td> <td>0</td> <td>External 64 kHz Clock Used. An external clock gives better 50 Hz/60 Hz rejection. See Table 1 for the external clock specifications.</td> </tr> <tr> <td>1</td> <td>1</td> <td>External Clock Used. The external clock is divided by 2 within the AD7796/AD7797.</td> </tr> </tbody> </table>	CLK1	CLK0	ADC Clock Source	0	0	Internal 64 kHz Clock. Internal clock is not available at the CLK pin.	0	1	Internal 64 kHz Clock. This clock is made available at the CLK pin.	1	0	External 64 kHz Clock Used. An external clock gives better 50 Hz/60 Hz rejection. See Table 1 for the external clock specifications.	1	1	External Clock Used. The external clock is divided by 2 within the AD7796/AD7797.
CLK1	CLK0	ADC Clock Source															
0	0	Internal 64 kHz Clock. Internal clock is not available at the CLK pin.															
0	1	Internal 64 kHz Clock. This clock is made available at the CLK pin.															
1	0	External 64 kHz Clock Used. An external clock gives better 50 Hz/60 Hz rejection. See Table 1 for the external clock specifications.															
1	1	External Clock Used. The external clock is divided by 2 within the AD7796/AD7797.															
MR5 to MR4	0	These bits must be programmed with a Logic 0 for correct operation.															
MR3 to MR0	FS3 to FS0	Filter Update Rate Select Bits (see Table 14).															

Table 13. Operating Modes

MD2	MD1	MD0	Mode
0	0	0	Continuous Conversion Mode (default). In continuous conversion mode, the ADC continuously performs conversions and places the result in the data register. \overline{RDY} goes low when a conversion is complete. The user can read these conversions by placing the device in continuous read mode, whereby the conversions are automatically placed on the DOUT line when SCLK pulses are applied. Alternatively, the user can instruct the ADC to output the conversion by writing to the communication register. After a power-on, channel change, or write to the mode or configuration register, the first conversion is available after a period of $2/f_{ADC}$, while subsequent conversions are available at a frequency of f_{ADC} .
0	0	1	Single Conversion Mode. When single conversion mode is selected, the ADC powers up and performs a single conversion. The oscillator requires 1 ms to power up and settle. The ADC then performs the conversion, which takes a time of $2/f_{ADC}$. The conversion result is placed in the data register, \overline{RDY} goes low, and the ADC returns to power-down mode. The conversion remains in the data register and \overline{RDY} remains active (low) until the data is read or another conversion is performed.
0	1	0	Idle Mode. In idle mode, the ADC filter and modulator are held in a reset state although the modulator clocks are still provided.
0	1	1	Power-Down Mode. In power-down mode, all the AD7796/AD7797 circuitry is powered down, including the burnout currents and CLKOUT circuitry.
1	0	0	Internal Zero-Scale Calibration. An internal short is automatically connected to the channel. A calibration takes two conversion cycles to complete. \overline{RDY} goes high when the calibration is initiated and returns low when the calibration is complete. The ADC is placed in idle mode following a calibration. The measured offset coefficient is placed in the offset register.
1	0	1	Reserved.
1	1	0	System Zero-Scale Calibration. Users should connect the system zero-scale input to the channel input pins. A system offset calibration takes two conversion cycles to complete. \overline{RDY} goes high when the calibration is initiated and returns low when the calibration is complete. The ADC is placed in idle mode following a calibration. The measured offset coefficient is placed in the offset register.
1	1	1	System Full-Scale Calibration. Users should connect the system full-scale input to the channel input pins. A calibration takes two conversion cycles to complete. \overline{RDY} goes high when the calibration is initiated and returns low when the calibration is complete. The ADC is placed in idle mode following a calibration. The measured full-scale coefficient is placed in the full-scale register.

Table 14. Update Rates Available

FS3	FS2	FS1	FS0	f_{ADC} (Hz)	t_{SETTLE} (ms)	Rejection @ 50 Hz/60 Hz (Internal Clock)
0	0	0	0	X	X	
0	0	0	1	X	X	
0	0	1	0	X	X	
0	0	1	1	123	16	
0	1	0	0	62	32	
0	1	0	1	50	40	
0	1	1	0	X	X	
0	1	1	1	33.2	60	
1	0	0	0	X	X	
1	0	0	1	16.7	120	80 dB (50 Hz only)
1	0	1	0	16.7	120	65 dB (50 Hz and 60 Hz)
1	0	1	1	12.5	160	66 dB (50 Hz and 60 Hz)
1	1	0	0	10	200	69 dB (50 Hz and 60 Hz)
1	1	0	1	8.33	240	70 dB (50 Hz and 60 Hz)
1	1	1	0	6.25	320	72 dB (50 Hz and 60 Hz)
1	1	1	1	4.17	480	74 dB (50 Hz and 60 Hz)

AD7796/AD7797

CONFIGURATION REGISTER

RS2, RS1, RS0 = 0, 1, 0; Power-On/Reset = 0x0710

The configuration register is a 16-bit read/write register. This register is used to configure the ADC for unipolar or bipolar mode, enable or disable the burnout currents, and select the analog input channel. Table 15 outlines the bit designations for the configuration register. CON0 through CON15 indicate the bit locations, with CON denoting that the bits are in the configuration register. CON15 denotes the first bit of the data stream. The number in brackets indicates the power-on/reset default status of that bit.

MSB														LSB	
CON15	CON14	CON13	CON12	CON11	CON10	CON9	CON8	CON7	CON6	CON5	CON4	CON3	CON2	CON1	CON0
0(0)	0(0)	BO(0)	U/B(0)	0(0)	1(1)	1(1)	1(1)	0(0)	0(0)	0(0)	1(1)	0(0)	CH2(0)	CH1(0)	CH0(0)

Table 15. Configuration Register Bit Designations

Bit Location	Bit Name	Description																																				
CON15 to CON14	0	These bits must be programmed with a Logic 0 for correct operation.																																				
CON13	BO	Burnout Current Enable Bit. When this bit is set to 1 by the user, the 100 nA current sources in the signal path are enabled. When BO = 0, the burnout currents are disabled.																																				
CON12	U/B	Unipolar/Bipolar Bit. Set by user to enable unipolar coding, that is, a zero differential input results in 0x0000(00) output, and a full-scale differential input results in 0xFFFF(FF) output. Cleared by the user to enable bipolar coding. A negative full-scale differential input results in an output code of 0x0000(00), a zero differential input results in an output code of 0x8000(00), and a positive full-scale differential input results in an output code of 0xFFFF(FF).																																				
CON11	0	This bit must be programmed with a Logic 0 for correct operation.																																				
CON10 to CON8	1	These bits must be programmed with a Logic 1 for correct operation.																																				
CON7 to CON5	0	These bits must be programmed with a Logic 0 for correct operation.																																				
CON4	1	This bit must be programmed with a Logic 1 for correct operation.																																				
CON3	0	This bit must be programmed with a Logic 0 for correct operation.																																				
CON2 to CON0	CH2 to CH0	Channel Select bits. Written by the user to select the active analog input channel to the ADC.																																				
		<table border="1"> <thead> <tr> <th>CH2</th> <th>CH1</th> <th>CH0</th> <th>Channel</th> </tr> </thead> <tbody> <tr> <td>0</td> <td>0</td> <td>0</td> <td>AIN(+) – AIN(–)</td> </tr> <tr> <td>0</td> <td>0</td> <td>1</td> <td>Reserved</td> </tr> <tr> <td>0</td> <td>1</td> <td>0</td> <td>Reserved</td> </tr> <tr> <td>0</td> <td>1</td> <td>1</td> <td>AIN(–) – AIN(–)</td> </tr> <tr> <td>1</td> <td>0</td> <td>0</td> <td>Reserved</td> </tr> <tr> <td>1</td> <td>0</td> <td>1</td> <td>Reserved</td> </tr> <tr> <td>1</td> <td>1</td> <td>0</td> <td>Temp Sensor</td> </tr> <tr> <td>1</td> <td>1</td> <td>1</td> <td>AV_{DD} Monitor</td> </tr> </tbody> </table>	CH2	CH1	CH0	Channel	0	0	0	AIN(+) – AIN(–)	0	0	1	Reserved	0	1	0	Reserved	0	1	1	AIN(–) – AIN(–)	1	0	0	Reserved	1	0	1	Reserved	1	1	0	Temp Sensor	1	1	1	AV _{DD} Monitor
CH2	CH1	CH0	Channel																																			
0	0	0	AIN(+) – AIN(–)																																			
0	0	1	Reserved																																			
0	1	0	Reserved																																			
0	1	1	AIN(–) – AIN(–)																																			
1	0	0	Reserved																																			
1	0	1	Reserved																																			
1	1	0	Temp Sensor																																			
1	1	1	AV _{DD} Monitor																																			

DATA REGISTER

RS2, RS1, RS0 = 0, 1, 1; Power-On/Reset = 0x0000 (AD7796)/0x000000 (AD7797)

The conversion result from the ADC is stored in this data register. This is a read-only register. On completion of a read operation from this register, the RDY bit/pin is set.

ID REGISTER

RS2, RS1, RS0 = 1, 0, 0; Power-On/Reset = 0x5A (AD7796)/0x5B (AD7797)

The identification number for the AD7796/AD7797 is stored in the ID register. This is a read-only register.

OFFSET REGISTER***RS2, RS1, RS0 = 1, 1, 0; Power-On/Reset = 0x8000 (AD7796)/0x800000 (AD7797)***

The analog input channel has an offset register that holds the offset calibration coefficient for the channel. This register is 16 bits wide on the AD7796 and 24 bits wide on the AD7797, and its power-on/reset value is 0x8000(00). The offset register is used in conjunction with the full-scale register to form a register pair. The power-on/reset value is automatically overwritten if an internal or system zero-scale calibration is initiated by the user. The offset register is a read/write register. However, the AD7796/AD7797 must be in idle mode or power-down mode when writing to this register.

FULL-SCALE REGISTER***RS2, RS1, RS0 = 1, 1, 1; Power-On/Reset = 0x5XXX (AD7796)/0x5XXX00 (AD7797)***

The full-scale register is a 16-bit register on the AD7796 and a 24-bit register on the AD7797. The full-scale register holds the full-scale calibration coefficient for the ADC. The full-scale register is a read/write register. However, when writing to the full-scale register, the ADC must be placed in power-down mode or idle mode. The full-scale register is configured on power-on with the factory-calibrated full-scale calibration coefficient. Therefore, every device has a different default coefficient. The default value is automatically overwritten if a system full-scale calibration is initiated by the user, or if the full-scale register is written to.

AD7796/AD7797

ADC CIRCUIT INFORMATION

OVERVIEW

The AD7796/AD7797 are low power ADCs that incorporate a Σ - Δ modulator, in-amp, and an on-chip digital filter intended for measuring wide dynamic range, low frequency signals, such as those in pressure transducers and weigh scales.

Each part has one differential input that is buffered. Figure 10 shows the basic connections required to operate the part.

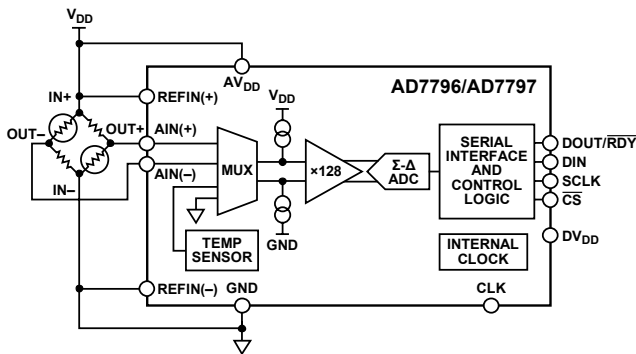

Figure 10. Basic Connection Diagram

The output rate of the AD7796/AD7797 (f_{ADC}) is user-programmable. The allowable update rates, along with the corresponding settling times, are listed in Table 14. Normal mode rejection is the major function of the digital filter. Simultaneous 50 Hz and 60 Hz rejection is optimized when the update rate equals 16.7 Hz or less because notches are placed at both 50 Hz and 60 Hz with these update rates (see Figure 12).

The AD7796/AD7797 use slightly different filter types, depending on the output update rate used to optimize the rejection of quantization noise and device noise. When the update rate is 4.17 Hz to 12.5 Hz, a Sinc^3 filter and an averaging filter are used. When the update rate is 16.7 Hz to 33.2 Hz, a modified Sinc^3 filter is used. This filter gives simultaneous 50 Hz/60 Hz rejection when the update rate equals 16.7 Hz. A Sinc^4 filter is used when the update rate is from 50 Hz to 123 Hz. Figure 11 to Figure 13 show the frequency response of the different filter types for some of the update rates.

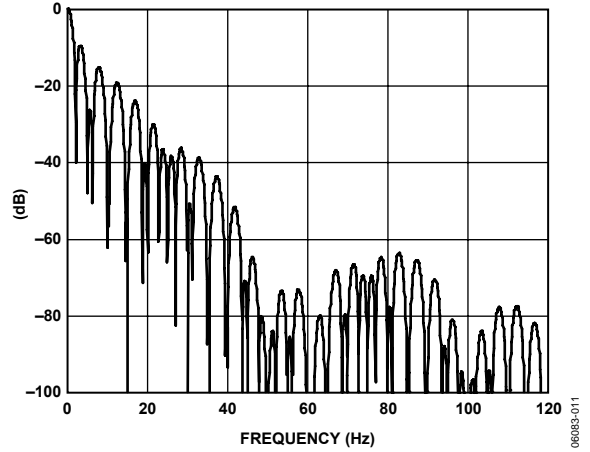

Figure 11. Filter Profile with Update Rate = 4.17 Hz

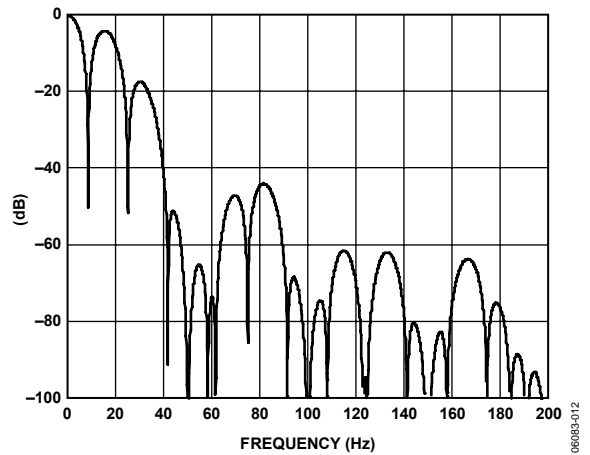

Figure 12. Filter Profile with Update Rate = 16.7 Hz

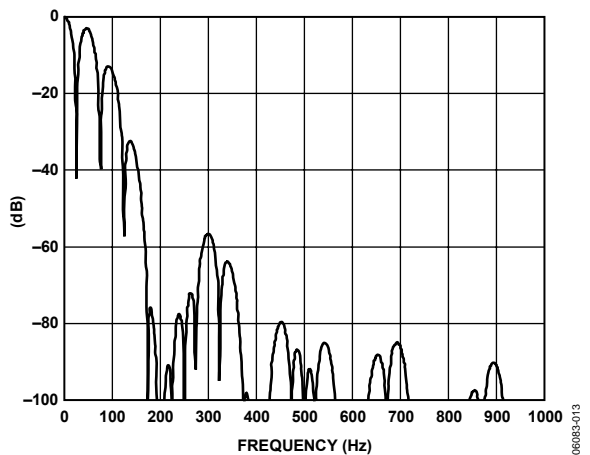

Figure 13. Filter Profile with Update Rate = 50 Hz

DIGITAL INTERFACE

As outlined in the On-Chip Registers section, the AD7796/AD7797 programmable functions are controlled by a set of on-chip registers. Data is written to these registers via the part's serial interface and read access to the on-chip registers is also provided by this interface. All communication with the part must start with a write to the communication register. After power-on or reset, the device expects a write to its communication register. The data written to this register determines whether the next operation is a read or a write operation, and determines the register where this operation occurs. Therefore, write access to any of the other registers on the part begins with a write operation to the communication register followed by a write to the selected register. A read operation from any other register (except when continuous read mode is selected) starts with a write to the communication register followed by a read operation from the selected register.

The serial interface of the AD7796/AD7797 consists of four signals: \overline{CS} , DIN, SCLK, and DOUT/ \overline{RDY} . The DIN line is used to transfer data into the on-chip registers, while DOUT/ \overline{RDY} is used for accessing from the on-chip registers. SCLK is the serial clock input for the device, and all data transfers (either on DIN or DOUT/ \overline{RDY}) occur with respect to the SCLK signal. The DOUT/ \overline{RDY} pin also operates as a data-ready signal, that is, the line goes low when a new data-word is available in the output register. It is reset high when a read operation from the data register is complete. DOUT/ \overline{RDY} also goes high prior to the data register update to indicate when not to read from the device. This ensures that a data read is not attempted while the register is being updated. \overline{CS} is used to select a device. It can be used to decode the AD7796/AD7797 in systems where several components are connected to the serial bus.

Figure 3 and Figure 4 show timing diagrams for interfacing to the AD7796/AD7797 with \overline{CS} being used to decode the part.

Figure 3 shows the timing for a read operation from the AD7796/AD7797 output shift register, while Figure 4 shows the timing for a write operation to the input shift register. It is possible to read the same word from the data register several times, even though the DOUT/ \overline{RDY} line returns high after the first read operation. However, care must be taken to ensure that the read operations have been completed before the next output update occurs. In continuous read mode, the data register can be read only once.

The serial interface can operate in 3-wire mode by tying \overline{CS} low. In this case, the SCLK, DIN, and DOUT/ \overline{RDY} lines are used to communicate with the AD7796/AD7797. The end of the conversion can be monitored using the \overline{RDY} bit in the status register. This scheme is suitable for interfacing to micro-controllers. If \overline{CS} is required as a decoding signal, it can be generated from a port pin. For microcontroller interfaces, it is recommended that SCLK idle high between data transfers.

The AD7796/AD7797 can be operated with \overline{CS} being used as a frame synchronization signal. This scheme is useful for DSP interfaces. In this case, the first bit (MSB) is effectively clocked out by \overline{CS} because \overline{CS} normally occurs after the falling edge of SCLK in DSPs. The SCLK can continue to run between data transfers, provided the timing numbers are obeyed.

The serial interface can be reset by writing a series of 1s on the DIN input. If a Logic 1 is written to the AD7796/AD7797 DIN line for at least 32 serial clock cycles, the serial interface is reset. This ensures that the interface can be reset to a known state if the interface gets lost due to a software error or glitch in the system. Reset returns the interface to the state where it is expecting a write to the communication register. This operation resets the contents of all registers to their power-on values. Following a reset, the user should allow a period of 500 μ s before addressing the serial interface.

The AD7796/AD7797 can be configured to continuously convert or to perform a single conversion. See Figure 14 through Figure 16.

AD7796/AD7797

Single Conversion Mode

In single conversion mode, the AD7796/AD7797 are placed in shutdown mode between conversions. When a single conversion is initiated by setting MD2, MD1, and MD0 in the mode register to 0, 0, and 1, respectively, the part powers up, performs a single conversion, and then returns to shutdown mode. The on-chip oscillator requires 1 ms to power-up. A conversion requires a time period of $2 \times t_{ADC}$. DOUT/RDY goes low to indicate the completion of a conversion. When the data-word has been read from the data register, DOUT/RDY goes high. If CS is low, DOUT/RDY remains high until another conversion is initiated and completed. The data register can be read several times, if required, even when DOUT/RDY has gone high.

Continuous Conversion Mode

This is the default power-up mode. The AD7796/AD7797 continuously convert, and the RDY pin in the status register goes low each time a conversion is complete. If CS is low, the DOUT/RDY line also goes low when a conversion is complete. To read a conversion, the user can write to the communication register, indicating that the next operation is a read of the data register. The digital conversion is placed on the DOUT/RDY pin as soon as SCLK pulses are applied to the ADC. DOUT/RDY returns high when the conversion is read. The user can read this register additional times, if required. However, the user must ensure that the data register is not being accessed at the completion of the next conversion, or the new conversion word is lost.

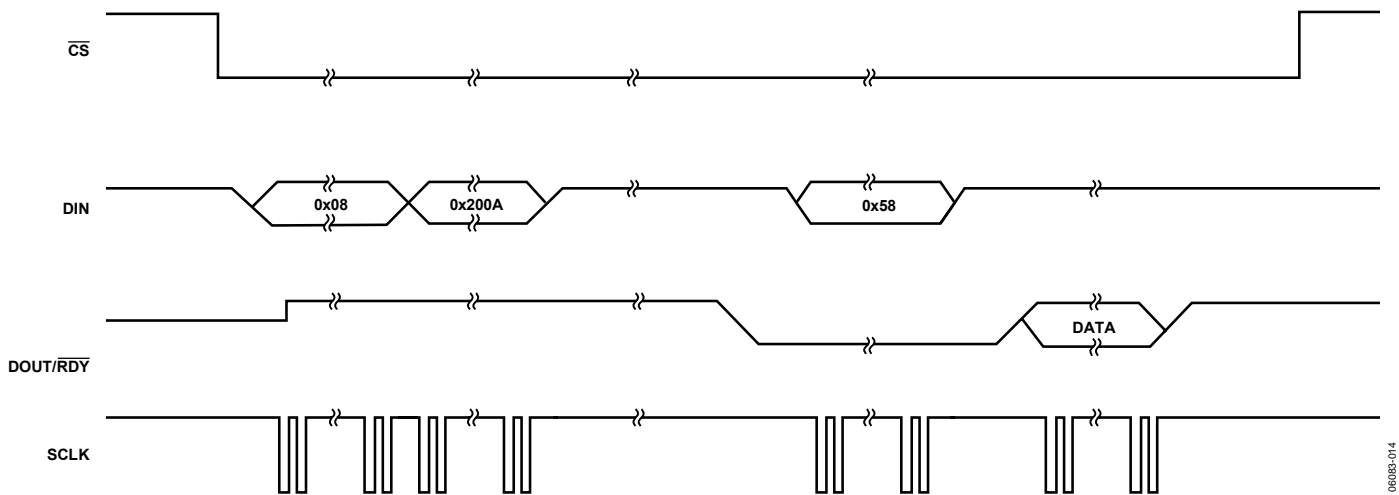

Figure 14. Single Conversion

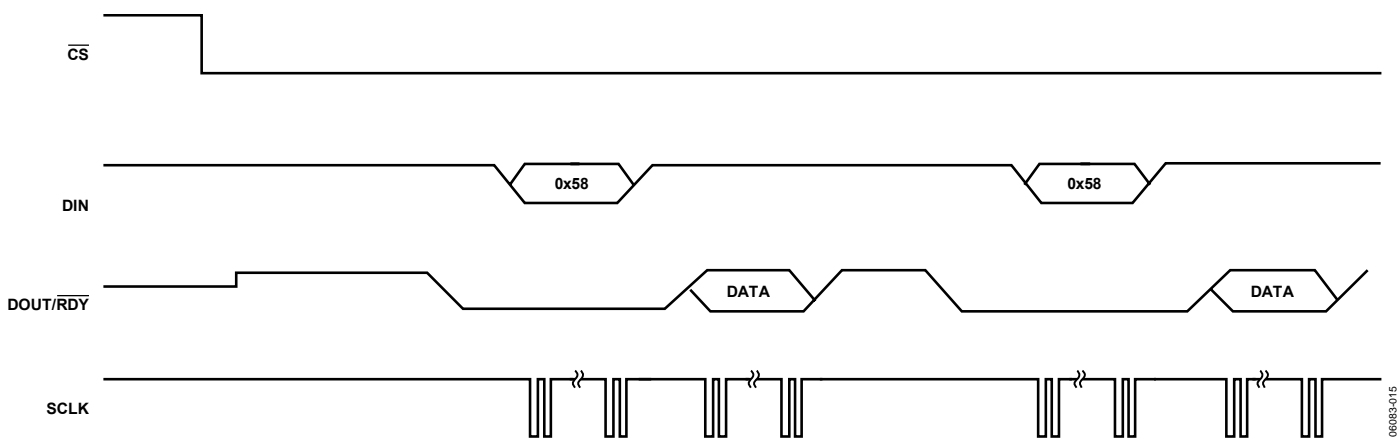

Figure 15. Continuous Conversion

Continuous Read Mode

Rather than write to the communication register each time a conversion is complete to access the data, the AD7796/AD7797 can be configured to automatically place the conversions on the DOUT/RDY line. By writing 01011100 to the communication register, the user need only apply the appropriate number of SCLK cycles to the ADC. The 16-/24-bit word is automatically placed on the DOUT/RDY line when a conversion is complete. The ADC should be configured for continuous conversion mode.

When DOUT/RDY goes low to indicate the end of a conversion, sufficient SCLK cycles must be applied to the ADC. The data conversion is placed on the DOUT/RDY line. When the conversion is read, DOUT/RDY returns high until the next conversion is available. In this mode, the data can be read only once.

The user must also ensure that the data-word is read before the next conversion is complete. If the user has not read the conversion before the completion of the next conversion, or if insufficient serial clocks are applied to the AD7796/AD7797 to read the word, the serial output register is reset when the next conversion is complete. The new conversion is placed in the output serial register.

To exit continuous read mode, the instruction 01011000 must be written to the communication register while the DOUT/RDY pin is low. While in continuous read mode, the ADC monitors activity on the DIN line to receive the instruction to exit the continuous read mode. Additionally, a reset occurs if 32 consecutive 1s are seen on DIN. Therefore, DIN should be held low in continuous read mode until an instruction is written to the device.

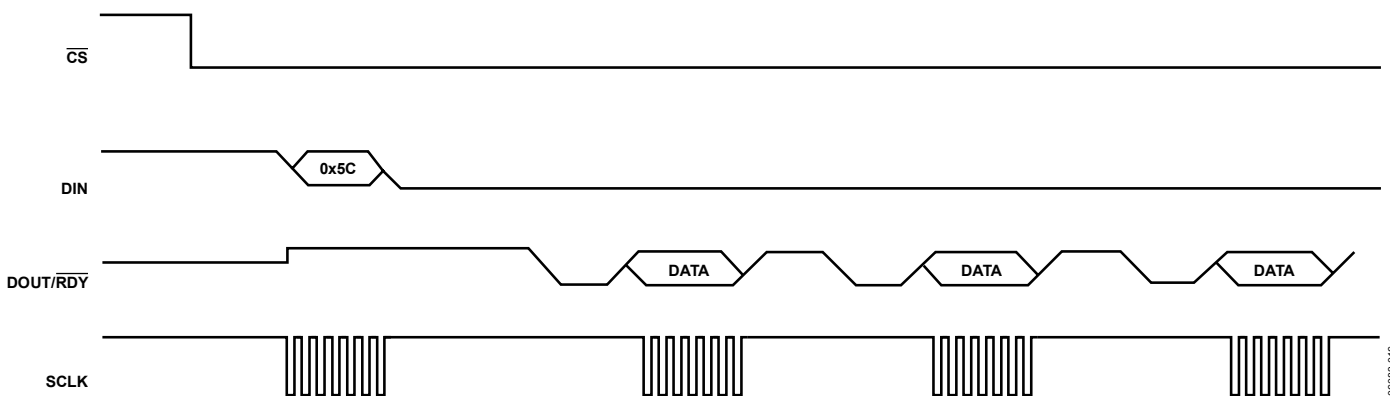

Figure 16. Continuous Read

AD7796/AD7797

CIRCUIT DESCRIPTION

ANALOG INPUT CHANNEL

The AD7796/AD7797 have one differential analog input channel. The input channel feeds into a high impedance input stage of the amplifier. Therefore, the input can tolerate significant source impedances and is tailored for direct connection to external resistive-type sensors such as strain gages.

The absolute input voltage range is restricted to a range between $GND + 300\text{ mV}$ and $AV_{DD} - 1.1\text{ V}$. Care must be taken in setting up the common-mode voltage to avoid exceeding these limits. Otherwise, there is degradation in linearity and noise performance.

This low noise in-amp means that signals of small amplitude can be gained within the AD7796/AD7797 while still maintaining excellent noise performance. The amplifier is configured to have a gain of 128. Therefore, with an external 2.5 V reference, the unipolar range is 0 mV to 20 mV while the bipolar range is $\pm 20\text{ mV}$. The common-mode voltage $((AIN(+)) + AIN(-))/2$ must be $\geq 0.5\text{ V}$.

BIPOLAR/UNIPOLAR CONFIGURATION

The analog input to the AD7796/AD7797 can accept either unipolar or bipolar input voltage ranges. A bipolar input range does not imply that the part can tolerate negative voltages with respect to system GND. Unipolar and bipolar signals on the $AIN(+)$ input are referenced to the voltage on the $AIN(-)$ input. For example, if $AIN(-)$ is 2.5 V and the ADC is configured for unipolar mode, the input voltage range on the $AIN(+)$ pin is 2.5 V to 2.02 V.

If the ADC is configured for bipolar mode, the analog input range on the $AIN(+)$ input is 2.48 V to 2.52 V. The bipolar/unipolar option is chosen by programming the U/B bit in the configuration register.

DATA OUTPUT CODING

When the ADC is configured for unipolar operation, the output code is natural (straight) binary with a zero differential input voltage resulting in a code of 00...00, a mid-scale voltage resulting in a code of 100...000, and a full-scale input voltage resulting in a code of 111...111. The output code for any analog input voltage can be represented as

$$Code = (2^N \times AIN \times 128) / V_{REF}$$

When the ADC is configured for bipolar operation, the output code is offset binary with a negative full-scale voltage resulting in a code of 000...000, a zero differential input voltage resulting in a code of 100...000, and a positive full-scale input voltage resulting in a code of 111...111. The output code for any analog input voltage can be represented as

$$Code = 2^{N-1} \times [(AIN \times 128 / V_{REF}) + 1]$$

where:

AIN is the analog input voltage

$N = 16/24$ for the AD7796/AD7797.

REFERENCE

The AD7796/AD7797 have a fully differential input capability for the channel. The common-mode range for these differential inputs is GND to AV_{DD} . The reference input is unbuffered; therefore, excessive R-C source impedances introduce gain errors. The reference voltage $REFIN$ ($REFIN(+)$ – $REFIN(-)$) is 2.5 V nominal, but the AD7796/AD7797 are functional with reference voltages 0.1 V to AV_{DD} . In applications where the excitation (voltage or current) for the transducer on the analog input also drives the reference voltage for the part, the effect of the low frequency noise in the excitation source is removed because the application is ratiometric. If the AD7796/AD7797 are used in a nonratiometric application, a low noise reference should be used.

Recommended 2.5 V reference voltage sources for the AD7796/AD7797 include the ADR381 and ADR391, which are low noise, low power references. Also note that the reference inputs provide a high impedance, dynamic load. Because the input impedance of each reference input is dynamic, resistor/capacitor combinations on these inputs can cause dc gain errors, depending on the output impedance of the source that is driving the reference inputs.

Reference voltage sources such as those recommended above (the ADR391, for example) typically have low output impedances and are, therefore, tolerant to decoupling capacitors on $REFIN(+)$ without introducing gain errors in the system. Deriving the reference input voltage across an external resistor means that the reference input sees a significant external source impedance. External decoupling on the $REFIN$ pins is not recommended in this type of circuit configuration.

RESET

The circuitry and serial interface of the AD7796/AD7797 can be reset by writing 32 consecutive 1s to the device. This resets the logic, the digital filter, and the analog modulator, while all on-chip registers are reset to their default values. A reset is automatically performed on power-up. When a reset is initiated, the user must allow a period of 500 μ s before accessing any of the on-chip registers. A reset is useful if the serial interface becomes asynchronous because of noise on the SCLK line.

BURNOUT CURRENTS

The AD7796/AD7797 contain two 100 nA constant current generators, one sourcing current from AV_{DD} to AIN(+) and one sinking current from AIN(–) to GND. Both currents are either on or off, depending on the burnout current enable (BO) bit in the configuration register. These currents can be used to verify that an external transducer is still operational before attempting to take measurements. When the burnout currents are turned on, they flow in the external transducer circuit, and a measurement of the input voltage on the analog input channel can be taken. If the resulting voltage is full scale, the user needs to verify why this is the case. A full-scale reading could mean that the front-end sensor is open circuit. It could also mean that the front-end sensor is overloaded and is justified in outputting full scale, or that the reference could be absent, thus clamping the data to all 1s.

When reading all 1s from the output, the user needs to check these three cases before making a judgment. If the voltage measured is 0 V, it could indicate that the transducer has short circuited. For normal operation, these burnout currents are turned off by writing a 0 to the BO bit in the configuration register.

AV_{DD} MONITOR

Along with converting external voltages, the ADC can be used to monitor the voltage on the AV_{DD} pin. When Bit CH2 to Bit CH0 equal 1, the voltage on the AV_{DD} pin is internally attenuated by 6. The resulting voltage is applied to the Σ - Δ modulator using an internal 1.17 V reference for analog-to-digital conversion. This is useful because variations in the power supply voltage can be monitored.

TEMPERATURE MONITOR

The AD7796/AD7797 have an embedded temperature sensor that is accessed when Bit CH2 to Bit CH0 are equal to 1, 1, 0, respectively. When the internal temperature sensor is selected, the AD7796/AD7797 use an internal 1.17 V reference for the conversions. The temperature sensor has a sensitivity of 0.81 mV/ $^{\circ}$ C. However, a two-point calibration is required to optimize the accuracy. The temperature sensor is not factory calibrated; a user calibration is required. Following a calibration, the accuracy is 2 $^{\circ}$ C.

CALIBRATION

The AD7796/AD7797 provide three calibration modes that can be programmed via the mode bits in the mode register. These are internal zero-scale calibration, system zero-scale calibration, and system full-scale calibration, which effectively reduces the offset error and full-scale error to the order of the noise. After each conversion, the ADC conversion result is scaled using the ADC calibration registers before being written to the data register. The offset calibration coefficient is subtracted from the result prior to multiplication by the full-scale coefficient.

To start a calibration, write the relevant value to the MD2 to MD0 bits in the mode register. $\overline{DOUT}/\overline{RDY}$ goes high when the calibration is initiated. After the calibration is complete, the contents of the corresponding calibration registers are updated, the \overline{RDY} bit in the status register is set, the $\overline{DOUT}/\overline{RDY}$ pin goes low (if \overline{CS} is low), and the AD7796/AD7797 revert to idle mode.

During an internal zero-scale calibration, the zero input is automatically connected internally to the ADC input pins. A system calibration, however, expects the system zero-scale and system full-scale voltages to be applied to the ADC pins before the calibration mode is initiated. In this way, external ADC errors are removed.

From an operational point of view, a calibration should be treated like another ADC conversion. A zero-scale calibration (if required) should always be performed before a full-scale calibration. System software should monitor the \overline{RDY} bit in the status register or the $\overline{DOUT}/\overline{RDY}$ pin to determine the end of calibration via a polling sequence or an interrupt-driven routine.

Both an internal offset calibration and system offset calibration takes two conversion cycles. An internal offset calibration is not needed because the ADC itself removes the offset continuously.

A system full-scale calibration takes two conversion cycles to complete. The measured full-scale coefficient is placed in the full-scale register. If system offset calibrations are being performed along with system full-scale calibrations, the offset calibration should be performed before the system full-scale calibration is initiated.

AD7796/AD7797

GROUNDING AND LAYOUT

Because the analog input and reference input of the ADC are differential, most of the voltages in the analog modulator are common-mode voltages. The excellent common-mode rejection of the part removes common-mode noise on these inputs. The digital filter provides rejection of broadband noise on the power supply, except at integer multiples of the modulator sampling frequency. The digital filter also removes noise from the analog and reference inputs provided that these noise sources do not saturate the analog modulator. As a result, the AD7796/AD7797 are more immune to noise interference than conventional high resolution converters. However, because the resolution of the AD7796/AD7797 is so high, and the noise levels from the AD7796/AD7797 are so low, care must be taken with regard to grounding and layout.

The printed circuit board that houses the AD7796/AD7797 should be designed such that the analog and digital sections are separated and confined to certain areas of the board. A minimum etch technique is generally best for ground planes because it gives the best shielding.

It is recommended that the GND pins of the AD7796/AD7797 be tied to the AGND plane of the system. In any layout, it is important that the user pay attention to the flow of currents in the system, and ensure that the return paths for all currents are as close as possible to the paths the currents took to reach their destinations. Avoid forcing digital currents to flow through the AGND sections of the layout.

The ground planes of the AD7796/AD7797 should be allowed to run under the AD7796/AD7797 to prevent noise coupling. The power supply lines to the AD7796/AD7797 should use as wide a trace as possible to provide low impedance paths and reduce the effects of glitches on the power supply line. Fast switching signals such as clocks should be shielded with digital ground to avoid radiating noise to other sections of the board, and clock signals should never be run near the analog inputs. Avoid crossover of digital and analog signals. Traces on opposite sides of the board should run at right angles to each other. This reduces the effects of feedthrough through the board. A micro-strip technique is by far the best, but it is not always possible with a double-sided board. In this technique, the component side of the board is dedicated to ground planes, while signals are placed on the solder side.

Good decoupling is important when using high resolution ADCs. AV_{DD} should be decoupled with 10 μF tantalum in parallel with 0.1 μF capacitors to GND. DV_{DD} should be decoupled with 10 μF tantalum in parallel with 0.1 μF capacitors to the system's DGND plane, with the system's AGND to DGND connection being close to the AD7796/AD7797. To achieve the best results from these decoupling components, they should be placed as close as possible to the device, ideally right up against the device. All logic chips should be decoupled with 0.1 μF ceramic capacitors to DGND.

APPLICATIONS

The AD7796/AD7797 offer a high resolution analog-to-digital function. Because the analog-to-digital function is provided by a Σ - Δ architecture, the parts are more immune to noisy environments, making them ideal for use in sensor measurement, and industrial and process-control applications.

WEIGH SCALES

Figure 17 shows the AD7796/AD7797 being used in a weigh scale application. The load cell is arranged in a bridge network and gives a differential output voltage between its OUT+ and OUT- terminals. Assuming a 5 V excitation voltage, the full-

scale output range from the transducer is 10 mV when the sensitivity is 2 mV/V. The excitation voltage for the bridge can be used to directly provide the reference for the ADC because the reference input range includes the supply voltage. This allows a ratiometric measurement. Therefore, variations of the excitation voltage do not affect the measurement.

The on-chip temperature sensor can be used for temperature compensation of the bridge so the variation of the sensor resistance with temperature drift can be monitored and the conversions from the bridge can be compensated.

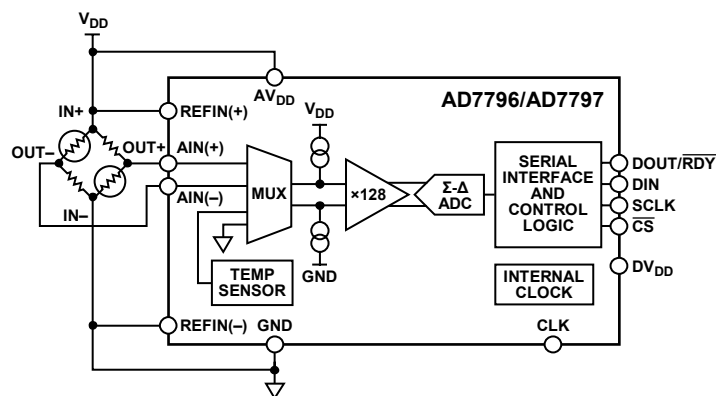
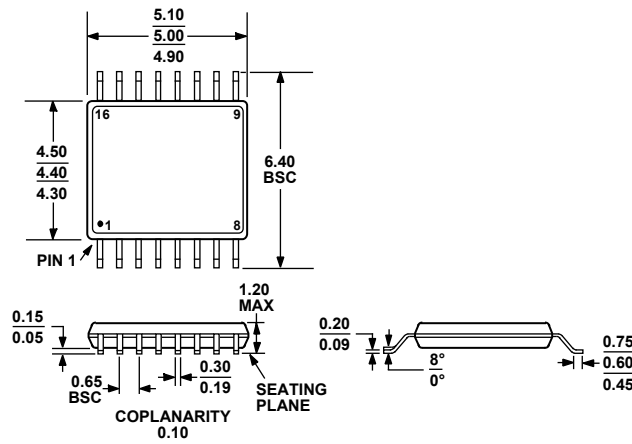

Figure 17. Weigh Scales Using the AD7796/AD7797

06085-017

AD7796/AD7797

OUTLINE DIMENSIONS



COMPLIANT TO JEDEC STANDARDS MO-153-AB

Figure 18. 16-Lead Thin Shrink Small Outline Package [TSSOP] (RU-16)

Dimensions shown in millimeters

ORDERING GUIDE

Model	Temperature Range	Package Description	Package Option
AD7796BRUZ ¹	-40°C to +85°C	16-Lead TSSOP	RU-16
AD7796BRUZ-REEL ¹	-40°C to +85°C	16-Lead TSSOP	RU-16
AD7797BRUZ ¹	-40°C to +85°C	16-Lead TSSOP	RU-16
AD7797BRUZ-REEL ¹	-40°C to +85°C	16-Lead TSSOP	RU-16
EVAL-AD7796EB		Evaluation Board	
EVAL-AD7797EB		Evaluation Board	

¹ Z = Pb-free part.