



## Series 77 Shrink Boots Straight Lipped Adapter Boots, Short How To Order

### Lipped Straight Shrink Boots, Short



Short straight boots with lip for attachment to standard circular connector adapters. These short boots are used where clearance is limited. After shrinking, the boot lip locks into adapter groove. Eyelet hole allows attachment of dust caps or protective covers. Choose Type 1 high performance elastomer for extreme temperatures and excellent resistance to fuels and oils, Type 2 non-halogenated flame-retardant polyolefin for use where limited fire hazard is required, or choose Type 3 general purpose polyolefin for use where occasional exposure to heat and chemicals may occur. Choose boot size based on adapter diameter and cable diameter.

**Table 1: Boot Size Selection Guide**

Boot Size	Adapter Diameter				Min. Cable Diameter	
	Inches		Millimeters		In.	mm.
	Min	Max	Min	Max		
03	.450	.850	11.43	21.59	.225	5.72
04	.600	1.000	15.24	25.40	.275	6.99
05	.750	1.200	19.05	30.48	.300	7.62
06	.900	1.350	22.86	34.29	.375	9.53
07	1.250	1.650	31.75	41.91	.425	10.80
08	1.400	2.250	35.56	57.15	.625	15.88
09	1.870	2.470	47.50	62.70	.660	16.80

**Table 2: Material Selection Guide**

Attribute	Type 1 High Performance Semi-Rigid Elastomer	Type 2 Zero Halogen Semi-Rigid Polyolefin	Type 3 General Purpose Flexible Polyolefin
Continuous Operating Temperature	-75° to +150°C	-30° to +125°C	-55° to +135°C
Resistance to Fuels, Oils, and Fluids	Excellent	Very Good	Good
Low Toxicity, Zero Halogen	No	Yes	No

**Table 3: Pre-Coated Boots Adhesive Information**

Attribute	W2 Standard Hot Melt Adhesive	W1 High Temperature Hot Melt Adhesive	R High Performance Epoxy Adhesive
Boot Material Compatibility	Types 1, 2 and 3	Types 1, 2 and 3	Type 1
Continuous Operating Temp.	-40° to +80°C	-55° to +105°C	-75° to +150°C
Resistance to Fuels, Oils, and Fluids	Good	Good	Excellent
Low Toxicity, Zero Halogen	Yes	Yes	Yes

### Lipped Straight Shrink Boots, Short- Type 1 High Performance Elastomer

- -75° C to +150° C
- Excellent resistance to fuels, oils, solvents and heat.

Semi-rigid high performance boots combine excellent resistance to fuels, oils and solvents with superior performance at extreme temperatures. Rated for 3000 hours continuous operation at +150° C, these boots fit most standard boot adapters for circular connectors. Material meets the requirements of VG95343 Type 6, BSG 198-5-DE, EN62329-102 and SAE AS5258 Type H. These boots are recommended for demanding applications such as military vehicles and petrochemical exploration.

#### Short Lipped Boot Part Numbers

Boot Size	Part Number with Eyelet				Part Number without Eyelet			
	No Adhesive Lining	Pre-Coated with W1 Hi-Temp Hot-Melt Adhesive	Pre-Coated with W2 Standard Hot-Melt Adhesive	Pre-Coated with R Epoxy Adhesive	No Adhesive Lining	Pre-Coated with W1 Hi-Temp Hot-Melt Adhesive	Pre-Coated with W2 Standard Hot-Melt Adhesive	Pre-Coated with R Epoxy Adhesive
03	770-002S103	770-002S103W1	770-002S103W2	770-002S103R	770-004S103	770-004S103W1	770-004S103W2	770-004S103R
04	770-002S104	770-002S104W1	770-002S104W2	770-002S104R	770-004S104	770-004S104W1	770-004S104W2	770-004S104R
05	770-002S105	770-002S105W1	770-002S105W2	770-002S105R	770-004S105	770-004S105W1	770-004S105W2	770-004S105R
06	770-002S106	770-002S106W1	770-002S106W2	770-002S106R	770-004S106	770-004S106W1	770-004S106W2	770-004S106R
07	770-002S107	770-002S107W1	770-002S107W2	770-002S107R	770-004S107	770-004S107W1	770-004S107W2	770-004S107R
08	770-002S108	770-002S108W1	770-002S108W2	770-002S108R	770-004S108	770-004S108W1	770-004S108W2	770-004S108R
09	770-002S109	770-002W109W1	770-002S109W2	770-002S109R	770-004S109	770-004S109W1	770-004S109W2	770-004S109R

Dimensions in inches (millimeters) and are subject to change without notice.

© 2011 Glenair, Inc.

CAGE Code 06324

Printed in U.S.A.

GLENAIR, INC. • 1211 AIR WAY • GLENDALE, CA 91201-2497 • 818-247-6000 • FAX 818-500-9912

www.glenair.com

12

E-Mail: sales@glenair.com

Rev. 24-AUGUST-2010

## Series 77 Shrink Boots Straight Lipped Adapter Boots, Short How To Order



### Lipped Straight Shrink Boots, Short- Type 2 Zero Halogen

- *Low Smoke, Zero Halogen*
- *-30° C to +125° C*



Halogen-free semi-flexible polyolefin boots meet low smoke and toxicity requirements of shipboard, transit and aircraft systems. These Low Smoke/Zero Halogen (LSZH) boots fit most standard shrink boot adapters, including M85049 types along with Glenair Series 31 and Series 44 adapters. Oxygen index greater than 30%, smoke index less than 20, and toxicity index under 3 per 100 grams. Material meets requirements of NAVSEA 5617649, VG95343 Part 29, BSG 198-5-DF, EN62329-101 and SAE AS5258 Type G. Good resistance to oils, fuels and solvents. Available with high temperature hot melt adhesive lining, these boots provide strain relief and environmental protection to connector/cable transitions. Temperature rating -30° to +125° C. Black color.

Boot Size	Part Number with Eyelet			Part Number without Eyelet		
	No Adhesive Lining	Pre-Coated with W1 Hi-Temp Hot-Melt Adhesive	Pre-Coated with W2 Standard Hot-Melt Adhesive	No Adhesive Lining	Pre-Coated with W1 Hi-Temp Hot-Melt Adhesive	Pre-Coated with W2 Standard Hot-Melt Adhesive
03	<a href="#">770-002S203</a>	<a href="#">770-002S203W1</a>	<a href="#">770-002S203W2</a>	<a href="#">770-004S203</a>	<a href="#">770-004S203W1</a>	<a href="#">770-004S203W2</a>
04	<a href="#">770-002S204</a>	<a href="#">770-002S204W1</a>	<a href="#">770-002S204W2</a>	<a href="#">770-004S204</a>	<a href="#">770-004S204W1</a>	<a href="#">770-004S204W2</a>
05	<a href="#">770-002S205</a>	<a href="#">770-002S205W1</a>	<a href="#">770-002S205W2</a>	<a href="#">770-004S205</a>	<a href="#">770-004S205W1</a>	<a href="#">770-004S205W2</a>
06	<a href="#">770-002S206</a>	<a href="#">770-002S206W1</a>	<a href="#">770-002S206W2</a>	<a href="#">770-004S206</a>	<a href="#">770-004S206W1</a>	<a href="#">770-004S206W2</a>
07	<a href="#">770-002S207</a>	<a href="#">770-002S207W1</a>	<a href="#">770-002S207W2</a>	<a href="#">770-004S207</a>	<a href="#">770-004S207W1</a>	<a href="#">770-004S207W2</a>
08	<a href="#">770-002S208</a>	<a href="#">770-002S208W1</a>	<a href="#">770-002S208W2</a>	<a href="#">770-004S208</a>	<a href="#">770-004S208W1</a>	<a href="#">770-004S208W2</a>
09	<a href="#">770-002S209</a>	<a href="#">770-002S209W1</a>	<a href="#">770-002S209W2</a>	<a href="#">770-004S209</a>	<a href="#">770-004S209W1</a>	<a href="#">770-004S209W2</a>

### Lipped Straight Shrink Boots, Short- Type 3 Polyolefin, Flexible

- *General purpose harnessing*
- *Economical, flexible*
- *-55° C to +135° C*

Economical flexible polyolefin boots fit standard shrink boot adapters, Glenair Series 31 and Series 44 adapters. These self-extinguishing boots meet the requirements of SAE AS81765/1 Type II. Good resistance to oils and fuels. Available with optional hot melt adhesive lining, these boots provide strain relief and environmental protection to connector/cable transitions. Temperature rating -55° to +135° C. Black color.

Boot Size	Part Number with Eyelet			Part Number without Eyelet		
	No Adhesive Lining	Pre-Coated with W2 Standard Hot-Melt Adhesive	Pre-Coated with W1 Hi-Temp Hot-Melt Adhesive	No Adhesive Lining	Pre-Coated with W2 Hot-Melt Adhesive	Pre-Coated with W1 Hi-Temp Hot-Melt Adhesive
03	<a href="#">770-002S303</a>	<a href="#">770-002S303W2</a>	<a href="#">770-002S303W1</a>	<a href="#">770-004S303</a>	<a href="#">770-004S303W2</a>	<a href="#">770-004S303W1</a>
04	<a href="#">770-002S304</a>	<a href="#">770-002S304W2</a>	<a href="#">770-002S304W1</a>	<a href="#">770-004S304</a>	<a href="#">770-004S304W2</a>	<a href="#">770-004S304W1</a>
05	<a href="#">770-002S305</a>	<a href="#">770-002S305W2</a>	<a href="#">770-002S305W1</a>	<a href="#">770-004S305</a>	<a href="#">770-004S305W2</a>	<a href="#">770-004S305W1</a>
06	<a href="#">770-002S306</a>	<a href="#">770-002S306W2</a>	<a href="#">770-002S306W1</a>	<a href="#">770-004S306</a>	<a href="#">770-004S306W2</a>	<a href="#">770-004S306W1</a>
07	<a href="#">770-002S307</a>	<a href="#">770-002S307W2</a>	<a href="#">770-002S307W1</a>	<a href="#">770-004S307</a>	<a href="#">770-004S307W2</a>	<a href="#">770-004S307W1</a>
08	<a href="#">770-002S308</a>	<a href="#">770-002S308W2</a>	<a href="#">770-002S308W1</a>	<a href="#">770-004S308</a>	<a href="#">770-004S308W2</a>	<a href="#">770-004S308W1</a>
09	<a href="#">770-002S309</a>	<a href="#">770-002S309W2</a>	<a href="#">770-002S309W1</a>	<a href="#">770-004S309</a>	<a href="#">770-004S309W2</a>	<a href="#">770-004S309W1</a>

### Lipped Straight Shrink Boots, Short- Dimensions

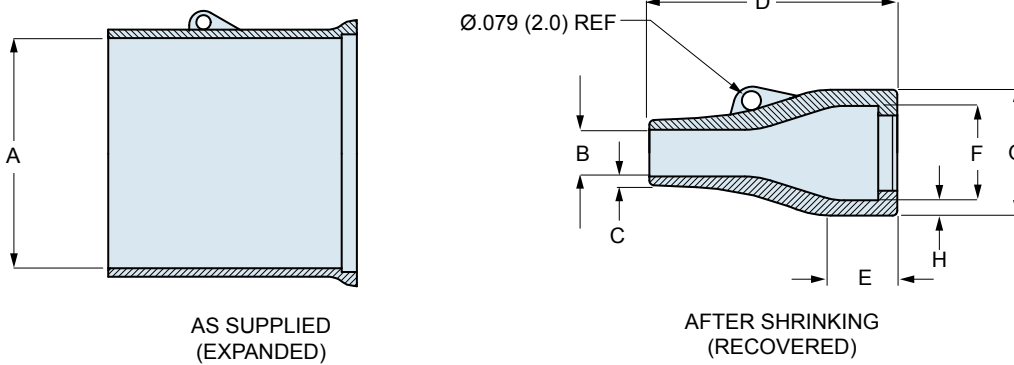

Boot Size	A Min.		B Max.		C ± 20%		D ± 10%		E Ref.		F Max.		G Ref.		H ± 30%	
	In.	mm.	In.	mm.	In.	mm.	In.	mm.	In.	mm.	In.	mm.	In.	mm.	In.	mm.
03	.945	24.0	.197	5.0	.035	0.9	1.024	26.0	.276	7.0	.413	10.5	.539	13.7	.063	1.6
04	1.181	30.0	.236	6.0	.039	1.0	1.693	43.0	.709	18.0	.551	14.0	.693	17.6	.071	1.8
05	1.260	32.0	.276	7.0	.047	1.2	1.850	47.0	.512	13.0	.709	18.0	.850	21.6	.071	1.8
06	1.417	36.0	.335	8.5	.047	1.2	2.362	60.0	.787	20.0	.866	22.0	1.024	26.0	.079	2.0
07	1.693	43.0	.394	10.0	.051	1.3	3.150	80.0	1.417	36.0	1.102	28.0	1.276	32.4	.087	2.2
08	2.362	60.0	.591	15.0	.063	1.6	4.331	110.0	1.181	30.0	1.378	35.0	1.638	41.6	.130	3.3
09	2.599	66.0	.661	16.8	.079	2.0	5.910	150.0	2.760	70.0	1.752	44.5	2.052	52.1	.150	3.8

### Lipped Straight Shrink Boots, Short- Part Marking, Raised Lettering

