

THIS COPY IS PROVIDED ON A RESTRICTED BASIS AND IS NOT TO BE USED IN ANY WAY DETRIMENTAL TO THE INTERESTS OF PANDUIT CORP.

PANDUIT PART #	STUD SIZE	DIMENSIONS - in. [mm]				
		A ± .02 [0,5]	W ± .01 [0,3]	C ± .02 [0,5]	M ± .02 [0,5]	H ± .01 [0,3]
P10-6RHT6	#6	.78 [19,81]	.31 [7,87]	.35 [8,89]	.62 [15,75]	.15 [3,81]
P10-8RHT6	#8	.78 [19,81]	.31 [7,87]	.35 [8,89]	.62 [15,75]	.17 [4,32]
P10-10RHT6	#10	.81 [20,57]	.38 [9,65]	.33 [8,38]	.62 [15,75]	.20 [5,08]
P10-14RHT6	1/4"	.96 [24,38]	.53 [13,46]	.42 [10,67]	.70 [17,78]	.27 [6,86]

UL TOOLS
CT-100A
CT-200
CT-600-A (CT-570CH)
CT-1570
CT-1701 (P10)
CT-2500 (CT-2570CH)

PANDUIT APPROVED TOOLS
CT-160
CT-260

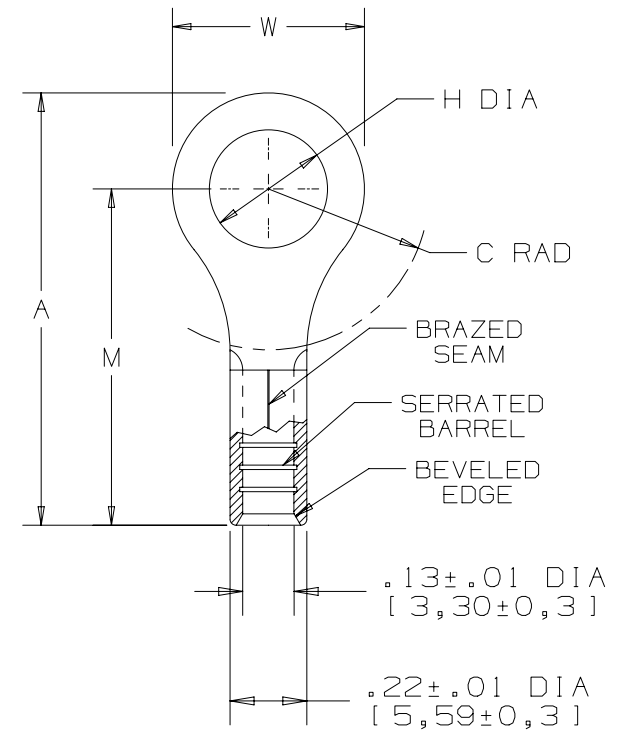

NOTES:

- UL LISTED FOR:
  - A. #14-10 AWG SOLID OR STRANDED COPPER WIRE
  - B. 650°F [343°C] MAX TEMP RATING
  - C. 2000 VOLTS MAX
- MATERIAL:
  - A. STAMPING - .04" [1,02] THK COPPER, NICKEL PLATED
- SEE [www.panduit.com](http://www.panduit.com) FOR PACKAGE QUANTITIES
- DIMENSIONS IN BRACKETS ARE IN MILLIMETERS
- WIRE STRIP LENGTH:  $9/32" \begin{matrix} +1/32 \\ -0 \end{matrix} [7,1mm \begin{matrix} +0,8 \\ -0 \end{matrix}]$



TITLE		<b>#14-10 BARREL NON INSULATED RING TONGUE, HIGH TEMPERATURE, 650° F</b>	
		CUSTOMER DRAWING	
ITEM REVISION NAME		N41267BA/03	
DATASET FILE NAME		N41267BA/03	
UNLESS OTHERWISE SPECIFIED, DIMENSIONAL TOLERANCES ARE: IN [mm]		MATERIAL:	
.X ±		.XXX ±	
.XX ±		ANGLES ±	
THIRD ANGLE PROJECTION		DRAWING NUMBER:	
A		A41267	
DRAWN BY	DATE	CHK	SCALE
EJD			N/A
DESCRIPTION		SHT 1 OF 1	
ECN		SIZE	
		A	

REV	DATE	BY	CHK	APR	DESCRIPTION	ECN
03	5/17	JHNU	TMR	RGB	UPDATED TOOL CHART FORMAT	N41267BA-DC
02	1/15	JHNU	TMR	RGB	ADDED cULus LOGO REVISED TITLE BLOCK	N41267BA-DC

D10100DA/16