

受 控

# SPECIFICATION

Customer : QUARTZ

Applied To :

Product Name : Receiver



Model Name : KPDR300TH-6437

Drawing No. : KFC6437

Signature of Approval

--

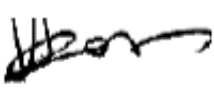
Signature of KEPO

Approved by	Checked by	Issued by	Date
			

宁波凯普电子有限公司



Ningbo Kepo Electronics Co.,Ltd.

宁波东钱湖镇东钱湖工业区宝源路 25 号

TEL:+86-574-88370330 FAX:+86-574-88370329

No.25 Baoyuan road Dongqian Lake, Industry Area, Dongqian town, Ningbo City, China(Post Code:315121)

[Sales@chinaacoustic.com](mailto:Sales@chinaacoustic.com)

[www.chinaacoustic.com](http://www.chinaacoustic.com)

Specification for Receiver	Page	2/9
Model No. : KPDR300TH-6437	Revision No.	1.0
	Drawing No.	KFC6437

## CONTENTS

1. Scope
2. General
3. Electrical and Acoustic Characteristics.
4. Reliability Test
  - 5.1. Measurement Block Diagram
  - 5.2. Response curve
- 6.1 HAC Measurement Block Diagram
- 6.2 HAC Response curve
7. Structure
8. Packing
9. Revision

Specification for Receiver		Page	3/9
		Revision No.	1.0
Model No. : KPDR300TH-6437	Drawing No.		KFC643

## 1. Scope

This specification covers a dynamic receiver unit KPDR300TH-6437 for phone use

## 2. General

- 2.1 Out-Diameter : Ø 35mm
- 2.2 Height : 17.5mm
- 2.3 Weight : 32gr.
- 2.4 Operating Temperature range:  
-20~+60°C without loss of function
- 2.5 Store Temperature range:  
-25~+65°C without loss of function

## 3. Electrical and Acoustic Characteristics.

Test condition : 20±2 °C, 60% ~ 70% RH, 860~1060 mbar

	Items	Specification
1	Impedance	300 Ω ± 20%(at 1Vrms,1kHz)
2	Sound Pressure Level	95dB ± 2dB( 1kHz/60mV with IEC 318coupler )
3	Frequency Range	300Hz~4KHz
4	Input Power	Rated 10mW / Max. 30mW
5	Buzz and Rattle	Should not be audible buzzes,rattles when the 10mw sine wave signal swept at frequency range.
6	Magnetic Field Intensity	Axial:-55dB 60mV at 1KHz

Specification for Receiver		Page	4/9
Model No. : KPDR300TH-6437		Revision No.	1.0
		Drawing No.	KFC647

## 4. Reliability Test

After test(1~7item), the speaker S.P.L . difference shall be within  $\pm 2\text{dB}$ , and the appearance not exist any change to be harmful to normal operation(e.g. cracks,rusts,damages and especially distortion).

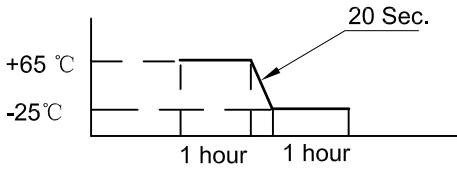
	Item	Specification
1	High Temperature Test	After being placed in a chamber with $+65\pm 3\text{ }^{\circ}\text{C}$ for 96 hours and then being placed in natural condition for 1 hour, speaker shall be measured.
2	Low Temperature Test	After being placed in a chamber with $-25\pm 3\text{ }^{\circ}\text{C}$ for 96 hours and then being placed in natural condition for 1 hour, speaker shall be measured.
3	Humidity Test	After being placed in a chamber with 90%R.H. at $+40\pm 2\text{ }^{\circ}\text{C}$ for 96 hours and then being placed in natural condition for 1 hour, speaker shall be measured.
4	Thermal Shock Test	<p>After being placed in a chamber at <math>+65\text{ }^{\circ}\text{C}</math> for 2 hour, then speaker shall be placed in a chamber at <math>-25\text{ }^{\circ}\text{C}</math> for 2 hour(1 cycle is the below diagram).</p> <p>After 2 above cycles, speaker shall be measured after being placed in natural condition for 1 hour.</p>  <p>The diagram shows a temperature profile starting at <math>+65\text{ }^{\circ}\text{C}</math> for a 1-hour dwell. It then ramps down to <math>-25\text{ }^{\circ}\text{C}</math> over a 20-second period. At <math>-25\text{ }^{\circ}\text{C}</math>, there is another 1-hour dwell. The cycle then repeats.</p>
5	Vibration Test	After being applied vibration of amplitude of 1.5mm with 10 to 55Hz band of vibration frequency to each of 3 perpendicular directions for 1 hour, then placed in natural condition for 2 hours each axes, speaker shall be measured.
6	Drop Test	Drop a unit contained in normal box into a board 5mm . (3 Place each 1 time)from a height of 1.5m and then a unit must have no abnormality
7	Load test	The receiver after being applied loading white noise with input power (30mw) for 24 hours, then placed in natural condition for 1 hour, speaker shall be measured.
8	Insulation test	When they are measured with DC 100V the insulation resistance between v.c. terminal and frame must be more than 1 $\text{M}\Omega$

Specification for Receiver		Page	5/9
		Revision No.	1.0
Model No. : KPDR300TH-6437	Drawing No.		KFC6437

## 5. Measurement Block Diagram & Response curve

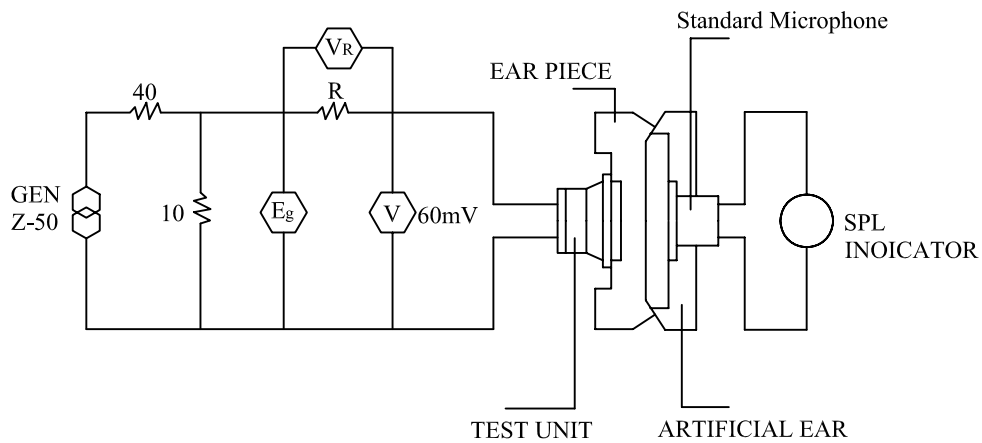

EAR PIECE

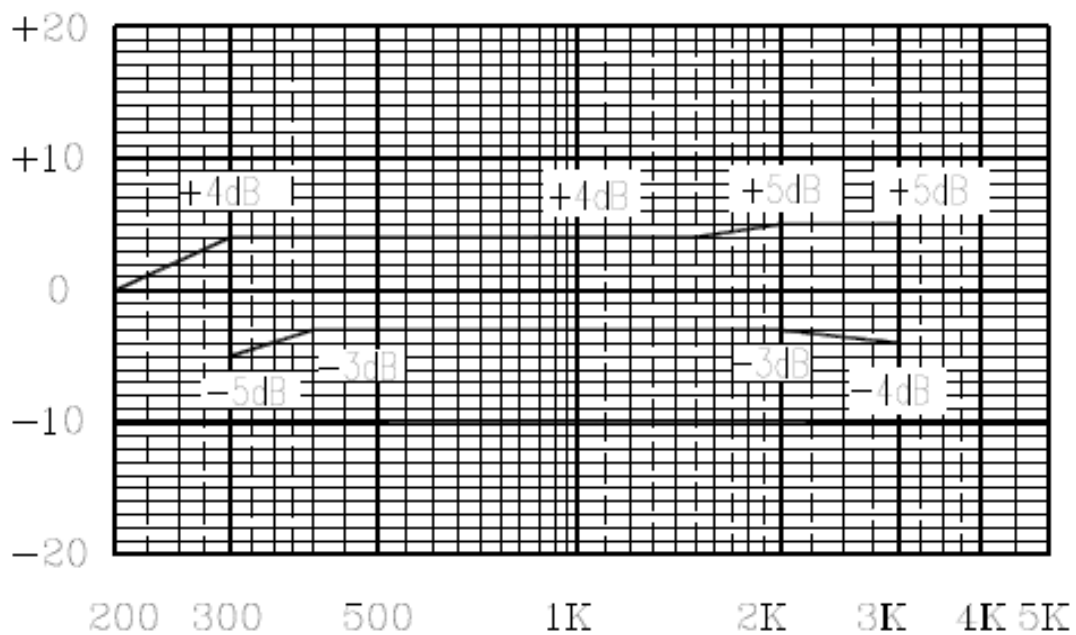
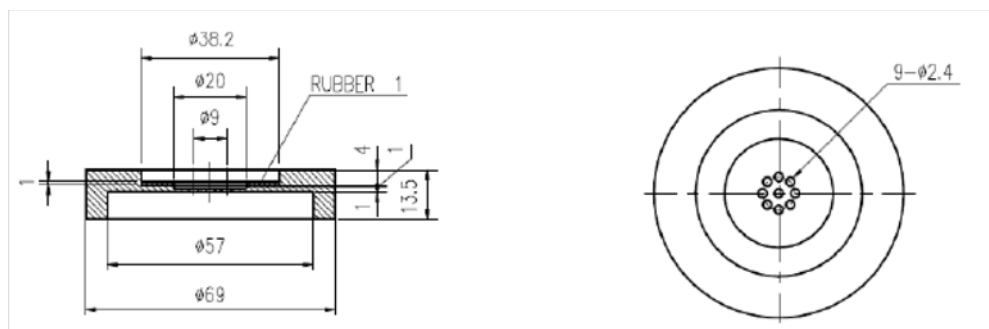

Specification for Receiver		Page	6/9
		Revision No.	1.0
Model No. : KPDR300TH-6437	Drawing No.		KFC6437

## 6.1 HAC Measurement Block Diagram

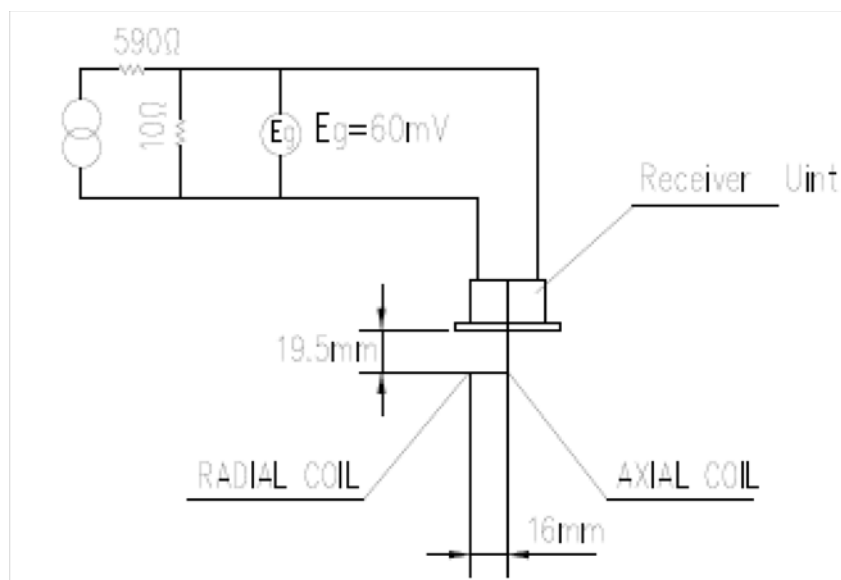

## 6.2 HAC Response curve

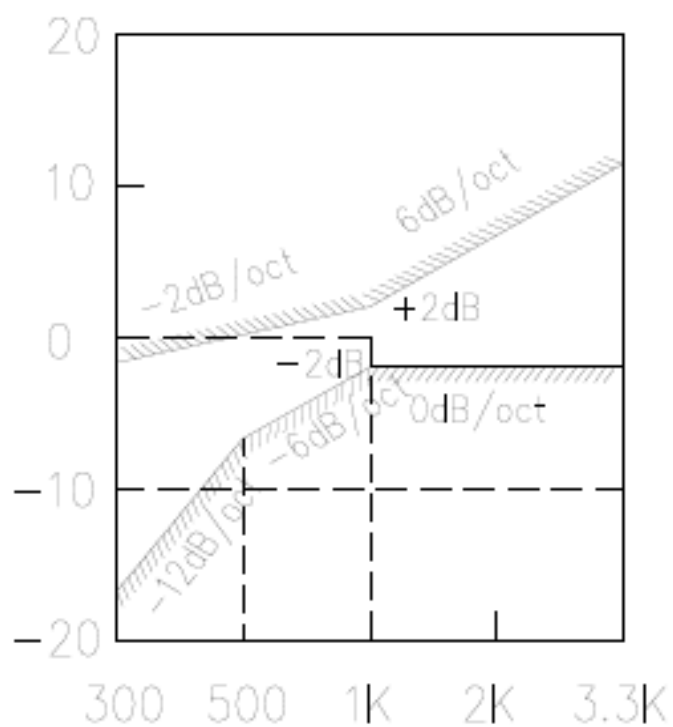

Specification for Receiver	Page	7/9
	Revision No.	1.0
Model No. : KPDR300TH-6437	Drawing No.	KFC6437

## 7. Dimensions

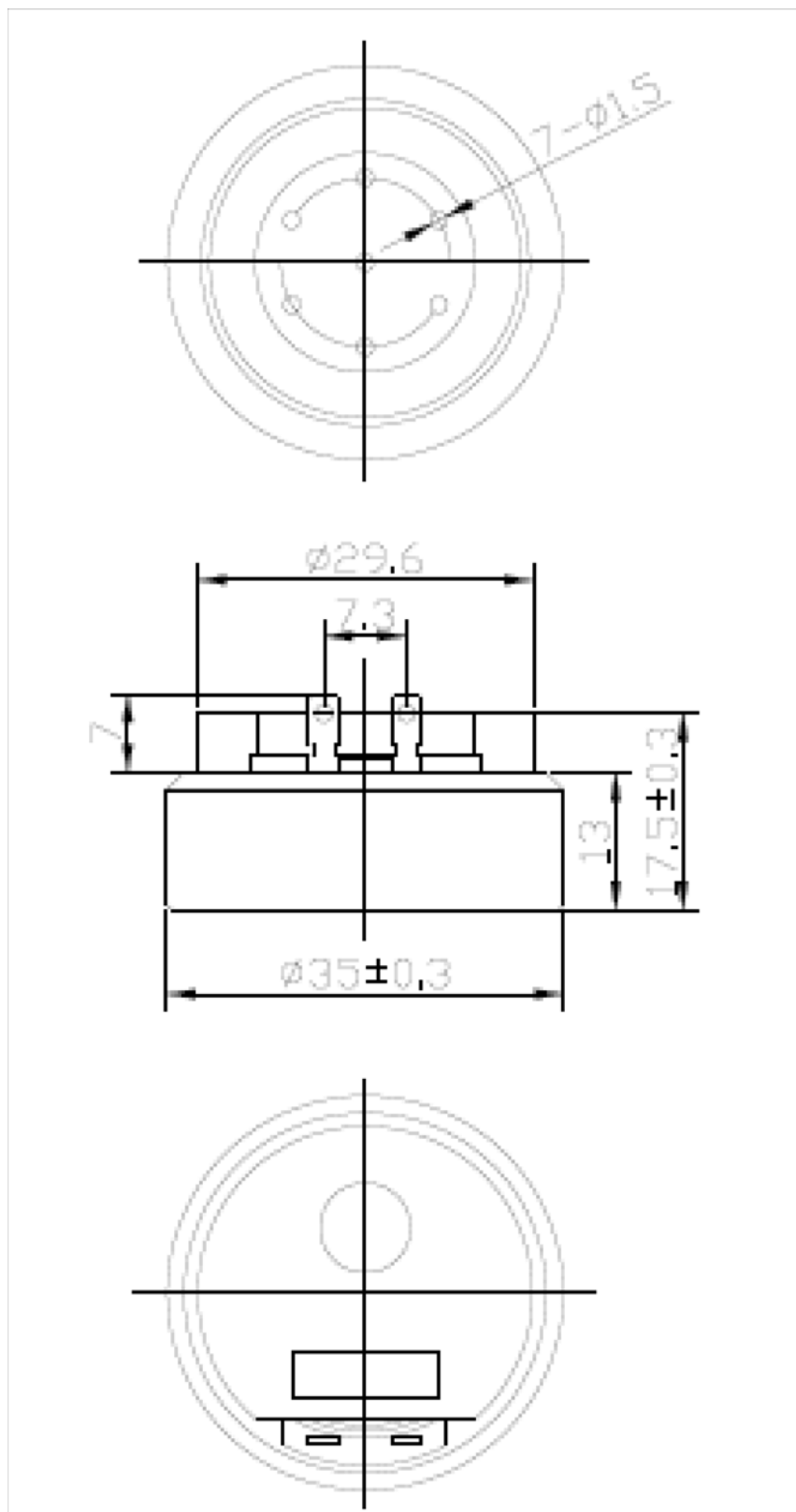

FIRST ANGLE PROJECTION



UNIT : mm  
Tolerance :  $\pm 2$

Specification for Receiver	Page	8/9
Model No. : KPDR300TH-6437	Revision No.	1.0
	Drawing No.	KFC6437

## 8. Packing

Each minimum package unit of products shall be in a carton box and it shall be clearly marked with Part Number, quantity and outgoing inspection number.

There shall be no mechanical damage on products during transportation and/or in storage.



