

Circuits from the Lab[®]
Reference Designs

Circuits from the Lab[®] reference designs are engineered and tested for quick and easy system integration to help solve today's analog, mixed-signal, and RF design challenges. For more information and/or support, visit www.analog.com/CN0251.

Devices Connected/Referenced	
ADG1409	4 Ω R _{ON} , 4-/8-Channel ±15 V/+12 V/±5 V iCMOS Multiplexer
AD8226	Low Cost, Wide Supply Range, Rail-to-Rail Output, Instrumentation Amplifier
AD8475	Precision, Selectable Gain, Fully Differential Funnel Amplifier
AD7192	4.8 kHz Ultralow Noise 24-Bit Sigma-Delta ADC with PGA
ADP1720-5	50 mA, High Voltage, Micropower Linear 5 V Regulator
ADR444	Ultralow Noise, LDO XFET Voltage

24-Bit, 4.7 Hz, 4-Channel Analog Data Acquisition System

EVALUATION AND DESIGN SUPPORT

Circuit Evaluation Boards

[CN-0251 Circuit Evaluation Board \(EVAL-CN0251-SDPZ\)](#)

[System Demonstration Platform \(EVAL-SDP-CB1Z\)](#)

Design and Integration Files

[Schematics, Layout Files, Bill of Materials](#)

CIRCUIT FUNCTION AND BENEFITS

The circuit shown in Figure 1 is a flexible signal conditioning circuit for processing signals of wide dynamic range, varying from several mV p-p to 20 V p-p. The circuit provides the necessary conditioning and level shifting and achieves the dynamic range using the internal programmable gain amplifier (PGA) of the high resolution analog-to-digital converter (ADC).

A ±10 V full-scale signal is very typical in process control and industrial automation applications; however, in some situations, the signal can be as small as several mV. Attenuation and level shifting is necessary to process a ±10 V signal with modern low voltage ADCs. However, amplification is needed for small signals to make use of the dynamic range of the ADC. Therefore, a circuit with a programmable gain function is desirable when the input signal varies over a wide range.

In addition, small signals may have large common-mode voltage swings; therefore, high common-mode rejection (CMR) is required. In some applications, where the source impedance is large, high impedance is also necessary for the analog front-end input circuit.

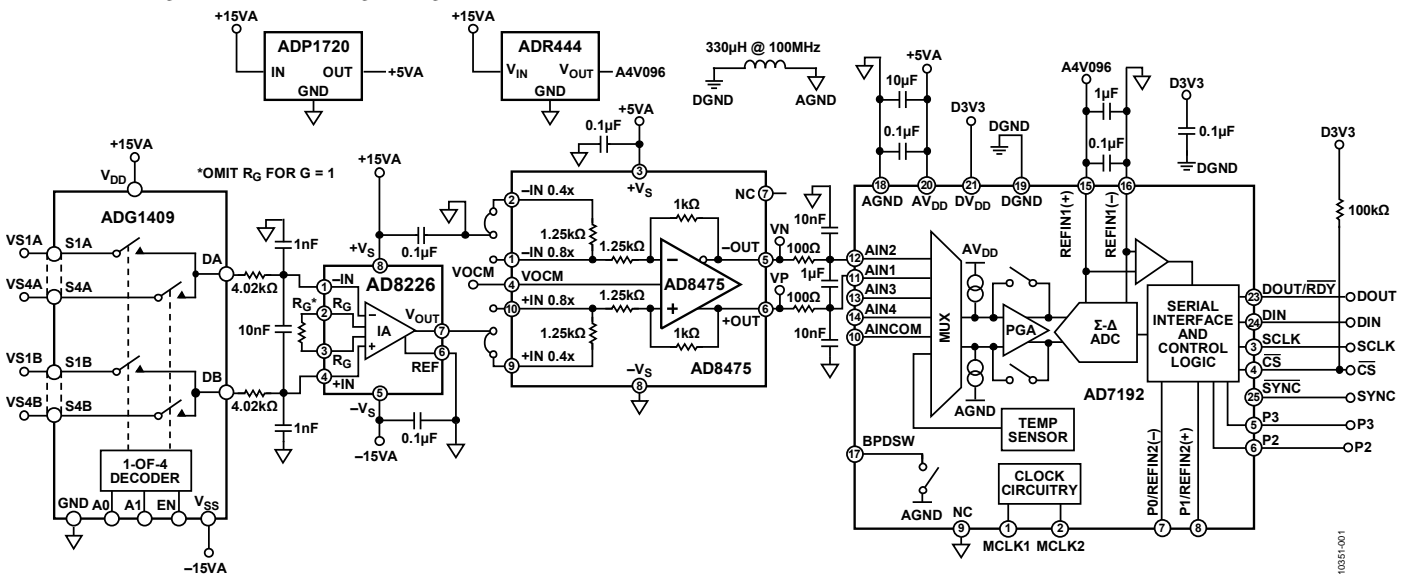

Figure 1. Flexible Analog Front-End Circuit for Wide Industrial Range Signal Conditioning

Rev. B

Circuits from the Lab[®] reference designs from Analog Devices have been designed and built by Analog Devices engineers. Standard engineering practices have been employed in the design and construction of each circuit, and their function and performance have been tested and verified in a lab environment at room temperature. However, you are solely responsible for testing the circuit and determining its suitability and applicability for your use and application. Accordingly, in no event shall Analog Devices be liable for direct, indirect, special, incidental, consequential or punitive damages due to any cause whatsoever connected to the use of any Circuits from the Lab circuits. (Continued on last page)

One Technology Way, P.O. Box 9106, Norwood, MA 02062-9106, U.S.A.
Tel: 781.329.4700 www.analog.com
Fax: 781.461.3113 ©2012–2013 Analog Devices, Inc. All rights reserved.

The circuit shown in Figure 1 solves all of these challenges and provides programmable gain, high CMR, and high input impedance. The input signal passes through the 4-channel [ADG1409](#) multiplexer into the [AD8226](#) low cost, wide input range instrumentation amplifier. The [AD8226](#) offers high CMR up to 80 dB and very high input impedance (800 M Ω differential mode and 400 M Ω common mode). A wide input range and rail-to-rail output allow the [AD8226](#) to make full use of the supply rails.

The [AD8475](#) is a fully differential, attenuating amplifier with integrated precision gain resistors. It provides precision attenuation ($G = 0.4$ or $G = 0.8$), common-mode level shifting, and single-ended-to-differential conversion. The [AD8475](#) is an easy to use, fully integrated precision gain block, designed to process signal levels up to ± 10 V on a single supply. Therefore, the [AD8475](#) is suitable for attenuating signals from the [AD8226](#) up to 20 V p-p, while maintaining high CMR and offering a differential output to drive the differential input ADC.

The [AD7192](#) is a 24-bit sigma-delta (Σ - Δ) ADC with an internal PGA. The on-chip, low noise gain stage ($G = 1, 8, 16, 32, 64, \text{ or } 128$) means that signals of large and small amplitude can be interfaced directly to the ADC.

With the combination of the previous parts, the circuit offers very good performance and easy configuration for signals with varying amplitudes. The circuit can be used in industrial automation, process control, instrumentation, and medical equipment applications.

CIRCUIT DESCRIPTION

The circuit comprises of an [ADG1409](#) multiplexer, an [AD8226](#) instrumentation amplifier, an [AD8475](#) difference amplifier, and an [AD7192](#) Σ - Δ ADC with an [ADR444](#) reference, and the [ADP1720](#) regulator. Only a few external components are used for protection, filtering, and decoupling, making this circuit highly integrated, and it requires a small circuit board (printed circuit board [PCB]) area.

Regulator and Reference Selection

The [ADP1720-5](#) was chosen as the 5 V regulator for this circuit. It is a high voltage micropower, low dropout linear regulator suitable for industrial applications.

The 4.096 V [ADR444](#) reference was chosen as the reference for this circuit. It is an ultralow noise, high accuracy, low dropout

device that is particularly suitable for high resolution, Σ - Δ ADCs and precision data acquisition systems.

Input Switch and Protection

The [ADG1409](#) multiplexer has 2-bit binary address lines that are used to select one of four possible input channels. The design also includes external protection such as standard diodes and transient voltage suppressors to enhance the robustness of the circuit. These are not shown in Figure 1; however, they are shown in the detailed schematics and other documentation in the [CN0251 Design Support Package](#).

The [ADG1409](#) multiplexer is configured to accept four differential input signals: (VS1A – VS1B), (VS2A – VS2B), (VS3A – VS3B), and (VS4A – VS4B). The outputs of the multiplexer, DA and DB, are applied to the inputs of the [AD8226](#) in-amp.

AD8226 Input Instrumentation Amplifier

The external R_G resistor sets the gain of the [AD8226](#). For this circuit, R_G is omitted, and the gain of the in-amp stage is 1. The output of the [AD8226](#) is therefore $VS_{xA} - VS_{xB}$, where x is the input channel number.

The differential input of the [AD8226](#) is filtered by two 4.02 k Ω resistors and a 10 nF capacitor, which form a single-pole RC filter with a cutoff frequency of 2.0 kHz. The two 1 nF capacitors add common-mode filtering with a cutoff frequency of 40 kHz.

AD7192 ADC PGA Gain Configuration

The [AD7192](#) is configured to accept differential analog inputs to match the differential output signals from the [AD8475](#). The full-scale input range of the [AD7192](#) is $\pm V_{REF}/\text{gain}$, where $\pm V_{REF} = \text{REFIN}_{X(+)} - \text{REFIN}_{X(-)}$.

When the buffer in the [AD7192](#) is enabled, the input channel drives the high impedance input stage of the buffer amplifier, and the absolute input voltage range in this mode is restricted to a range of $AGND + 250$ mV and $AV_{DD} - 250$ mV. When the gain stage is enabled, the output from the buffer is applied to the input of the PGA, and the analog input range must be limited to $\pm (AV_{DD} - 1.25 \text{ V})/\text{gain}$ because the PGA requires additional headroom. Therefore, with a 4.096 V reference and a 5 V power supply, and to make the maximum use of the dynamic range of the ADC, the signal can be attenuated or amplified as shown in Table 1.

Table 1. Gain Configurations for the [AD8475](#) and the [AD7192](#) Internal PGA for Various Input Ranges

Input Range (VSxA – VSxB)	Gain of AD8475	Gain of AD7192	PGA Output Range, Bipolar Mode (V)
± 10 V	0.4	1	± 4
± 5 V	0.8	1	± 4
± 1 V	0.4	8	± 3.2
± 500 mV	0.8	8	± 3.2
± 250 mV	0.8	16	± 3.2
± 125 mV	0.8	32	± 3.2
± 62.5 mV	0.8	64	± 3.2
± 31.25 mV	0.8	128	± 3.2

Differential Attenuating Amplifier

To drive the low voltage ADCs, the ± 10 V or ± 5 V signals require attenuation and level shifting. A difference amplifier configuration in conjunction with precision resistors inevitably degrades CMR performance due to the mismatch between the resistors. The [AD8475](#) level shifter/attenuator integrates matched, precision, laser trimmed resistors to ensure low gain error, a low gain drift (3 ppm/°C maximum), and high CMR.

The [AD8475](#) has pin-selectable gain options of 0.4 and 0.8. The VOVM pin adjusts the output voltage common mode for precision level shifting to match the input range of the ADC and to maximize the dynamic range. This pin can be left floating and is internally biased with a precision voltage divider consisting of two 200 k Ω resistors between the supplies and ground, thereby providing the midsupply voltage on the pin.

A single-pole differential RC filter composed of two 100 Ω resistors and a 1 μ F capacitor serves as an antialiasing and noise reduction filter for the [AD7192](#) with a cutoff frequency of 800 Hz. The two 10 nF capacitors provide common-mode filtering with a cutoff frequency of 160 kHz.

Filter, Output Data Rate, and Settling Time

The [AD7192](#) Σ - Δ ADC consists of a modulator followed by a digital filter. The output data rate (f_{ADC}) and settling time (t_{SETTLE}) are related to the filter configuration and the chop configuration. Table 2 shows the output data rates and settling time calculations for different configurations.

Table 2. Output Data Rate and Settling Time for Different Configurations

Chopper Filter Option	SINC3	SINC4
Disabled	$f_{\text{ADC}} = f_{\text{CLK}} / (1024 \times \text{FS}[9:0])$ $t_{\text{SETTLE}} = 3 / f_{\text{ADC}}$	$f_{\text{ADC}} = f_{\text{CLK}} / (1024 \times \text{FS}[9:0])$ $t_{\text{SETTLE}} = 4 / f_{\text{ADC}}$
Enabled	$f_{\text{ADC}} = f_{\text{CLK}} / (3 \times 1024 \times \text{FS}[9:0])$ $t_{\text{SETTLE}} = 2 / f_{\text{ADC}}$	$f_{\text{ADC}} = f_{\text{CLK}} / (4 \times 1024 \times \text{FS}[9:0])$ $t_{\text{SETTLE}} = 2 / f_{\text{ADC}}$

Layout Considerations

The performance of this or any other high speed or high resolution circuit is highly dependent on proper PCB layout. This includes, but is not limited to, power supply bypassing, signal routing, and proper power planes and ground planes. See [Tutorial MT-031](#), [Tutorial MT-101](#), and the article [A Practical Guide to High-Speed Printed-Circuit-Board Layout](#) for more detailed information regarding PCB layout.

System Performance

The 24-bit [AD7192](#) Σ - Δ ADC offers very good performance in this circuit. See the [Tutorial MT-022](#) and the [Tutorial MT-023](#) for more detailed information regarding the Σ - Δ ADCs.

With the configuration set to chop disabled, an output data rate of 4.7 Hz, a gain of 1, and a SINC4 filter, Figure 2 shows the noise performance, and Figure 3 shows the noise distribution histogram with 500 samples. The measured peak-to-peak noise of this circuit is approximately 3.9 μ V (see Figure 2), and the rms noise is 860 nV. This corresponds to a peak-to-peak (noise-free code) resolution of 20 bits and an rms resolution of 23 bits. Table 3 shows the rms noise for some of the data rates and gain settings of the [AD7192](#) with chop disabled and a SINC4 filter.

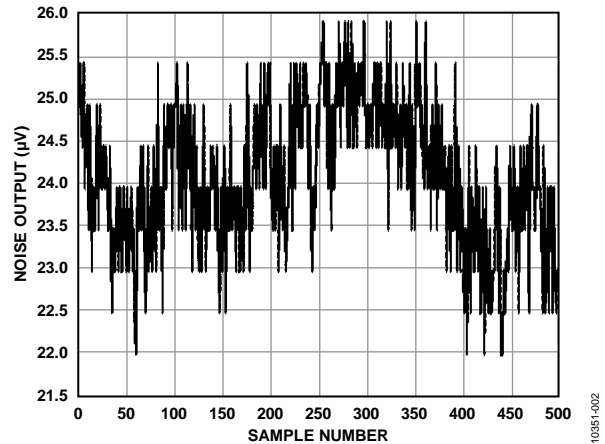

Figure 2. Noise Output ($V_{REF} = 4.096\text{ V}$, $AV_{DD} = 5\text{ V}$, Output Data Rate = 4.7 Hz, Gain = 1, Chop Disabled, SINC4 Filter)

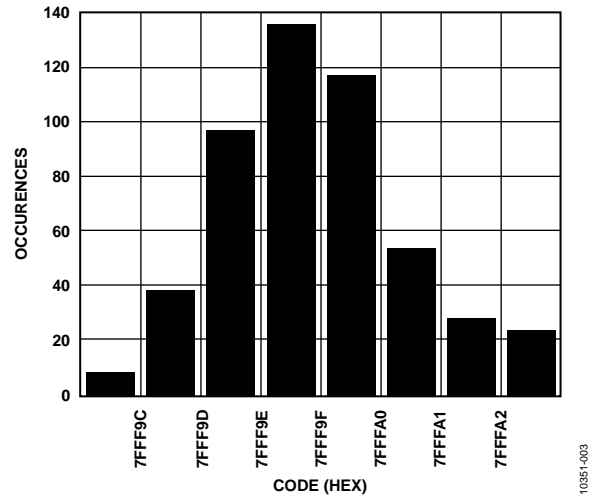

Figure 3. Noise Histogram ($V_{REF} = 4.096\text{ V}$, $AV_{DD} = 5\text{ V}$, Output Data Rate = 4.7 Hz, Gain = 1, Chop Disabled, SINC4 Filter)

Table 3. RMS Resolution of the System with Different Output Data Rates and Gain Settings of the [AD7192](#) with Chop Disabled and a SINC4 Filter (Subtract 2.7 Bits to Get Peak-to-Peak or Noise-Free Code Resolution)

Filter Word (Decimal)	Output Data Rate (Hz)	Settling Time (ms)	Gain 1	Gain 8	Gain 16	Gain 32	Gain 64	Gain 128
1023	4.7	852.5	23.0	21.8	20.4	19.7	18.8	17.4
640	7.5	533	22.5	21.5	20.0	19.5	18.5	17.2
96	50	80	22.3	20.9	19.8	19.3	18.2	17.0
16	300	13.3	21.8	20.2	19.3	18.6	17.6	16.8
5	960	4.17	20.9	19.8	18.9	18.0	17.2	16.2
1	4800	0.83	19.2	19.0	18.4	17.6	16.6	15.8

COMMON VARIATIONS

Other 24-bit or lower resolution Σ - Δ ADCs with integrated PGAs can be used, such as the [AD7190](#), [AD7193](#), [AD7797](#), and [AD7799](#). If no attenuation for the input signal is required, the [AD8476](#) can be used for lower power than the [AD8475](#).

In applications where there is no need for attenuation and high input impedance, the [AD7192](#) can be connected directly to the sensor to avoid noise introduced by the analog front-end conditioning circuits. For instance, a load cell with a small full-scale output voltage does not require attenuation and can be connected directly to the [AD7192](#) differential inputs (see the [CN-0102](#), [CN-0107](#), [CN-0108](#), [CN-0118](#), [CN-0119](#), and [CN-0155](#))

CIRCUIT EVALUATION AND TEST

The circuit test setup uses the [EVAL-CN0251-SDPZ](#) circuit evaluation board and the System Demonstration Platform (SDP) evaluation board ([EVAL-SDP-CB1Z](#)). The two boards have 120-pin mating connectors, allowing for the quick setup and evaluation of the performance of the circuit. The [EVAL-CN0251-SDPZ](#) board contains the circuit to be evaluated, as described in this circuit note, and the SDP is used with the [CN-0251](#) evaluation software to capture the data from the [EVAL-CN0251-SDPZ](#). The SDP is also used to control the input multiplexer and various functions within the [AD7192](#) ADC.

Equipment Needed

The following equipment is needed:

- A PC with a USB port and Windows XP or Windows Vista (32-bit) or Windows 7 (32-bit)
- An [EVAL-CN0251-SDPZ](#) circuit evaluation board
- An [EVAL-SDP-CB1Z](#) SDP evaluation board
- A dc supply: +15 V, -15 V, and +6 V.
- [CN-0251](#) evaluation software

Getting Started

Load the evaluation software by placing the [CN-0251](#) evaluation software CD in the CD drive of the PC. Then, locate the drive that contains the evaluation software CD and open the **Readme** file. Follow the instructions contained in the **Readme** file for installing and using the evaluation software.

Functional Block Diagram

Figure 4 shows a functional block diagram of the test setup. The [EVAL-CN0251-SDPZ-SCH.pdf](#) file has the detailed schematics for the [EVAL-CN0251-SDPZ](#). This file is contained in the CN-0251 Design Support Package: www.analog.com/CN0251-DesignSupport.

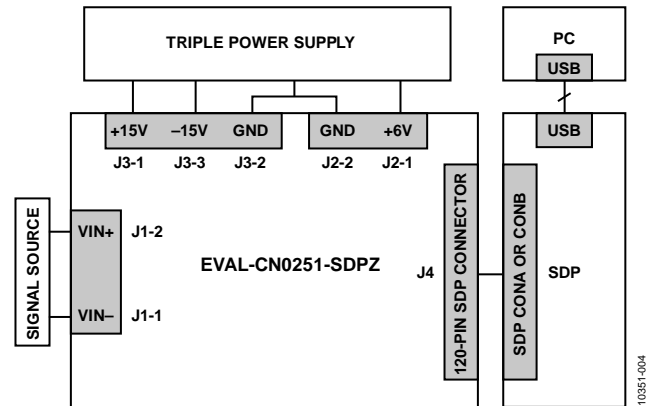

Figure 4. Test Setup Functional Block Diagram

Setup

Connect the 120-pin connector on the [EVAL-CN0251-SDPZ](#) to the CONA connector on the [EVAL-SDP-CB1Z](#) (SDP). Use nylon hardware to firmly secure the two boards, using the holes provided at the ends of the 120-pin connectors. After successfully setting the dc output supply to the +15 V, -15 V, and +6 V output, turn the power supply off.

With power to the supply off, connect a +15 V power supply to the +15VA pin of J3, a -15 V power supply to the -15VA pin of J3, and GND to the AGND pin of J3. Also, with power to the supply off, connect 6 V to J2. Turn on the power supply and then connect the USB cable with the SDP to the USB port on the PC. Do not connect the USB cable to the mini-USB connector on the SDP before turning on the dc power supply for the [EVAL-CN0251-SDPZ](#).

Test

After setting up the power supply and connecting to [EVAL-CN0251-SDPZ](#), launch the evaluation software and connect the USB cable from the PC to the mini-USB connector on the SDP. The software is able to communicate to the SDP if the Analog Devices System Development Platform driver is listed in the **Device Manager**.

Once USB communications are established, the SDP can now be used to send, receive, and capture serial data from the [EVAL-CN0251-SDPZ](#). Then, connect the signal source for measurements.

Information regarding the SDP can be found at www.analog.com/SDP.

LEARN MORE

MT-031 Tutorial, *Grounding Data Converters and Solving the Mystery of “AGND” and “DGND”*, Analog Devices.

MT-073 Tutorial, *High Speed Variable Gain Amplifiers (VGAs)*, Analog Devices.

MT-101 Tutorial, *Decoupling Techniques*, Analog Devices.

MT-022 Tutorial, *ADC Architectures III: Sigma-Delta ADC Basics*, Analog Devices.

MT-023 Tutorial, *ADC Architectures IV: Sigma-Delta ADC Advanced Concepts and Applications*, Analog Devices.

Data Sheets and Evaluation Boards

CN-0251 Circuit Evaluation Board (EVAL-CN0251-SDPZ)

System Demonstration Platform (EVAL-SDP-CB1Z)

AD8226 Data Sheet

AD8475 Data Sheet

AD7192 Data Sheet

ADG1409 Data Sheet

ADR444 Data Sheet

ADP1720 Data Sheet

REVISION HISTORY**12/13—Rev. A to Rev. B**

Changes to Title1

4/13—Rev. 0 to Rev. A

Changes to Circuit Evaluation and Test
Section.....5

6/12—Rev. 0: Initial Version

(Continued from first page) Circuits from the Lab reference designs are intended only for use with Analog Devices products and are the intellectual property of Analog Devices or its licensors. While you may use the Circuits from the Lab reference designs in the design of your product, no other license is granted by implication or otherwise under any patents or other intellectual property by application or use of the Circuits from the Lab reference designs. Information furnished by Analog Devices is believed to be accurate and reliable. However, Circuits from the Lab reference designs are supplied "as is" and without warranties of any kind, express, implied, or statutory including, but not limited to, any implied warranty of merchantability, noninfringement or fitness for a particular purpose and no responsibility is assumed by Analog Devices for their use, nor for any infringements of patents or other rights of third parties that may result from their use. Analog Devices reserves the right to change any Circuits from the Lab reference designs at any time without notice but is under no obligation to do so.

©2012–2013 Analog Devices, Inc. All rights reserved. Trademarks and registered trademarks are the property of their respective owners.
CN10351-0-12/13(B)

