

Specification for Approval

PRODUCT NUMBER: P25710
PRODUCT DESCRIPTION: RGS22128032WR004

CUSTOMER
APPROVED BY
DATE:

REVISION RECORD

REV.	REVISION DESCRIPTION	REV. DATE	REMARK
A01	INITIAL RELEASE	2018. 01. 15	

CONTENTS

ITEM	PAGE
<u>1. SCOPE</u>	4
<u>2. WARRANTY</u>	4
<u>3. FEATURES</u>	4
<u>4. MECHANICAL DATA</u>	5
<u>5. MAXIMUM RATINGS</u>	6
<u>6. ELECTRICAL CHARACTERISTICS</u>	6
6.1 D.C ELECTRICAL CHARACTERISTICS	
6.2 ELECTRO-OPTICAL CHARACTERISTICS	
<u>7. LIFETIME SPECIFICATION</u>	8
<u>8. INTERFACE</u>	9
8.1 FUNCTION BLOCK DIAGRAM	
8.2 PANEL LAYOUT DIAGRAM	
8.3 PIN ASSIGNMENTS	
8.4 GRAPHIC DISPLAY DATA RAM ADDRESS MAP	
8.5 INTERFACE TIMING CHART	
<u>9. POWER ON / OFF SEQUENCE & APPLICATION CIRCUIT</u>	13
9.1 POWER ON / OFF SEQUENCE	
9.2 APPLICATION CIRCUIT	
9.3 COMMAND TABLE	
<u>10. RELIABILITY TEST CONDITIONS</u>	15
<u>11. EXTERNAL DIMENSION</u>	16
<u>12. PACKING SPECIFICATION</u>	17
<u>13. OUTGOING INSPECTION PROVISION</u>	18
<u>14. APPENDIXES</u>	24

1. SCOPE

2. WARRANTY

3. FEATURES

- Small molecular organic light emitting diode.
- Color : White
- Panel matrix : 128x32
- Driver IC : SSD1305
- Excellent quick response time.
- Extremely thin thickness for best mechanism design : 2.027mm
- High contrast : 2000:1
- Wide viewing angle : 160°
- 8-bit 6800-series Parallel Interface, 8-bit 8080-series Parallel Interface, Serial Peripheral Interface, I²C Interface.
- Wide range of operating temperature : -40 to 70 °C
- Anti-glare polarizer.

4. MECHANICAL DATA

NO	ITEM	SPECIFICATION	UNIT
1	Dot Matrix	128 (W) x 32 (H)	dot
2	Dot Size	0.41 (W) x 0.39 (H)	mm ²
3	Dot Pitch	0.43 (W) x 0.41 (H)	mm ²
4	Aperture Rate	90	%
5	Active Area	55.02 (W) x 13.1 (H)	mm ²
6	Panel Size	62 (W) x 24 (H)	mm ²
7*	Panel Thickness	1.82 ± 0.1	mm
8	Module Size	62 (W) x 60 (H) x 2.027 (D)	mm ³
9	Diagonal A/A size	2.23	inch
10	Module Weight	5.78 ± 10%	gram

* Panel thickness includes substrate glass, cover glass and UV glue thickness.

5. MAXIMUM RATINGS

ITEM	MIN	MAX	UNIT	Condition	Remark
Supply Voltage (V_{DD})	-0.3	3.5	V	Ta = 25 °C	IC maximum rating
Supply Voltage (V_{CC})	8	16	V	Ta = 25 °C	IC maximum rating
Operating Temp.	-40	70	°C	-	-
Storage Temp	-40	85	°C	-	Note (2)
Humidity	-	85	%	-	-

Note:

- (1) Maximum ratings are those values beyond which damages to the OLED module may occur. The OLED functional operation should be restricted to the limits in the section 6. Electrical Characteristics tables.
- (2) The defined temperature ranges do not include the polarizer. The maximum withstood temperature of the polarizer should be 80 °C.

6. ELECTRICAL CHARACTERISTICS

6.1 D.C ELECTRICAL CHARACTERISTICS

SYMBOL	PARAMETERS	TEST CONDITION	MIN	TYP	MAX	UNIT
V_{CC}	Analog power supply (for OLED panel)	Ta = 25 °C	12	12.5	13	V
V_{DD}	Digital power supply	Ta = 25 °C	2.4	-	3.5	V
V_{DDIO}	Power supply for I/O pins	-	1.6	-	V_{DD}	V
V_{IH}	Hi logic input level		0.8* V_{DDIO}	-	-	V
V_{IL}	Low logic input level		-	-	0.2* V_{DDIO}	V
V_{OH}	Hi logic output level		0.9* V_{DDIO}	-	-	V
V_{OL}	Low logic output level		-	-	0.1* V_{DDIO}	V

6.2 ELECTRO-OPTICAL CHARACTERISTICS

PANEL ELECTRICAL SPECIFICATIONS

PARAMETER	MIN	TYP.	MAX	UNITS	COMMENTS
Normal mode current (ICC)	-	33	35	mA	All pixels on (1)
Standby mode current consumption (ICC)	-	2	3	mA	Standby mode 10% pixels on(2)
Normal mode power consumption	-	412.5	437.5	mW	All pixels on (1)
Standby mode power consumption	-	25	37.5	mW	Standby mode 10% pixels on(2)
IDD sleep mode current	-	-	10	uA	Sleep mode Current (3)
ICC sleep mode current	-	-	10	uA	Sleep mode Current (3)
Normal Luminance	160	180		cd/m ²	Display Average
Standby Luminance	-	20			
CIE _x (White)	0.26	0.30	0.34		x, y (CIE 1931)
CIE _y (White)	0.29	0.33	0.37		
Dark Room Contrast	2000:1				
Viewing Angle	160			degree	
Response Time		10		μs	

(1) Normal mode condition :

- Driving Voltage : 12.5V
- Contrast setting : 0xae
- Set Vcomh: 0x3c
- Frame rate : 105Hz
- Duty setting : 1/32

(2) Standby mode condition :

- Driving Voltage : 12.5V
- Contrast setting : 0x0f
- Set Vcomh: 0x3c
- Frame rate : 105Hz
- Duty setting : 1/32

(3) Sleep mode condition :

When send 0xAE command OLED display off and memory data will be maintained.

(4) Wake up condition :

When send 0xAF command OLED will be turned on.

7. LIFETIME SPECIFICATION

ITEM	MIN	UNIT	Condition	Remark
Life Time	15,000	Hrs	200 cd/m ² , 50% alternating checkerboard	Note (1)
Life Time	16,000	Hrs	180 cd/m ² , 50% alternating checkerboard	Note (2)
Life Time	18,000	Hrs	160 cd/m ² , 50% alternating checkerboard	Note (3)

Note:

- (A) Under Vcc = 12.5V, Ta = 25 °C, 50% RH.
- (B) Life time is defined the amount of time when the luminance has decayed to less than 50% of the initial measured luminance.
- (C) More command setting (Initial code), please see the application note.

(1) Setting of 200 cd/m² :

- Contrast setting : 0xc6
- Set Vcomh: 0x3c
- Frame rate : 105Hz
- Duty setting : 1/32

(2) Setting of 180 cd/m² :

- Contrast setting : 0xae
- Set Vcomh: 0x3c
- Frame rate : 105Hz
- Duty setting : 1/32

(3) Setting of 160 cd/m² :

- Contrast setting : 0x9a
- Set Vcomh: 0x3c
- Frame rate : 105Hz
- Duty setting : 1/32

8. INTERFACE

8.1 FUNCTION BLOCK DIAGRAM

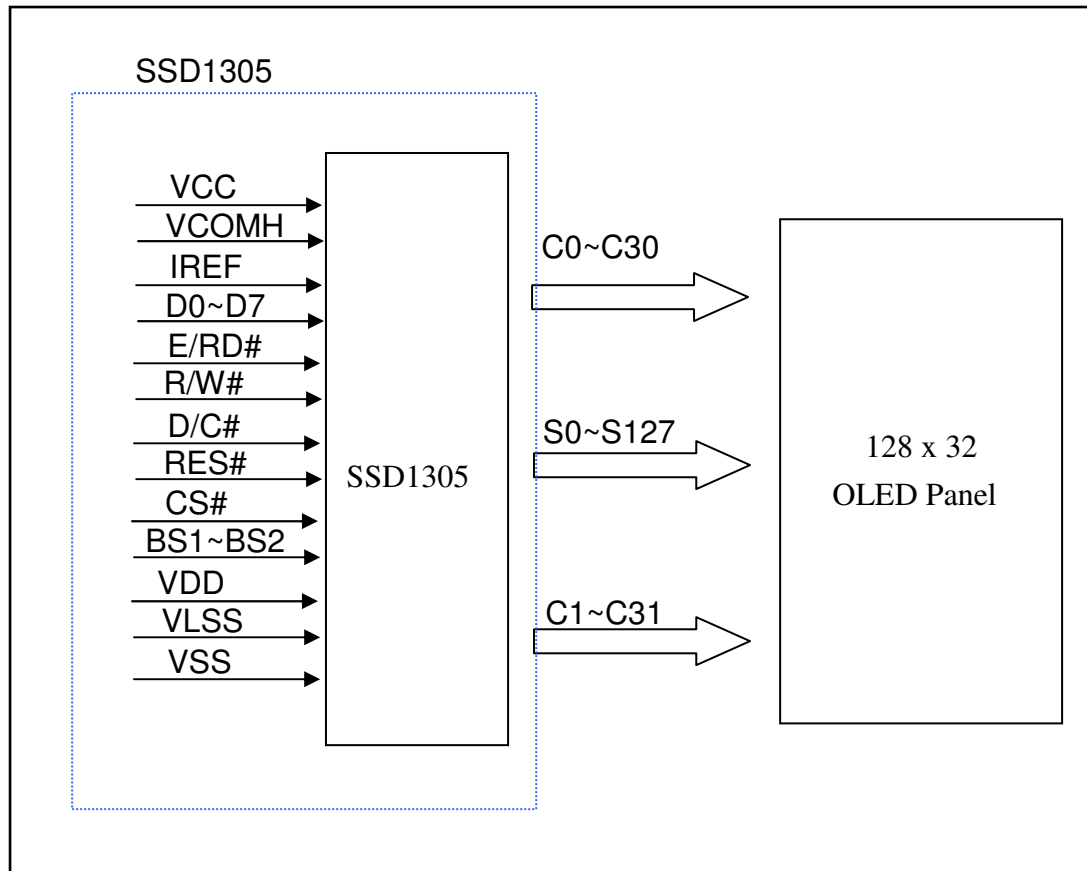

RiTdisplay 128x32 OLED Module

8.2 PANEL LAYOUT DIAGRAM

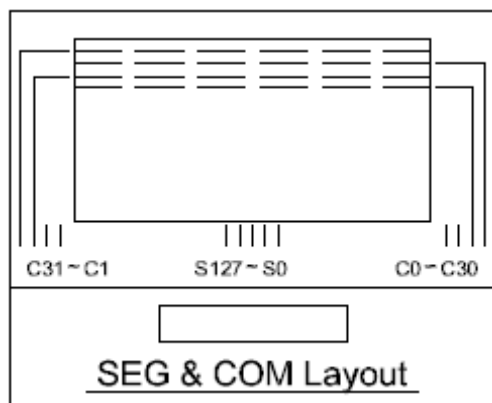

8.3 PIN ASSIGNMENTS

PIN NAME	PIN NO.	DESCRIPTION	Setting at each interface		
			8080 parallel	SPI	IIC
1	NC	No connection.			
2	VLSS	It should be connect to Vss externally.			
3	VSS	This is ground pin.			
4	NC	No connection.			
5	VDD	Power supply pin for core logic operation.			
6	BS1	MCU bus interface selection pins.	High	Low	High
7	BS2		High	Low	Low
8	CS#	Chip select input.	CS#	CS#	Low
9	RES#	Reset signal input.	RES#	RES#	RES#
10	D/C#	Data/ Command control.	D/C#	D/C#	SA0
11	R/W#	MCU interface input.	WR	Low	Low
12	E/RD#	MCU interface input.	RD#		
13	D0	Data Bus.	D0	SCLK	SCL
14	D1		D1	SDIN	SDAIN
15	D2		D2	NC	SDA _{OUT}
16	D3		D3	Low	Low
17	D4		D4		
18	D5		D5		
19	D6		D6		
20	D7		D7		
21	IREF	Reference current input pin.			
22	VCOMH	Com Voltage Output. A capacitor should be connected between this pin and VSS.			
23	VCC	Power supply for panel driving voltage.			
24	NC	No connection.			

Note

- (1) Low is connected to VSS
- (2) High is connected to VDD

8.5 INTERFACE TIMING CHART

Serial Interface Timing Characteristics

($V_{DD} - V_{SS} = 2.4V$ to $3.5V$, $V_{DDIO} = V_{DD}$, $T_A = 25^\circ C$)

Symbol	Parameter	Min	Typ	Max	Unit
t_{cycle}	Clock Cycle Time	250	-	-	ns
t_{AS}	Address Setup Time	150	-	-	ns
t_{AH}	Address Hold Time	150	-	-	ns
t_{CSS}	Chip Select Setup Time	120	-	-	ns
t_{CSH}	Chip Select Hold Time	60	-	-	ns
t_{DSW}	Write Data Setup Time	50	-	-	ns </td
t_{DHW}	Write Data Hold Time	15	-	-	ns
t_{CLKL}	Clock Low Time	100	-	-	ns
t_{CLKH}	Clock High Time	100	-	-	ns
t_R	Rise Time	-	-	40	ns
t_F	Fall Time	-	-	40	ns

Serial Interface Characteristics

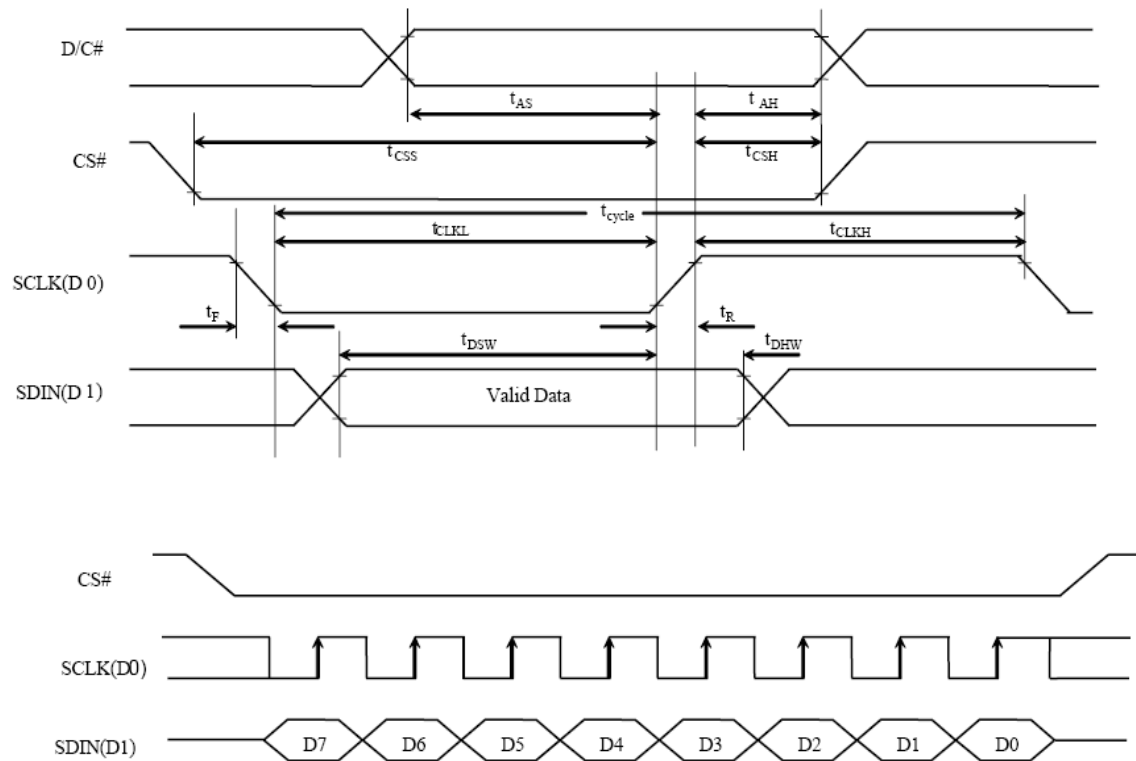

9. POWER ON / OFF SEQUENCE & APPLICATION CIRCUIT

9.1 POWER ON / OFF SEQUENCE

The following figures illustrate the recommended power ON and power OFF sequence of SSD1305.

Power ON sequence :

1. Power ON V_{DD} , V_{DDIO} .
2. After V_{DD} , V_{DDIO} become stable, set RES# pin LOW (logic low) for at least $3\mu s(t_1)^{(4)}$ and then HIGH (logic high).
3. After set RES# pin LOW (logic low), wait for at least $3\mu s(t_2)$. Then Power ON $V_{CC}^{(1)}$.
4. After V_{CC} become stable, send command AFh for display ON. SEG/COM will be ON after $100ms(t_{AF})$.

The Power ON sequence

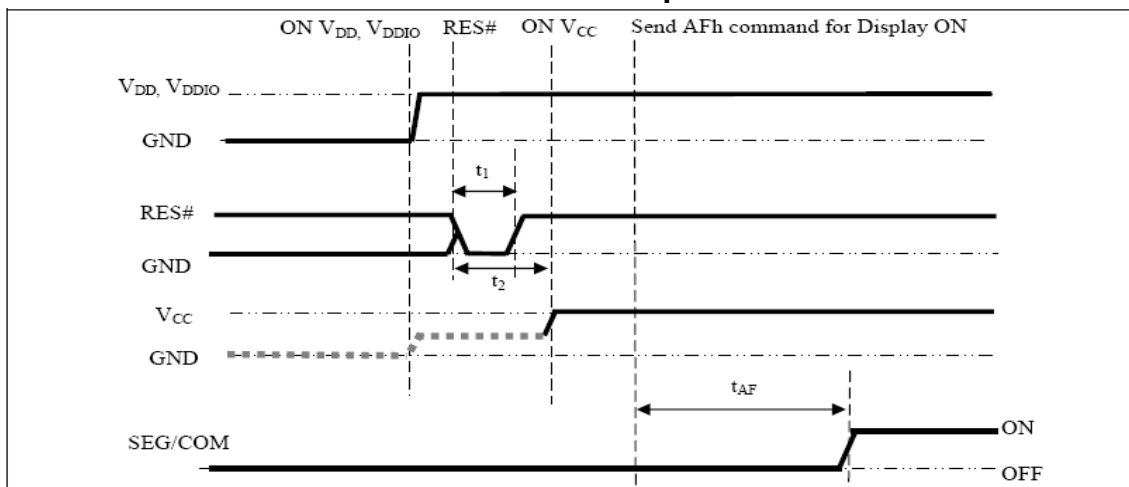

Power OFF sequence:

1. Send command AEh for display OFF.
2. Power OFF $V_{CC}^{(1), (2), (3)}$
3. Wait for t_{OFF} . Power OFF V_{DD}, V_{DDIO} . (where Minimum $t_{OFF}=80ms^{(5)}$, Typical $t_{OFF}=100ms$)

The Power OFF sequence

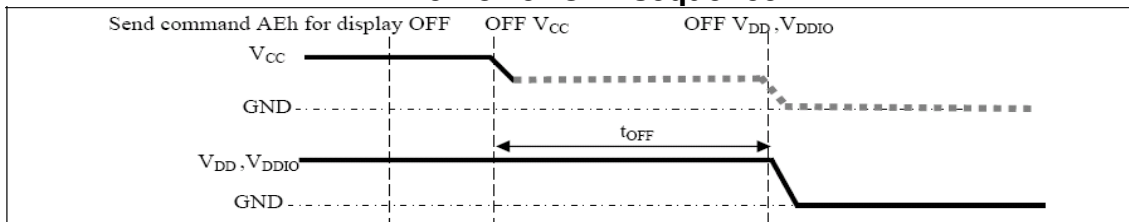

Note:

- (1) Since an ESD protection circuit is connected between V_{DD} , V_{DDIO} and V_{CC} , V_{CC} becomes lower than V_{DD} whenever V_{DD} , V_{DDIO} is ON and V_{CC} is OFF as shown in the dotted line of V_{CC} in above figures.
- (2) V_{CC} should be kept disabled when it is OFF.
- (3) Power Pins(V_{DD} , V_{CC}) can never be pulled to ground under any circumstance.
- (4) The register values are reset after t_1 .
- (5) V_{DD} should not be Power OFF before V_{CC} Power OFF.

9.2 APPLICATION CIRCUIT

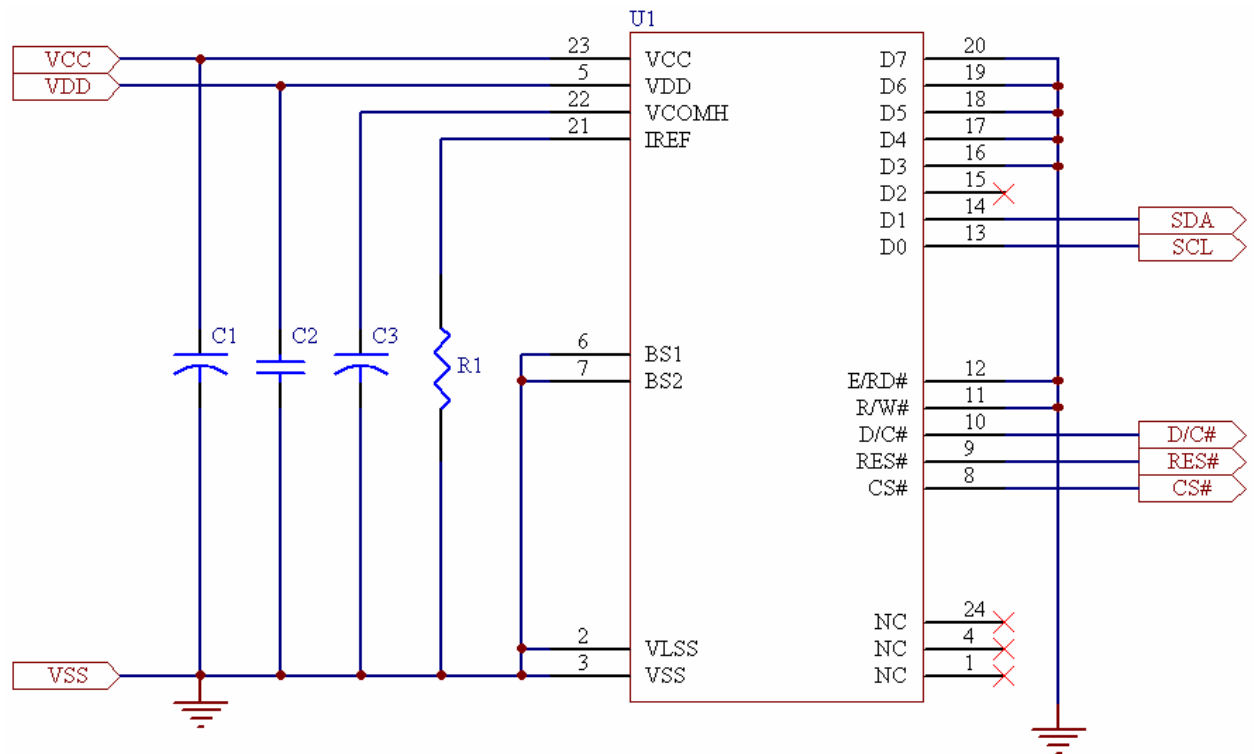

Recommend components :

C1 、 C3 : 4.7uF/25V Tantalum type or VISHAY(572D475X0025A2T)

C2 : 4.7uF/16V (0805)

R1 : 1M ohm 1% (0603)

This circuit is designed for SPI interface.

9.3 COMMAND TABLE

Refer to SSD1305 IC Spec.

10. RELIABILITY TEST CONDITIONS

No.	Items	Specification	Quantity
1	High temp. (Non-operation)	85 °C, 240hrs	5
2	High temp. (Operation)	70 °C, 120hrs	5
3	Low temp. (Operation)	-40 °C, 120hrs	5
4	High temp. / High humidity (Operation)	65 °C, 90%RH, 120hrs	5
5	Thermal shock (Non-operation)	-40 °C ~85 °C (-40 °C /30min; transit /3min; 85 °C /30min; transit /3min) 1cycle: 66min, 100 cycles	5
6	Vibration	Frequency : 5~50HZ, 0.5G Scan rate : 1 oct/min Time : 2 hrs/axis Test axis : X, Y, Z	1 Carton
7	Drop	Height: 120cm Sequence : 1 angle 、3 edges and 6 faces Cycles: 1	1 Carton
8	ESD (Non-operation)	Air discharge model, ±8kV, 10 times	5

Test and measurement conditions

1. All measurements shall not be started until the specimens attain to temperature stability.
2. The degradation of Polarizer are ignored for item 1, 4 & 5.

Evaluation criteria

1. The function test is OK.
2. No observable defects.
3. Luminance: > 50% of initial value.
4. Current consumption: within \pm 50% of initial value.

11. EXTERNAL DIMENSION

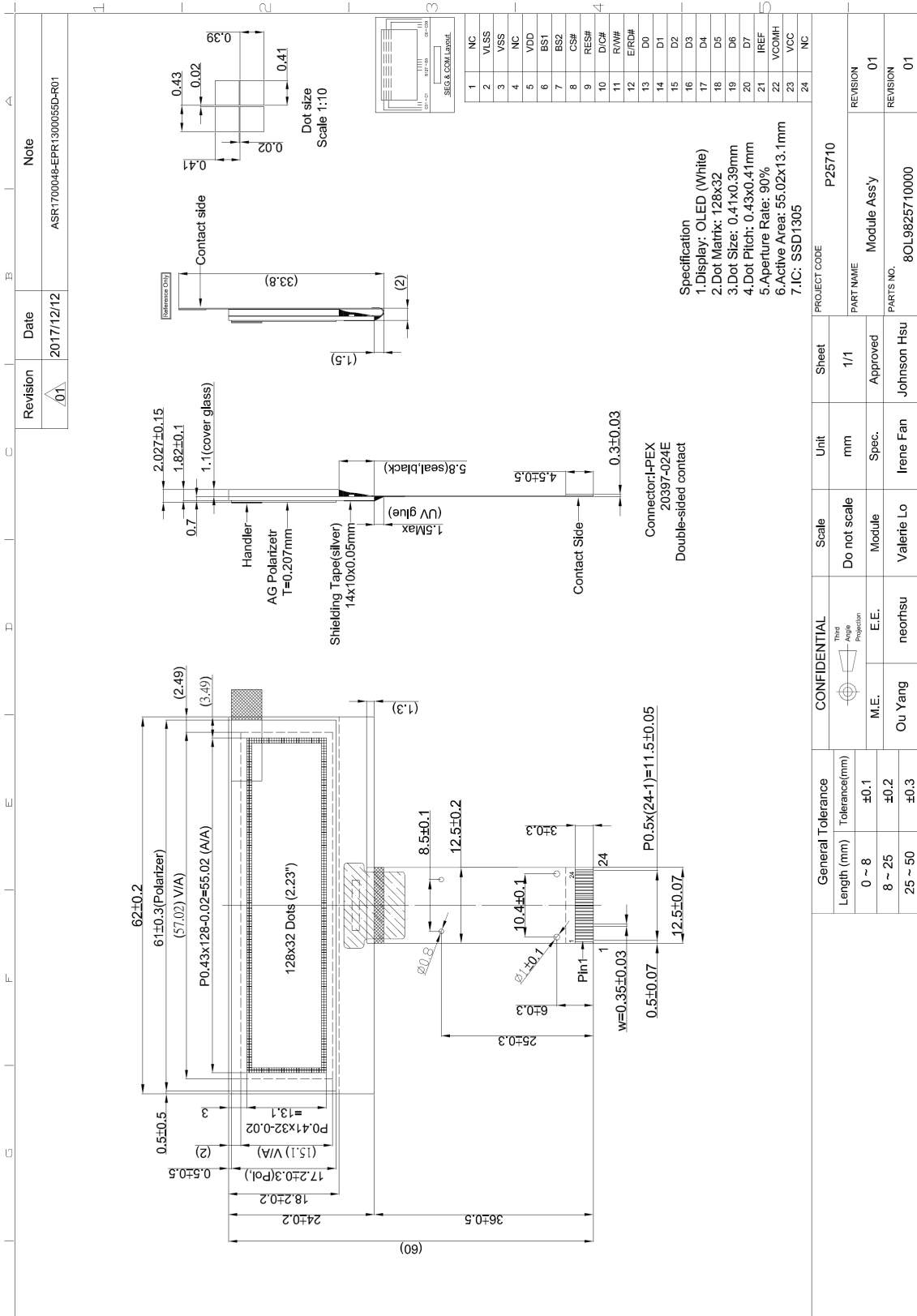

12. PACKING SPECIFICATION

	Revision 01	Date 2017/12/12	Note Packing Tray Instruction
--	----------------	--------------------	----------------------------------

① 80L9825710000
MODULE ASSY FOR P25710 WHITE

② 700P2570210
Tray 330x270x8.7 T:0.5mm PET P25702

③ 7003010000001
7003010001001
5G 乾燥劑

④ 7003003001011
真空包裝袋,285x90x480mm ANTIS

⑤ 5RTD3003000016
Antistatic Bubble Bag 440x(350+100)mm

⑥ 7003001000001
PIZZA BOX 345x285x88mm,B浪,ROHS

⑦ 7003000000001
單色CARTON 385x305x203mm,AB浪,ROHS

⑧ RTD30060000000
HI-FI LABEL 8cm*8cm

⑨ RTD3208000125
封箱膠帶,W=48mm,L=910cm

Tray =21 pcs

Tray =20 pcs

rotate stack
旋轉堆疊

x4 pcs

x21 pcs

x20 pcs

x1 pcs

x2 pcs

ITEM	PART No.	DESC	QTY
	90L9825710000		
1	80L9825710000	MODULE ASSY FOR P25710 WHITE	640
2	700P257021002	Tray 330x270x8.7 T:0.5mm PET P25702	42
3	7003010000001	5G 矽膠乾燥劑COBALT DICHLORIDE FREE 透明	8
3	7003010001001	5G BENTONITE DESICCANT 膨潤土乾燥劑	8
4	7003003001011	真空包裝袋,285x90x480mm ANTIS	2
5	RTD30030000016	ANTI STATIC BUBBLE BAG 440*(350+100)mm	2
6	7003001000001	PIZZA BOX 345x285x88mm,B浪,ROHS	2
7	7003000000001	單色CARTON 385x305x203mm,AB浪,ROHS	1
8	RTD30060000000	HI-FI LABEL 8cm*8cm	3
9	RTD3208000125	封箱膠帶,48mm*910cm,OPP	

General Tolerance	Length (mm)	0 ~ 8	8 ~ 25	25 ~ 50	±0.1	±0.2	±0.3
Scale	x	Module	Valerie Lo	Irene Fan	Johnson Hsu	Approved	PARTS NO.
Sheet	1/1	Spec.	Valerie Lo	Irene Fan	Johnson Hsu	Approved	PARTS NO.
PROJECT CODE	P25710		PART NAME		Packing Tray Instruction		VERSION
						01	
						90L9825710000	
						VERSION	
						01	

13. OUTGOING INSPECTION PROVISION**1. 抽樣方法 / SAMPLING METHOD**

- (1) MIL-STD-1916 / 驗證水準 level III / 正常檢驗 / 單次樣品檢驗
MIL-STD-1916 / inspection level III / normal inspection / single sample inspection
- (2) 主要缺陷 Level III ; 次要缺陷 Level II
Major Level III ; Minor Level II

MIL-STD-1916 樣本代字對照表							
批量	驗證水準 (VL)						
	VII	VI	V	IV	III	II	I
2 ~ 170	A	A	A	A	A	A	A
171 ~ 288	A	A	A	A	A	A	B
289 ~ 544	A	A	A	A	A	B	C
545 ~ 960	A	A	A	A	B	C	D
961 ~ 1632	A	A	A	B	C	D	E
1633 ~ 3072	A	A	B	C	D	E	E
3073 ~ 5440	A	B	C	D	E	E	E
5441 ~ 9216	B	C	D	E	E	E	E
9217 ~ 17408	C	D	E	E	E	E	E
17409 ~ 30720	D	E	E	E	E	E	E
≥ 30721	E	E	E	E	E	E	E

2. 檢驗條件 / INSPECTION CONDITION

檢查和測量在下列條件下進行的，除非另有規定。

The inspection and measurement are performed under the following conditions, unless otherwise specified.

溫度 / Temperature: 25±5 °C

濕度 / Humidity: 50±10%R.H.

壓力 / Pressure: 860~1060hPa (mbar)

檢驗員拿的面板和眼睛之間的距離 / Distance between the panel and eyes of the inspector ≥ 30cm

3. 品質檢驗規格 / SPECIFICATION FOR QUALITY CHECK

3.1 缺陷分類 / DEFECT CLASSIFICATION

嚴重度 Severity	檢驗項目 Inspection Item	缺陷 Defect	備註 Remark
主要缺陷 Major Defect	1. 面板 Panel	(1) 無顯示 Non-displaying	
		(2) 線缺陷 Line defects	
		(3) 故障 Malfunction	
		(4) 玻璃破損 Glass cracked	
	2. 軟板 Film	(1) 軟板尺寸超規 Film dimension out of specification	不能組裝 Can not be assembled
	3. 尺寸 Dimension	(1) 外形尺寸超規 Outline dimension out of specification	
次要缺陷 Minor Defect	1. 面板 Panel	(1) 玻璃刮傷 Glass scratch	外觀缺陷 Appearance defect
		(2) 玻璃切割異常 Glass cutting NG	
		(3) 玻璃崩邊、崩角 Glass chip	
	2. 偏光板 Polarizer	(1) 偏光板刮傷 Polarizer scratch	
		(2) 表面汙漬 Stains on surface	
		(3) 偏光板氣泡 Polarizer bubbles	
	3. 顯示 Displaying	(1) 暗點、亮點、髒污 Dim spot·Bright spot·dust	
	4. 軟板 Film	(1) 損傷 Damage	
		(2) 異物 Foreign material	

3.2 出貨規格 / OUTGOING SPECIFICATION

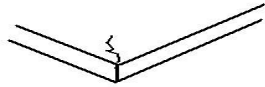
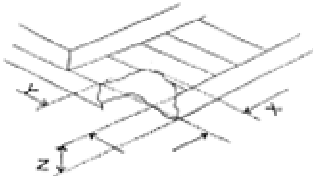
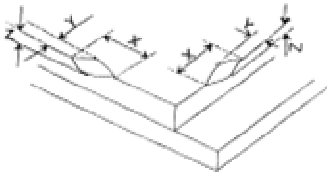
項目 Item	描述 Description	標準 Criterion	允收 水準 AQL															
I. 面板 Panel	1. 玻璃刮傷 Glass scratch	<table border="1" data-bbox="699 421 1318 891"> <thead> <tr> <th data-bbox="699 421 935 573">寬 / Width (mm) W</th> <th data-bbox="935 421 1126 573">長 / Length (mm) L</th> <th data-bbox="1126 421 1318 573">容許個數 number of pieces permitted</th> </tr> </thead> <tbody> <tr> <td data-bbox="699 573 935 656">$W \leq 0.03$</td> <td data-bbox="935 573 1126 656">忽略 Ignore</td> <td data-bbox="1126 573 1318 656">忽略 Ignore</td> </tr> <tr> <td data-bbox="699 656 935 734">$0.03 < W \leq 0.05$</td> <td data-bbox="935 656 1126 734">$L \leq 1$</td> <td data-bbox="1126 656 1318 734">1</td> </tr> <tr> <td data-bbox="699 734 935 813">$0.05 < W$</td> <td data-bbox="935 734 1126 813">-----</td> <td data-bbox="1126 734 1318 813">無 None</td> </tr> <tr> <td data-bbox="699 813 935 891">顯示區外 beyond A.A.</td> <td data-bbox="935 813 1126 891">-----</td> <td data-bbox="1126 813 1318 891">忽略 Ignore</td> </tr> </tbody> </table>	寬 / Width (mm) W	長 / Length (mm) L	容許個數 number of pieces permitted	$W \leq 0.03$	忽略 Ignore	忽略 Ignore	$0.03 < W \leq 0.05$	$L \leq 1$	1	$0.05 < W$	-----	無 None	顯示區外 beyond A.A.	-----	忽略 Ignore	次要 Minor
	寬 / Width (mm) W	長 / Length (mm) L	容許個數 number of pieces permitted															
$W \leq 0.03$	忽略 Ignore	忽略 Ignore																
$0.03 < W \leq 0.05$	$L \leq 1$	1																
$0.05 < W$	-----	無 None																
顯示區外 beyond A.A.	-----	忽略 Ignore																
	2. 玻璃破損 Glass crack	<p data-bbox="671 981 1238 1099">(1) 裂紋 / Crack 擴展裂紋是不能接受的。 Propagation crack is not acceptable.</p> 	主要 Major															
	3. 玻璃崩邊、崩角 Glass chip	<p data-bbox="671 1299 1038 1339">(1) 崩角 / Chip on corner</p>  <p data-bbox="671 1570 1015 1610">(2) 崩邊 / Chip on edge</p> 	次要 Minor															

項目 Item	描述 Description	標準 Criterion	允收 水準 AQL																
I. 面板 Panel	3. 玻璃崩邊、崩角 Glass chip	<table border="1"> <thead> <tr> <th>崩角 Chip on corner</th> <th>Size (mm)</th> <th>崩邊 Chip on edge</th> <th>Size (mm)</th> </tr> </thead> <tbody> <tr> <td>X</td> <td>≤1.5</td> <td>X</td> <td>≤3.0</td> </tr> <tr> <td>Y</td> <td>≤2.0</td> <td>Y</td> <td>≤1.0</td> </tr> <tr> <td>Z</td> <td>≤t</td> <td>Z</td> <td>≤t</td> </tr> </tbody> </table> <p>備註 / Note: 1. t = 玻璃厚度 t = glass thickness 2. 崩邊或崩角延伸到 ITO 導線是不能接受的。 Chip on the corner extending into the ITO contact is not acceptable.</p>	崩角 Chip on corner	Size (mm)	崩邊 Chip on edge	Size (mm)	X	≤1.5	X	≤3.0	Y	≤2.0	Y	≤1.0	Z	≤t	Z	≤t	次要 Minor
	崩角 Chip on corner	Size (mm)	崩邊 Chip on edge	Size (mm)															
X	≤1.5	X	≤3.0																
Y	≤2.0	Y	≤1.0																
Z	≤t	Z	≤t																
	4. 尺寸 Dimension	請參閱圖紙的規範。 Refer to the drawing of the spec	主要 Major																
II. 偏光板 Polarizer	1. 刮傷 Scratch	點狀按照“項目 II-3 偏光板氣泡”的標準。 Spot type in accordance with the criteria of “Item II-3. Polarizer bubble”. 線狀按照“項目 I-1 玻璃刮傷”的標準。 Line type in accordance with the criteria of “Item I-1. Glass scratch”.	次要 Minor																
	2. 表面汗漬 Stains on surface	表面汗漬無法用軟布或類似的清潔物輕輕擦拭去除。 Stains cannot be removed even when wiped lightly with a soft cloth or similar cleaning.	次要 Minor																
	3. 偏光板氣泡 Polarizer bubble	<p style="text-align: center;">(mm)</p> <table border="1"> <thead> <tr> <th>尺寸 Size</th> <th>容許個數 number of pieces permitted</th> </tr> </thead> <tbody> <tr> <td>$\Phi \leq 0.2$</td> <td>忽略 Ignore</td> </tr> <tr> <td>$0.2 < \Phi \leq 0.5$</td> <td>2</td> </tr> <tr> <td>$0.5 < \Phi$</td> <td>0</td> </tr> <tr> <td>顯示區外 beyond A.A.</td> <td>忽略 Ignore</td> </tr> </tbody> </table>	尺寸 Size	容許個數 number of pieces permitted	$\Phi \leq 0.2$	忽略 Ignore	$0.2 < \Phi \leq 0.5$	2	$0.5 < \Phi$	0	顯示區外 beyond A.A.	忽略 Ignore	次要 Minor						
尺寸 Size	容許個數 number of pieces permitted																		
$\Phi \leq 0.2$	忽略 Ignore																		
$0.2 < \Phi \leq 0.5$	2																		
$0.5 < \Phi$	0																		
顯示區外 beyond A.A.	忽略 Ignore																		

項目 Item	描述 Description	標準 Criterion	允收 水準 AQL											
III. 顯示 Displaying	1. 耗電 Power consumption	該模組的工作電流消耗不應超出產品規格書的規範。 The module operating current consumption should not go beyond the standard indicated in Product Specification	主要 Major											
	2. 像素尺寸 Pixel size	顯示像素的尺寸的公差應規格的±25%之內。 The tolerance of display pixel dimension should be within ±25% of specification.	次要 Minor											
	3. 顏色 Color	依據產品規格。 Refer to the product specification.	主要 Major											
	4. 亮度 Luminance	依據產品規格。 Refer to the product specification.	主要 Major											
	5. 暗點、亮點、 髒污 Dimming spot、Lighting spot、Dust	1. <table border="1" style="margin-left: 20px;"> <thead> <tr> <th>平均直徑 Average diameter D:(mm)</th> <th>容許個數 number of pieces permitted</th> </tr> </thead> <tbody> <tr> <td>D ≤ 0.1</td> <td>忽略 Ignore</td> </tr> <tr> <td>0.1 < D ≤ 0.15</td> <td>1</td> </tr> <tr> <td>0.15 < D ≤ 0.2</td> <td>1</td> </tr> <tr> <td>0.2 < D</td> <td>0</td> </tr> <tr> <td>顯示區外 beyond A.A.</td> <td>忽略 Ignore</td> </tr> </tbody> </table> <p>D=(長邊直徑 + 短邊直徑)/2 D=(long diameter + short diameter)/2 像素暗點是不允許。 Pixel off is not allowed.</p>	平均直徑 Average diameter D:(mm)	容許個數 number of pieces permitted	D ≤ 0.1	忽略 Ignore	0.1 < D ≤ 0.15	1	0.15 < D ≤ 0.2	1	0.2 < D	0	顯示區外 beyond A.A.	忽略 Ignore
平均直徑 Average diameter D:(mm)	容許個數 number of pieces permitted													
D ≤ 0.1	忽略 Ignore													
0.1 < D ≤ 0.15	1													
0.15 < D ≤ 0.2	1													
0.2 < D	0													
顯示區外 beyond A.A.	忽略 Ignore													

項目 Item	描述 Description	標準 Criterion	允收 水準 AQL		
III. 顯示 Displaying	5. 暗點、亮點、 髒污 Dimming spot、Lighting spot、Dust	2.	次要 Minor		
		寬 width(mm) W		長 length(mm) L	容許個數 number of pieces permitted
		$W \leq 0.03$		忽略 Ignore	忽略 Ignore
		$0.03 < W \leq 0.05$		$L \leq 1$	3
		$0.05 < W$		-----	無 None
顯示區外 beyond A.A.	-----	忽略 Ignore			
IV. 軟板 Film	1. 尺寸 Dimension	軟板尺寸超規。 Film dimension out of Spec.	主要 Major		
	2. 損傷 Damage	破損；深刮傷；深摺痕；深壓痕或其他損害是不能接受的。 Crack; deep scratch; deep fold; deep pressure mark or other damage is not acceptable.	次要 Minor		
	3. 異物 Foreign material	導電異物附著在導線，軟板和玻璃之間的異物是不能接受的。 Conductive foreign material sticking to the leads, foreign material between film and glass are not acceptable.	次要 Minor		

14. APPENDIXES

APPENDIX 1: DEFINITIONS

A. DEFINITION OF CHROMATICITY COORDINATE

The chromaticity coordinate is defined as the coordinate value on the CIE 1931 color chart for R, G, B, W.

B. DEFINITION OF CONTRAST RATIO

The contrast ratio is defined as the following formula:

$$\text{Contrast Ratio} = \frac{\text{Luminance of all pixels on measurement}}{\text{Luminance of all pixels off measurement}}$$

C. DEFINITION OF RESPONSE TIME

The definition of turn-on response time T_r is the time interval between a pixel reaching 10% of steady state luminance and 90% of steady state luminance. The definition of turn-off response time T_f is the time interval between a pixel reaching 90% of steady state luminance and 10% of steady state luminance. It is shown in Figure 2.

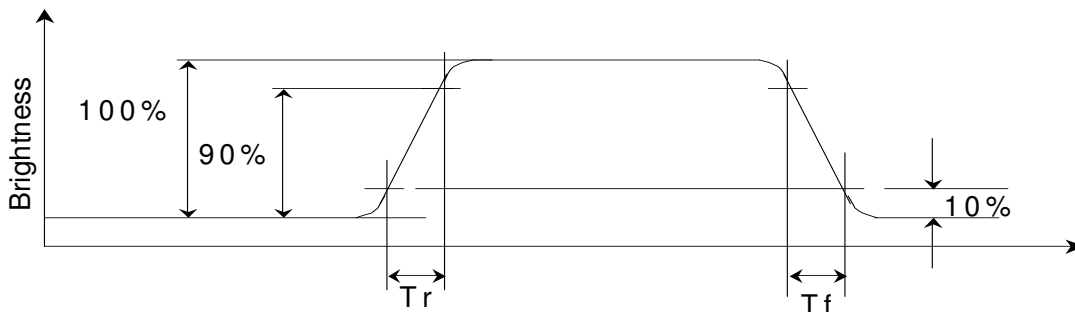

Figure 2: Response time

D. DEFINITION OF VIEWING ANGLE

The viewing angle is defined as Figure 3. Horizontal and vertical (H & V) angles are determined for viewing directions where luminance varies by 50% of the perpendicular value.

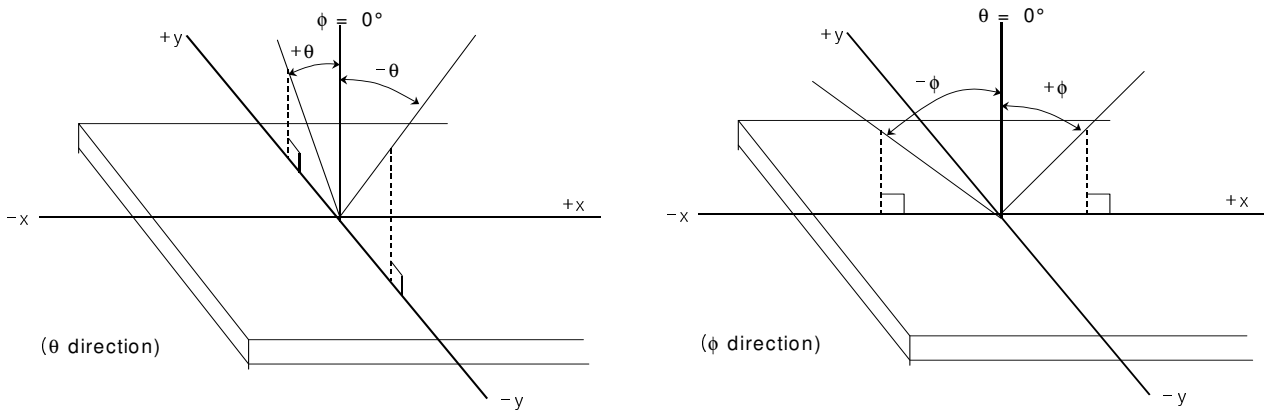
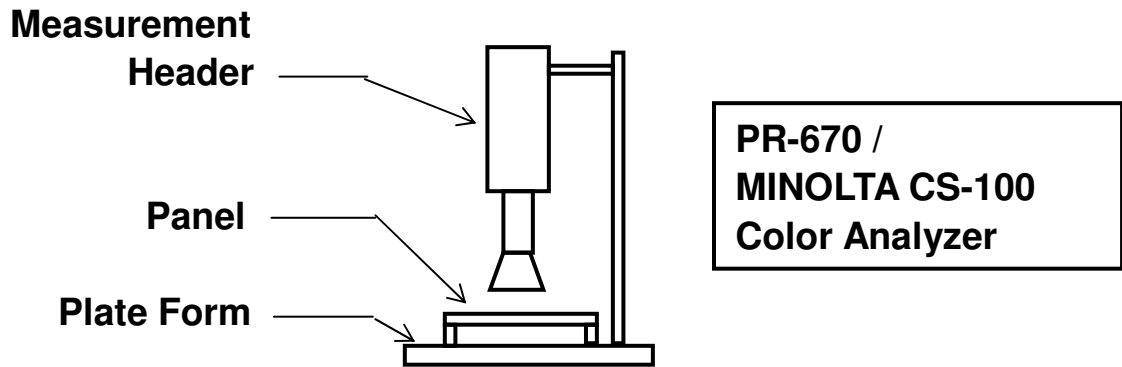

Figure 3: Viewing Angle

APPENDIX 2: MEASUREMENT APPARATUS

A. LUMINANCE/COLOR COORDINATE

PHOTO RESEARCH PR-670, MINOLTA CS-100



B. CONTRAST / RESPONSE TIME / VIEW ANGLE

WESTAR CORPORATION FPM-510

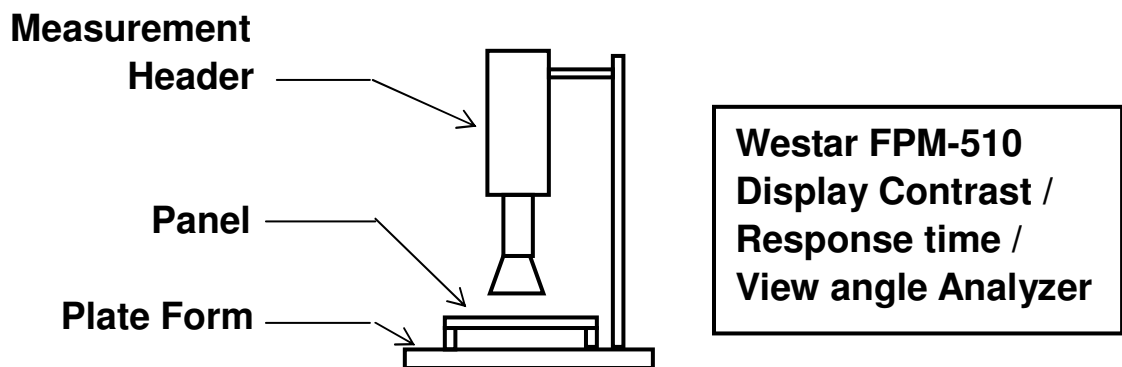

C. ESD ON AIR DISCHARGE MODE

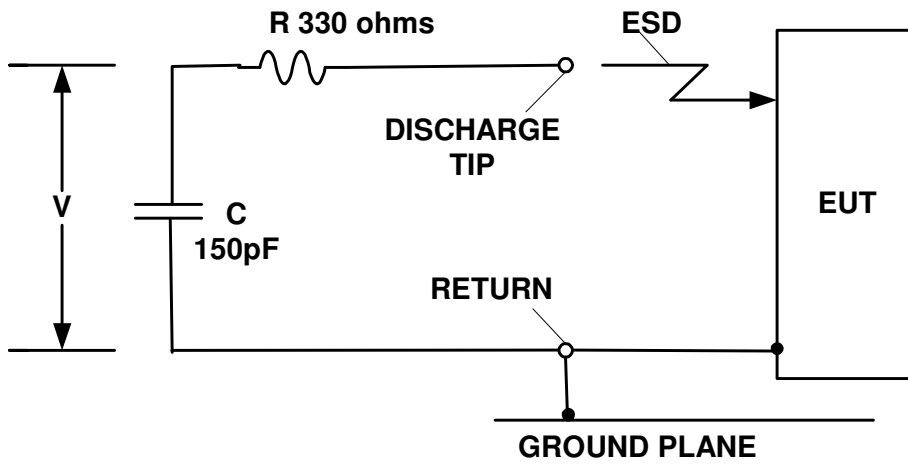

APPENDIX 3: PRECAUTIONS FOR USING THE OLED MODULE

Precautions for Handling

1. When handling the module, wear powder-free antistatic rubber finger cots, and be careful not to bend and twist it.
2. The OLED module is consisted of glass and film, and it should avoid pressure, strong impact, or being dropped from a high position.
3. The OLED module is an electronic component and is subject to damage caused by Electro Static Discharge (ESD). And hence normal ESD precautions must be taken when handling it. Also, appropriate ESD protective environment must be administered and maintained in the production line. When handling and assembling the panel, wear an antistatic wrist strap with the alligator clip attached to the ground to prevent ESD damage on the panel. Antistatic wrist strap should touch human body directly instead of gloves. (See below photos).

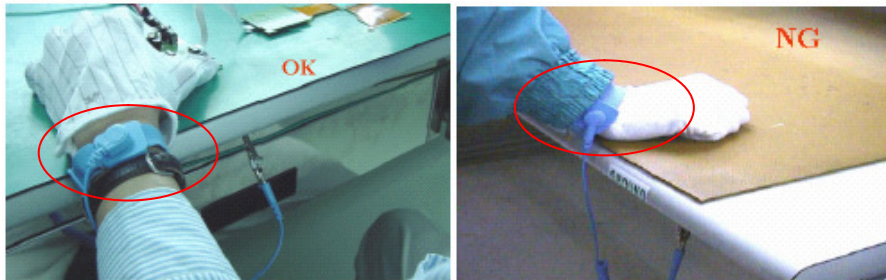

4. Take out the panel one by one from the holding trays for assembly, and never put the panel on top of another one to avoid the scratch.
5. Avoid jerk and excessive bend on TAB/FPC/COF, and be careful not to let foreign matter or bezel damage the film.
6. When handling and assembling the module (panel + IC), grab the panel, not the TAB/FPC/COF.
7. Use the tweezers to open the clicks on the connector of PCB before the insertion of FPC/COF, and click them back in. Once the FPC/COF sits properly in the connector, use the tweezers to avoid the damages.



8. Please do not bend the film near the substrate glass. It could cause film peeling and TAB/FPC/COF damage. For TAB, It should bend the slit area as actual OLED it is. For FPC or COF, it is suggested to follow below pictures for instruction (distance between substrate glass and bending area >1.5mm; R>0.5mm).

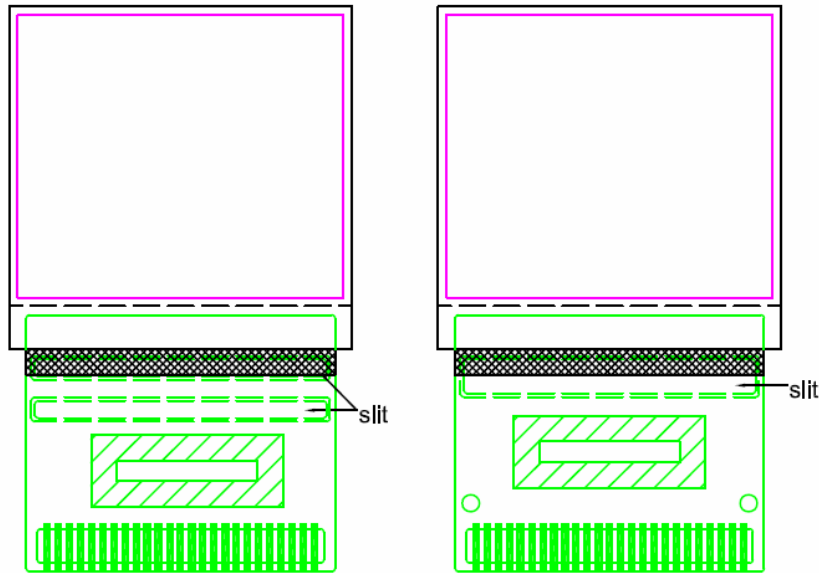

TAB

TAB

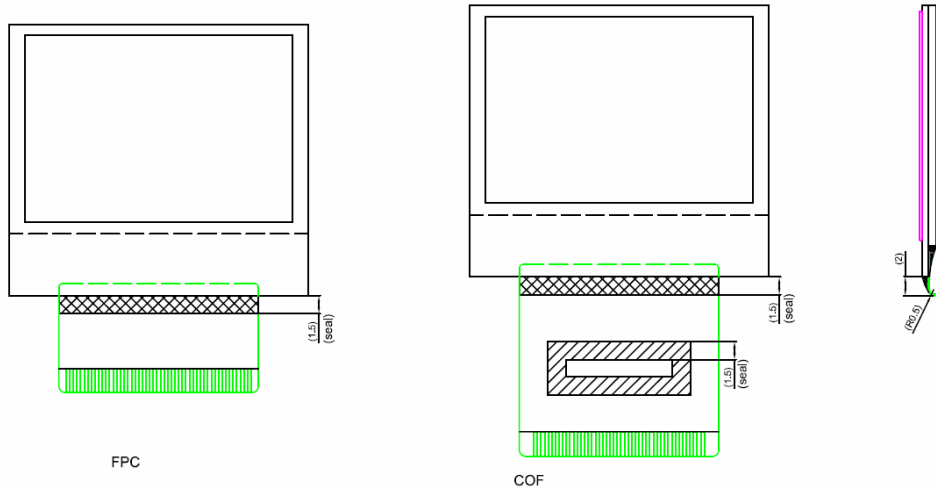

FPC

COF

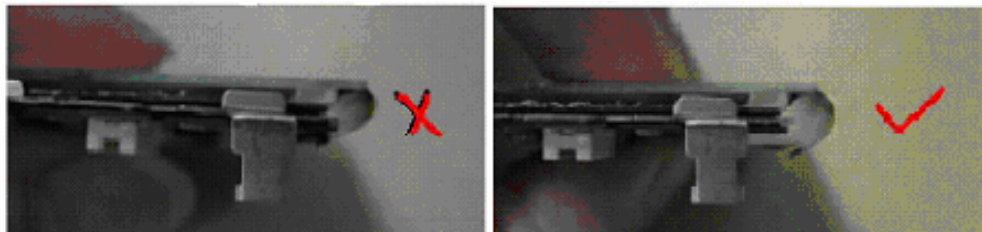

- Avoid bending the film at IC bonding area. It could damage the IC ILB bonding. It should avoid bending the IC seal area. Please keep the bending distance >1.5mm.

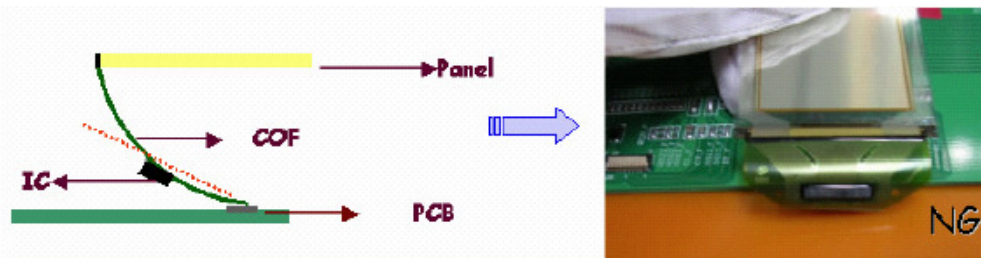
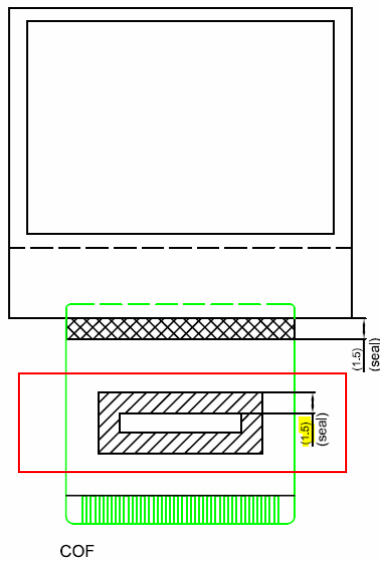

- Use both thumbs to insert COF into the connector when assembling the panel. Please refer to the photo.

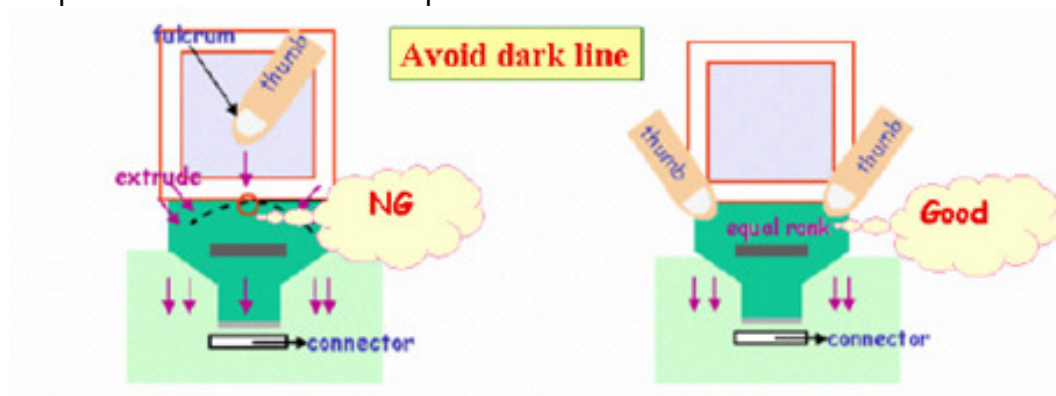

11. Do not wipe the pin of film and polarizer with the dry or hard materials that will damage the surface. When cleaning the display surface, use the soft cloth with solvent, IPA or alcohol, to clean.
12. Protection film is applied to the surface of OLED panel to avoid the scratch. Please remove the protective film before assembling it. If the OLED panel has been stored for a long time, the residue adhesive material of the protective film may remain on the display surface after remove the protective film. Please use the soft cloth with solvent, IPA or alcohol, to clean.
13. When hand or hot-bar soldering TAB/FPC onto PCB, make sure the temperature and timing profiles to meet the requirements of soldering specification (the specification depends on the application or optimized by customer) to prevent the damage of IC pins by inappropriate soldering.
14. Solder residues arise from soldering process have to be cleaned up thoroughly before the module assembly.
15. Use the voltage and current settings listed in the specification to do the function test after the module assembly.
16. Suggestion for soldering process:
 - i. TAB Lead- free soldering hot bar process
 1. Use pulse heated bonding tool equipment
 2. Material: Sn/Ag/Cu lead-free solder paste with typical 25um thickness on PCB pad. The TAB pin size and shape may be different, please base on the production line to adjust the thickness of PCB pad and temperature.
 3. Bonding Force:--4kg per centimeter square as the starting point.
 4. Suggested bonding tool temperature & time profile is as below for reference. Since there are differences in TAB soldering pins, soldering technicians' skills, mechanism...etc., the soldering conditions must be adequately tuned.

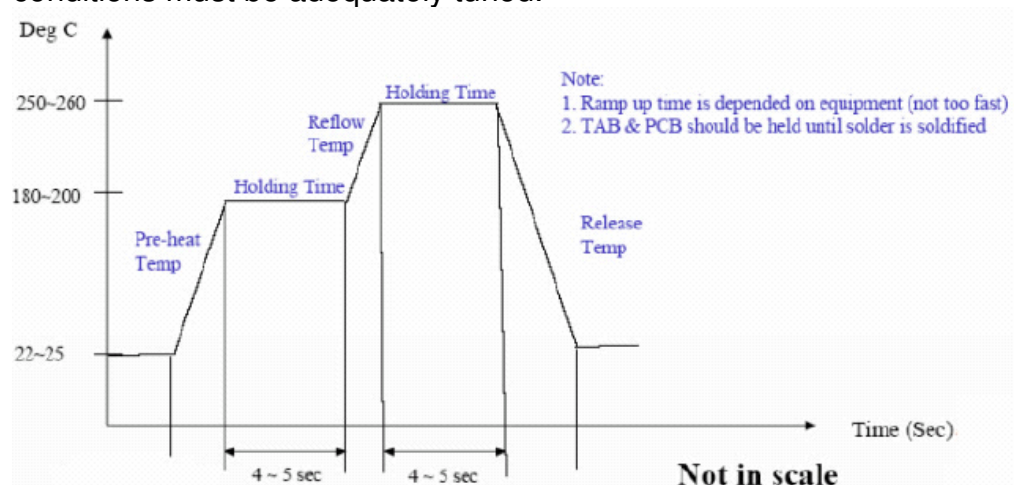

- ii. TAB Lead- free soldering wire process
 - In case of manual soldering (Lead- free solder wire)
 - 1. Solder wire contact iron directly: $280\pm 5^{\circ}\text{C}$ at 3-5secs
 - 2. Solder wire contact TAB lead directly (near iron but not contact): $380\pm 5^{\circ}\text{C}$, 3-5secs
 - 3. Since there are differences in TAB soldering pins, soldering technicians' skills, mechanism...etc., the soldering conditions must be adequately tuned.
- iii. High temperature will result in rapid heat conduction to IC and might cause damage to IC, so please keep the temperature below 380°C . Also, avoid damaging the polyimide and solder resist which might take place at high temperatures. Refold cycles base on the de-soldering status, if the plating of pin was damaged, it can not be used again.

Precautions for Electrical

1. Design using the settings in the specification

It is very important to design and operate the panel using the settings listed in the specification. It includes voltage, current, frame rate and duty cycle... etc. Operation the OLED outside the range of the specification should be entirely avoided to ensure proper operation of the OLED.

2. Maximum Ratings

To ensure the proper operation of the panel, never design the panel with parameters running over the maximum ratings listed in the specification. Also the logic voltages such as VIL and VIH have to be within the specified range in the specification to prevent any improper operation of the panel.

3. Power on/off procedure

To avoid any inadvertent effects resulting from inappropriate power on/off operations, please follow the directions of power on/off procedure on page 6. Any operation that does not comply with the procedure could cause permanent damage of the IC and should be avoided. When the logic power is not on, do not activate any input signal. Abrupt shutdown of power to the module, while the OLED panel is on, would cause OLED panel malfunction.

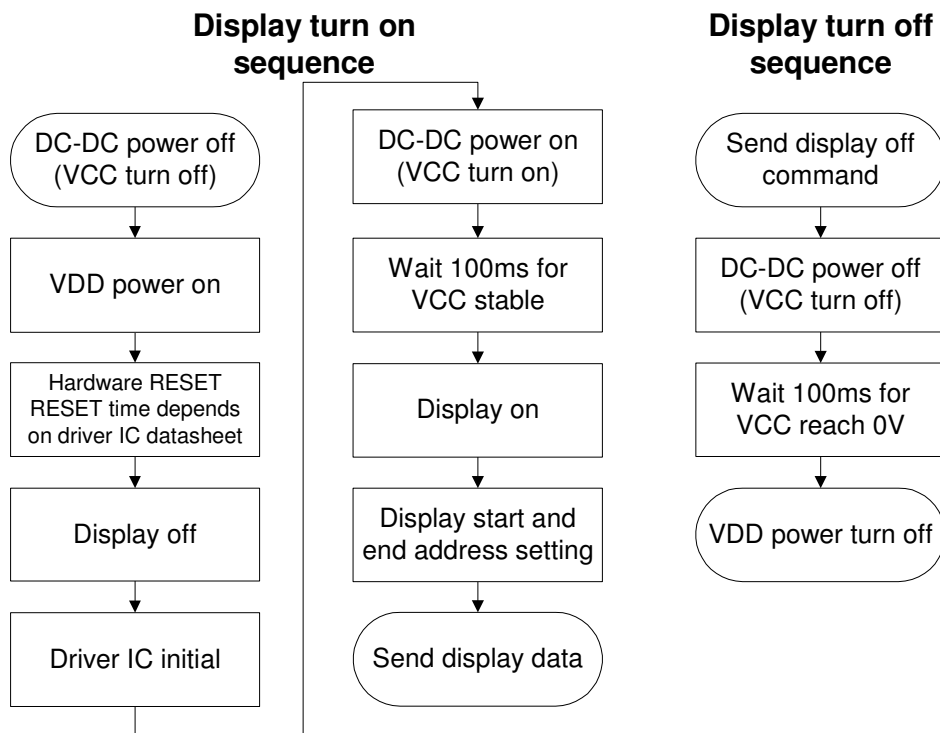

4. Power savings

To save power consumption of the OLED, please use partial display or sleep mode when the panel is not fully activated. Also, if possible, make the black background to save power.

The OLED is a self-luminous device and a particular pixel cluster or image can be lit on via software control. So power savings can be achieved by partial display or dimming down the luminance. Depending on the application, the user can choose among Ultra Bright Mode, Normal Operation Mode, and Sleeping Mode. The power consumption is almost in directly proportion to the brightness of the panel, and also in directly proportion to the number of pixels lit on the panel. The customer can save the power by the use of black background and sleeping mode. One benefit from using these design schemes is the extension of the OLED lifetime.

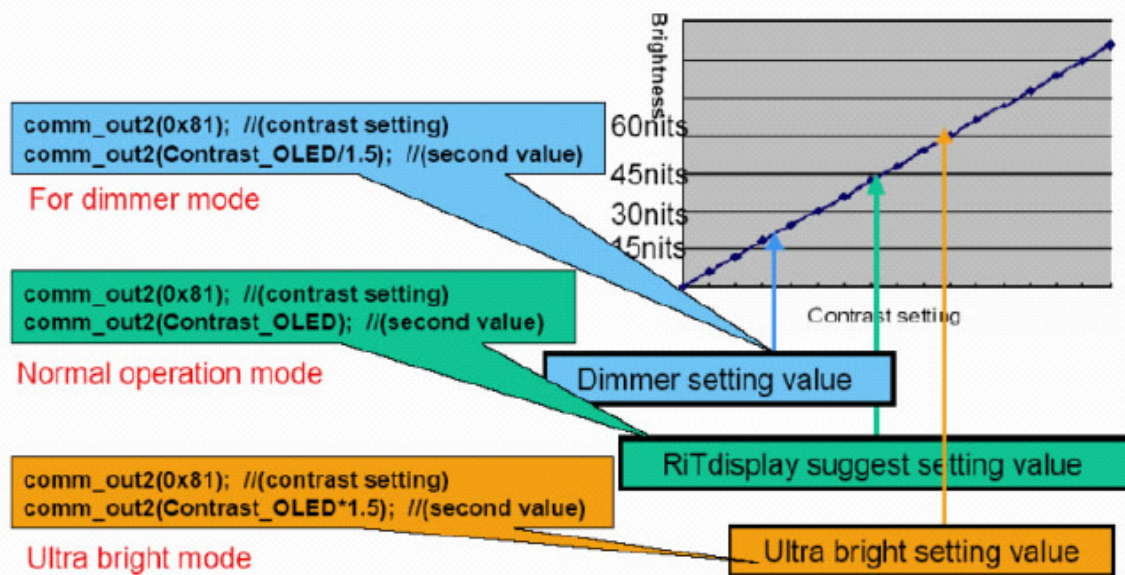

5. Adjusting the luminance of the panel

Although there are a couple of ways to adjust the luminance of the panel, it is strongly recommended that the customer change the contrast setting to adjust the luminance of the panel. Adjusting voltages to achieve desired luminance is not allowed. Be aware that the adjustment of luminance would accompany the change of lifetime of the panel and its power consumption as well.

6. Residual Image (Image Sticking)

The OLED is a self-emissive device. As with other self-emissive device or displays consisting of self-emissive pixels, when a static image frozen for a long period of time is changed to another one with all-pixels-on background, residual image or image sticking is noticed by the human eye. Image sticking is due to the luminance difference or contrast between the pixels that were previously turned on and the pixels that are newly turned on. Image sticking depends on the luminance decay curve of the display. The slower the decay, the less prominent the image sticking is. It is strongly recommended that the user employ the following four strategies to minimize image sticking.

1. Employ image scrolling or animation to even out the lit-on time of each and every pixel on the display, also could use sleeping mode for reduced the residual image and extend the power capacity.
2. Minimize the use of all-pixels-on or full white background in their application because when the panel is turned on full white, the image sticking from previously shown patterns is the most revealing. Black background is the best for power savings, greatest visibility, eye appealing, and dazzling displays.
3. Avoid displaying the characters or menu with high brightness level in a fix position for a long time or repeatedly. If necessary, using the auto fadeout technology.
4. If a static logo is used in the reliability test, change the pattern into its inverse (i.e., turn off the while pixels and turn on the previously unlit pixels) and freeze the inverse pattern as long as the original logo is used, so every pixel on the panel can be lit on for about the same time to minimize image sticking, caused by the differential turn-on time between the original and its reverse patterns.



Scrolling example

```

Example: setup and start
comm_out2(0x26); // scrolling setup
comm_out2(0x08); // scrolling numbers/step
comm_out2(0x00); // start page
comm_out2(0x00); // scrolling step/frame
comm_out2(0x08); // end page
comm_out2(0x2F); // start

Example: stop
comm_out2(0x2E); //stop
    
```

Precautions for Mechanical

1. Cushion or Buffer tape on the cover glass

It is strongly recommended to have a cushion or buffer tape to apply on the panel backside and front side when assembling OLED panel into module to protect it from damage due to excessive extraneous forces.

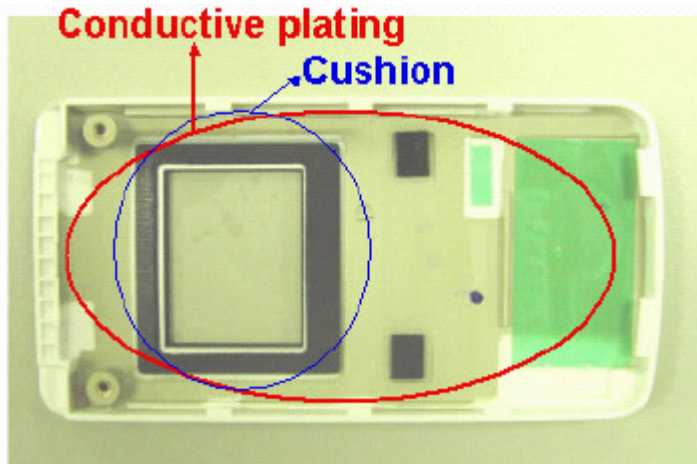

It is recommended that a plating conductive layer be used in the housing for EMI/EMC protection. And, the enough space should be reserved for the IC placement if the IC thickness is thicker than the TAB film when customer design the PCB.

2. Avoid excessive bending of film when handling or designing the panel into the product

The bending of TAB/COF/FPC has to follow the precautions indicated in the specification, extra bending or excessive extraneous forces should be avoided to minimize the chances of film damage. If bending the film is necessary, please bend the designated bending area only. Please refer to items 8 and 9 of Precautions for Handling for more information.

Precautions for Storage and Reliability Test

1. Storage

Store the packed cartons or packages at $25^{\circ}\text{C}\pm 5^{\circ}\text{C}$, $55\%\pm 10\%\text{RH}$. Do not store the OLED module under direct sunlight or UV light. For best panel performance, unpack the cartons and start the production of the panels within six months after the reception of them.

2. Reliability Test

RiTdisplay only guarantees the reliability of the OLEDs under the test conditions and durations listed in the specification.