

# Fully Configurable 8-Bit I<sup>2</sup>C-Controlled GPIO Expander

## FXL6408

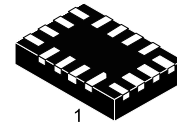

UQFN16  
CASE 523BF

### Description

The FXL6408 is an 8-bit I<sup>2</sup>C-controlled GPIO expander. When configured in Input Mode, the FXL6408 monitors the input ports for data transitions and signals the baseband by asserting the  $\overline{INT}$  pin. The input default values can be programmed independently, allowing customized input detection. All inputs can be configured with pull-up or pull-down resistors to pre-bias the inputs in open-drain or non-driven applications. When configured in Output Mode, the GPIO pins are capable of delivering 6 mA output drive according to the I<sup>2</sup>C register set. The FXL6408 is designed to allow voltage translation from levels as low as 1.65 V and up to 4.0 V. The FXL6408 features an active LOW RESET input as well as Power-On Reset (POR) circuit and I<sup>2</sup>C software reset options.

### Features

- 4X Expansion of Connected Processor I/O Ports
- Fully Integrated I<sup>2</sup>C Slave
- 8 Independently Configurable I/O Ports
- Low-Power Quiescent Current: 1.5  $\mu$ A
- Voltage Translation Capable from 1.65 V I<sup>2</sup>C Port Up to 4.0 V GPIO Pins
- Selectable Device Address
- 6 mA Output Drive
- Interrupt Pin to Alert Processor of Status Changes

### MARKING DIAGRAM

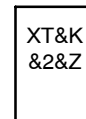

XT	= FXL6408 Device Code
&K	= Lot Trace Code
&2	= Two Digit Date Code
&Z	= Assembly Plant Code

### ORDERING INFORMATION

See detailed ordering and shipping information on page 12 of this data sheet.

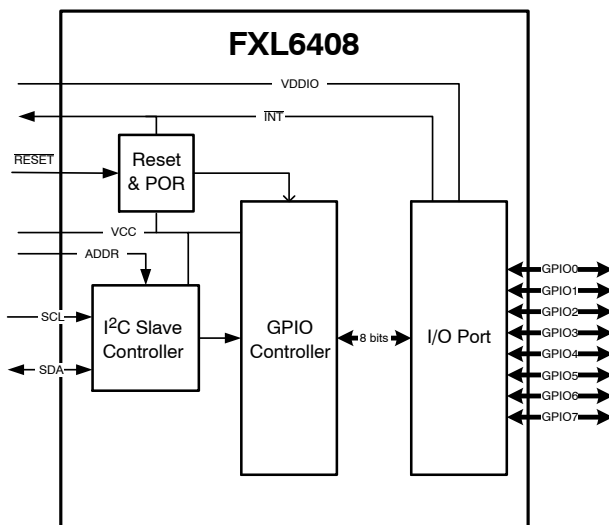

Figure 1. FXL6408 Block Diagram

# FXL6408

## PIN CONFIGURATION

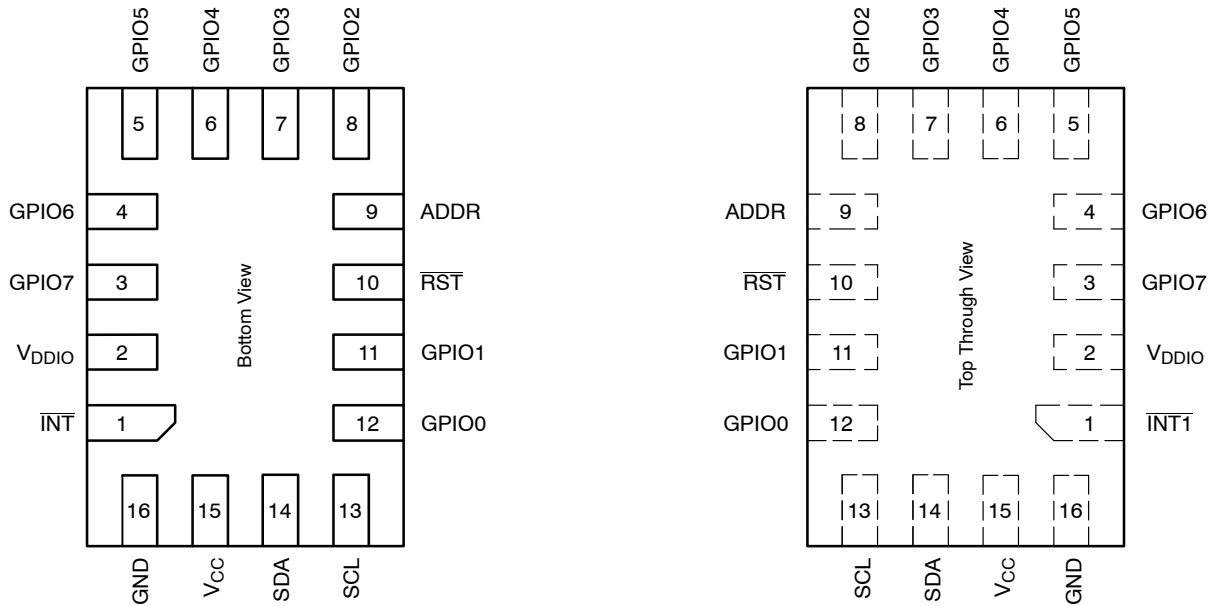

Figure 2. FXL6408 Pin Assignment (Top Through and Bottom Views)

Table 1. PIN DESCRIPTIONS

Pin No.	Pin Name	Description
1	INT	Interrupt Output, Open-Drain, Active LOW; Requires an External Pull-Up Resistor to V <sub>CC</sub>
2	V <sub>DDIO</sub>	Voltage Reference for I/O-Side Voltage Translation (if I/O Translation is not needed, tie V <sub>DDIO</sub> to the V <sub>CC</sub> supply)
3	GPIO7	General-Purpose Programmable I/O
4	GPIO6	General-Purpose Programmable I/O
5	GPIO5	General-Purpose Programmable I/O
6	GPIO4	General-Purpose Programmable I/O
7	GPIO3	General-Purpose Programmable I/O
8	GPIO2	General-Purpose Programmable I/O
9	ADDR	Address Input, GND or V <sub>CC</sub>
10	$\overline{\text{RST}}$	Reset Input, Active LOW, Requires a pull-Up Resistor to V <sub>CC</sub>
11	GPIO1	General-Purpose Programmable I/O
12	GPIO0	General-Purpose Programmable I/O
13	SCL	I <sup>2</sup> C Serial Bus; Requires a Pull-Up Resistor to V <sub>CC</sub>
14	SDA	I <sup>2</sup> C Serial Data; Requires a Pull-Up Resistor to V <sub>CC</sub>
15	V <sub>CC</sub>	Supply Voltage
16	GND	Ground

**Table 2. ABSOLUTE MAXIMUM RATINGS**

Symbol	Parameter	Condition	Min	Max	Unit
$V_{CC}, V_{DDIO}$	Supply Voltages		-0.5	4.6	V
$V_{IN}$	DC Input Voltage		-0.5	4.0	V
$V_{OUT}$	Output Voltage (Note 1)		-0.5	4.0	V
$I_{IK}$	DC Input Diode Current	$V_{IN} < 0\text{ V}$		-50	mA
$I_{OK}$	DC Output Diode Current	$V_{OUT} < 0\text{ V}$		-50	mA
$I_{OL}$	DC Output Sink Current			+50	mA
$I_{CC}$	DC $V_{CC}$ or Ground Current per Supply Pin			$\pm 100$	mA
$T_{STG}$	Storage Temperature Range		-65	+150	$^{\circ}\text{C}$
$T_J$	Junction Temperature under Bias			+150	$^{\circ}\text{C}$
$T_L$	Junction Lead Temperature, Soldering 10 seconds			+260	$^{\circ}\text{C}$
$\theta_{JA}$	Thermal Resistance, Junction-to-Ambient			115	$^{\circ}\text{C}/\text{W}$
ESD	Electrostatic Discharge Capability	Human Body Model, JESD22-A114		4	kV
		Charged Device Model, JESD22-C101		2	

Stresses exceeding those listed in the Maximum Ratings table may damage the device. If any of these limits are exceeded, device functionality should not be assumed, damage may occur and reliability may be affected.

1. All output current absolute maximum ratings must be observed.

**Table 3. RECOMMENDED OPERATING CONDITIONS**

Symbol	Parameter	Condition	Min	Max	Unit
$V_{CC}$	Supply Voltage Operating		1.65	3.60	V
$V_{DDIO}$	I/O Side Reference Voltage		1.65	4.00	V
$V_{IN}$	Input Voltage on I/O Pins		0	4.00	V
$V_{OUT}$	Output Voltage		0	$V_{DDIO}$	V
$T_A$	Operating Temperature		-40	+85	$^{\circ}\text{C}$
$t_r, t_f$	Input Rise and Fall Times to I/O Pins when Configured as Inputs	$V_{DDIO}$ at 1.8 V, 2.5 V $\pm 0.2\text{ V}$	0	200	ns/V
		$V_{DDIO}$ at 3.6 V $\pm 0.3\text{ V}$	0	100	

Functional operation above the stresses listed in the Recommended Operating Ranges is not implied. Extended exposure to stresses beyond the Recommended Operating Ranges limits may affect device reliability.

# FXL6408

**Table 4. DC ELECTRICAL CHARACTERISTICS**

Symbol	Parameter	Condition	V <sub>CC</sub> (V)	T <sub>A</sub> = 25°C			T <sub>A</sub> = -40 to 85°C		Unit
				Min	Typ	Max	Min	Max	
<b>RST, ADDR, SDA, SCL, INT Pins</b>									
V <sub>POR</sub>	Power-On Reset Voltage	V <sub>DDIO</sub> = 0 to 4.0 V				1.25		1.25	V
I <sub>IN</sub>	Input Leakage Current	0 ≤ V <sub>IN</sub> ≤ V <sub>CC</sub>	0 to 3.6			±1		±10	μA
I <sub>OFF</sub>	Power-Off Leakage Current	V <sub>IN</sub> or V <sub>OUT</sub> = 3.6 V	0			1		10	μA
I <sub>CC</sub>	Standby Mode (SCL in Static Condition)	V <sub>IN</sub> = V <sub>CC</sub> or GND	1.8 to 3.6			1.2		1.5	μA
	Active Mode (SCL Active) (Note 2)					300		300	
<b>GPIO Pins</b>									
<b>V<sub>DDIO</sub> (V)</b>									
V <sub>IH</sub>	HIGH Level Input Voltage		1.65 to 1.95	0.65			0.65		V
			2.30 to 4.00	V <sub>DDIO</sub>			V <sub>DDIO</sub>		
V <sub>IL</sub>	LOW Level Input Voltage		1.65 to 1.95	-0.3		0.35	-0.3	0.35	V
			2.30 to 4.00	-0.3		0.30	-0.3	0.30	
V <sub>OH</sub>	HIGH Level Output Voltage	V <sub>IN</sub> = V <sub>IH</sub> , I <sub>OH</sub> = 100 μA	1.8	V <sub>DDIO</sub>			V <sub>DDIO</sub>		V
			3.6	V <sub>DDIO</sub>			V <sub>DDIO</sub>		V
			4.0	V <sub>DDIO</sub>			V <sub>DDIO</sub>		V
		I <sub>OH</sub> = 6 mA	1.8	V <sub>DDIO</sub>			V <sub>DDIO</sub>		V
			3.6	V <sub>DDIO</sub>			V <sub>DDIO</sub>		V
V <sub>OL</sub>	LOW Level Output Voltage	V <sub>IN</sub> = V <sub>IL</sub> , I <sub>OL</sub> = -100 μA	1.8			0.2		0.2	V
			3.6			0.2		0.2	
			4.0			0.2		0.2	
		I <sub>OL</sub> = -6 mA	1.8			0.45		0.45	
			3.6			0.5		0.5	
R <sub>PULL</sub>	Pull-Up or Pull-Down Resistors				100			kΩ	
I <sub>OL</sub>	Output Low Current		1.8 to 4.0	6.0			6.0		mA
I <sub>OH</sub>	Output High Current		1.8 to 4.0	-6.0			-6.0		mA
I <sub>IN</sub>	Input Low Current (Note 3)	0 ≤ V <sub>IN</sub> ≤ V <sub>DDIO</sub>	1.8 to 4.0			±50		±50	μA
I <sub>OFF</sub>	Power-Off Leakage Current	V <sub>IN</sub> = 4.0 V	0			1		10	μA

Product parametric performance is indicated in the Electrical Characteristics for the listed test conditions, unless otherwise noted. Product performance may not be indicated by the Electrical Characteristics if operated under different conditions.

2. Includes all internal circuitry consumption from the V<sub>CC</sub> supply. Does not include the I/O buffers, which are supplied by V<sub>DDIO</sub> and are load dependent.
3. I<sub>IL</sub> and I<sub>IH</sub> specifications only apply when the outputs are configured with pull-down or pull-up resistors, respectively. Specifications values assume V<sub>IN</sub> ≤ V<sub>DDIO</sub>.

# FXL6408

**Table 5. AC ELECTRICAL CHARACTERISTICS** (All typical values are for  $V_{CC} = 1.8\text{ V}$  at  $T_A = 25^\circ\text{C}$  unless otherwise specified.)

Symbol	Parameter	Fast Mode		Unit
		Min	Max	
$t_W$	Reset Pulse Duration (see Figure 3)	150		ns
$t_{RST\_GLITCH}$	Input Glitch Rejection on RST Pin (see Figure 3)	50	150	ns
$t_{RESET}$	Reset Time, Total Time from Rising Edge of Reset Pulse to Falling Edge of $\overline{INT}$ Pin (see Figure 4)		150	ns
$t_{IV}$	Time from Input Default State Change to $\overline{INT}$ Pin Driven LOW (see Figure 5)		4	$\mu\text{s}$

Product parametric performance is indicated in the Electrical Characteristics for the listed test conditions, unless otherwise noted. Product performance may not be indicated by the Electrical Characteristics if operated under different conditions.

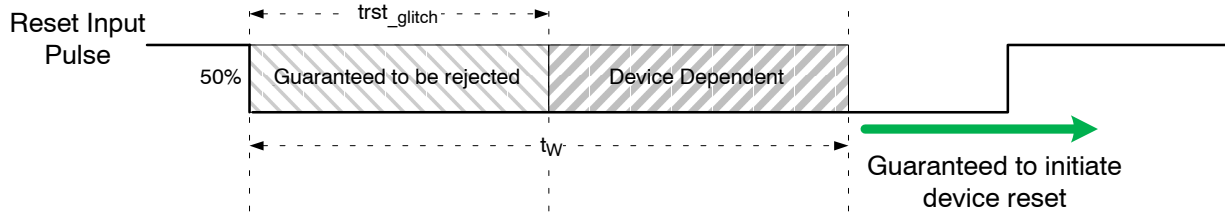

**Figure 3. Reset Pulse Duration and Input Glitch Rejection Timing Diagram**

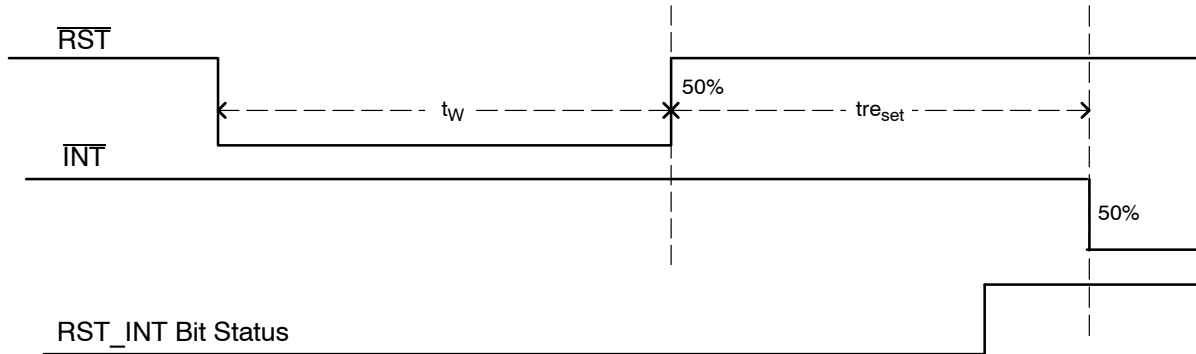

**Figure 4. Reset Time and Reset Pulse Timing Diagram**

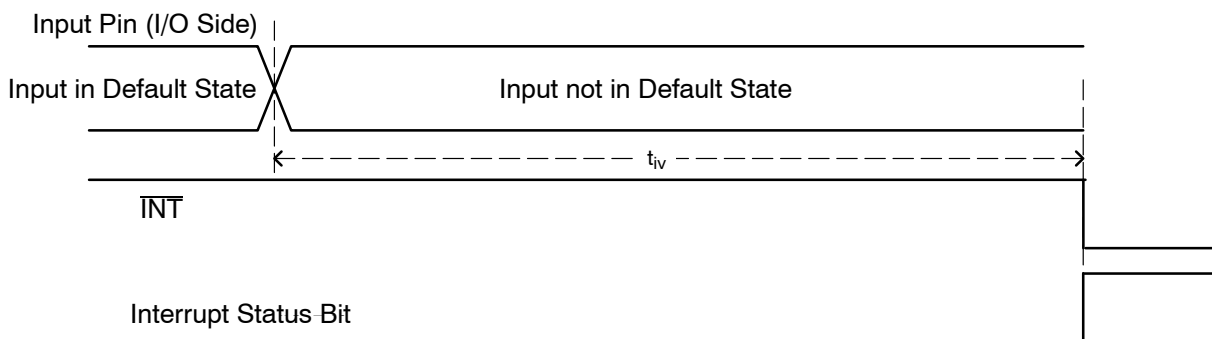

**Figure 5. Time to INT from Change in Input Default State**

# FXL6408

**Table 6. DC CHARACTERISTICS (I<sup>2</sup>C CONTROLLER SDA, SCL)**

Symbol	Parameter	Fast Mode (400 kHz)		
		Min	Max	Unit
V <sub>IL</sub>	Low-Level Input Voltage	-0.5	0.3 V <sub>CC</sub>	V
V <sub>IH</sub>	High-Level Input Voltage	0.7 V <sub>CC</sub>		V
V <sub>HYS</sub>	Hysteresis of Schmitt Trigger Inputs	V <sub>CC</sub> > 2 V	0.05 V <sub>CC</sub>	V
		V <sub>CC</sub> < 2 V	0.1 V <sub>CC</sub>	
V <sub>OL</sub>	Low-level Output Voltage at 3 mA Sink Current (Open-Drain or Open-Collector)	V <sub>CC</sub> > 2 V	0	V
		V <sub>CC</sub> < 2 V	0.2 V <sub>CC</sub>	
I <sub>I</sub>	Input Current of Each I/O Pin, Input Voltage 0.26 V to 2.34 V	-10	10	μA
C <sub>I</sub>	Capacitance for Each I/O Pin		10	pF

Product parametric performance is indicated in the Electrical Characteristics for the listed test conditions, unless otherwise noted. Product performance may not be indicated by the Electrical Characteristics if operated under different conditions.

**Table 7. AC ELECTRICAL CHARACTERISTICS** (All typical values are for V<sub>CC</sub> = 1.8 V at T<sub>A</sub> = 25°C unless otherwise specified.)

Symbol	Parameter	Fast Mode (400 kHz)		
		Min	Max	Unit
f <sub>SCL</sub>	SCL Clock Frequency	0	400	kHz
t <sub>HD;STA</sub>	Hold Time (Repeated) START Condition	0.6		μs
t <sub>LOW</sub>	LOW Period of SCL Clock (Note 4)	1.3		μs
t <sub>HIGH</sub>	HIGH Period of SCL Clock	0.6		μs
t <sub>SU;STA</sub>	Set Up Time for Repeated START Condition	0.6		μs
t <sub>HD;DAT</sub>	Data Hold Time (See Figure 6)	0	0.9	μs
t <sub>SU;DAT</sub>	Data Set Up Time (See Figure 6) (Note 5)	100		ns
t <sub>PS</sub>	Set Up Time Required by SDA Input Buffer (When Receiving Data)	0		ns
t <sub>PH</sub>	Out Delay Required by SDA Output Buffer (When Transmitting Data)	300		ns
t <sub>r</sub>	Rise Time of SDA and SCL Signals (Note 6, 7)	20 + 0.1C <sub>b</sub>	300	ns
t <sub>f</sub>	Fall Time of SDA and SCL Signals (Note 6, 7)	20 + 0.1C <sub>b</sub>	300	ns
t <sub>SU;STOP</sub>	Set Up Time for STOP Condition	0.6		μs
t <sub>BUF</sub>	Bus Free Time between a STOP and START Conditions	1.3		μs
t <sub>SP</sub>	Pulse Width of Spikes that Must Be Suppressed by the Input Filter	0	50	ns

Product parametric performance is indicated in the Electrical Characteristics for the listed test conditions, unless otherwise noted. Product performance may not be indicated by the Electrical Characteristics if operated under different conditions.

4. The FXL6408 can accept clock signals with LOW as low as 1.1 μs, provided that the received SDA signal t<sub>HD;DAT</sub> + t<sub>r/f</sub> ≤ 1.1 μs. The FXL6408 features a 0 ns SDA input setup time and, therefore, this parameter is not included in the above equation.
5. A Fast-Mode I<sup>2</sup>C-Bus<sup>®</sup> device can be used in a Standard-Mode I<sup>2</sup>C-Bus system, but the requirement t<sub>SU;DAT</sub> ≥ 250 ns must be met. This is automatically the case if the device does not stretch the LOW period of the SCL signal. If such a device does stretch the LOW period of the SCL signal. It must output the next data bit to the SDA line t<sub>r,max</sub> + t<sub>SU;DAT</sub> = 1000 + 250 = 1250 ns (according to the Standard-Mode I<sup>2</sup>C bus specification) before the SCL line is released.
6. C<sub>b</sub> equals the total capacitance of one bus line in pF. If mixed with High-Speed Mode devices, faster fall times are allowed, according to the I<sup>2</sup>C specification.
7. The FXL6408 ensures that the SDA signal out must coincide with SCL LOW for worst-case SCL t<sub>f</sub> maximum times of 300 ns. This requirement prevents data loss by preventing SDA out transitions during the undefined region of the falling edge of SCL. Consequently, the FXL6408 fulfils the following requirement from the I<sup>2</sup>C specification, note 2 on page 77: "A device must internally provide a hold time of at least 300 ns for the SDA signal (referred to the V<sub>IHmin</sub> of the SCL signal) to bridge the undefined region of the falling edge of SCL."
8. FXL6408 I<sup>2</sup>C slave is fully compliant the NXP (Phillips) I<sup>2</sup>C specification Rev. 0.3 UM10204 (2007).

DEFINITION OF TIMING

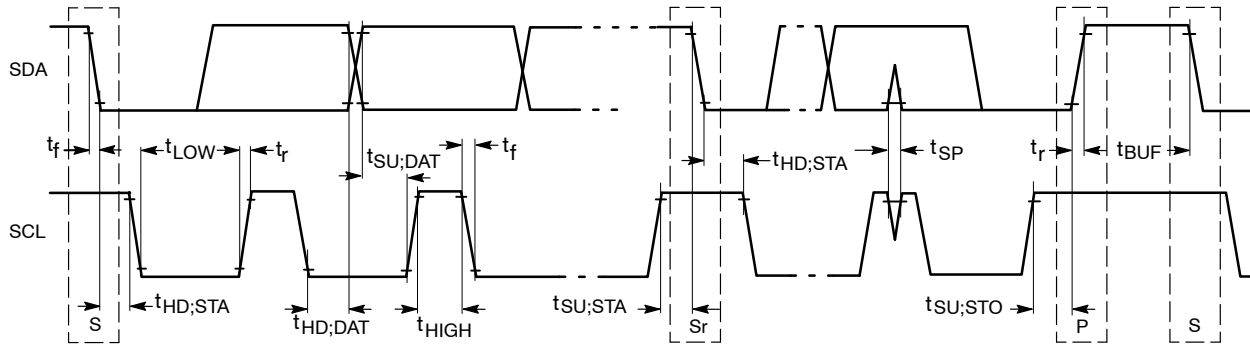

Figure 6. Definition of Timing for Full-Speed Mode Devices on the I<sup>2</sup>C Bus

FUNCTIONAL DESCRIPTION

Overview

The FXL6408 I/O expander frees up six ports of the central processor to be dedicated for more critical functions. The FXL6408 enables the addition of eight General-Purpose Input / Output (GPIO) ports to a system processor while using two I/O ports for I<sup>2</sup>C control (net six additional I/Os). The device can be used in multiple applications, from button monitoring to driving control pins of other ICs in the system. It also allows the system designer to add new features and functions quickly without upgrading the central processor. The FXL6408 includes eight I/O pins controlled by an integrated I<sup>2</sup>C slave and allows the central processor to control each I/O independently. When configured as outputs, each pin can deliver up to 6 mA drive. When configured as inputs, the default state can be independently configured. In addition, the FXL6408 has integrated pull-up and pull-down resistors that are enabled via I<sup>2</sup>C commands in the register map. This allows the system designer to pre-bias the inputs to a known level to allow use with un-driven input signals.

Interrupt Operation

The  $\overline{\text{INT}}$  pin is a LOW-asserted open-drain output and requires an external pull-up resistor. The FXL6408 signals an interrupt to the processor when an event occurs, removing the need for the processor to continuously poll the FXL6408 registers. Immediately after detecting a change at an input, the FXL6408 writes the corresponding bit in the input interrupt status register (13<sub>h</sub>) and asserts the  $\overline{\text{INT}}$  pin by pulling it LOW. The interrupt status register bit remains HIGH until the processor reads the register and clears the bit. If the input pin remains in the non-default state after the interrupt has been serviced, a new interrupt is not generated until after the input state has first returned to its default state and changed back to its non-default state. The FXL6408 also contains an Input Status register (0F<sub>h</sub>) used to verify the current status of the given input at the time when the

interrupt is serviced by the processor. These two registers allow the processor to determine the following information about any input every time the register map is read:

- If the input state changed from the default state since the most recent register read; and
- The current state of the input pin.

The interrupt output  $\overline{\text{INT}}$ , once asserted, is held LOW until the interrupt is serviced by the processor. This means that the system uses level-sensitive interrupts. Interrupt signaling is asynchronous to the SCL signal.

Device Reset

The FXL6408 has three reset options, all of which cause the part to reset all register settings to their default states. Immediately after device reset, the RST\_INT bit in the Device ID & Ctrl register (01<sub>h</sub>) is HIGH and an interrupt signal is generated by the FXL6408. After the processor reads the register, this bit is cleared and, on future register reads, the processor can verify that the FXL6408 has not been reset if this bit remains LOW. Following are descriptions of the three reset methods.

Power-On Reset (POR)

On device power-up, when V<sub>CC</sub> reaches V<sub>POR</sub> or if the V<sub>CC</sub> supply voltage drops below V<sub>POR</sub> during operation, the FXL6408 immediately resets.

Software Reset

The FXL6408 can be reset by the processor using an I<sup>2</sup>C write command to change bit 0 of register 01<sub>h</sub> to a 1. Immediately following this change, the FXL6408 resets and all register values return to their default values. In this case, the SW\_RST bit returns to 0 as soon as the reset sequence is completed.

Reset Pin

The FXL6408 is reset when the  $\overline{\text{RST}}$  pin (C3) is pulled LOW.

# FXL6408

## Translation

The FXL6408 has the ability to translate between the system I<sup>2</sup>C voltage reference and the I/O voltage reference. The V<sub>CC</sub> pin is used both as the FXL6408 power supply as well as the voltage reference for the I<sup>2</sup>C inputs, ADDR,  $\overline{\text{INT}}$  and RESET pins. The V<sub>DDIO</sub> pin is used only for the voltage supply reference of the I/O ports. For example, a 1.8 V-referenced I<sup>2</sup>C Bus can be used to interface with the FXL6408 and control 3.6 V-referenced I/Os by supplying V<sub>CC</sub> = 1.8 V and V<sub>DDIO</sub> = 3.6 V. If translation

is not needed, the system provides the same voltage to both the V<sub>CC</sub> and V<sub>DDIO</sub> pins. If both the I/O and I<sup>2</sup>C interfaces are referenced to 1.8 V, the V<sub>CC</sub> supply and V<sub>DDIO</sub> pin should both be tied to 1.8 V.

## I<sup>2</sup>C Read / Write Procedures

Figure 7 and Figure 8 illustrate compatible I<sup>2</sup>C write and read sequences. The FXL6408 does not support burst read or write optional modes described in the I<sup>2</sup>C standard.



**Figure 7. I<sup>2</sup>C Write Sequence**

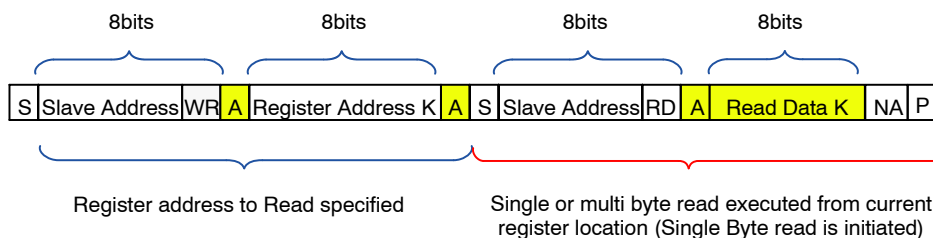

NOTE: If Register is not specified the Master reads from the current register.

	From Master to Slave	<b>S</b> Start Condition	<b>NA</b> NOT Acknowledge (SDA high)	<b>RD</b> Read = 1
	From Slave to Master	<b>A</b> Acknowledge (SDA Low)	<b>WR</b> Write=0	<b>P</b> Stop Condition

**Figure 8. I<sup>2</sup>C Read Sequence**

**Table 8. I<sup>2</sup>C ADDRESS**

Name	ADDR Pin	Bit 7	Bit 6	Bit 5	Bit 4	Bit 3	Bit 2	Bit 1	Bit 0
Device Address	ADDR = 0	1	0	0	0	0	1	1	WR
	ADDR = 1	1	0	0	0	1	0	0	WR



# FXL6408

**Table 9. I<sup>2</sup>C REGISTER MAP**

Register	Address	Type	Bit7	Bit6	Bit5	Bit4	Bit3	Bit2	Bit1	Bit0	Reset Value
Device ID & Ctrl	01h	R/W	MF3	MF2	MF1	FW_rev3	FW_rev2	FW_rev1	RST_INT	SW_RST	10100010
IO Direction	03h	R/W	GPIO7	GPIO6	GPIO5	GPIO4	GPIO3	GPIO2	GPIO1	GPIO0	00000000
Output State	05h	R/W	Out 7	Out 6	Out 5	Out 4	Out 3	Out 2	Out 1	Out 0	00000000
Output High-Z	07h	R/W	Out 7	Out 6	Out 5	Out 4	Out 3	Out 2	Out 1	Out 0	11111111
Input Default State	09h	R/W	In 7	In 6	In 5	In 4	In 3	In 2	In 1	In 0	00000000
Pull Enable	0Bh	R/W	In 7	In 6	In 5	In 4	In 3	In 2	In 1	In 0	11111111
Pull-Down/ Pull-Up	0Dh	R/W	In 7	In 6	In 5	In 4	In 3	In 2	In 1	In 0	00000000
Input Status	0Fh	R	In 7	In 6	In 5	In 4	In 3	In 2	In 1	In 0	XXXXXXXX
Interrupt Mask	11h	R/W	In 7	In 6	In 5	In 4	In 3	In 2	In 1	In 0	00000000
Interrupt Status	13h	R/W	In 7	In 6	In 5	In 4	In 3	In 2	In 1	In 0	XXXXXXXX
Reserved	02h, 04h, 06h, 08h, 0Ah, 0Ch, 0Eh, 10h, 12h	Reserved	XXXXXXXX								

**Table 10. DEVICE ID & CONTROL** (Address 01<sub>h</sub>; RST INT flag is cleared after being read by master; for SW reset, the master writes bit 0 HIGH)

Bit #	Name	Bit Size	Description
7:5	MF	3	3-bit manufacturer ID assigned by Nokia, Bits 7:5 are 101 for <b>onsemi</b> .
4:2	FW_rev	3	3-bit ascending value, indicating the firmware revision. Initial revision is 000.
1	RST_INT	1	Indicates that the device has been reset and the default values are set. 0: normal operation 1: the device has been reset and register default values are set
0	SW_RST	1	Software reset: 0: normal operation 1: SW reset commanded

**Table 11. IO DIRECTION** (Address 03<sub>h</sub>)

Bit #	Name	Bit Size	Description
7	GPIO7	1	0: GPIO configured as Input 1: GPIO configured as Output
6	GPIO6	1	
5	GPIO5	1	
4	GPIO4	1	
3	GPIO3	1	
2	GPIO2	1	
1	GPIO1	1	
0	GPIO0	1	

## FXL6408

**Table 12. OUTPUT STATE** (Address 05<sub>h</sub>; if the pin is defined as input in register 03<sub>h</sub>, the corresponding bit has no effect)

Bit #	Name	Bit Size	Description
7	Out 7	1	0: GPIO Output = LOW 1: GPIO Output = HIGH
6	Out 6	1	
5	Out 5	1	
4	Out 4	1	
3	Out 3	1	
2	Out 2	1	
1	Out 1	1	
0	Out 0	1	

**Table 13. OUTPUT HIGH-Z** (Address 07<sub>h</sub>; if the pin is defined as input in register 03<sub>h</sub>, the corresponding bit has no effect)

Bit #	Name	Bit Size	Description
7	Out 7	1	0: GPIO Output state follows register 05 <sub>h</sub> 1: GPIO Output = HIGH-Z
6	Out 6	1	
5	Out 5	1	
4	Out 4	1	
3	Out 3	1	
2	Out 2	1	
1	Out 1	1	
0	Out 0	1	

**Table 14. INPUT DEFAULT STATE** (Address 09<sub>h</sub>; defines the expected state of the GPIO; if the pin is defined as output in register 03<sub>h</sub>, the corresponding bit has no effect)

Bit #	Name	Bit Size	Description
7	In 7	1	0: GPIO input default is set to LOW; when the GPIO goes HIGH, an interrupt is triggered 1: GPIO input default is set to HIGH; when the GPIO goes LOW, an interrupt is triggered
6	In 6	1	
5	In 5	1	
4	In 4	1	
3	In 3	1	
2	In 2	1	
1	In 1	1	
0	In 0	1	

## FXL6408

**Table 15. PULL ENABLE** (Address 0B<sub>n</sub>; pull enable for input pin; if the pin is defined as output in register 03<sub>n</sub>, the corresponding bit has no effect)

Bit #	Name	Bit Size	Description
7	In 7	1	0: GPIO input Pull-up/Pull-down is not enabled 1: GPIO input Pull-up/Pull-down is enabled
6	In 6	1	
5	In 5	1	
4	In 4	1	
3	In 3	1	
2	In 2	1	
1	In 1	1	
0	In 0	1	

**Table 16. PULL-DOWN / PULL-UP** (Address 0D<sub>n</sub>; if the pin is defined as output in register 03<sub>n</sub>, the corresponding bit has no effect; if the corresponding bit in register 0B<sub>n</sub>=0, this register setting has no effect)

Bit #	Name	Bit Size	Description
7	In 7	1	0: GPIO input Pull-down is enabled 1: GPIO input Pull-up is enabled
6	In 6	1	
5	In 5	1	
4	In 4	1	
3	In 3	1	
2	In 2	1	
1	In 1	1	
0	In 0	1	

**Table 17. INPUT STATUS** (Address 0F<sub>n</sub>; if the pin is defined as output in register 03<sub>n</sub>, the corresponding bit has no effect; this bit shows the real-time input pin status)

Bit #	Name	Bit Size	Description
7	In 7	1	0: GPIO input is LOW 1: GPIO input is HIGH
6	In 6	1	
5	In 5	1	
4	In 4	1	
3	In 3	1	
2	In 2	1	
1	In 1	1	
0	In 0	1	

## FXL6408

**Table 18. INTERRUPT MASK** (Address 11<sub>h</sub>; if the pin is defined as output in register 03<sub>h</sub>, the corresponding bit has no effect; this bit enables the interrupt generation from input pin state change to INT)

Bit #	Name	Bit Size	Description
7	In 7	1	0: GPIO input interrupt is generated 1: GPIO input interrupt is masked
6	In 6	1	
5	In 5	1	
4	In 4	1	
3	In 3	1	
2	In 2	1	
1	In 1	1	
0	In 0	1	

**Table 19. INTERRUPT STATUS** (Address 13<sub>h</sub>; this bit is HIGH if input GPIO ≠ default state (register 09<sub>h</sub>); the flag is cleared after being read by the master (bit returns to 0); the input must go back to default state and change again before this flag is raised again)

Bit #	Name	Bit Size	Description
7	In 7	1	0: GPIO input is in default state or the flag has been cleared 1: GPIO input has changed state from default
6	In 6	1	
5	In 5	1	
4	In 4	1	
3	In 3	1	
2	In 2	1	
1	In 1	1	
0	In 0	1	

## ORDERING INFORMATION

**Table 20. ORDERING INFORMATION**

Part Number	Top Mark	Operating Temperature Range	Package	Packing Method <sup>†</sup>
FXL6408UMX	XT	-40 to 85°C	16-Lead Ultra-thin Molded Leadless Package, Quad, 1.8 x 2.6 mm , 0.4P	5000 / Tape & Reel

<sup>†</sup>For information on tape and reel specifications, including part orientation and tape sizes, please refer to our Tape and Reel Packaging Specifications Brochure, [BRD8011/D](#).



**UQFN16 1.8x2.6, 0.4P**  
CASE 523BF  
ISSUE O

DATE 31 OCT 2016

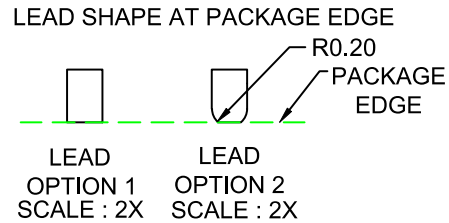
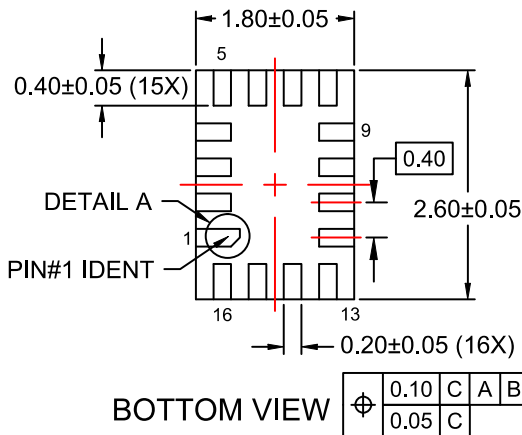
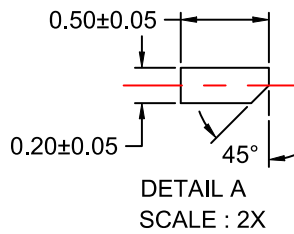
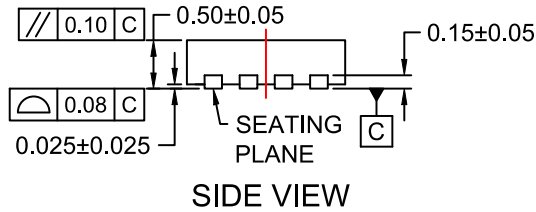
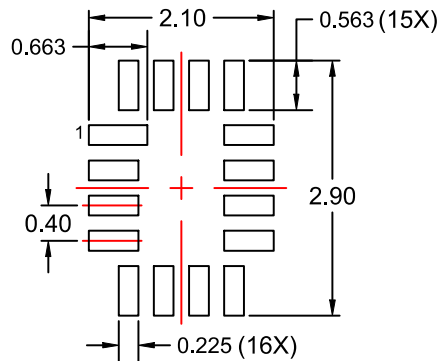
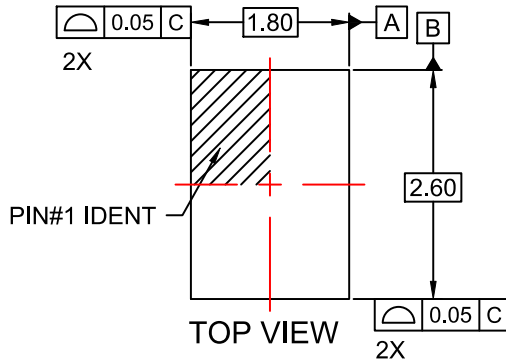

**NOTES:**

- A. PACKAGE DOES NOT FULLY CONFORM TO JEDEC STANDARD.
- B. DIMENSIONS ARE IN MILLIMETERS.
- C. DIMENSIONS AND TOLERANCES PER ASME Y14.5M, 2009.
- D. LAND PATTERN RECOMMENDATION IS EXISTING INDUSTRY LAND PATTERN.
- E. TERMINAL SHAPE MAY VARY ACCORDING TO PACKAGE SUPPLIER, SEE TERMINAL SHAPE VARIANTS.

<b>DOCUMENT NUMBER:</b>	<b>98AON13709G</b>	Electronic versions are uncontrolled except when accessed directly from the Document Repository. Printed versions are uncontrolled except when stamped "CONTROLLED COPY" in red.
<b>DESCRIPTION:</b>	<b>UQFN16 1.8x2.6, 0.4P</b>	<b>PAGE 1 OF 1</b>

ON Semiconductor and are trademarks of Semiconductor Components Industries, LLC dba ON Semiconductor or its subsidiaries in the United States and/or other countries. ON Semiconductor reserves the right to make changes without further notice to any products herein. ON Semiconductor makes no warranty, representation or guarantee regarding the suitability of its products for any particular purpose, nor does ON Semiconductor assume any liability arising out of the application or use of any product or circuit, and specifically disclaims any and all liability, including without limitation special, consequential or incidental damages. ON Semiconductor does not convey any license under its patent rights nor the rights of others.

**onsemi**, **Onsemi**, and other names, marks, and brands are registered and/or common law trademarks of Semiconductor Components Industries, LLC dba "**onsemi**" or its affiliates and/or subsidiaries in the United States and/or other countries. **onsemi** owns the rights to a number of patents, trademarks, copyrights, trade secrets, and other intellectual property. A listing of **onsemi**'s product/patent coverage may be accessed at [www.onsemi.com/site/pdf/Patent-Marking.pdf](http://www.onsemi.com/site/pdf/Patent-Marking.pdf). **onsemi** reserves the right to make changes at any time to any products or information herein, without notice. The information herein is provided "as-is" and **onsemi** makes no warranty, representation or guarantee regarding the accuracy of the information, product features, availability, functionality, or suitability of its products for any particular purpose, nor does **onsemi** assume any liability arising out of the application or use of any product or circuit, and specifically disclaims any and all liability, including without limitation special, consequential or incidental damages. Buyer is responsible for its products and applications using **onsemi** products, including compliance with all laws, regulations and safety requirements or standards, regardless of any support or applications information provided by **onsemi**. "Typical" parameters which may be provided in **onsemi** data sheets and/or specifications can and do vary in different applications and actual performance may vary over time. All operating parameters, including "Typicals" must be validated for each customer application by customer's technical experts. **onsemi** does not convey any license under any of its intellectual property rights nor the rights of others. **onsemi** products are not designed, intended, or authorized for use as a critical component in life support systems or any FDA Class 3 medical devices or medical devices with a same or similar classification in a foreign jurisdiction or any devices intended for implantation in the human body. Should Buyer purchase or use **onsemi** products for any such unintended or unauthorized application, Buyer shall indemnify and hold **onsemi** and its officers, employees, subsidiaries, affiliates, and distributors harmless against all claims, costs, damages, and expenses, and reasonable attorney fees arising out of, directly or indirectly, any claim of personal injury or death associated with such unintended or unauthorized use, even if such claim alleges that **onsemi** was negligent regarding the design or manufacture of the part. **onsemi** is an Equal Opportunity/Affirmative Action Employer. This literature is subject to all applicable copyright laws and is not for resale in any manner.

## ADDITIONAL INFORMATION

### TECHNICAL PUBLICATIONS:

Technical Library: [www.onsemi.com/design/resources/technical-documentation](http://www.onsemi.com/design/resources/technical-documentation)  
onsemi Website: [www.onsemi.com](http://www.onsemi.com)

### ONLINE SUPPORT: [www.onsemi.com/support](http://www.onsemi.com/support)

For additional information, please contact your local Sales Representative at [www.onsemi.com/support/sales](http://www.onsemi.com/support/sales)

