

## Check-choke valve, Series CC04

- $Q_n 2 \rightarrow 1 = 70-1850 \text{ l/min}$
- direction of throttle  $2 \rightarrow 1$
- exhaust air throttling
- push-in fitting / External thread

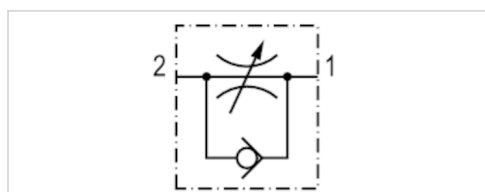

Working pressure min./max.	0,5 ... 10 bar
Ambient temperature min./max.	-10 ... 60 °C
Medium temperature min./max.	-10 ... 60 °C
Medium	Compressed air



### Technical data

Part No.	Port 1	Port 2	Throttle bore	Flow	Fig.
			Ø	$Q_n 2 \rightarrow 1$	
R412010564	Ø 4	M5	2 mm	70 l/min	Fig. 1
R412010565	Ø 6	M5	2 mm	110 l/min	Fig. 1
R412010568	Ø 4	G 1/8	3,5 mm	150 l/min	Fig. 2
R412010569	Ø 6	G 1/8	3,5 mm	390 l/min	Fig. 2
R412010570	Ø 8	G 1/8	3,5 mm	470 l/min	Fig. 2
R412010571	Ø 6	G 1/4	4,5 mm	390 l/min	Fig. 3
R412010572	Ø 8	G 1/4	4,5 mm	490 l/min	Fig. 3
R412010573	Ø 10	G 1/4	4,5 mm	520 l/min	Fig. 3
R412010574	Ø 8	G 3/8	6,6 mm	860 l/min	Fig. 4
R412010575	Ø 10	G 3/8	6,6 mm	900 l/min	Fig. 4
R412010576	Ø 12	G 3/8	6,6 mm	960 l/min	Fig. 4
R412010577	Ø 10	G 1/2	6,6 mm	1530 l/min	Fig. 5
R412010578	Ø 12	G 1/2	6,6 mm	1850 l/min	Fig. 5

Nominal flow  $Q_n$  at 6 bar and  $\Delta p = 1 \text{ bar}$

## Technical information

Material	
Housing	Polyamide
Seals	Acrylonitrile butadiene rubber
Port	Brass, nickel-plated

## Dimensions

### Dimensions

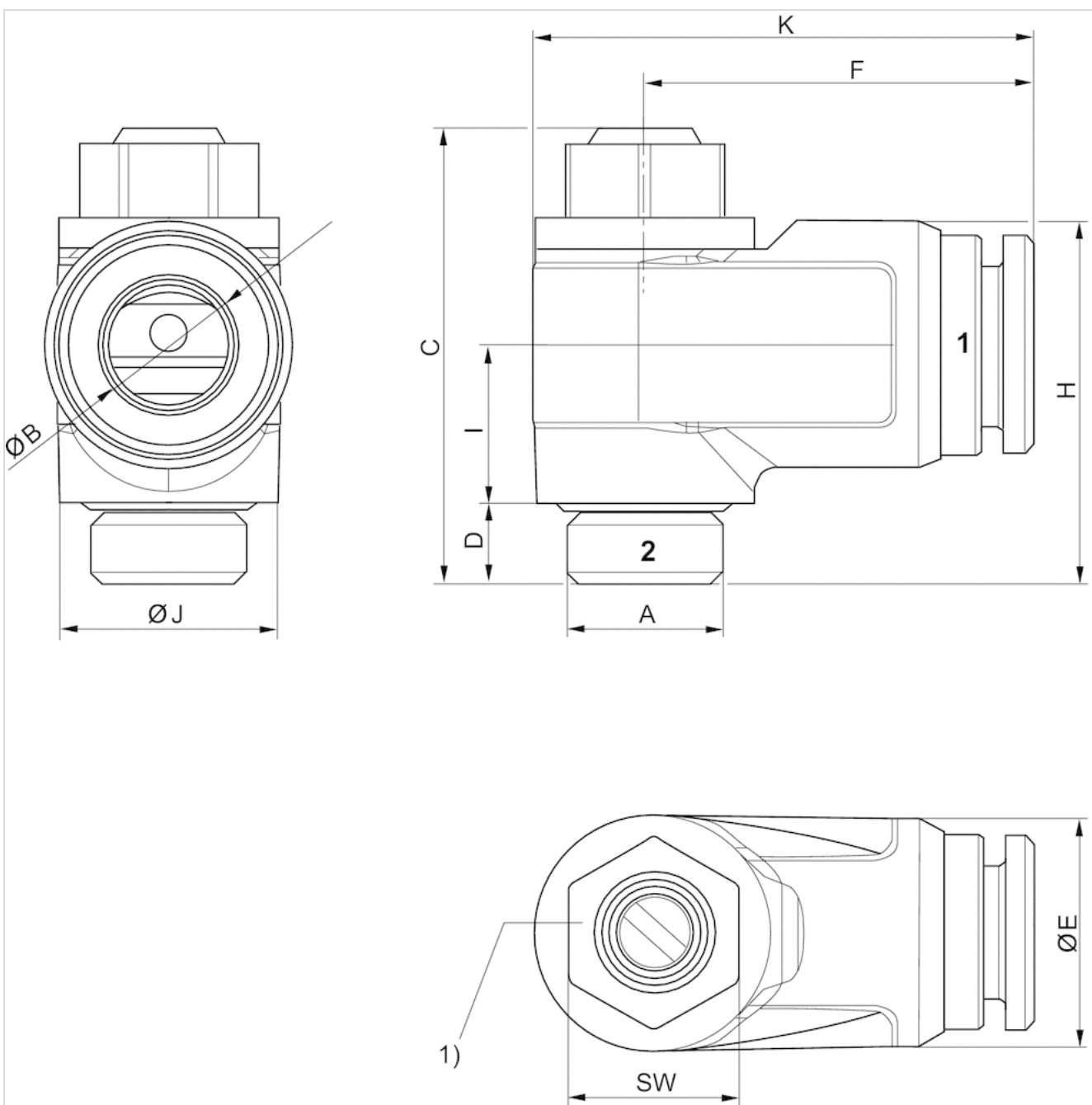

1) Recommended tightening torque M:M 5: 1.1 Nm -0.2G 1/8: 3.0 Nm -0.3G 1/4: 6.0 Nm -0.6G 3/8: 8.0 Nm -1.0G 1/2: 10.0 Nm -1.0

## Dimensions

Part No.	Port 1	Port 2	Ø B	C	D	Ø E	F	K	H	I	Ø J	SW
R412010564	Ø 4	M5	4	21.8	4	9	15.9	20.4	12	7.5	8.7	7
R412010565	Ø 6	M5	6	21.8	4	11.1	17.2	21.8	13	7.5	8.7	7
R412010568	Ø 4	G 1/8	4	28.5	5.5	11.5	21.9	28.8	21	9.8	13.6	10
R412010569	Ø 6	G 1/8	6	28.5	5.5	13.5	22.4	29.3	21.7	9.8	13.6	10
R412010570	Ø 8	G 1/8	8	28.5	5.5	15.5	24.2	31.1	22.7	9.8	13.6	10
R412010571	Ø 6	G 1/4	6	33.6	6.5	13	24.3	33.5	25.3	12.8	17.6	13
R412010572	Ø 8	G 1/4	8	33.6	6.5	15.5	26.6	35.5	25.3	11.5	17.6	13
R412010573	Ø 10	G 1/4	10	33.6	6.5	18.1	29.2	38.1	26.7	11.5	17.6	13
R412010574	Ø 8	G 3/8	8	40.8	7	15.6	28.2	40.6	23.6	15.8	22.2	16
R412010575	Ø 10	G 3/8	10	40.8	7	19	32	43.3	33.5	16.4	22.2	16
R412010576	Ø 12	G 3/8	12	40.8	7	22.1	34.2	45.4	35.6	17.8	22.2	16
R412010577	Ø 10	G 1/2	10	47.8	8.3	19.2	34	47.7	41.1	20.3	26.6	18
R412010578	Ø 12	G 1/2	12	47.8	8.3	22	36.1	49.8	43.9	21.5	26.6	18

## Diagrams

Flow diagram Fig. 1

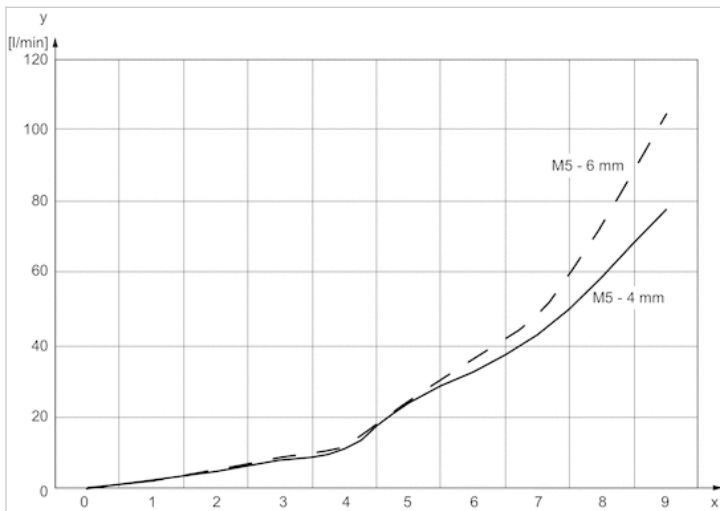

x = rotations of the throttle screw y = flow rate Qn

Flow diagram Fig. 2

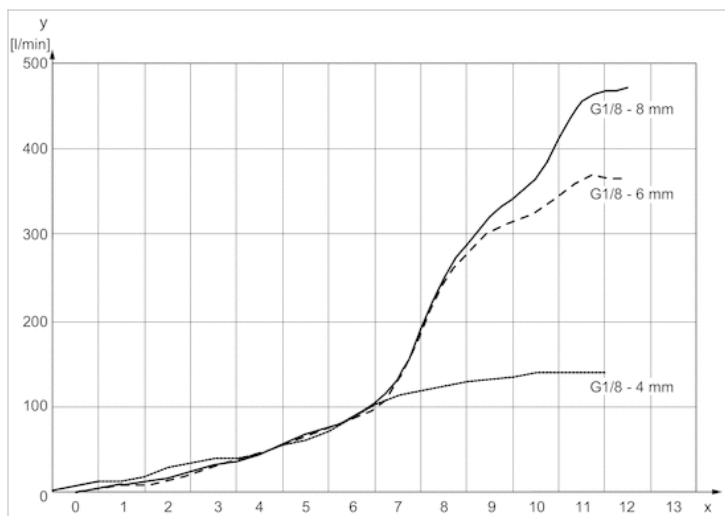

x = rotations of the throttle screw y = flow rate Qn

Flow diagram Fig. 3

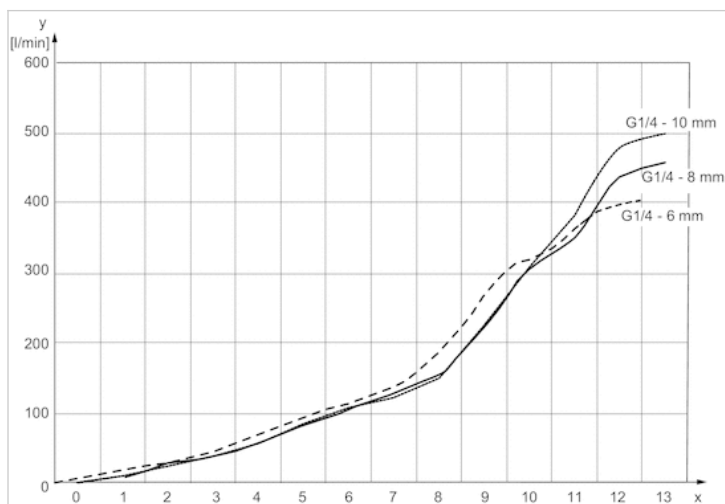

x = rotations of the throttle screw y = flow rate Qn

Flow diagram Fig. 4

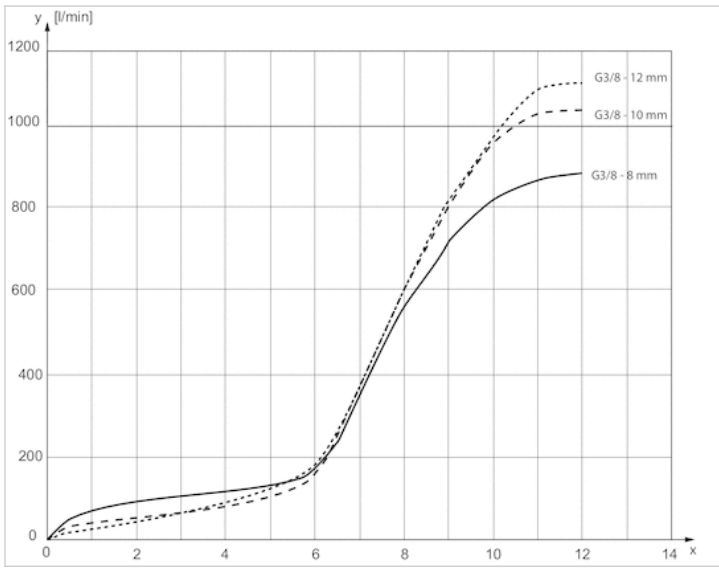

x = rotations of the throttle screw y = flow rate Qn

Flow diagram Fig. 5

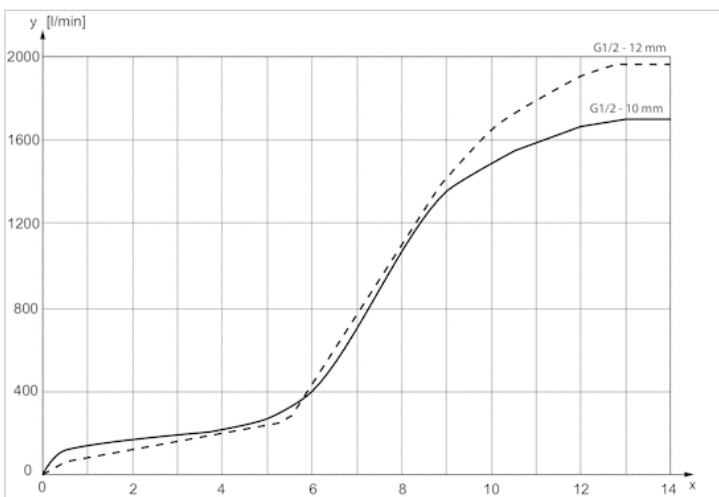

x = rotations of the throttle screw y = flow rate Qn