

FEATURES

PLL generated or direct master clock
Low EMI design
108 dB DAC/107 dB ADC dynamic range and SNR
-94 dB THD + N
3.3 V single supply
Tolerance for 5 V logic inputs
Supports 24 bits and 8 kHz to 192 kHz sample rates
Differential ADC input
Single-ended DAC output
Log volume control with autoramp function
SPI controllable for flexibility
Software-controllable clickless mute
Software power-down
Right-justified, left-justified, I²S-justified, and TDM modes
Master and slave modes up to 16-channel input/output
48-lead LQFP package
Qualified for automotive applications

APPLICATIONS

Automotive audio systems
Home Theater Systems
Set-top boxes
Digital audio effects processors

GENERAL DESCRIPTION

The AD1938 is a high performance, single-chip codec that provides four analog-to-digital converters (ADCs) with input and eight digital-to-analog converters (DACs) with single-ended output using the Analog Devices, Inc., patented multibit sigma-delta (Σ - Δ) architecture. An SPI port is included, allowing a microcontroller to adjust volume and many other parameters.

The AD1938 operates from 3.3 V digital and analog supplies. The AD1938 is available in a 48-lead (single-ended output) LQFP package. Other members of this family include a differential DAC output and I²C[®] control port version.

The AD1938 is designed for low EMI. This consideration is apparent in both the system and circuit design architectures. By using the on-board PLL to derive the master clock from the LR clock or from an external crystal, the AD1938 eliminates the need for a separate high frequency master clock and can also be used with a suppressed bit clock. The DACs and ADCs are designed using the latest Analog Devices continuous time architectures to further minimize EMI. By using 3.3 V supplies, power consumption is minimized, further reducing emissions.

FUNCTIONAL BLOCK DIAGRAM

Figure 1.

Rev. E

[Document Feedback](#)

Information furnished by Analog Devices is believed to be accurate and reliable. However, no responsibility is assumed by Analog Devices for its use, nor for any infringements of patents or other rights of third parties that may result from its use. Specifications subject to change without notice. No license is granted by implication or otherwise under any patent or patent rights of Analog Devices. Trademarks and registered trademarks are the property of their respective owners.

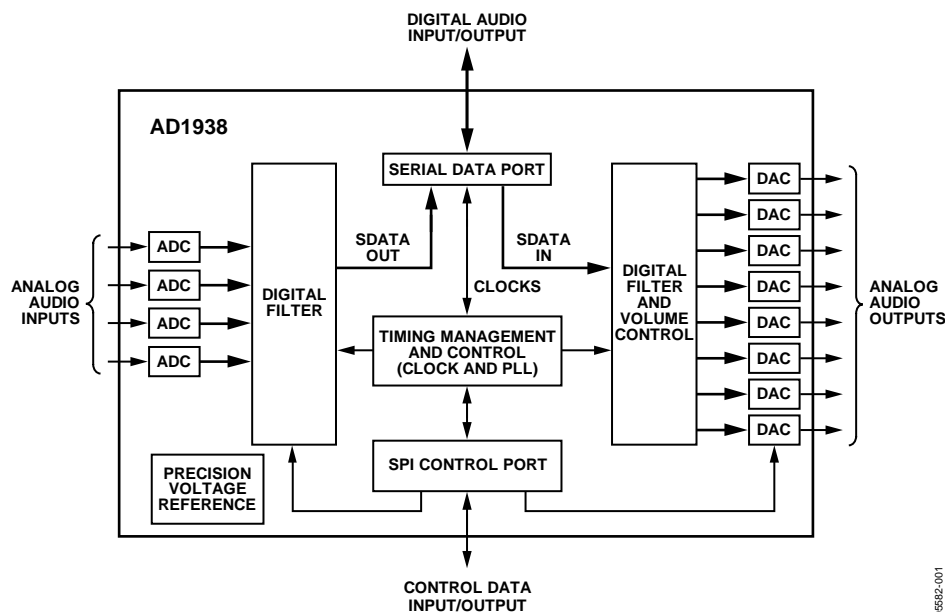
One Technology Way, P.O. Box 9106, Norwood, MA 02062-9106, U.S.A.
 Tel: 781.329.4700 ©2006–2013 Analog Devices, Inc. All rights reserved.
[Technical Support](#) www.analog.com

05982-001

TABLE OF CONTENTS

| | | | |
|--|----|--|----|
| Features | 1 | Analog-to-Digital Converters (ADCs)..... | 13 |
| Applications..... | 1 | Digital-to-Analog Converters (DACs)..... | 13 |
| General Description | 1 | Clock Signals..... | 13 |
| Functional Block Diagram | 1 | Reset and Power-Down | 14 |
| Revision History | 2 | Serial Control Port | 14 |
| Specifications..... | 3 | Power Supply and Voltage Reference..... | 15 |
| Test Conditions..... | 3 | Serial Data Ports—Data Format..... | 15 |
| Analog Performance Specifications | 3 | Time-Division Multiplexed (TDM) Modes..... | 15 |
| Crystal Oscillator Specifications..... | 4 | Daisy-Chain Mode | 19 |
| Digital Input/Output Specifications..... | 5 | Control Registers..... | 24 |
| Power Supply Specifications..... | 5 | Definitions..... | 24 |
| Digital Filters..... | 6 | PLL and Clock Control Registers..... | 24 |
| Timing Specifications | 7 | DAC Control Registers..... | 25 |
| Absolute Maximum Ratings..... | 8 | ADC Control Registers..... | 27 |
| Thermal Resistance | 8 | Additional Modes..... | 29 |
| ESD Caution..... | 8 | Applications Circuits..... | 30 |
| Pin Configuration and Function Descriptions..... | 9 | Outline Dimensions | 31 |
| Typical Performance Characteristics | 11 | Ordering Guide | 31 |
| Theory of Operation | 13 | | |

REVISION HISTORY

2/13—Rev. D to Rev. E

| | |
|--|---|
| Change to t_{CLH} Parameter, Table 7 | 7 |
|--|---|

7/11—Rev. C to Rev. D

| | |
|---|---|
| Changes to Table 10, DSDATAx/ASDATAx Pin Descriptions... .. | 9 |
|---|---|

1/11—Rev. B to Rev. C

| | |
|--|------------|
| Added Automotive Information | Throughout |
| Change to Table 2, Introductory Text | 4 |
| Change to Table 4, Introductory Text | 5 |
| Change to Table 7, Introductory Text | 7 |
| Changes to Ordering Guide | 31 |

8/09—Rev. A to Rev. B

| | |
|---|----|
| Changes to Table 16 Title..... | 24 |
| Changes to Figure 18 and Table 19 Titles..... | 25 |
| Changes to Table 20 Title..... | 26 |
| Changes to Table 23 and Table 24 Titles..... | 27 |
| Changes to Table 25 Title..... | 28 |
| Changes to Ordering Guide | 31 |

7/08—Rev. 0 to Rev. A

| | |
|--|----|
| Changes to Table 7..... | 7 |
| Changes to Figure 2..... | 9 |
| Changes to Table 10 | 9 |
| Changes to Clock Signals Section | 13 |
| Changes to Reset and Power-Down Section..... | 14 |
| Change to Serial Control Port Section | 14 |
| Changes to Table 11 | 14 |
| Changes to Figure 24 and Figure 25 | 22 |
| Changes to Figure 26..... | 23 |
| Changes to Definitions Section | 24 |
| Changes to Table 16 | 24 |
| Change to Additional Modes Section..... | 29 |
| Change to Figure 30 | 30 |

5/06—Revision 0: Initial Version

SPECIFICATIONS

TEST CONDITIONS

Performance of all channels is identical, exclusive of the interchannel gain mismatch and interchannel phase deviation specifications.

| | |
|-----------------------------------|--|
| Supply voltages (AVDD, DVDD) | 3.3 V |
| Temperature range ¹ | as specified in Table 1 and Table 2 |
| Master clock | 12.288 MHz (48 kHz f_s , 256 × f_s mode) |
| Input sample rate | 48 kHz |
| Measurement bandwidth | 20 Hz to 20 kHz |
| Word width | 24 bits |
| Load capacitance (digital output) | 20 pF |
| Load current (digital output) | ±1 mA or 1.5 kΩ to ½ DVDD supply |
| Input voltage high | 2.0 V |
| Input voltage low | 0.8 V |

¹ Functionally guaranteed at –40°C to +125°C case temperature.

ANALOG PERFORMANCE SPECIFICATIONS

Specifications guaranteed at an ambient temperature of 25°C.

Table 1.

| Parameter | Conditions | Min | Typ | Max | Unit |
|---|-------------------------------|-------|-------------|-------|---------------|
| ANALOG-TO-DIGITAL CONVERTERS | | | | | |
| ADC Resolution | All ADCs | | 24 | | Bits |
| Dynamic Range | 20 Hz to 20 kHz, –60 dB input | | | | |
| No Filter (RMS) | | 98 | 102 | | dB |
| With A-Weighted Filter (RMS) | | 100 | 105 | | dB |
| Total Harmonic Distortion + Noise | –1 dBFS | | –96 | –87 | dB |
| Full-Scale Input Voltage (Differential) | | | 1.9 | | V rms |
| Gain Error | | –10 | | +10 | % |
| Interchannel Gain Mismatch | | –0.25 | | +0.25 | dB |
| Offset Error | | –10 | 0 | +10 | mV |
| Gain Drift | | | 100 | | ppm/°C |
| Interchannel Isolation | | | –110 | | dB |
| CMRR | 100 mV rms, 1 kHz | | 55 | | dB |
| | 100 mV rms, 20 kHz | | 55 | | dB |
| Input Resistance | | | 14 | | kΩ |
| Input Capacitance | | | 10 | | pF |
| Input Common-Mode Bias Voltage | | | 1.5 | | V |
| DIGITAL-TO-ANALOG CONVERTERS | | | | | |
| Dynamic Range | 20 Hz to 20 kHz, –60 dB input | | | | |
| No Filter (RMS) | | 98 | 104 | | dB |
| With A-Weighted Filter (RMS) | | 100 | 106 | | dB |
| With A-Weighted Filter (Average) | | | 108 | | dB |
| Total Harmonic Distortion + Noise | 0 dBFS | | | | |
| Single-Ended Version | Two channels running | | –92 | | dB |
| Single-Ended Version | Eight channels running | | –86 | –75 | dB |
| Full-Scale Output Voltage | | | 0.88 (2.48) | | V rms (V p-p) |
| Gain Error | | –10 | | +10 | % |
| Interchannel Gain Mismatch | | –0.2 | | +0.2 | dB |
| Offset Error | | –25 | –4 | +25 | mV |
| Gain Drift | | –30 | | +30 | ppm/°C |

| Parameter | Conditions | Min | Typ | Max | Unit |
|-------------------------------|------------|------|-------|------|---------|
| Interchannel Isolation | | | 100 | | dB |
| Interchannel Phase Deviation | | | 0 | | Degrees |
| Volume Control Step | | | 0.375 | | dB |
| Volume Control Range | | | 95 | | dB |
| De-emphasis Gain Error | | | | ±0.6 | dB |
| Output Resistance at Each Pin | | | 100 | | Ω |
| REFERENCE | | | | | |
| Internal Reference Voltage | FILTR pin | | 1.50 | | V |
| External Reference Voltage | FILTR pin | 1.32 | 1.50 | 1.68 | V |
| Common-Mode Reference Output | CM pin | | 1.50 | | V |

Specifications measured at a case temperature of 125°C.

Table 2.

| Parameter | Conditions | Min | Typ | Max | Unit |
|---|-------------------------------|-------|----------------|-------|---------------|
| ANALOG-TO-DIGITAL CONVERTERS | | | | | |
| ADC Resolution | All ADCs | | 24 | | Bits |
| Dynamic Range | 20 Hz to 20 kHz, –60 dB input | | | | |
| No Filter (RMS) | | 95 | 102 | | dB |
| With A-Weighted Filter (RMS) | | 97 | 105 | | dB |
| Total Harmonic Distortion + Noise | –1 dBFS | | –96 | –87 | dB |
| Full-Scale Input Voltage (Differential) | | | 1.9 | | V rms |
| Gain Error | | –10 | | +10 | % |
| Interchannel Gain Mismatch | | –0.25 | | +0.25 | dB |
| Offset Error | | –10 | 0 | +10 | mV |
| DIGITAL-TO-ANALOG CONVERTERS | | | | | |
| Dynamic Range | 20 Hz to 20 kHz, –60 dB input | | | | |
| No Filter (RMS) | | 98 | 104 | | dB |
| With A-Weighted Filter (RMS) | | 100 | 106 | | dB |
| With A-Weighted Filter (Average) | | | 108 | | dB |
| Total Harmonic Distortion + Noise | 0 dBFS | | | | |
| Single-Ended Version | Two channels running | | –92 | | dB |
| Single-Ended Version | Eight channels running | | –86 | –70 | dB |
| Full-Scale Output Voltage | | | 0.8775 (2.482) | | V rms (V p-p) |
| Gain Error | | –10 | | +10 | % |
| Interchannel Gain Mismatch | | –0.2 | | +0.2 | dB |
| Offset Error | | –25 | –4 | 25 | mV |
| Gain Drift | | –30 | | 30 | ppm/°C |
| REFERENCE | | | | | |
| Internal Reference Voltage | FILTR pin | | 1.50 | | V |
| External Reference Voltage | FILTR pin | 1.32 | 1.50 | 1.68 | V |
| Common-Mode Reference Output | CM pin | | 1.50 | | V |

CRYSTAL OSCILLATOR SPECIFICATIONS

Table 3.

| Parameter | Min | Typ | Max | Unit |
|------------------|-----|-----|-----|-------|
| Transconductance | | 3.5 | | mmhos |

DIGITAL INPUT/OUTPUT SPECIFICATIONS

$-40^{\circ}\text{C} < T_c < +125^{\circ}\text{C}$, DVDD = 3.3 V \pm 10%.

Table 4.

| Parameter | Conditions/Comments | Min | Typ | Max | Unit |
|--|--|-------------|-----|-----|---------------|
| High Level Input Voltage (V_{IH}) | | 2.0 | | | V |
| High Level Input Voltage (V_{IH}) | MCLKI/XI pin | 2.2 | | | V |
| Low Level Input Voltage (V_{IL}) | | | | 0.8 | V |
| Input Leakage | I_{IH} @ $V_{IH} = 2.4$ V I_{IL} @ $V_{IL} = 0.8$ V | | | 10 | μA |
| High Level Output Voltage (V_{OH}) | $I_{OH} = 1$ mA | DVDD – 0.60 | | | V |
| Low Level Output Voltage (V_{OL}) | $I_{OL} = 1$ mA | | | 0.4 | V |
| Input Capacitance | | | | 5 | pF |

POWER SUPPLY SPECIFICATIONS

Table 5.

| Parameter | Conditions/Comments | Min | Typ | Max | Unit |
|-------------------------------------|-----------------------------------|-----|-----|-----|------|
| SUPPLIES | | | | | |
| Voltage | DVDD | 3.0 | 3.3 | 3.6 | V |
| | AVDD | 3.0 | 3.3 | 3.6 | V |
| Digital Current | Master clock = 256 f_s | | | | |
| Normal Operation | $f_s = 48$ kHz | | 56 | | mA |
| | $f_s = 96$ kHz | | 65 | | mA |
| | $f_s = 192$ kHz | | 95 | | mA |
| Power-Down | $f_s = 48$ kHz to 192 kHz | | 2.0 | | mA |
| Analog Current | | | | | |
| Normal Operation | | | 74 | | mA |
| Power-Down | | | 23 | | mA |
| DISSIPATION | | | | | |
| Operation | Master clock = 256 f_s , 48 kHz | | | | |
| All Supplies | | | 429 | | mW |
| Digital Supply | | | 185 | | mW |
| Analog Supply | | | 244 | | mW |
| Power-Down, All Supplies | | | 83 | | mW |
| POWER SUPPLY REJECTION RATIO | | | | | |
| Signal at Analog Supply Pins | 1 kHz, 200 mV p-p | | 50 | | dB |
| | 20 kHz, 200 mV p-p | | 50 | | dB |

DIGITAL FILTERS

Table 6.

| Parameter | Mode | Factor | Min | Typ | Max | Unit |
|--------------------------|---------------------------------|---------------|-----|-------------|------------|---------|
| ADC DECIMATION FILTER | All modes, typical @ 48 kHz | | | | | |
| Pass Band | | $0.4375 f_s$ | | 21 | | kHz |
| Pass-Band Ripple | | | | ± 0.015 | | dB |
| Transition Band | | $0.5 f_s$ | | 24 | | kHz |
| Stop Band | | $0.5625 f_s$ | | 27 | | kHz |
| Stop-Band Attenuation | | | 79 | | | dB |
| Group Delay | | $22.9844/f_s$ | | 479 | | μs |
| DAC INTERPOLATION FILTER | | | | | | |
| Pass Band | 48 kHz mode, typical @ 48 kHz | $0.4535 f_s$ | | 22 | | kHz |
| | 96 kHz mode, typical @ 96 kHz | $0.3646 f_s$ | 35 | | | kHz |
| | 192 kHz mode, typical @ 192 kHz | $0.3646 f_s$ | | 70 | | kHz |
| Pass-Band Ripple | 48 kHz mode, typical @ 48 kHz | | | | ± 0.01 | dB |
| | 96 kHz mode, typical @ 96 kHz | | | | ± 0.05 | dB |
| | 192 kHz mode, typical @ 192 kHz | | | | ± 0.1 | dB |
| Transition Band | 48 kHz mode, typical @ 48 kHz | $0.5 f_s$ | | 24 | | kHz |
| | 96 kHz mode, typical @ 96 kHz | $0.5 f_s$ | | 48 | | kHz |
| | 192 kHz mode, typical @ 192 kHz | $0.5 f_s$ | | 96 | | kHz |
| Stop Band | 48 kHz mode, typical @ 48 kHz | $0.5465 f_s$ | | 26 | | kHz |
| | 96 kHz mode, typical @ 96 kHz | $0.6354 f_s$ | | 61 | | kHz |
| | 192 kHz mode, typical @ 192 kHz | $0.6354 f_s$ | | 122 | | kHz |
| Stop-Band Attenuation | 48 kHz mode, typical @ 48 kHz | | 70 | | | dB |
| | 96 kHz mode, typical @ 96 kHz | | 70 | | | dB |
| | 192 kHz mode, typical @ 192 kHz | | 70 | | | dB |
| Group Delay | 48 kHz mode, typical @ 48 kHz | $25/f_s$ | | 521 | | μs |
| | 96 kHz mode, typical @ 96 kHz | $11/f_s$ | | 115 | | μs |
| | 192 kHz mode, typical @ 192 kHz | $8/f_s$ | | 42 | | μs |

TIMING SPECIFICATIONS

-40°C < T_c < +125°C, DVDD = 3.3 V ± 10%.

Table 7.

| Parameter | Condition | Comments | Min | Max | Unit |
|---|----------------------------------|--|------|------|-------------------|
| INPUT MASTER CLOCK (MCLK) AND RESET | | | | | |
| t _{MH} | MCLK duty cycle | DAC/ADC clock source = PLL clock @ 256 f _s , 384 f _s , 512 f _s , and 768 f _s | 40 | 60 | % |
| t _{MH} | | DAC/ADC clock source = direct MCLK @ 512 f _s (bypass on-chip PLL) | 40 | 60 | % |
| f _{MCLK} | MCLK frequency | PLL mode, 256 f _s reference | 6.9 | 13.8 | MHz |
| f _{MCLK} | | Direct 512 f _s mode | | 27.6 | MHz |
| t _{PDR} | $\overline{\text{RST}}$ low | | 15 | | ns |
| t _{PDRR} | $\overline{\text{RST}}$ recovery | Reset to active output | 4096 | | t _{MCLK} |
| PLL | | | | | |
| Lock time | MCLK and LR clock input | | | 10 | ms |
| 256 f _s VCO Clock, Output Duty Cycle, MCLKO/XO Pin | | | 40 | 60 | % |
| SPI PORT | | | | | |
| t _{CCH} | CCLK high | See Figure 11 | 35 | | ns |
| t _{CCL} | CCLK low | | 35 | | ns |
| f _{CCLK} | CCLK frequency | f _{CCLK} = 1/t _{CCP} , only t _{CCP} shown in Figure 11 | | 10 | MHz |
| t _{CDS} | CIN setup | To CCLK rising | 10 | | ns |
| t _{CDH} | CIN hold | From CCLK rising | 10 | | ns |
| t _{CLS} | $\overline{\text{CLATCH}}$ setup | To CCLK rising | 10 | | ns |
| t _{CLH} | $\overline{\text{CLATCH}}$ hold | From CCLK rising | 10 | | ns |
| t _{CLH} | $\overline{\text{CLATCH}}$ high | Not shown in Figure 11 | 10 | | ns |
| t _{COE} | COUT enable | From CCLK falling | | 30 | ns |
| t _{COD} | COUT delay | From CCLK falling | | 30 | ns |
| t _{COH} | COUT hold | From CCLK falling, not shown in Figure 11 | 30 | | ns |
| t _{COTS} | COUT tristate | From CCLK falling | | 30 | ns |
| DAC SERIAL PORT | | | | | |
| t _{DBH} | DBCLK high | See Figure 24 | 10 | | ns |
| t _{DBL} | DBCLK low | Slave mode | 10 | | ns |
| t _{DLS} | DLRCLK setup | To DBCLK rising, slave mode | 10 | | ns |
| t _{DLH} | DLRCLK hold | From DBCLK rising, slave mode | 5 | | ns |
| t _{DLS} | DLRCLK skew | From DBCLK falling, master mode | -8 | +8 | ns |
| t _{DDS} | DSDATA setup | To DBCLK rising | 10 | | ns |
| t _{DDH} | DSDATA hold | From DBCLK rising | 5 | | ns |
| ADC SERIAL PORT | | | | | |
| t _{ABH} | ABCLK high | See Figure 25 | 10 | | ns |
| t _{ABL} | ABCLK low | Slave mode | 10 | | ns |
| t _{ALS} | ALRCLK setup | To ABCLK rising, slave mode | 10 | | ns |
| t _{ALH} | ALRCLK hold | From ABCLK rising, slave mode | 5 | | ns |
| t _{ALS} | ALRCLK skew | From ABCLK falling, master mode | -8 | +8 | ns |
| t _{ABDD} | ASDATA delay | From ABCLK falling | | 18 | ns |
| AUXILIARY INTERFACE | | | | | |
| t _{AXDS} | AAUXDATA setup | To AUXBCLK rising | 10 | | ns |
| t _{AXDH} | AAUXDATA hold | From AUXBCLK rising | 5 | | ns |
| t _{DXDD} | DAUXDATA delay | From AUXBCLK falling | | 18 | ns |
| t _{XBH} | AUXBCLK high | | 10 | | ns |
| t _{XBL} | AUXBCLK low | | 10 | | ns |
| t _{DLS} | AUXLRCLK setup | To AUXBCLK rising | 10 | | ns |
| t _{DLH} | AUXLRCLK hold | From AUXBCLK rising | 5 | | ns |

ABSOLUTE MAXIMUM RATINGS

Table 8.

| Parameter | Rating |
|-------------------------------------|------------------------|
| Analog (AVDD) | -0.3 V to +3.6 V |
| Digital (DVDD) | -0.3 V to +3.6 V |
| Input Current (Except Supply Pins) | ±20 mA |
| Analog Input Voltage (Signal Pins) | -0.3 V to AVDD + 0.3 V |
| Digital Input Voltage (Signal Pins) | -0.3 V to DVDD + 0.3 V |
| Operating Temperature Range (Case) | -40°C to +125°C |
| Storage Temperature Range | -65°C to +150°C |

Stresses above those listed under Absolute Maximum Ratings may cause permanent damage to the device. This is a stress rating only; functional operation of the device at these or any other conditions above those indicated in the operational section of this specification is not implied. Exposure to absolute maximum rating conditions for extended periods may affect device reliability.

THERMAL RESISTANCE

θ_{JA} represents thermal resistance, junction-to-ambient; θ_{JC} represents the thermal resistance, junction-to-case. All characteristics are for a 4-layer board.

Table 9. Thermal Resistance

| Package Type | θ_{JA} | θ_{JC} | Unit |
|--------------|---------------|---------------|------|
| 48-Lead LQFP | 50.1 | 17 | °C/W |

ESD CAUTION



ESD (electrostatic discharge) sensitive device. Charged devices and circuit boards can discharge without detection. Although this product features patented or proprietary protection circuitry, damage may occur on devices subjected to high energy ESD. Therefore, proper ESD precautions should be taken to avoid performance degradation or loss of functionality.

PIN CONFIGURATION AND FUNCTION DESCRIPTIONS

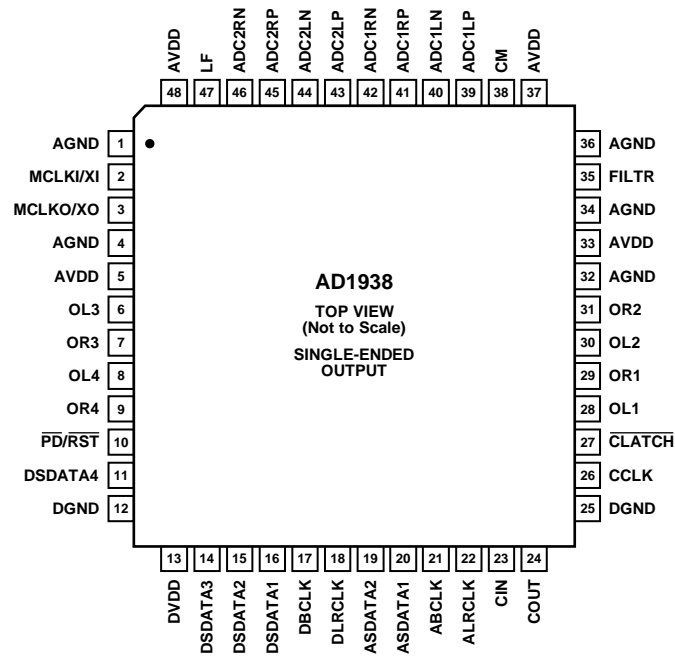

Figure 2. Pin Configuration, 48-Lead LQFP

Table 10. Pin Function Descriptions

| Pin No. | In/Out | Mnemonic | Description |
|---------|--------|----------------------------|---|
| 1 | I | AGND | Analog Ground. |
| 2 | I | MCLKI/XI | Master Clock Input/Crystal Oscillator Input. |
| 3 | O | MCLKO/XO | Master Clock Output/Crystal Oscillator Output. |
| 4 | I | AGND | Analog Ground. |
| 5 | I | AVDD | Analog Power Supply. Connect to analog 3.3 V supply. |
| 6 | O | OL3 | DAC 3 Left Output. |
| 7 | O | OR3 | DAC 3 Right Output. |
| 8 | O | OL4 | DAC 4 Left Output. |
| 9 | O | OR4 | DAC 4 Right Output. |
| 10 | I | $\overline{\text{PD/RST}}$ | Power-Down Reset (Active Low). |
| 11 | I/O | DSDATA4 | DAC Serial Input 4. Data input to DAC4 data in/TDM DAC2 data out (dual-line mode)/AUX DAC2 data out (to external DAC2). |
| 12 | I | DGND | Digital Ground. |
| 13 | I | DVDD | Digital Power Supply. Connect to digital 3.3 V supply. |
| 14 | I/O | DSDATA3 | DAC Serial Input 3. Data input to DAC3 data in/TDM DAC2 data in (dual-line mode)/AUX ADC2 data in (from external ADC2). |
| 15 | I/O | DSDATA2 | DAC Serial Input 2. Data input to DAC2 data in/TDM DAC data out/AUX ADC1 data in (from external ADC1). |
| 16 | I | DSDATA1 | DAC Serial Data Input 1. Data input to DAC1 data in/TDM DAC data in/TDM data in. |
| 17 | I/O | DBCLK | Bit Clock for DACs. |
| 18 | I/O | DLRCLK | LR Clock for DACs. |
| 19 | I/O | ASDATA2 | ADC Serial Data Output 2. Data output from ADC2/TDM ADC data in/AUX DAC1 data out (to external DAC1). |
| 20 | O | ASDATA1 | ADC Serial Data Output 1. Data output from ADC1/TDM ADC data out/TDM data out. |
| 21 | I/O | ABCLK | Bit Clock for ADCs. |
| 22 | I/O | ALRCLK | LR Clock for ADCs. |
| 23 | I | CIN | Control Data Input (SPI). |
| 24 | I/O | COUT | Control Data Output (SPI). |
| 25 | I | DGND | Digital Ground. |

| Pin No. | In/Out | Mnemonic | Description |
|---------|--------|----------|--|
| 26 | I | CCLK | Control Clock Input (SPI). |
| 27 | I | CLATCH | Latch Input for Control Data (SPI). |
| 28 | O | OL1 | DAC 1 Left Output. |
| 29 | O | OR1 | DAC 1 Right Output. |
| 30 | O | OL2 | DAC 2 Left Output. |
| 31 | O | OR2 | DAC 2 Right Output. |
| 32 | I | AGND | Analog Ground. |
| 33 | I | AVDD | Analog Power Supply. Connect to analog 3.3 V supply. |
| 34 | I | AGND | Analog Ground. |
| 35 | O | FILTR | Voltage Reference Filter Capacitor Connection. Bypass with 10 μ F 100 nF to AGND. |
| 36 | I | AGND | Analog Ground. |
| 37 | I | AVDD | Analog Power Supply. Connect to analog 3.3 V supply. |
| 38 | O | CM | Common-Mode Reference Filter Capacitor Connection. Bypass with 47 μ F 100 nF to AGND. |
| 39 | I | ADC1LP | ADC1 Left Positive Input. |
| 40 | I | ADC1LN | ADC1 Left Negative Input. |
| 41 | I | ADC1RP | ADC1 Right Positive Input. |
| 42 | I | ADC1RN | ADC1 Right Negative Input. |
| 43 | I | ADC2LP | ADC2 Left Positive Input. |
| 44 | I | ADC2LN | ADC2 Left Negative Input. |
| 45 | I | ADC2RP | ADC2 Right Positive Input. |
| 46 | I | ADC2RN | ADC2 Right Negative Input. |
| 47 | O | LF | PLL Loop Filter, Return to AVDD. |
| 48 | I | AVDD | Analog Power Supply. Connect to analog 3.3 V supply. |

TYPICAL PERFORMANCE CHARACTERISTICS

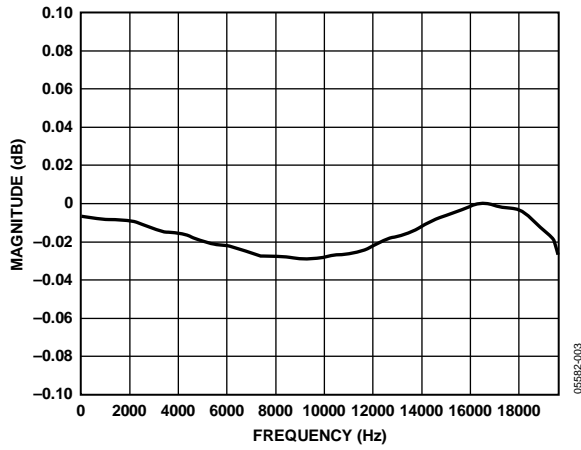

Figure 3. ADC Pass-Band Filter Response, 48 kHz

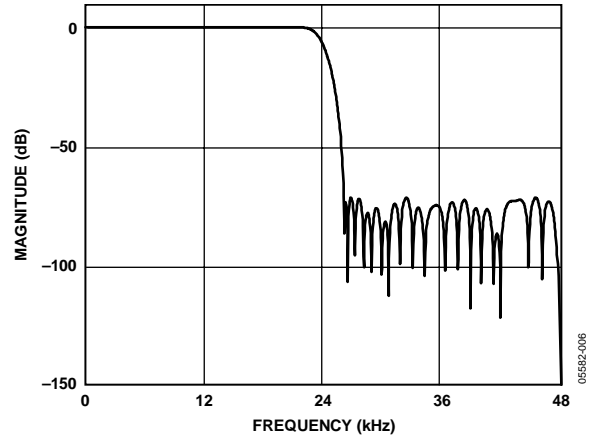

Figure 6. DAC Stop-Band Filter Response, 48 kHz

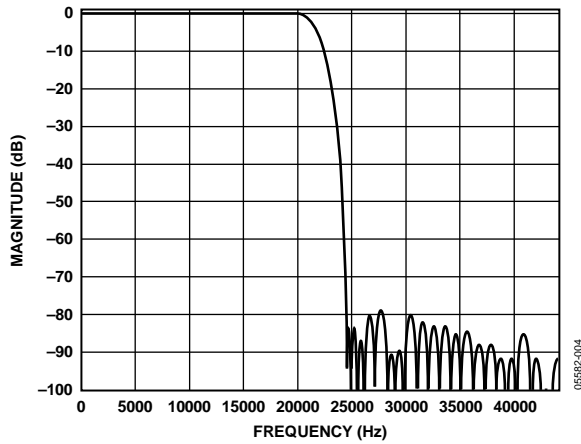

Figure 4. ADC Stop-Band Filter Response, 48 kHz

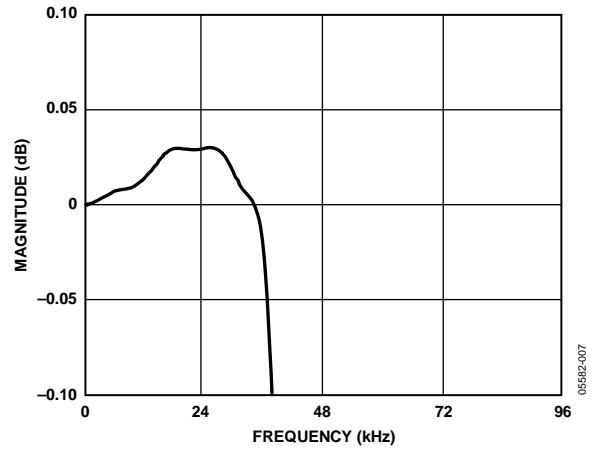

Figure 7. DAC Pass-Band Filter Response, 96 kHz

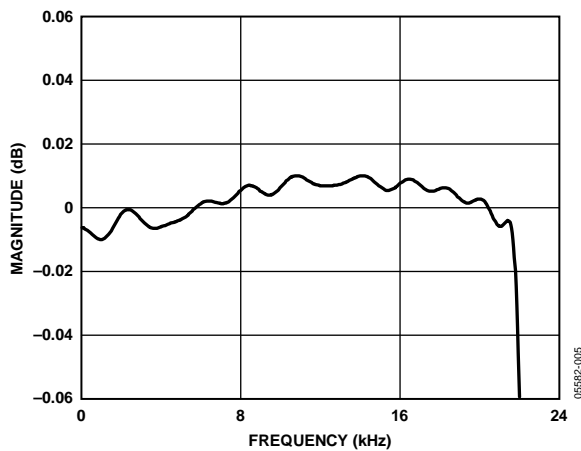

Figure 5. DAC Pass-Band Filter Response, 48 kHz

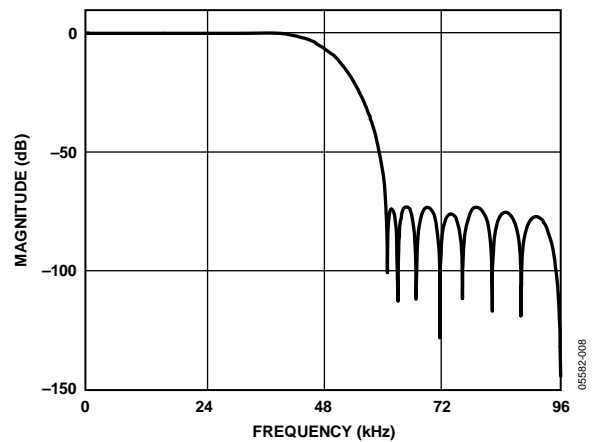

Figure 8. DAC Stop-Band Filter Response, 96 kHz

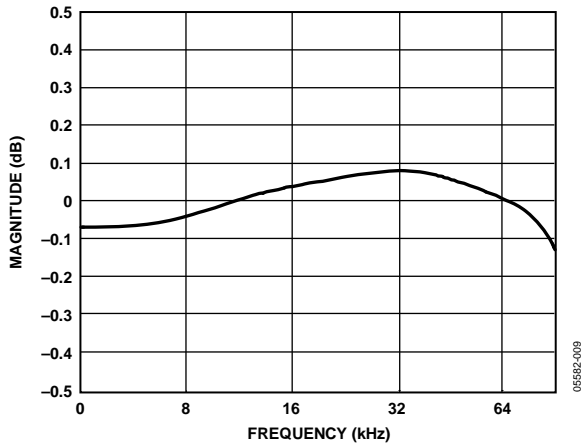

Figure 9. DAC Pass-Band Filter Response, 192 kHz

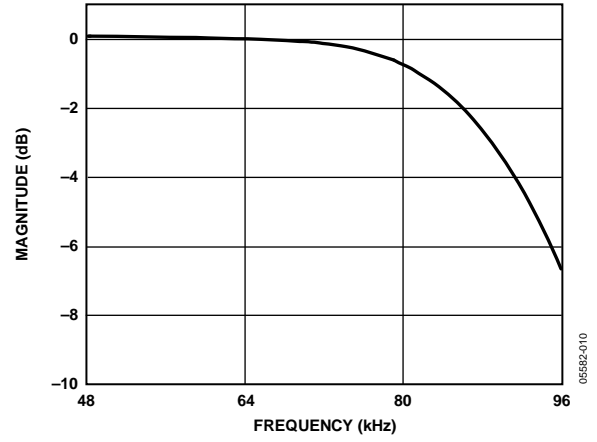

Figure 10. DAC Stop-Band Filter Response, 192 kHz

THEORY OF OPERATION

ANALOG-TO-DIGITAL CONVERTERS (ADCS)

There are four ADC channels in the [AD1938](#) configured as two stereo pairs with differential inputs. The ADCs can operate at a nominal sample rate of 48 kHz, 96 kHz, or 192 kHz. The ADCs include on-board digital antialiasing filters with 79 dB stop-band attenuation and linear phase response, operating at an oversampling ratio of 128 (48 kHz, 96 kHz, and 192 kHz modes). Digital outputs are supplied through two serial data output pins (one for each stereo pair) and a common frame clock (ALRCLK) and bit clock (ABCLK). Alternatively, one of the TDM modes can be used to access up to 16 channels on a single TDM data line.

The ADCs must be driven from a differential signal source for best performance. The input pins of the ADCs connect to internal switched capacitors. To isolate the external driving op amp from the glitches caused by the internal switched capacitors, each input pin should be isolated by using a series connected, external, 100 Ω resistor together with a 1 nF capacitor connected from each input to ground. This capacitor must be of high quality, for example, ceramic NPO or polypropylene film.

The differential inputs have a nominal common-mode voltage of 1.5 V. The voltage at the common-mode reference pin (CM) can be used to bias external op amps to buffer the input signals (see the Power Supply and Voltage Reference section). The inputs can also be ac-coupled and do not need an external dc bias to CM.

A digital high-pass filter can be switched in line with the ADCs under serial control to remove residual dc offsets. It has a 1.4 Hz, 6 dB per octave cutoff at a 48 kHz sample rate. The cutoff frequency scales directly with sample frequency.

DIGITAL-TO-ANALOG CONVERTERS (DACs)

The [AD1938](#) DAC channels are arranged as single-ended, four stereo pairs giving eight analog outputs for minimum external components. The DACs include on-board digital reconstruction filters with 70 dB stop-band attenuation and linear phase response, operating at an oversampling ratio of 4 (48 kHz or 96 kHz modes) or 2 (192 kHz mode). Each channel has its own independently programmable attenuator, adjustable in 255 steps in increments of 0.375 dB. Digital inputs are supplied through four serial data input pins (one for each stereo pair), a common frame clock (DLRCLK), and a bit clock (DBCLK). Alternatively, one of the TDM modes can be used to access up to 16 channels on a single TDM data line.

Each output pin has a nominal common-mode dc level of 1.5 V and swings ± 1.27 V for a 0 dBFS digital input signal. A single op amp, third-order, external, low-pass filter is recommended to remove high frequency noise present on the output pins. The use of op amps with low slew rate or low bandwidth can cause high frequency noise and tones to fold down into the audio band; therefore, exercise care in selecting these components.

The voltage at CM, the common-mode reference pin, can be used to bias the external op amps that buffer the output signals (see the Power Supply and Voltage Reference section).

CLOCK SIGNALS

The on-chip phase locked loop (PLL) can be selected to reference the input sample rate from either of the LRCLK pins or 256, 384, 512, or 768 times the sample rate, referenced to the 48 kHz mode from the MCLKI/XI pin. The default at power-up is $256 \times f_s$ from the MCLKI/XI pin. In 96 kHz mode, the master clock frequency stays at the same absolute frequency; therefore, the actual multiplication rate is divided by 2. In 192 kHz mode, the actual multiplication rate is divided by 4. For example, if a device in the AD193x family is programmed in $256 \times f_s$ mode, the frequency of the master clock input is 256×48 kHz = 12.288 MHz. If the AD193x is then switched to 96 kHz operation (by writing to the SPI port), the frequency of the master clock should remain at 12.288 MHz, which becomes $128 \times f_s$. In 192 kHz mode, this becomes $64 \times f_s$.

The internal clock for the ADCs is $256 \times f_s$ for all clock modes. The internal clock for the DACs varies by mode: $512 \times f_s$ (48 kHz mode), $256 \times f_s$ (96 kHz mode), or $128 \times f_s$ (192 kHz mode). By default, the on-board PLL generates this internal master clock from an external clock. A direct $512 \times f_s$ (referenced to 48 kHz mode) master clock can be used for either the ADCs or DACs if selected in the PLL and Clock Control 1 register.

Note that it is not possible to use a direct clock for the ADCs set to the 192 kHz mode. It is required that the on-chip PLL be used in this mode.

The PLL can be powered down in the PLL and Clock Control 0 register. To ensure reliable locking when changing PLL modes, or if the reference clock is unstable at power-on, power down the PLL and then power it back up when the reference clock stabilizes.

The internal master clock can be disabled in the PLL and Clock Control 0 register to reduce power dissipation when the [AD1938](#) is idle. The clock should be stable before it is enabled. Unless a standalone mode is selected (see the Serial Control Port section), the clock is disabled by reset and must be enabled by writing to the SPI port for normal operation.

To maintain the highest performance possible, limit the clock jitter of the internal master clock signal to less than a 300 ps rms time interval error (TIE). Even at these levels, extra noise or tones can appear in the DAC outputs if the jitter spectrum contains large spectral peaks. If the internal PLL is not used, it is best to use an independent crystal oscillator to generate the master clock. In addition, it is especially important that the clock signal not pass through an FPGA, CPLD, or other large digital chip (such as a DSP) before being applied to the [AD1938](#). In most cases, this induces clock jitter due to the sharing of common power and ground connections with other unrelated digital output signals. When the PLL is used, jitter in

the reference clock is attenuated above a certain frequency depending on the loop filter.

RESET AND POWER-DOWN

The function of the $\overline{\text{RST}}$ pin sets all the control registers to their default settings. To avoid pops, reset does not power down the analog outputs. After $\overline{\text{RST}}$ is deasserted, and the PLL acquires lock condition, an initialization routine runs inside the AD1938. This initialization lasts for approximately 256 master clock cycles.

The power-down bits in the PLL and Clock Control 0, DAC Control 1, and ADC Control 1 registers power down the respective sections. All other register settings are retained. To guarantee proper start up, the $\overline{\text{RST}}$ pin should be pulled low by an external resistor.

SERIAL CONTROL PORT

The AD1938 has an SPI control port that permits programming and reading back of the internal control registers for the ADCs, DACs, and clock system. There is also a standalone mode available for operation without serial control that is configured

at reset using the serial control pins. All registers are set to default, except the internal master clock enable which is set to 1, and ADC BCLK and LRCLK master/slave is set by the COUT pin. Refer to Table 11 for details. Standalone mode only supports stereo mode with an I²S data format and 256 f_s master clock rate. It is recommended to use a weak pull-up resistor on $\overline{\text{CLATCH}}$ in applications that have a microcontroller. This pull-up resistor ensures that the AD1938 recognizes the presence of a microcontroller.

The SPI control port of the AD1938 is a 4-wire serial control port. The format is similar to the Motorola SPI format except the input data-word is 24 bits wide. The serial bit clock and latch can be completely asynchronous to the sample rate of the ADCs and DACs. Figure 11 shows the format of the SPI signal. The first byte is a global address with a read/write bit. For the AD1938, the address is 0x04, shifted left one bit due to the $\overline{\text{R/W}}$ bit. The second byte is the AD1938 register address and the third byte is the data.

Table 11. Standalone Mode Selection

| ADC Clocks | CIN | COUT | CCLK | CLATCH |
|------------|-----|------|------|--------|
| Slave | 0 | 0 | 0 | 0 |
| Master | 0 | 1 | 0 | 0 |

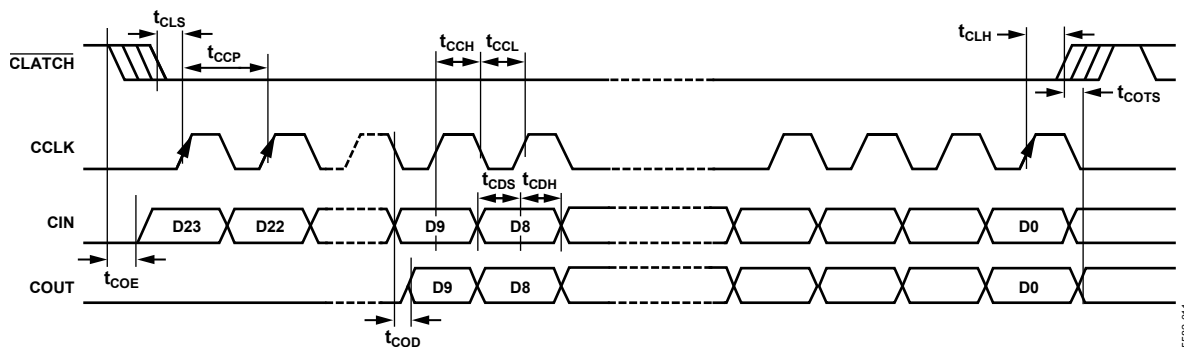

Figure 11. Format of SPI Signal

05592-011

POWER SUPPLY AND VOLTAGE REFERENCE

The AD1938 is designed for 3.3 V supplies. Separate power supply pins are provided for the analog and digital sections. These pins should be bypassed with 100 nF ceramic chip capacitors, as close to the pins as possible, to minimize noise pickup. A bulk aluminum electrolytic capacitor of at least 22 μF should also be provided on the same PCB as the codec. For critical applications, improved performance is obtained with separate supplies for the analog and digital sections. If this is not possible, it is recommended that the analog and digital supplies be isolated by means of a ferrite bead in series with each supply. It is important that the analog supply be as clean as possible.

All digital inputs are compatible with TTL and CMOS levels. All outputs are driven from the 3.3 V DVDD supply and are compatible with TTL and 3.3 V CMOS levels.

The ADC and DAC internal voltage reference (VREF) is brought out on FILTR and should be bypassed as close as possible to the chip, with a parallel combination of 10 μF and 100 nF. Any external current drawn should be limited to less than 50 μA .

The internal reference can be disabled in the PLL and Clock Control 1 register, and FILTR can be driven from an external source. This configuration can be used to scale the DAC output to the clipping level of a power amplifier based on its power supply voltage. The ADC input gain varies by the inverse ratio. The total gain from ADC input to DAC output remains constant.

The CM pin is the internal common-mode reference. It should be bypassed as close as possible to the chip, with a parallel combination of 47 μF and 100 nF. This voltage can be used to bias external op amps to the common-mode voltage of the input and output signal pins. The output current should be limited to less than 0.5 mA source and 2 mA sink.

SERIAL DATA PORTS—DATA FORMAT

The eight DAC channels use a common serial bit clock (DBCLK) and a common left-right framing clock (DLRCLK) in the serial data port. The four ADC channels use a common serial bit clock (ABCLK) and left-right framing clock (ALRCLK) in the serial data port. The clock signals are all synchronous with the sample rate. The normal stereo serial modes are shown in Figure 23.

The ADC and DAC serial data modes default to I²S. The ports can also be programmed for left-justified, right-justified, and TDM modes. The word width is 24 bits by default and can be programmed for 16 or 20 bits. The DAC serial formats are programmable according to the DAC Control 0 register. The polarity of the DBCLK and DLRCLK is programmable according to DAC Control 1 register. The ADC serial formats and serial clock polarity are programmable according to ADC Control 1 register. Both DAC and ADC serial ports are programmable to become the bus masters according to DAC Control 1 register

and ADC Control 2 register. By default, both ADC and DAC serial ports are in the slave mode.

TIME-DIVISION MULTIPLEXED (TDM) MODES

The AD1938 serial ports also have several different TDM serial data modes. The first and most commonly used configurations are shown in Figure 12 and Figure 13. In Figure 12, the ADC serial port outputs one data stream consisting of four on-chip ADCs followed by four unused slots. In Figure 13, the eight on-chip DAC data slots are packed into one TDM stream. In this mode, both DBCLK and ABCLK are 256 f_s .

The I/O pins of the serial ports are defined according to the serial mode selected. For a detailed description of the function of each pin in TDM and auxiliary modes, see Table 12.

The AD1938 allows systems with more than eight DAC channels to be easily configured by the use of an auxiliary serial data port. The DAC TDM-AUX mode is shown in Figure 14. In this mode, the AUX channels are the last four slots of the TDM data stream. These slots are extracted and output to the AUX serial port. It should be noted that due to the high DBCLK frequency, this mode is available only in the 48 kHz/44.1 kHz/32 kHz sample rate.

The AD1938 also allows system configurations with more than four ADC channels as shown in Figure 15 and Figure 16 that show using 8 ADCs and 16 ADCs, respectively. Again, due to the high ABCLK frequency, this mode is available only in the 48 kHz/44.1 kHz/32 kHz sample rate.

Combining the AUX ADC and DAC modes results in a system configuration of 8 ADCs and 12 DACs. The system, then, consists of two external stereo ADCs, two external stereo DACs, and one AD1938. This mode is shown in Figure 17 (combined AUX ADC and DAC modes).

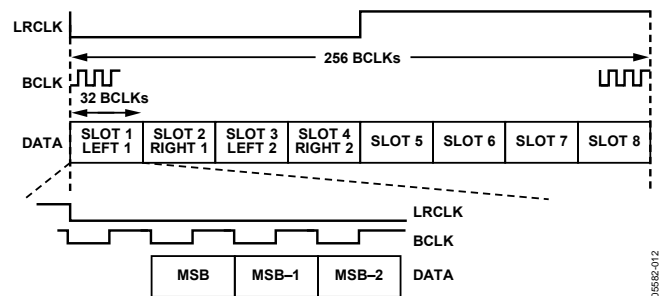

Figure 12. ADC TDM (8-Channel I²S Mode)

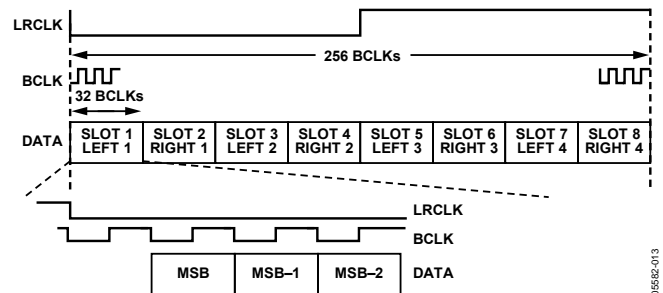

Figure 13. DAC TDM (8-Channel I²S Mode)

Table 12. Pin Function Changes in TDM-AUX Modes

| Mnemonic | Stereo Modes | TDM Modes | AUX Modes |
|----------|----------------------------|--|--------------------------------------|
| ASDATA1 | ADC1 Data Out | ADC TDM Data Out | TDM Data Out |
| ASDATA2 | ADC2 Data Out | ADC TDM Data In | AUX Data Out 1 (to Ext. DAC 1) |
| DSDATA1 | DAC1 Data In | DAC TDM Data In | TDM Data In |
| DSDATA2 | DAC2 Data In | DAC TDM Data Out | AUX Data In 1 (from Ext. ADC 1) |
| DSDATA3 | DAC3 Data In | DAC TDM Data In 2 (Dual-Line Mode) | AUX Data In 2 (from Ext. ADC 2) |
| DSDATA4 | DAC4 Data In | DAC TDM Data Out 2 (Dual-Line Mode) | AUX Data Out 2 (to Ext. DAC 2) |
| ALRCLK | ADC LRCLK In/ADC LRCLK Out | ADC TDM Frame Sync In/DC TDM Frame Sync Out | TDM Frame Sync In/TDM Frame Sync Out |
| ABCLK | ADC BCLK In/ADC BCLK Out | ADC TDM BCLK In/ADC TDM BCLK Out | TDM BCLK In/TDM BCLK Out |
| DLRCLK | DAC LRCLK In/DAC LRCLK Out | DAC TDM Frame Sync In/DAC TDM Frame Sync Out | AUX LRCLK In/AUX LRCLK Out |
| DBCLK | DAC BCLK In/DAC BCLK Out | DAC TDM BCLK In/DAC TDM BCLK Out | AUX BCLK In/AUX BCLK Out |

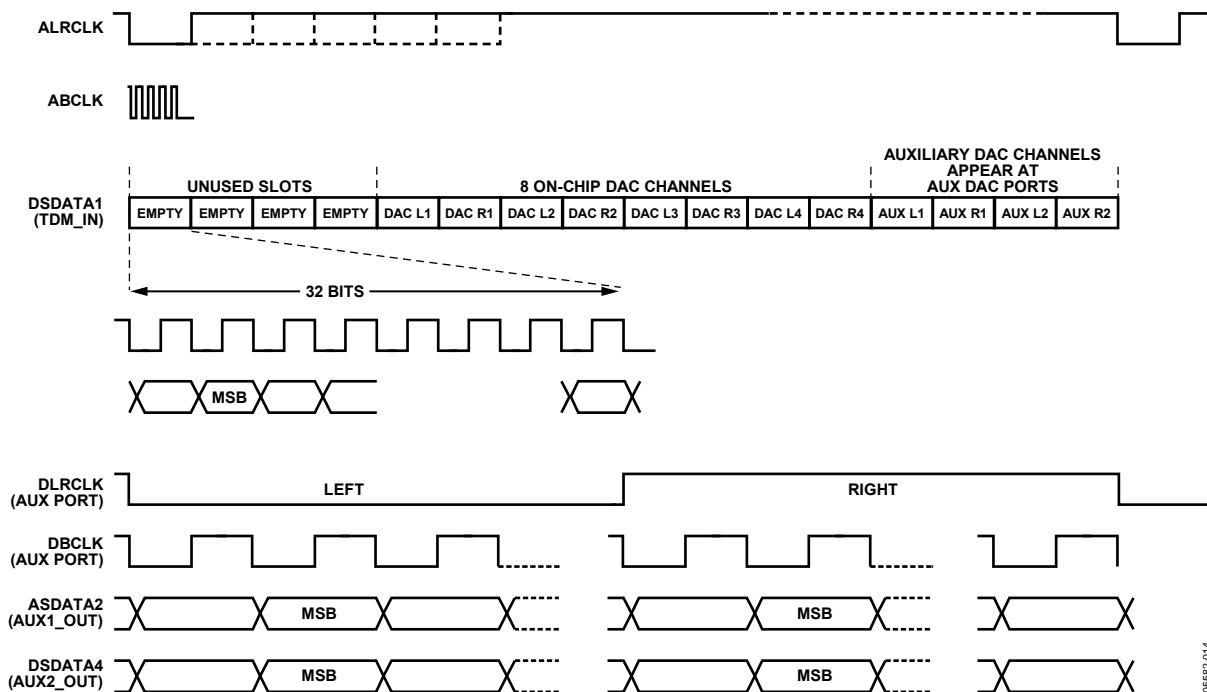

Figure 14. 16-Channel AUX DAC Mode

06562-014

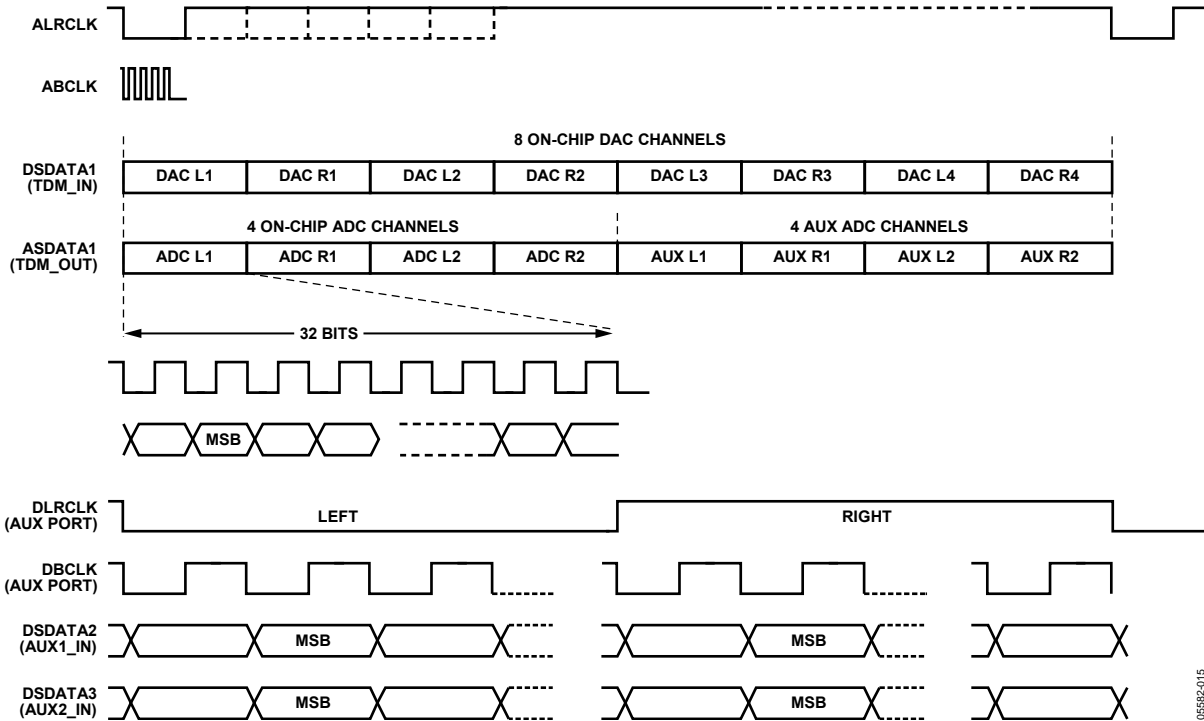

Figure 15. 8-Channel AUX ADC Mode

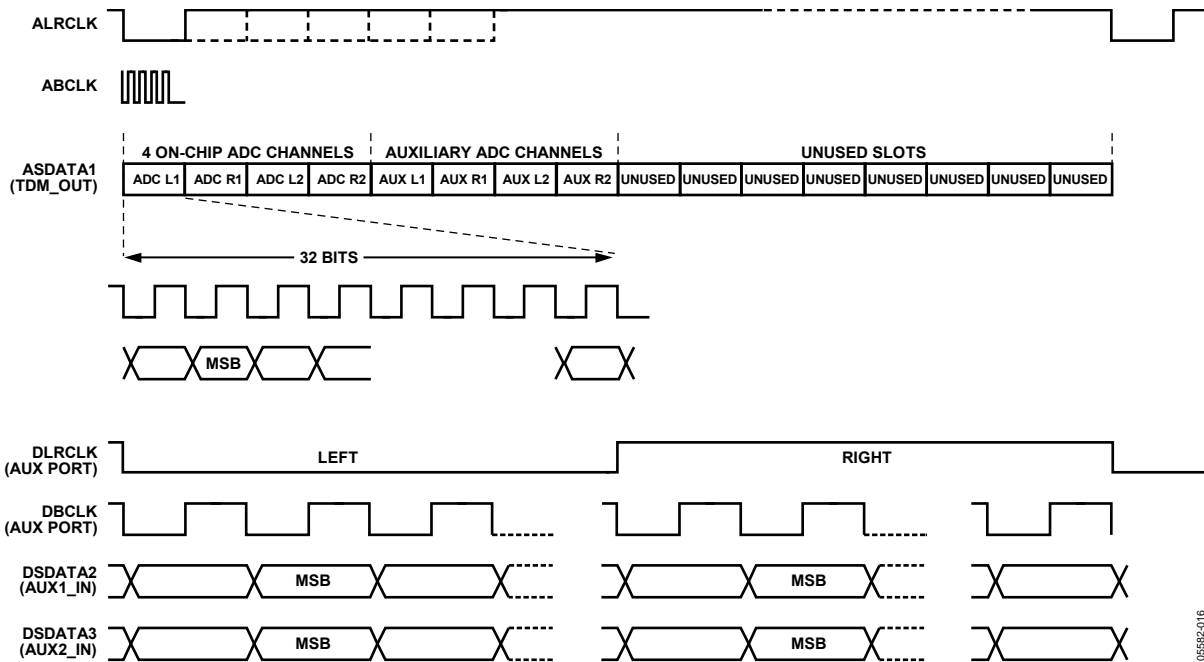

Figure 16. 16-Channel AUX ADC Mode

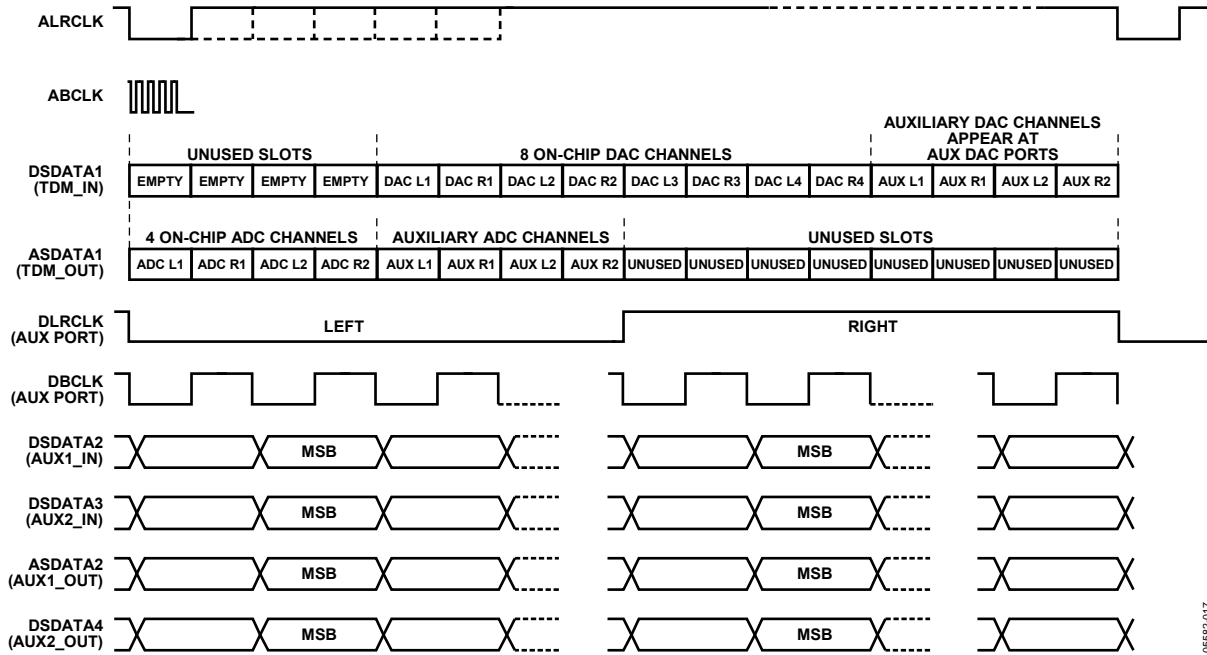

Figure 17. Combined AUX DAC and ADC Mode

05582-017

DAISY-CHAIN MODE

The AD1938 allows a daisy-chain configuration to expand the system to 8 ADCs and 16 DACs (see Figure 18). In this mode, the DBCLK frequency is 512 fs. The first eight slots of the DAC TDM data stream belong to the first AD1938 in the chain and the last eight slots belong to the second AD1938. The second AD1938 is the device attached to the DSP TDM port.

To accommodate 16 channels at a 96 kHz sample rate, the AD1938 can be configured into a dual-line TDM mode as shown in Figure 19. This mode allows a slower DBCLK than normally required by the one-line TDM mode.

Again, the first four channels of each TDM input belong to the first AD1938 in the chain and the last four channels belong to the second AD1938.

The dual-line TDM mode can also be used to send data at a 192 kHz sample rate into the AD1938 as shown in Figure 20.

There are two configurations for the ADC port to work in daisy-chain mode. The first one is with an ABCLK at 256 fs shown in Figure 21. The second configuration is shown in Figure 22. Note that in the 512 fs ABCLK mode, the ADC channels occupy the first eight slots; the second eight slots are empty. The TDM_IN of the first AD1938 must be grounded in all modes of operation.

The I/O pins of the serial ports are defined according to the serial mode selected. See Table 13 for a detailed description of the function of each pin. See Figure 26 for a typical AD1938 configuration with two external stereo DACs and two external stereo ADCs.

Figure 23 through Figure 25 show the serial mode formats. For maximum flexibility, the polarity of LRCLK and BCLK are programmable. In these figures, all of the clocks are shown with their normal polarity. The default mode is I²S.

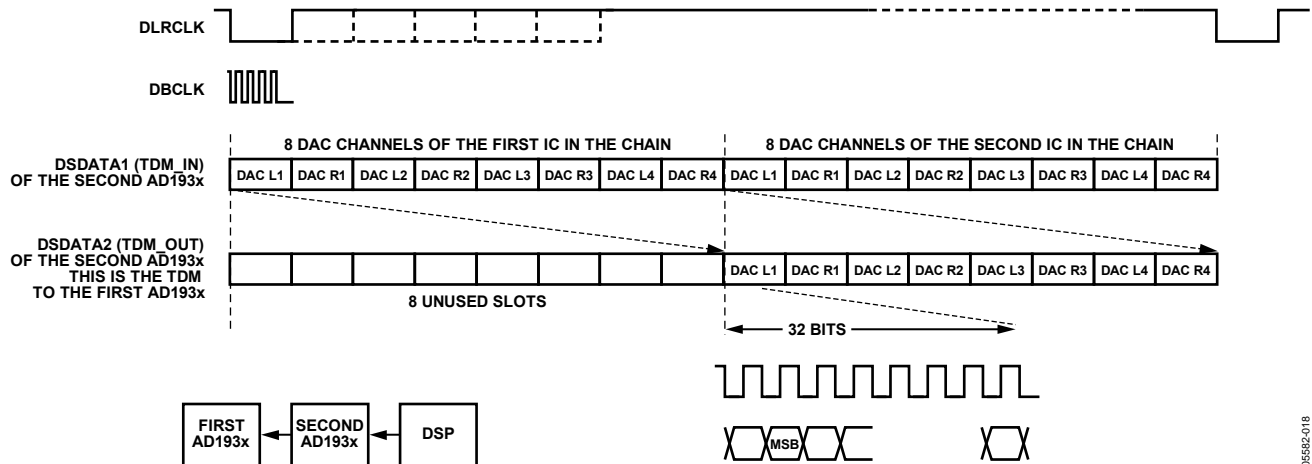
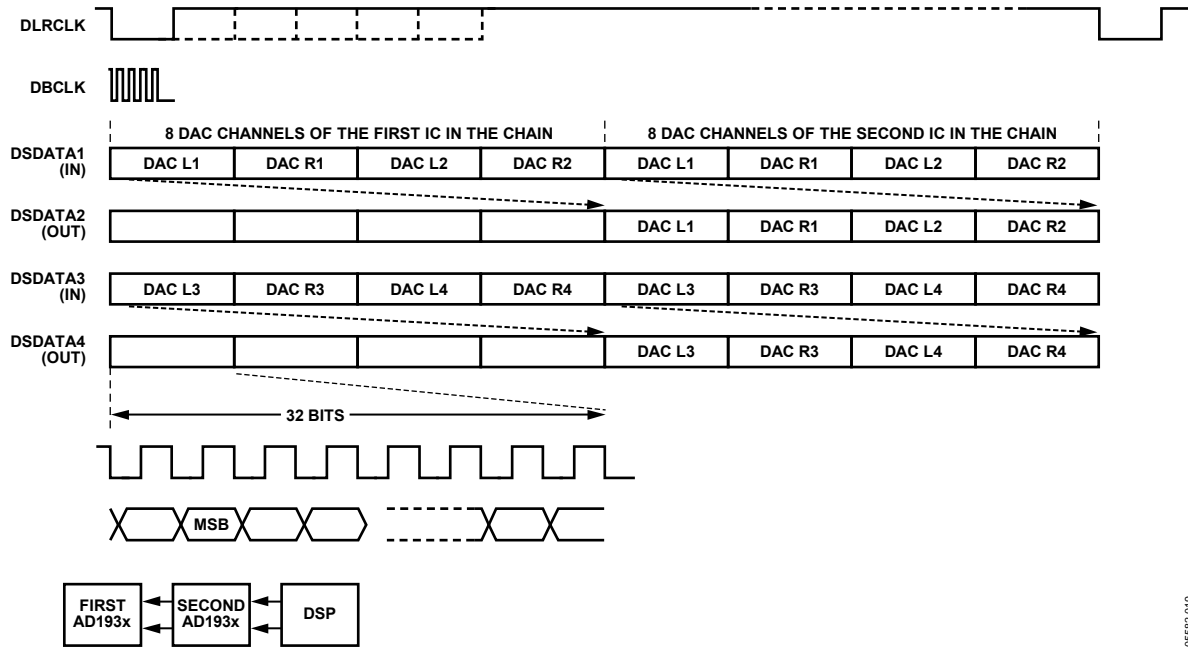

Figure 18. Single-Line DAC TDM Daisy-Chain Mode (Applicable to 48 kHz Sample Rate, 16-Channel, Two-AD1938 Daisy Chain)

05682-018



05592-019

Figure 19. Dual-Line DAC TDM Mode (Applicable to 96 kHz Sample Rate, 16-Channel, Two-AD1938 Daisy Chain); DSDATA3 and DSDATA4 Are the Daisy Chain

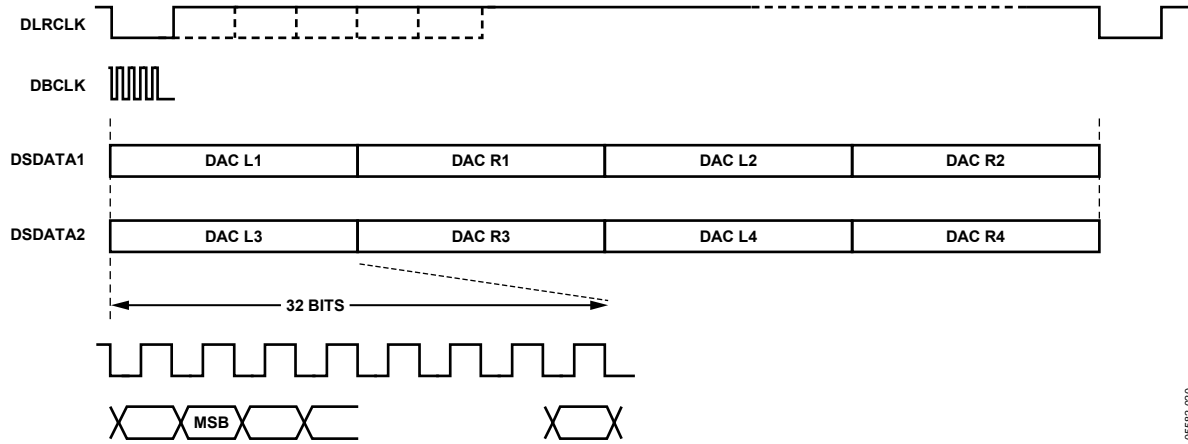

05592-020

Figure 20. Dual-Line DAC TDM Mode (Applicable to 192 kHz Sample Rate, 8-Channel Mode)

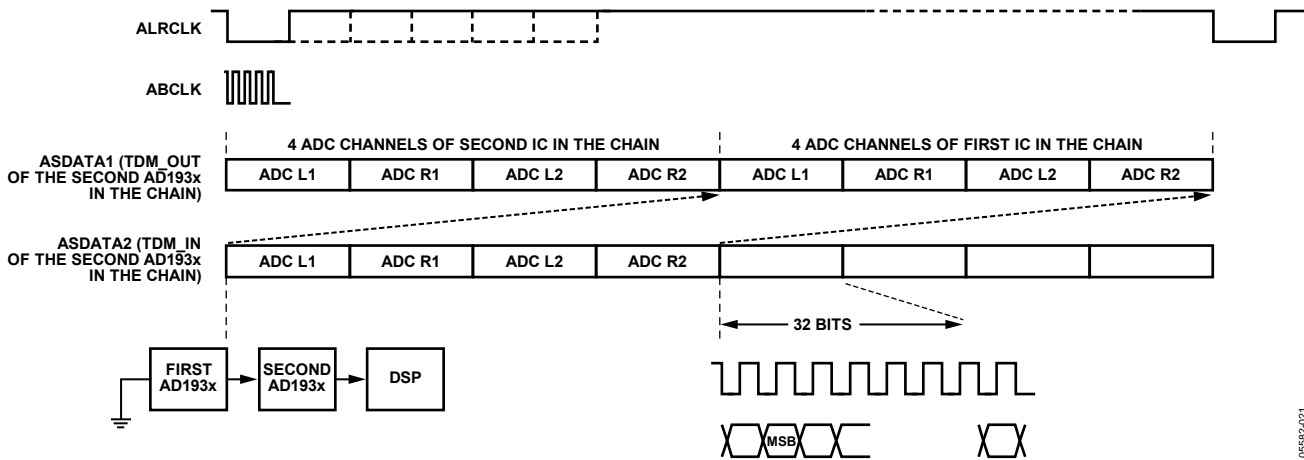

05592-021

Figure 21. ADC TDM Daisy-Chain Mode (256 fs BCLK, Two-AD1938 Daisy Chain)

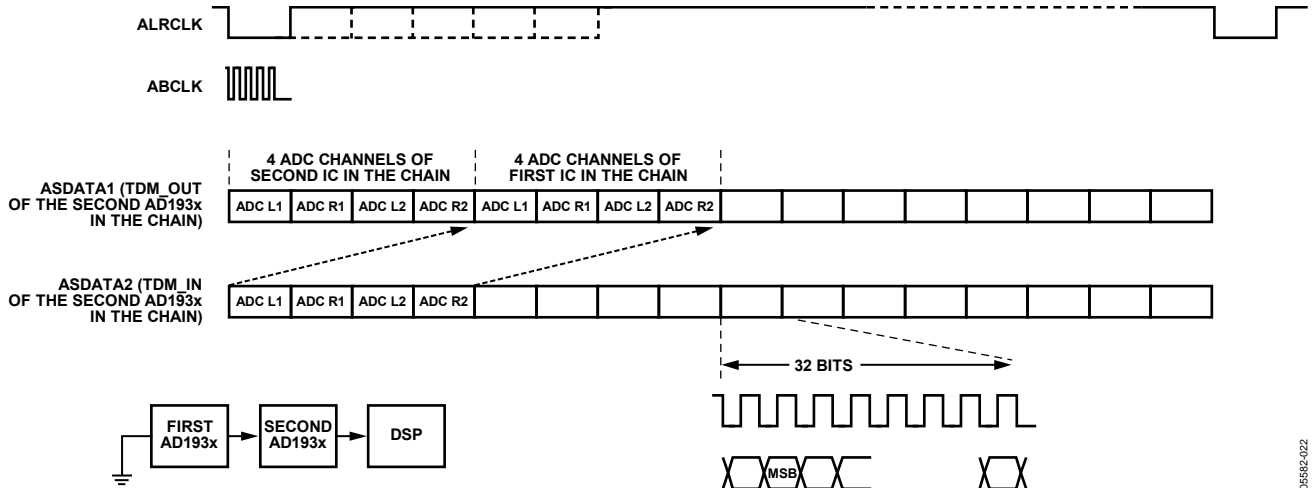
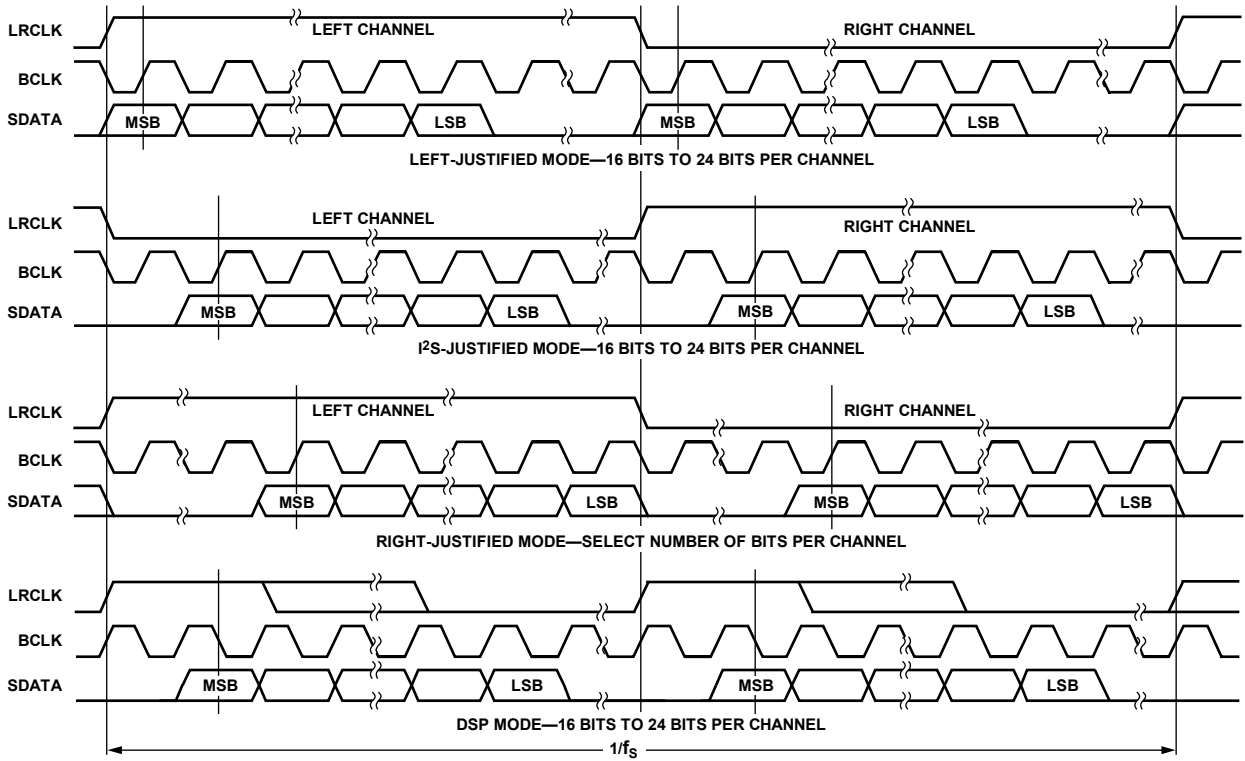

Figure 22. ADC TDM Daisy-Chain Mode (512 f_s BCLK, Two-AD1938x Daisy Chain)



- NOTES
1. DSP MODE DOES NOT IDENTIFY CHANNEL.
 2. LRCLK NORMALLY OPERATES AT f_s EXCEPT FOR DSP MODE WHICH IS $2 \times f_s$.
 3. BCLK FREQUENCY IS NORMALLY $64 \times$ LRCLK BUT MAY BE OPERATED IN BURST MODE.

Figure 23. Stereo Serial Modes

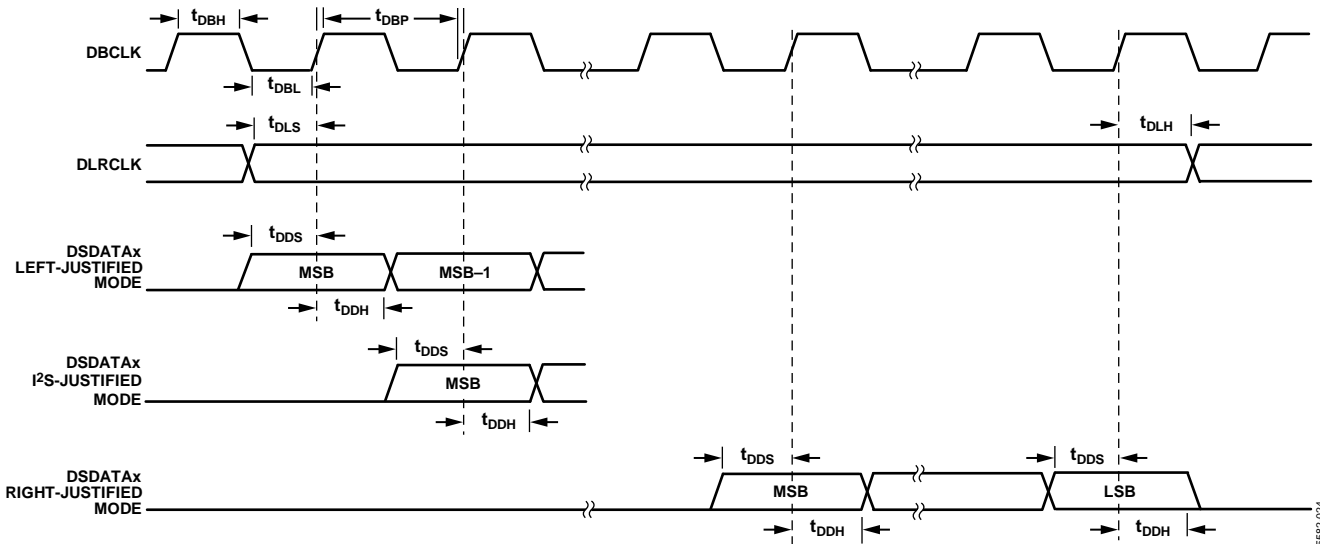

Figure 24. DAC Serial Timing

05582-024

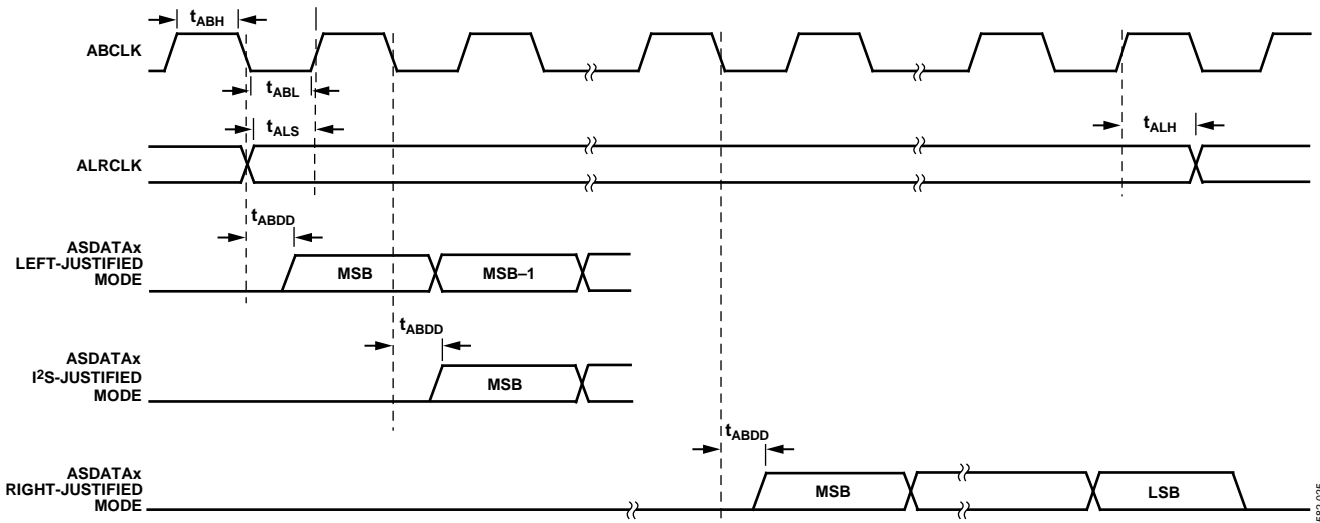

Figure 25. ADC Serial Timing

05582-025

Table 13. Pin Function Changes in TDM and AUX Modes (Replication of Table 12)

| Mnemonic | Stereo Modes | TDM Modes | AUX Modes |
|----------|----------------------------|--|--------------------------------------|
| ASDATA1 | ADC1 Data Out | ADC TDM Data Out | TDM Data Out |
| ASDATA2 | ADC2 Data Out | ADC TDM Data In | AUX Data Out 1 (to Ext. DAC 1) |
| DSDATA1 | DAC1 Data In | DAC TDM Data In | TDM Data In |
| DSDATA2 | DAC2 Data In | DAC TDM Data Out | AUX Data In 1 (from Ext. ADC 1) |
| DSDATA3 | DAC3 Data In | DAC TDM Data In 2 (Dual-Line Mode) | AUX Data In 2 (from Ext. ADC 2) |
| DSDATA4 | DAC4 Data In | DAC TDM Data Out 2 (Dual-Line Mode) | AUX Data Out 2 (to Ext. DAC 2) |
| ALRCLK | ADC LRCLK In/ADC LRCLK Out | ADC TDM Frame Sync In/DC TDM Frame Sync Out | TDM Frame Sync In/TDM Frame Sync Out |
| ABCLK | ADC BCLK In/ADC BCLK Out | ADC TDM BCLK In/ADC TDM BCLK Out | TDM BCLK In/TDM BCLK Out |
| DLRCLK | DAC LRCLK In/DAC LRCLK Out | DAC TDM Frame Sync In/DAC TDM Frame Sync Out | AUX LRCLK In/AUX LRCLK Out |
| DBCLK | DAC BCLK In/DAC BCLK Out | DAC TDM BCLK In/DAC TDM BCLK Out | AUX BCLK In/AUX BCLK Out |

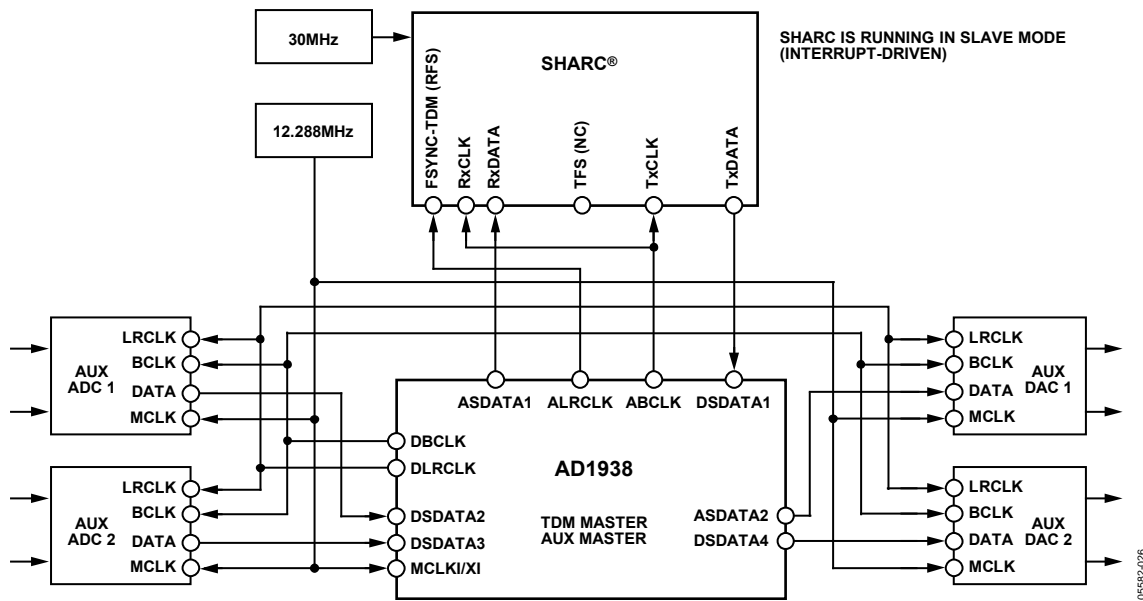

Figure 26. Example of AUX Mode Connection to SHARC (AD1938 as TDM Master/AUX Master Shown)

CONTROL REGISTERS

DEFINITIONS

The global address for the AD1938 is 0x04, shifted left one bit due to the R/W bit. All registers are reset to 0, except for the DAC volume registers that are set to full volume.

Note that the first setting in each control register parameter is the default setting.

Table 14. Register Format

| | Global Address | R/W | Register Address | Data |
|-----|----------------|-----|------------------|------|
| Bit | 23:17 | 16 | 15:8 | 7:0 |

Table 15. Register Addresses and Functions

| Address | Function |
|---------|------------------------------|
| 0 | PLL and Clock Control 0 |
| 1 | PLL and Clock Control 1 |
| 2 | DAC Control 0 |
| 3 | DAC Control 1 |
| 4 | DAC Control 2 |
| 5 | DAC individual channel mutes |
| 6 | DAC L1 volume control |
| 7 | DAC R1 volume control |
| 8 | DAC L2 volume control |
| 9 | DAC R2 volume control |
| 10 | DAC L3 volume control |
| 11 | DAC R3 volume control |
| 12 | DAC L4 volume control |
| 13 | DAC R4 volume control |
| 14 | ADC Control 0 |
| 15 | ADC Control 1 |
| 16 | ADC Control 2 |

PLL AND CLOCK CONTROL REGISTERS

Table 16. PLL and Clock Control Register 0

| Bit | Value | Function | Description |
|-----|-------|--|--|
| 0 | 0 | Normal operation | PLL power-down |
| | 1 | Power-down | |
| 2:1 | 00 | INPUT 256 ($\times 44.1$ kHz or 48 kHz) | MCLKI/XI pin functionality (PLL active), master clock rate setting |
| | 01 | INPUT 384 ($\times 44.1$ kHz or 48 kHz) | |
| | 10 | INPUT 512 ($\times 44.1$ kHz or 48 kHz) | |
| | 11 | INPUT 768 ($\times 44.1$ kHz or 48 kHz) | |
| 4:3 | 00 | XTAL oscillator enabled | MCLKO/XO pin, master clock rate setting |
| | 01 | $256 \times f_s$ VCO output | |
| | 10 | $512 \times f_s$ VCO output | |
| | 11 | Off | |
| 6:5 | 00 | MCLKI/XI | PLL input |
| | 01 | DLRCLK | |
| | 10 | ALRCLK | |
| | 11 | Reserved | |
| 7 | 0 | Disable: ADC and DAC idle | Internal master clock enable |
| | 1 | Enable: ADC and DAC active | |

Table 17. PLL and Clock Control Register 1

| Bit | Value | Function | Description |
|-----|-------|------------|--------------------------------|
| 0 | 0 | PLL clock | DAC clock source select |
| | 1 | MCLK | |
| 1 | 0 | PLL clock | ADC clock source select |
| | 1 | MCLK | |
| 2 | 0 | Enabled | On-chip voltage reference |
| | 1 | Disabled | |
| 3 | 0 | Not locked | PLL lock indicator (read-only) |
| | 1 | Locked | |
| 7:4 | 0000 | Reserved | |

DAC CONTROL REGISTERS

Table 18. DAC Control Register 0

| Bit | Value | Function | Description |
|-----|-------|--|----------------------------|
| 0 | 0 | Normal | Power-down |
| | 1 | Power-down | |
| 2:1 | 00 | 32 kHz/44.1 kHz/48 kHz | Sample rate |
| | 01 | 64 kHz/88.2 kHz/96 kHz | |
| | 10 | 128 kHz/176.4 kHz/192 kHz | |
| | 11 | Reserved | |
| 5:3 | 000 | 1 | SDATA delay (BCLK periods) |
| | 001 | 0 | |
| | 010 | 8 | |
| | 011 | 12 | |
| | 100 | 16 | |
| | 101 | Reserved | |
| | 110 | Reserved | |
| | 111 | Reserved | |
| 7:6 | 00 | Stereo (normal) | Serial format |
| | 01 | TDM (daisy chain) | |
| | 10 | DAC AUX mode (ADC-, DAC-, TDM-coupled) | |
| | 11 | Dual-line TDM | |

Table 19. DAC Control Register 1

| Bit | Value | Function | Description |
|-----|-------|-------------------------------------|---------------------------|
| 0 | 0 | Latch in mid cycle (normal) | BCLK active edge (TDM in) |
| | 1 | Latch in at end of cycle (pipeline) | |
| 2:1 | 00 | 64 (2 channels) | BCLKs per frame |
| | 01 | 128 (4 channels) | |
| | 10 | 256 (8 channels) | |
| | 11 | 512 (16 channels) | |
| 3 | 0 | Left low | LRCLK polarity |
| | 1 | Left high | |
| 4 | 0 | Slave | LRCLK master/slave |
| | 1 | Master | |
| 5 | 0 | Slave | BCLK master/slave |
| | 1 | Master | |
| 6 | 0 | DBCLK pin | BCLK source |
| | 1 | Internally generated | |
| 7 | 0 | Normal | BCLK polarity |
| | 1 | Inverted | |

Table 20. DAC Control Register 2

| Bit | Value | Function | Description |
|-----|-------|----------------|--|
| 0 | 0 | Unmute | Master mute |
| | 1 | Mute | |
| 2:1 | 00 | Flat | De-emphasis (32 kHz/44.1 kHz/48 kHz mode only) |
| | 01 | 48 kHz curve | |
| | 10 | 44.1 kHz curve | |
| | 11 | 32 kHz curve | |
| 4:3 | 00 | 24 | Word width |
| | 01 | 20 | |
| | 10 | Reserved | |
| | 11 | 16 | |
| 5 | 0 | Noninverted | DAC output polarity |
| | 1 | Inverted | |
| 7:6 | 00 | Reserved | |

Table 21. DAC Individual Channel Mutes

| Bit | Value | Function | Description |
|-----|-------|----------|------------------|
| 0 | 0 | Unmute | DAC 1 left mute |
| | 1 | Mute | |
| 1 | 0 | Unmute | DAC 1 right mute |
| | 1 | Mute | |
| 2 | 0 | Unmute | DAC 2 left mute |
| | 1 | Mute | |
| 3 | 0 | Unmute | DAC 2 right mute |
| | 1 | Mute | |
| 4 | 0 | Unmute | DAC 3 left mute |
| | 1 | Mute | |
| 5 | 0 | Unmute | DAC 3 right mute |
| | 1 | Mute | |
| 6 | 0 | Unmute | DAC 4 left mute |
| | 1 | Mute | |
| 7 | 0 | Unmute | DAC 4 right mute |
| | 1 | Mute | |

Table 22. DAC Volume Controls

| Bit | Value | Function | Description |
|-----|----------|------------------|--------------------|
| 7:0 | 0 | No attenuation | DAC volume control |
| | 1 to 254 | -3/8 dB per step | |
| | 255 | Full attenuation | |

ADC CONTROL REGISTERS

Table 23. ADC Control Register 0

| Bit | Value | Function | Description |
|-----|-------|---------------------------|--------------------|
| 0 | 0 | Normal | Power-down |
| | 1 | Power down | |
| 1 | 0 | Off | High-pass filter |
| | 1 | On | |
| 2 | 0 | Unmute | ADC L1 mute |
| | 1 | Mute | |
| 3 | 0 | Unmute | ADC R1 mute |
| | 1 | Mute | |
| 4 | 0 | Unmute | ADC L2 mute |
| | 1 | Mute | |
| 5 | 0 | Unmute | ADC R2 mute |
| | 1 | Mute | |
| 7:6 | 00 | 32 kHz/44.1 kHz/48 kHz | Output sample rate |
| | 01 | 64 kHz/88.2 kHz/96 kHz | |
| | 10 | 128 kHz/176.4 kHz/192 kHz | |
| | 11 | Reserved | |

Table 24. ADC Control Register 1

| Bit | Value | Function | Description |
|-----|----------|--|----------------------------|
| 1:0 | 00 | 24 | Word width |
| | 01 | 20 | |
| | 10 | Reserved | |
| | 11 | 16 | |
| 4:2 | 000 | 1 | SDATA delay (BCLK periods) |
| | 001 | 0 | |
| | 010 | 8 | |
| | 011 | 12 | |
| | 100 | 16 | |
| | 101 | Reserved | |
| | 110 | Reserved | |
| 111 | Reserved | | |
| 6:5 | 00 | Stereo | Serial format |
| | 01 | TDM (daisy chain) | |
| | 10 | ADC AUX mode (ADC-, DAC-, TDM-coupled) | |
| | 11 | Reserved | |
| 7 | 0 | Latch in mid cycle (normal) | BCLK active edge (TDM in) |
| | 1 | Latch in at end of cycle (pipeline) | |

Table 25. ADC Control Register 2

| Bit | Value | Function | Description |
|-----|-------|---|--------------------|
| 0 | 0 | 50/50 (allows 32, 24, 20, or 16 bit clocks (BCLKs) per channel) | LRCLK format |
| | 1 | Pulse (32 BCLKs per channel) | |
| 1 | 0 | Drive out on falling edge (DEF) | BCLK polarity |
| | 1 | Drive out on rising edge | |
| 2 | 0 | Left low | LRCLK polarity |
| | 1 | Left high | |
| 3 | 0 | Slave | LRCLK master/slave |
| | 1 | Master | |
| 5:4 | 00 | 64 | BCLKs per frame |
| | 01 | 128 | |
| | 10 | 256 | |
| | 11 | 512 | |
| 6 | 0 | Slave | BCLK master/slave |
| | 1 | Master | |
| 7 | 0 | ABCLK pin | BCLK source |
| | 1 | Internally generated | |

ADDITIONAL MODES

The AD1938 offers several additional modes for board level design enhancements. To reduce the EMI in board level design, serial data can be transmitted without an explicit BCLK. See Figure 27 for an example of a DAC TDM data transmission mode that does not require high speed DBCLK. This configuration is applicable when the AD1938 master clock is generated by the PLL with the DLRCLK as the PLL reference frequency.

To relax the requirement for the setup time of the AD1938 in cases of high speed TDM data transmission, the AD1938 can latch in the data using the falling edge of DBCLK. This effectively dedicates the entire BCLK period to the setup time. This mode is useful in cases where the source has a large delay time in the serial data driver. Figure 28 shows this pipeline mode of data transmission.

Both the BCLK-less and pipeline modes are available on the ADC serial data port.

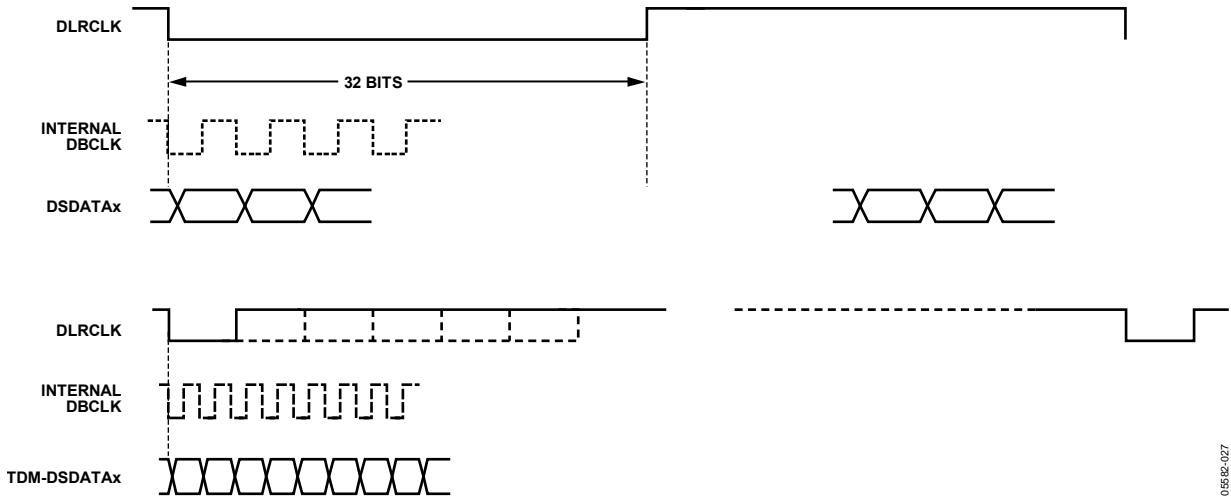

Figure 27. Serial DAC Data Transmission in TDM Format Without DBCLK
(Applicable Only If PLL Locks to DLRCLK. This Mode Is Also Available in the ADC Serial Data Port.)

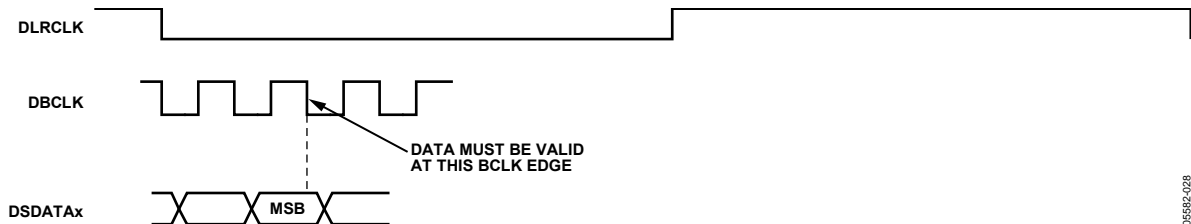

Figure 28. I²S Pipeline Mode in DAC Serial Data Transmission
(Applicable in Stereo and TDM, Useful for High Frequency TDM Transmission. This Mode Is Also Available in the ADC Serial Data Port.)

APPLICATIONS CIRCUITS

Typical applications circuits are shown in Figure 29 through Figure 32. Figure 29 shows a typical ADC input filter circuit. Recommended loop filters for LR clock and master clock as the PLL reference are shown in Figure 30. Output filters for the DAC outputs are shown in Figure 31 and Figure 32 for the noninverting and inverting cases.

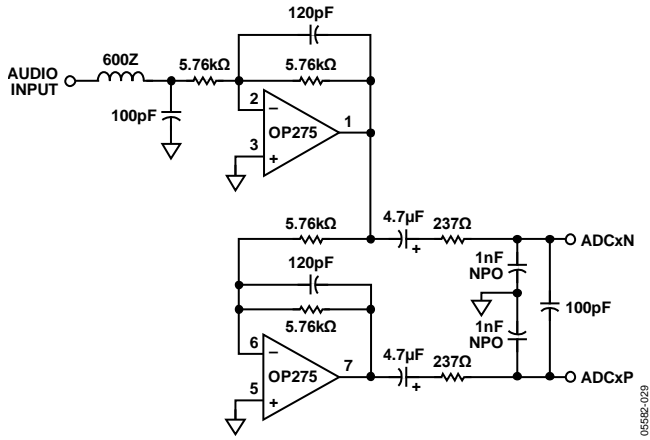

Figure 29. Typical ADC Input Filter Circuit

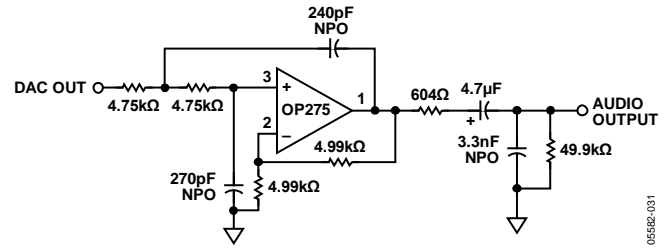

Figure 31. Typical DAC Output Filter Circuit (Single-Ended, Noninverting)

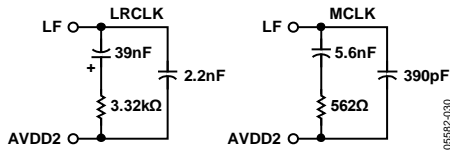

Figure 30. Recommended Loop Filters for LRCLK and MCLK PLL Reference

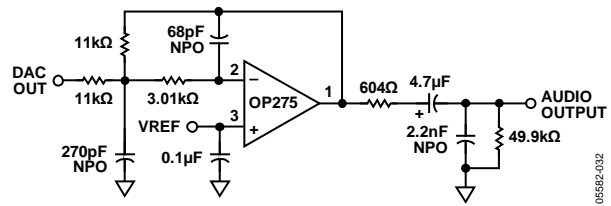
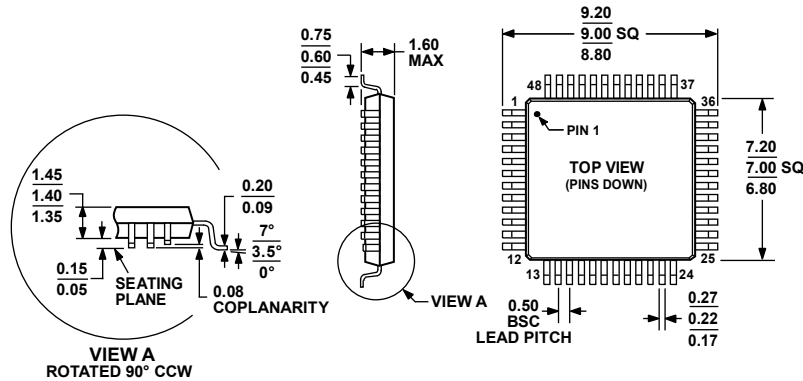

Figure 32. Typical DAC Output Filter Circuit (Single-Ended, Inverting)

OUTLINE DIMENSIONS



COMPLIANT TO JEDEC STANDARDS MS-026-BBC

Figure 33. 48-Lead Low Profile Quad Flat Package [LQFP] (ST-48)

Dimensions shown in millimeters

051706-A

ORDERING GUIDE

| Model ^{1, 2, 3} | Temperature Range | Package Description | Package Option |
|--------------------------|-------------------|---------------------------------|----------------|
| AD1938YSTZ | -40°C to +105°C | 48-Lead LQFP | ST-48 |
| AD1938YSTZRL | -40°C to +105°C | 48-Lead LQFP, 13" Tape and Reel | ST-48 |
| AD1938WBSTZ | -40°C to +105°C | 48-Lead LQFP | ST-48 |
| AD1938WBSTZ-RL | -40°C to +105°C | 48-Lead LQFP, 13" Tape and Reel | ST-48 |
| EVAL-AD1938AZ | | Evaluation Board | |

¹ Z = RoHS Compliant Part.

² For the AD1938YSTZ, AD1938YSTZRL, AD1938WBSTZ, and AD1938WBSTZ-RL: single-ended output; SPI control port.

³ W = Qualified for Automotive Applications.

AUTOMOTIVE PRODUCTS

The [AD1938WBSTZ](#) and [AD1938WBSTZ-RL](#) models are available with controlled manufacturing to support the quality and reliability requirements of automotive applications. Note that these automotive models may have specifications that differ from the commercial models; therefore, designers should review the Specifications section of this data sheet carefully. Only the automotive grade products shown are available for use in automotive applications. Contact your local Analog Devices account representative for specific product ordering information and to obtain the specific Automotive Reliability reports for these models.

NOTES