



SERIES 77
AS85049 Boots



M85049/141 Right Angle Heat Shrink Boot



AS85049 lipped, right angle heat shrink boots provide mechanical and environmental protection from damage and debris. AS85049 straight boots are made in accordance with AS85049 and fit standard boot adapters for circular connectors. All adhesive lined and unlined shrink boots are RoHS compliant. Shrink boots are water-tight when equipped with factory installed or user-installed adhesive. Lipped boots lock into boot groove located on adapter and can be ordered with potting holes to fit your requirements. Choose boot size based on adapter diameter and cable diameter.

B

How to Order						
Sample Part Number	M85049/141	-03	H	C	D	P
Product Series	M85049/141 = right angle AS85049 boot					
Dash No.	01, 02, 03, 04, 05, 06, 07, 08; see dimension table					
Material	A, B, G, H; see material table					
Adhesive Option	C = adhesive lined, see adhesive table U = no adhesive					
Drain Holes	D = drain holes Omit for none					
Injection-Vent Ports	P = injection-vent port Omit for none					

Material			
Material	Compound	Material Description	Color Code
A	2071	Polyolefin Semi-Rigid	White
B	2040	Polyolefin Flexible	Red
G	2010	Polyolefin	Green
H	2025	Elastomeric	Blue

Adhesive		
Code	Material	Description
C	Material A, G, H	-55° to +125°C Hot Melt adhesive
	Material B	-55° to +70°C Zero Halogen/Hot Melt
For applications exposed to temperatures reaching 150°C contact the factory		

NOTES

1. See bag identification for matching boot number, no number on boot. See part number development for full description
2. Encircled material letter designator located on O.D. approximately mid length along the 'J' end see part number development for full description
3. Recovered dimension apply to unrestricted recovery. Dimensions may differ than shown when boots are installed over assembly.



SERIES 77
AS85049 Boots



M85049/141 Right Angle Heat Shrink Boot

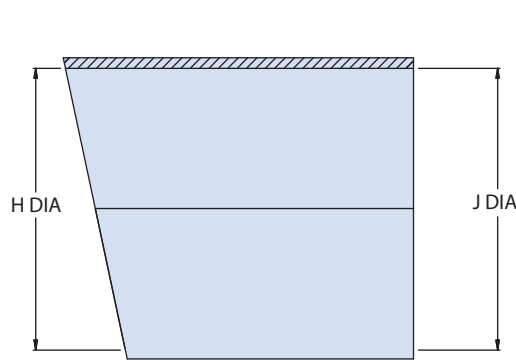

AS SUPPLIED

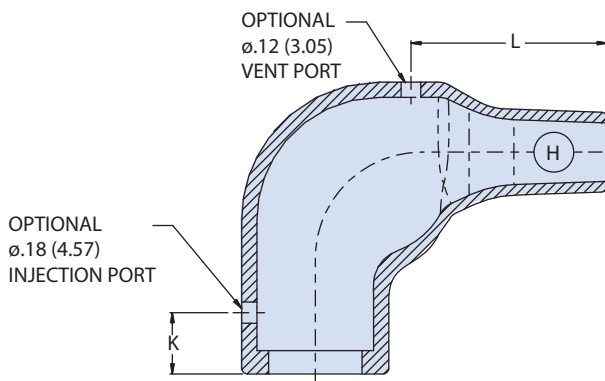

AS RECOVERED WITH INJECTION-VENT PORT

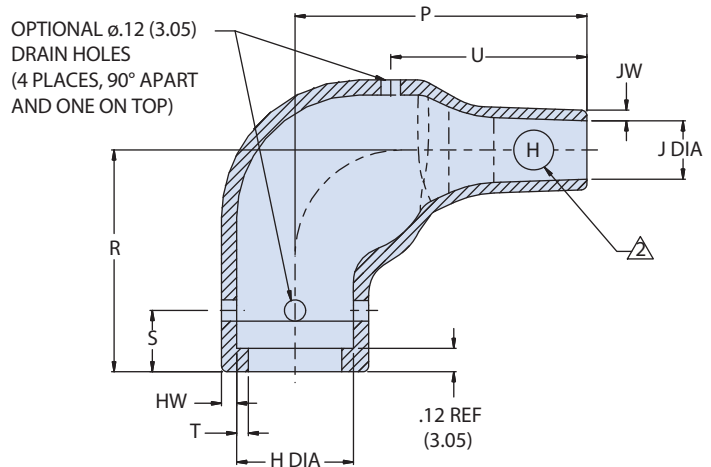

AS RECOVERED WITH DRAIN HOLES

REF: AS85049/141
(FIG. 1- RIGHT ANGLE BOOT)

B

Dimensions														
Dash No See Note 1	H Dia Min*	H Dia Max**	J Dia Min* Material A,B,H	J Dia Min* Material G	J Dia Max**	P** ±10%	R** Ref	T** Ref	HW** ±20%	JW Max**	S** ±10%	U** ±10%	K** ±10%	L** ±10%
01	0.92 (23.4)	0.41 (10.4)	0.92 (23.4)	0.47 (11.9)	0.24 (6.1)	0.84 (21.3)	0.65 (16.5)	0.04 (1.0)	0.05 (1.3)	0.05 (1.3)	0.45 (11.4)	0.47 (11.9)	0.60 (15.2)	0.58 (14.7)
02	1.12 (28.4)	0.61 (15.5)	1.12 (28.4)	0.58 (14.7)	0.26 (6.6)	1.33 (33.8)	0.76 (19.3)	0.04 (1.0)	0.06 (1.5)	0.05 (1.3)	0.47 (11.9)	1.02 (25.9)	0.75 (19.1)	0.98 (24.9)
03	1.22 (31.0)	0.71 (18.0)	1.22 (31.0)	0.63 (16.0)	0.28 (7.1)	1.44 (36.6)	0.83 (21.1)	0.04 (1.0)	0.07 (1.8)	0.07 (1.8)	0.47 (11.9)	1.09 (27.7)	0.75 (19.1)	0.98 (24.9)
04	1.42 (36.1)	0.89 (22.6)	1.42 (36.1)	0.73 (18.5)	0.33 (8.4)	1.72 (43.7)	0.90 (22.9)	0.04 (1.0)	0.07 (1.8)	0.07 (1.8)	0.47 (11.9)	1.16 (29.5)	0.75 (19.1)	1.18 (30.0)
05	1.68 (42.7)	1.12 (28.4)	1.68 (42.7)	0.87 (22.1)	0.39 (9.9)	2.11 (53.6)	1.14 (29.0)	0.07 (1.8)	0.08 (2.0)	0.08 (2.0)	0.47 (11.9)	1.47 (37.3)	0.76 (19.3)	1.30 (33.0)
06	2.04 (51.8)	1.38 (35.1)	2.04 (51.8)	1.39 (35.3)	0.63 (16.0)	3.07 (78.0)	1.32 (33.5)	0.07 (1.8)	0.13 (3.3)	0.13 (3.3)	0.53 (13.5)	2.50 (63.5)	1.00 (25.4)	2.12 (53.8)
07	2.60 (66.0)	1.77 (45.0)	2.60 (66.0)	1.80 (45.7)	0.80 (20.3)	3.84 (97.5)	1.64 (41.7)	0.08 (2.0)	0.15 (3.8)	0.15 (3.8)	0.64 (16.3)	2.75 (69.9)	1.00 (25.4)	2.80 (71.1)
08	3.22 (81.8)	2.40 (61.0)	3.22 (81.8)	2.25 (57.2)	1.00 (25.4)	4.64 (117.9)	2.03 (51.6)	0.08 (2.0)	0.16 (4.1)	0.16 (4.1)	0.64 (16.3)	3.12 (79.2)	1.00 (25.4)	3.15 (80.0)

*As Supplied **As Recovered

Mouser Electronics

Authorized Distributor

Click to View Pricing, Inventory, Delivery & Lifecycle Information:

[Glenair:](#)

[M85049/141-03GC](#) [M85049/141-02BC](#) [M85049/141-04HC](#) [M85049/141-01AC](#) [M85049/141-06AC](#) [M85049/141-01HC](#) [M85049/141-05GC](#) [M85049/141-04GC](#) [M85049/141-03BC](#) [M85049/141-05HC](#) [M85049/141-06GC](#) [M85049/141-05BC](#) [M85049/141-04AC](#) [M85049/141-01GC](#) [M85049/141-01BC](#) [M85049/141-02HC](#) [M85049/141-04BC](#) [M85049/141-03HC](#) [M85049/141-05AC](#) [M85049/141-03AC](#) [M85049/141-06BC](#) [M85049/141-06HC](#) [M85049/141-02AC](#) [M85049/141-02GC](#) [M85049/141-03HU](#) [M85049/141-05HU](#) [M85049/141-01AU](#) [M85049/141-01BU](#) [M85049/141-01GU](#) [M85049/141-01HU](#) [M85049/141-02AU](#) [M85049/141-02BU](#) [M85049/141-06AU](#) [M85049/141-06BU](#) [M85049/141-06GU](#) [M85049/141-06HU](#) [M85049/141-04BU](#) [M85049/141-04GU](#) [M85049/141-04HU](#) [M85049/141-05AU](#) [M85049/141-05BU](#) [M85049/141-05GU](#) [M85049/141-02GU](#) [M85049/141-02HU](#) [M85049/141-03AU](#) [M85049/141-03BU](#) [M85049/141-03GU](#) [M85049/141-04AU](#)