

End Stops

BA (See item 6 on the Accessories drawing.)

End stops are mounted onto the DIN rail at the extremity of the terminal block assembly, giving additional support to the terminal blocks and providing a method for terminal block identification.

- **BAM** DIN 1, DIN 3
- **BADL** Screwless, snaps on DIN 3 rail without a tool.
- **BADH** DIN 3
- **BAEH** DIN 1
- **BADRL** Screwless, snaps on DIN 2 rail without a tool.

Marker-holder for BAM end stop

PEB

Snaps on the upper part of a BAM end stop for easy identification of terminal block assemblies.

- **PEBM**
- **PEBM1**

END STOPS

BAM	P/N	103 002.26
		
Thickness: 9.1 mm .36"	DIN 1, DIN 3 rails	
Multi-rail end stop of grey polyamide equipped with two locking screws.		

[Back to top.](#)

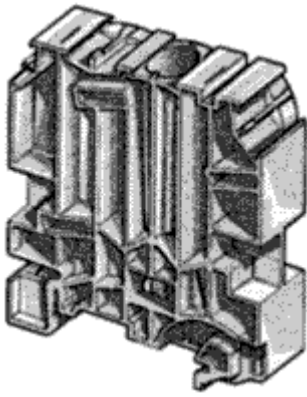
BADH	P/N	116 900.27
		
Thickness: 12 mm .47"	DIN 3 rails	
Tall end stop for use with power blocks, double deck blocks, and electronic interface modules.		

BADL VO	P/N	199 408.02
----------------	------------	-------------------

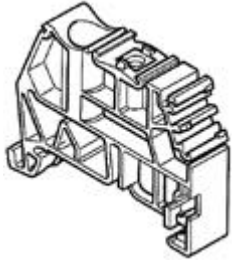

Thickness: 9 mm .35"	DIN 3
Screwless end stop for DIN 3 rail. Snaps on to rail; no tools required.	

[Back to top.](#)

BAEH	P/N	116 934.04
-------------	------------	-------------------

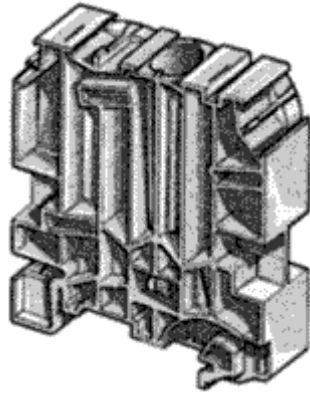

Thickness: 12 mm .47"	DIN 1 rails
Tall end stop for use with power blocks, double deck blocks, and electronic interface modules.	

BADRL	P/N	199 420.21
--------------	------------	-------------------

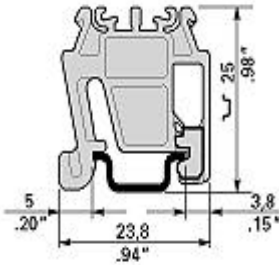

Thickness: 6.5 mm .256"	DIN 2 rail
Screwless end stop for DIN 2 rail. Snaps onto rail; no tool required.	

[Back to top.](#)

MARKER-HOLDERS

PEBM	P/N	113 084.01
-------------	------------	-------------------



Marker-holder with white label for hand marking, and transparent cover.

PEBM1	P/N	113 079.23
--------------	------------	-------------------



Marker-holder with 35 x 17 mm 1.38" x .67" label for white engraving on black background
--