

Jam-nut, rear panel mount receptacle - style 07

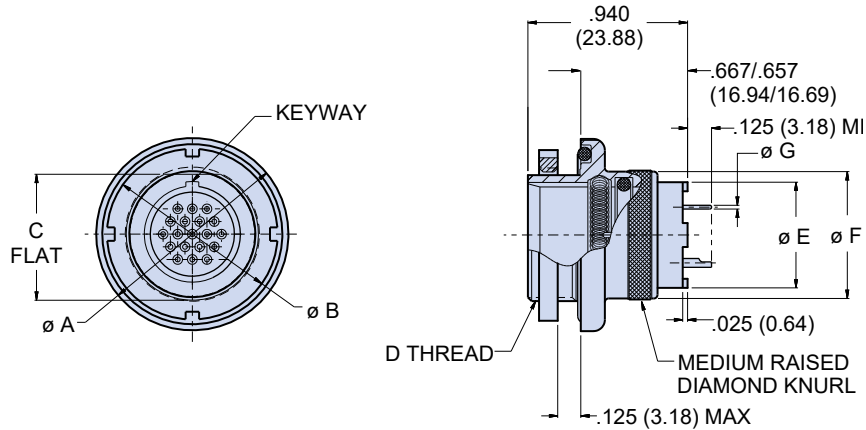

Dimensions							
Shell Size	Ø A	Ø B	C Flat	D Threads	Ø E	Ø F	Ø G Tail Dia.
5	.730 (18.54)	.562 (14.27)	.415 (10.54)	.4375-32 UN-2A	.244 (6.20)	.435 (11.05)	#23 .018/.022 (0.46/0.56)
6	.730 (18.54)	.625 (15.88)	.467 (11.86)	.5000-32 UN-2A	.330 (8.38)	.483 (12.27)	
7	.910 (23.11)	.750 (19.05)	.594 (15.09)	.6250-28 UN-2A	.432 (10.97)	.570 (14.48)	
8	.955 (24.26)	.750 (19.05)	.594 (15.09)	.6250-28 UN-2A	.493 (12.52)	.593 (15.06)	#20 .024/.028 (0.61/0.71)
9	1.000 (25.40)	.812 (20.62)	.655 (16.64)	.6875-28 UN-2A	.551 (14.00)	.685 (17.40)	#16 .060/.064 (1.52/1.63)
10	1.085 (27.56)	.875 (22.23)	.721 (18.31)	.7500-28 UN-2A	.620 (15.75)	.725 (18.42)	
11	1.135 (28.83)	.938 (23.83)	.788 (20.02)	.8125-28 UN-2A	.662 (16.81)	.810 (20.57)	
12	1.190 (30.23)	1.000 (25.40)	.843 (21.41)	.8750-28 UN-2A	.703 (17.86)	.850 (21.59)	#12 .092/.096 (2.34/2.44)
14	1.325 (33.65)	1.125 (28.58)	.968 (24.59)	1.0000-28 UN-2A	.863 (21.92)	.973 (24.71)	

Jam-Nut Rear Panel Mount Cutout Dimensions

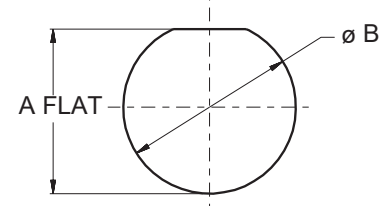

Shell Size	A Flat	Ø B
5	.425 (10.80)	.448 (11.38)
	.421 (10.69)	.443 (11.25)
6	.477 (12.12)	.510 (12.95)
	.473 (12.01)	.505 (12.83)
7	.590 (14.99)	.635 (16.13)
	.586 (14.88)	.630 (16.00)
8	.604 (15.34)	.635 (16.13)
	.600 (15.24)	.630 (16.00)
9	.665 (16.89)	.698 (17.73)
	.661 (16.79)	.693 (17.60)
10	.731 (18.57)	.760 (19.30)
	.727 (18.47)	.755 (19.18)
11	.800 (20.32)	.823 (20.90)
	.796 (20.22)	.880 (22.35)
12	.853 (21.67)	.885 (22.48)
	.849 (21.56)	.880 (22.35)
14	.978 (24.84)	1.010 (25.65)
	.974 (24.74)	1.005 (25.53)

Material and Finish

- Shell, jam-nut: aluminum alloy or CRES / see how to order table
- Insulator: LCP / N.A.
- Interfacial seal, O-ring: fluorosilicone / N.A.
- Contact: copper alloy / gold plate per ASTM B 488, Type II, Code C, Class 1.25, over suitable underplate
- Detent spring: CRES / gold plated
- Potting compound: epoxy / N.A.

Dimensions in Inches (millimeters) are subject to change without notice.

Series 804 Push-Pull Mighty Mouse Connector PC Tail or Solder Cup Receptacle 804-005-00, 804-020-00 Dimensions



Series 804

Jam-nut, front panel mount receptacle - style 00

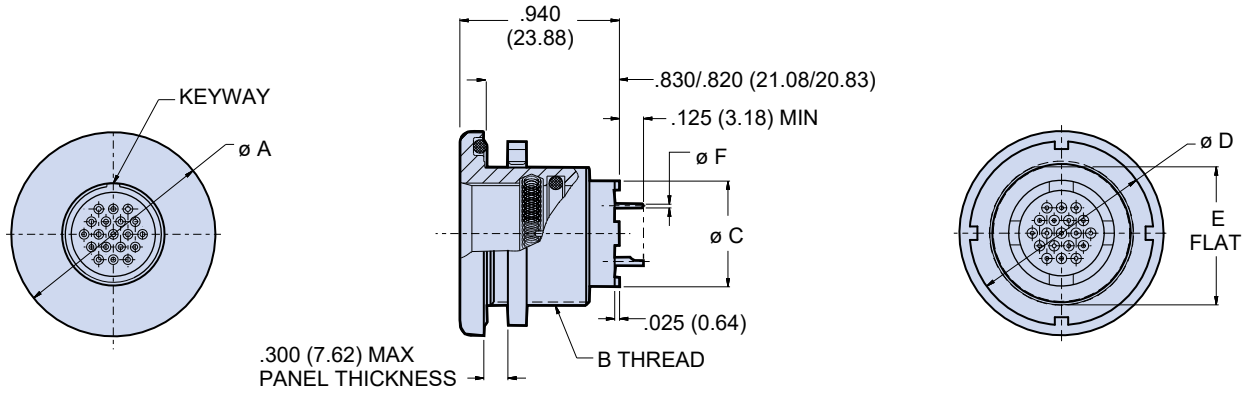

Dimensions						
Shell Size	Ø A	B Threads	Ø C	Ø D	E Flat	Ø F Tail Dia.
5	.830 (21.08)	.5000-32 UN-2A	.244 (6.20)	.625 (15.88)	.470 (11.94)	#23 .018/.022 (0.46/0.56)
6	.885 (22.48)	.5625-28 UN-2A	.330 (8.38)	.688 (17.48)	.530 (13.46)	
7	.995 (25.27)	.6875-28 UN-2A	.432 (10.97)	.812 (20.62)	.663 (16.84)	
8	.995 (25.27)	.6875-28 UN-2A	.493 (12.52)	.812 (20.62)	.663 (16.84)	#20 .024/.028 (0.61/0.71)
9	1.075 (27.30)	.7500-28 UN-2A	.551 (14.00)	.875 (22.23)	.720 (18.29)	#16 .060/.064 (1.52/1.63)
10	1.140 (28.96)	.8125-28 UN-2A	.620 (15.75)	.938 (23.83)	.788 (20.02)	
11	1.190 (30.23)	.8750-28 UN-2A	.662 (16.81)	1.000 (25.40)	.843 (21.41)	
12	1.340 (34.04)	1.0000-28 UN-2A	.703 (17.86)	1.125 (28.58)	.970 (24.64)	#12 .092/.096 (2.34/2.44)
14	1.390 (35.31)	1.0620-20 UN-2A	.863 (21.92)	1.162 (29.51)	1.020 (25.91)	

Jam-Nut, Front Panel Mount Cutout Dimensions		
Shell Size	A Flat	Ø B
5	.482 (12.24) .478 (12.14)	.510 (12.95)
6	.542 (13.77) .538 (13.67)	.575 (14.60)
7	.676 (17.17) .671 (17.04)	.698 (17.73)
8	.676 (17.17) .671 (17.04)	.698 (17.73)
9	.732 (18.59) .728 (18.49)	.760 (19.30)
10	.801 (20.35) .796 (20.22)	.822 (20.88)
11	.855 (21.72) .851 (21.62)	.885 (22.48)
12	.982 (24.94) .978 (24.84)	1.010 (25.65)
14	1.032 (26.21) 1.028 (26.11)	1.075 (27.30)

Material and Finish

- Shell, jam-nut: aluminum alloy or CRES / see how to order table
- Insulator: LCP / N.A.
- Interfacial seal, O-ring: fluorosilicone / N.A.
- Contact: copper alloy / gold plate per ASTM B 488, Type II, Code C, Class 1.25, over suitable underplate
- Detent spring: CRES / gold plated
- Potting compound: epoxy / N.A.

Dimensions in Inches (millimeters) are subject to change without notice.

Mouser Electronics

Authorized Distributor

Click to View Pricing, Inventory, Delivery & Lifecycle Information:

Glenair:

[804-005-00UCR9-19FA](#) [804-02007NF7-10PA](#) [804-02007ZNU6-6SC](#) [804-005-07M10-202SA](#) [804-005-07M12-200SA](#)
[804-005-07M12-201SA](#) [804-005-07M6-23SA](#) [804-005-07M8-200SA](#) [804-005-07M8-28SA](#) [804-005-07M9-200SA](#)
[804-005-07M9-210SA](#) [805-005-07M11-4SA](#) [804-005-07ZNU6-7F](#) [805-005-07NF9-10PC](#) [805-005-07NF9-10PD](#) [805-](#)
[005-07ZNU10-28SA](#) [805-005-07ZNU15-220PA](#) [805-005-07MT15-7PA](#) [805-005-07MT9-10PA](#) [805-005-07MT9-10SA](#)
[805-005-07NF12-202SA](#) [805-005-07NF8-6SA](#) [805-005-07NF8-6SB](#) [804-020-07ZR10-5EA](#) [804-020-07ZR12-37FB](#)
[804-020-07ZR9-4EA](#) [805-005-02NF9-10SA](#) [805-005-02Z19-10PA](#) [805-005-07MT11-19SA](#) [804-020-00NF8-13F](#) [804-](#)
[020-07ZNU10-5EA](#) [804-020-07ZNU12-37FB](#) [804-020-07ZNU6-23FA](#) [804-020-07ZNU7-10F](#) [804-020-07ZNU9-4EA](#)
[804-005-07C9-19PA](#) [804-020-07ZNU5-3PA](#) [804-005-00ZR6-7F](#) [804-005-07C5-3F](#) [804-005-07M10-26FA](#) [804-005-](#)
[00ZR8-28FA](#) [804-020-07NF14-235SA](#) [804-005-07MT10-26SA](#) [804-005-00M10-26EA](#) [804-005-00M10-26S](#) [804-005-](#)
[00M11-31EA](#) [804-005-00M5-3F](#) [804-005-00M6-6PA](#) [804-005-00M6-7FA](#) [804-005-00M7-10EA](#) [804-005-00M8-2E](#)
[804-005-00M8-2F](#) [804-005-00M9-19F](#) [804-005-00MT9-19FA](#) [804-005-00NF10-26S](#) [804-005-00NF14-55S](#) [804-005-](#)
[00NF6-6FA](#) [804-005-00NF6-7S](#) [804-005-00NF7-10FA](#) [804-005-00NF8-13S](#) [804-005-00Z110-201SA](#) [804-005-00ZN6-](#)
[7E](#) [804-005-00ZN6-7F](#) [804-005-00ZNU12-203FA](#) [804-005-00ZNU12-37EA](#) [804-005-00ZNU12-37FB](#) [804-005-](#)
[00ZNU6-23FA](#) [804-005-00ZNU6-6EA](#) [804-005-00ZNU6-6FA](#) [804-005-00ZNU6-6FB](#) [804-005-00ZNU6-7SA](#) [804-005-](#)
[00ZNU9-19FA](#) [804-005-00ZNU9-4EA](#) [804-005-00ZNU9-4F](#) [804-005-07C10-26EB](#) [804-005-07C5-3FA](#) [804-005-07C6-](#)
[6FC](#) [804-005-07C8-13FA](#) [804-005-07C9-19FA](#) [804-005-07M10-26PA](#) [804-005-07M12-202PA](#) [804-005-07M14-](#)
[205SA](#) [804-005-07M5-3PA](#) [804-005-07M6-6FA](#) [804-005-07M6-6SA](#) [804-005-07M6-6SA-489](#) [804-005-07M6-7E](#) [804-](#)
[005-07M6-7EA](#) [804-005-07M8-13SA](#) [804-005-07M8-2P](#) [804-005-07M9-19SA](#) [804-005-07M9-19SA-489](#) [804-005-](#)
[07MT10-26P-856](#) [804-005-07MT10-26S](#) [804-005-07MT10-26SA-856](#) [804-005-07MT6-4PA](#) [804-005-07MT6-6PA](#)
[804-005-07MT6-7E](#) [804-005-07MT6-7EA](#) [804-005-07MT6-7EB](#)