



500mA Single Chip Li-Ion and Li-Polymer Charger

General Description

The LP4068T is a complete constant-current/constant voltage linear charger for single cell lithium-ion battery. No external sense resistor is needed, and no blocking diode is required due to the internal MOSFET architecture. Thermal feedback regulates the charge current to limit the die temperature during high power operation or high ambient temperature. The charge voltage is fixed at 4.2V, and the charge current can be programmed externally by ISET pin with a single resistor.

The LP4068T automatically terminates the charge cycle when the charge current drops to 1/10 setting current value after the final float voltage is reached.

Other features include charge current monitor, under voltage lockout, automatic recharge, status pins and battery temperature detection.

Order Information

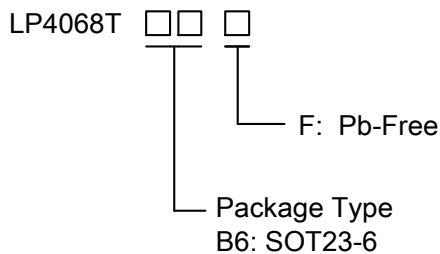

Features

- ◆ Input Voltage up to 28V
- ◆ Input Over Voltage Protection : 7V
- ◆ Short-circuit protection
- ◆ Programmable Charge Current up to 500mA
- ◆ 1µA Battery Reverse Current
- ◆ Over temperature Sensing Protection
- ◆ Protection of Reverse Connection of Battery
- ◆ Constant-Current/Constant-Voltage Operation with Thermal Regulation
- ◆ SOT23-6 Package
- ◆ RoHS Compliant and 100% Lead (Pb)-Free

Applications

- ◇ Portable Media Players/Game
- ◇ Power Bank
- ◇ Bluetooth Applications
- ◇ PDA/MID

Marking Information

Device	Marking	Package	Shipping
LP4068TB6F	LP4068 TYWX	SOT23-6	3K/REEL
Marking indication: Y:Production year W:Production week X: Series Number			



Functional Pin Description

Package Type	Pin Configurations
SOT23-6	<p style="text-align: center;">SOT23-6 (Top View)</p>

Pin Description

No.	NAME	DESCRIPTION
1	TS	Temperature Senses Voltage Input. This pin senses the temperature of the battery pack and stops the charger when the temperature is out of range. Connect to GND for disabling this function.
2	GND	Ground.
3	IN	Input Power Source.
4	BAT	Charge Current Output. Typically a 10μF Tantalum capacitor is needed for stability when there is no battery attached. When a battery is attached, only a 1uF ceramic capacitor is required.
5	CHRG	Open-Drain Charge Status Output. When the battery is charging, the CHRG pin is pulled low by an internal N-MOS. When the charge cycle is completed, the pin could be pulled High by an external pull high resistor.
6	ISET	Charge Current Program. The charge current is programmed by connecting a 1% resistor (R_{ISET}) to ground. $I_{BAT} = \frac{1700 \times V_{ISET}}{R_{ISET}}$



Typical Application Circuit

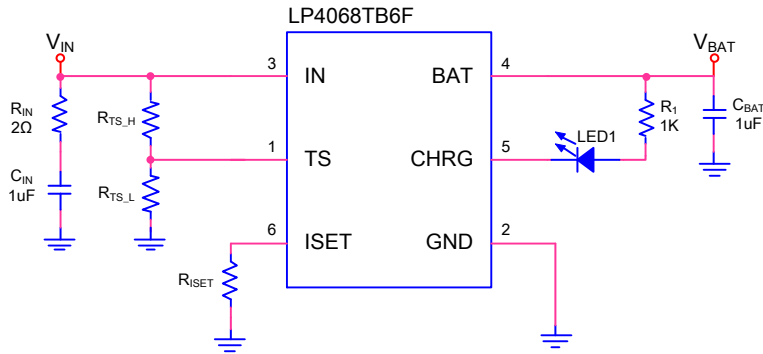

Functional Block Diagram

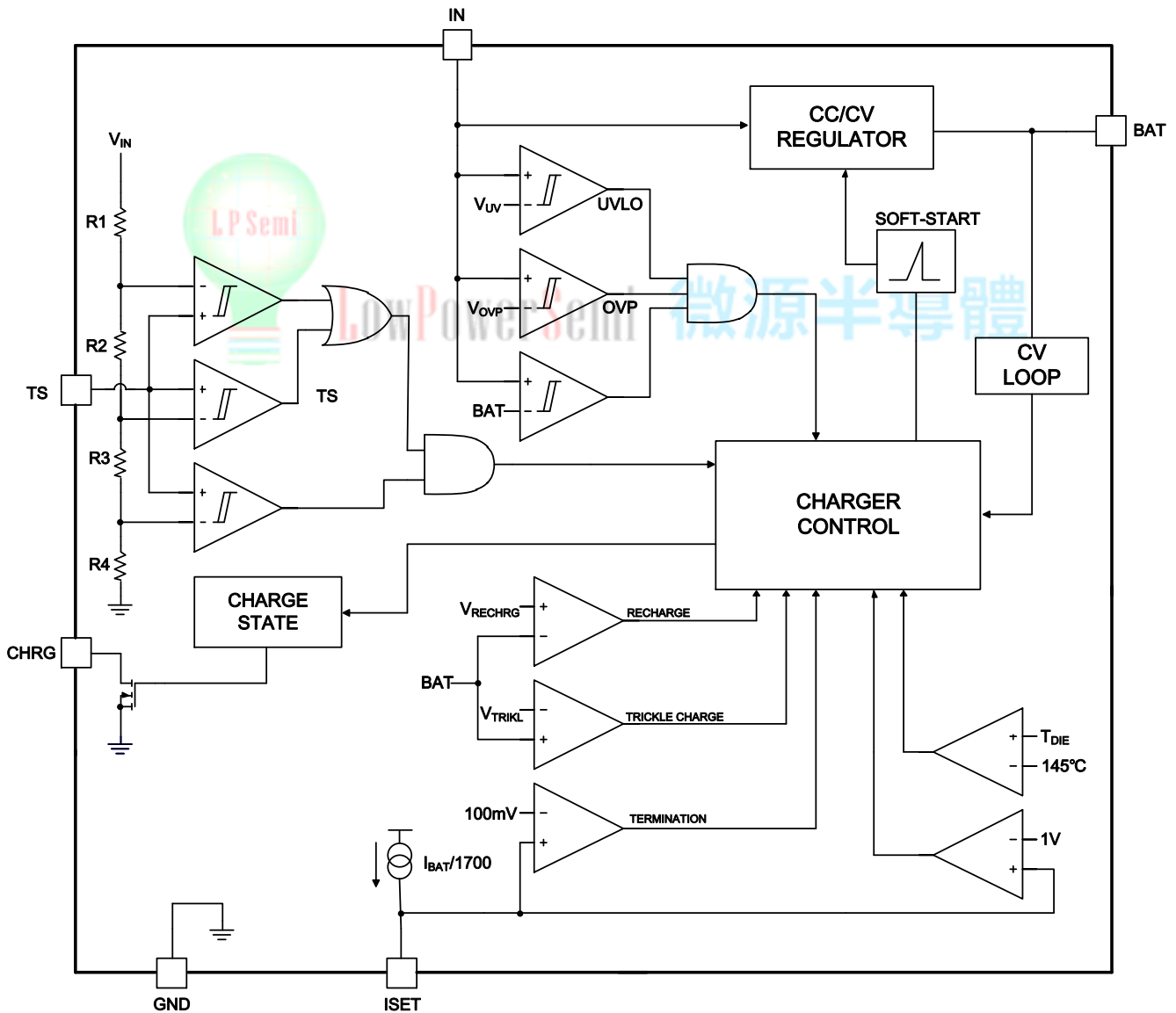



Absolute Maximum Ratings ^{Note 1}

✧ Input Voltage to GND	-0.3V to 28V
✧ BAT Voltage GND	- 5V to 15V
✧ Other pin to GND	-0.3V to 6.5V
✧ Maximum Junction Temperature(T_J)	150°C
✧ Maximum Soldering Temperature (at leads, 10 sec)	260°C
✧ Operating Junction Temperature Range	-20°C to 85°C
✧ Storage Temperature	-65°C to 165°C

Thermal Information

✧ Maximum Power Dissipation ($P_D, T_A=25^\circ\text{C}$)	0.6W
✧ Thermal Resistance (θ_{JA})	200°C/W

ESD Susceptibility

✧ HBM(Human Body Model)	2KV
✧ MM(Machine Model)	200V

Note 1. Stresses beyond those listed under “Absolute Maximum Ratings” may cause permanent damage to the device. These are stress ratings only, and functional operation of the device at these or any other conditions beyond those indicated in the operational sections of the specifications is not implied. Exposure to absolute maximum rating conditions for extended periods may affect device reliability.

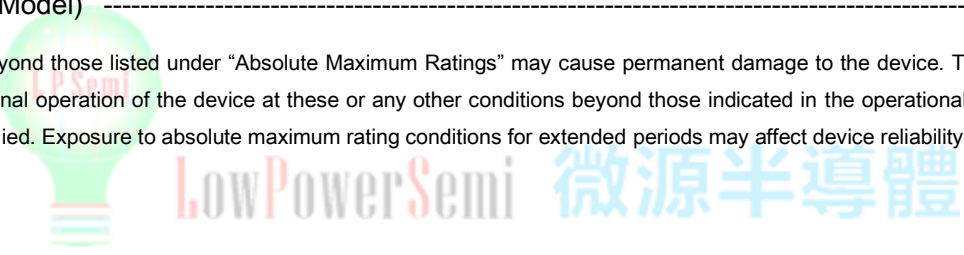



Electrical Characteristics

($T_A=25^{\circ}\text{C}$, $V_{IN}=5\text{V}$, unless otherwise noted.)

SYMBOL	PARAMETER	CONDITIONS	MIN	TYP.	MAX	UNITS
V_{IN}	Input Voltage		4.5	5	6.5	V
I_{IN}	Input Supply Current	$R_{ISET}=17\text{K}$, Charge Mode		300		μA
		$V_{BAT}=4.2\text{V}$, Charge Terminated		160		μA
		$R_{ISET}=\text{NC}$, Shutdown Mode		200		μA
V_{FLOAT}	Regulated Output (Float) Voltage	$I_{BAT}=40\text{mA}$,	4.158	4.2	4.242	V
V_{UV}	V_{IN} Under Voltage Lockout Threshold	From V_{IN} Low to High		3.5		V
V_{UV_HYS}	Under Voltage Lockout Hysteresis			110		mV
V_{OVP}	Input Voltage OVP	V_{IN} Rising		7		V
V_{OVP_HYS}	OVP Hysteresis			150		mV
I_{BAT}	BAT Pin Current	$R_{ISET}=3.4\text{k}$, Current Mode		500		mA
		$R_{ISET}=17\text{k}$, Current Mode		100		mA
		$V_{BAT}=4.2\text{V}$ ($V_{IN}=\text{float}$ or 0V)		1		μA
I_{TRIKL}	Trickle Charge Current	$V_{BAT}<V_{TRIKL}$, $R_{ISET}=10\text{k}$, Charge Mode		10		$\%I_{BAT}$
V_{TRIKL}	Trickle Charge Threshold Voltage	V_{BAT} Rising		2.6		V
V_{TRIKL_HYS}	Trickle Charge Hysteresis Voltage			150		mV
I_{TERM}	Termination Current Threshold			10		$\%I_{BAT}$
V_{ISET}	ISET Pin Voltage	$R_{ISET}=10\text{k}$, Current Mode		1		V
I_{CHRG}	CHRG Pin Sink Current	$V_{CHRG}=5\text{V}$			1	μA
V_{CHRG}	CHRG Pin Output Low Voltage	$I_{CHRG}=5\text{mA}$			0.5	V
ΔV_{RECHRG}	Recharge Battery Threshold Voltage	$V_{FLOAT}-V_{RECHRG}$		150		mV
V_{ASD}	$V_{IN} - V_{BAT}$ Lockout Threshold Voltage	$V_{BAT}=3.5\text{V}$, V_{IN} Rising		150		mV
V_{NTC_H}	Threshold Voltage of VNTC rising			60		$\%V_{IN}$
V_{NTC_L}	Threshold Voltage of VNTC falling			30		$\%V_{IN}$
V_{NTC_HYS}	NTC Hysteresis Voltage			90		mV
T_{LIM}	Junction Temperature in Constant Temperature Mode			145		$^{\circ}\text{C}$



Typical Charging Profile

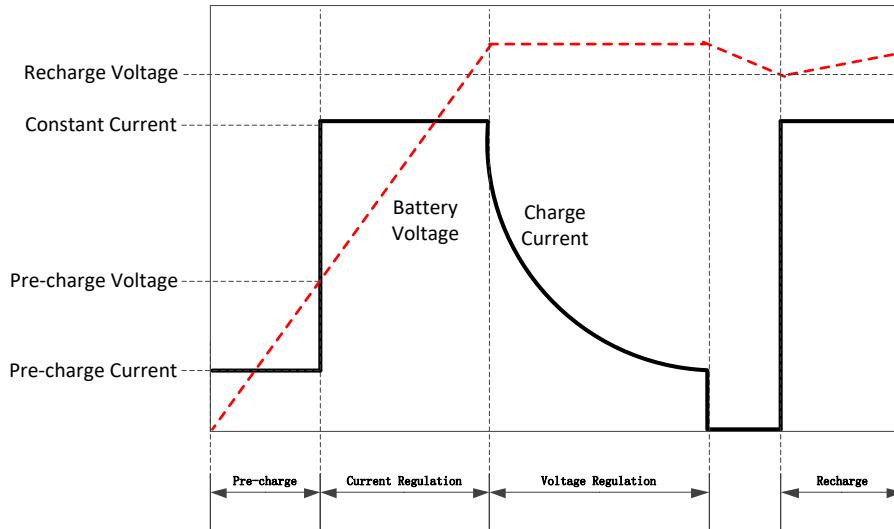

Typical Performance Characteristics

(C_{IN}=C_{OUT}=10uF, R_{ISSET}=16.5K, unless otherwise noted)

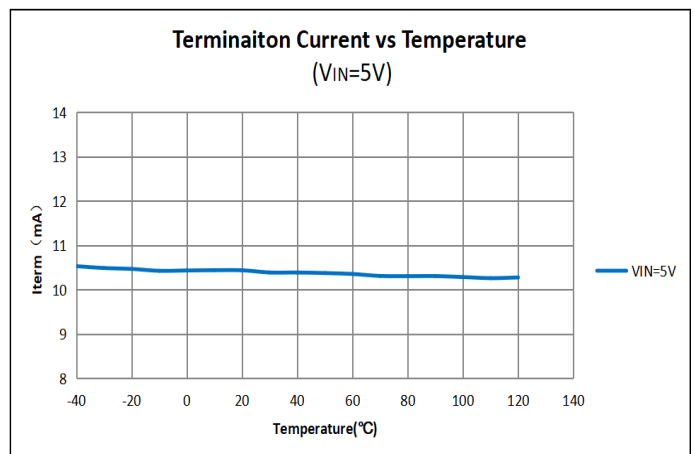
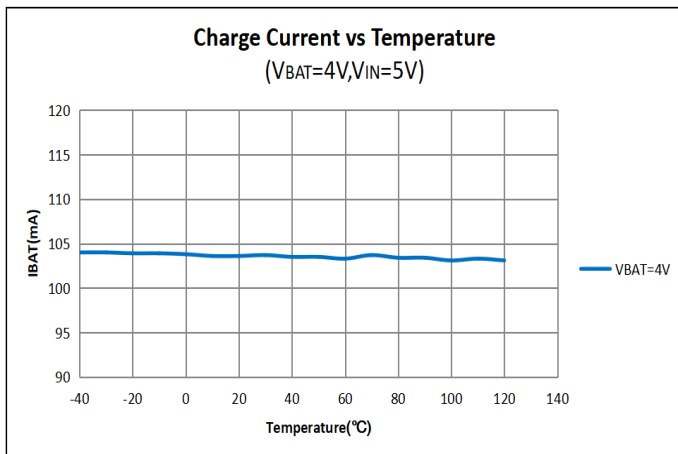
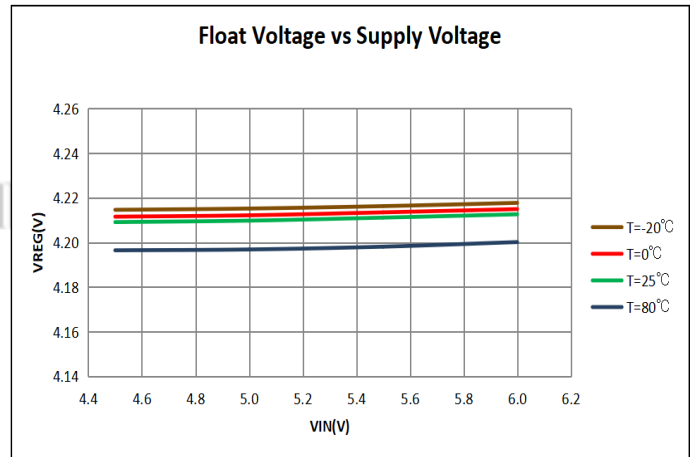
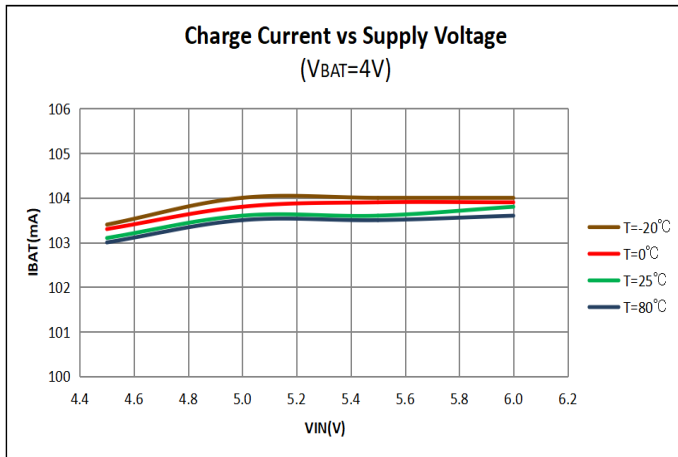



Application Performance Curves

($C_{IN}=C_{OUT}=10\mu F$, $R_{ISET}=16.5K$, unless otherwise noted)

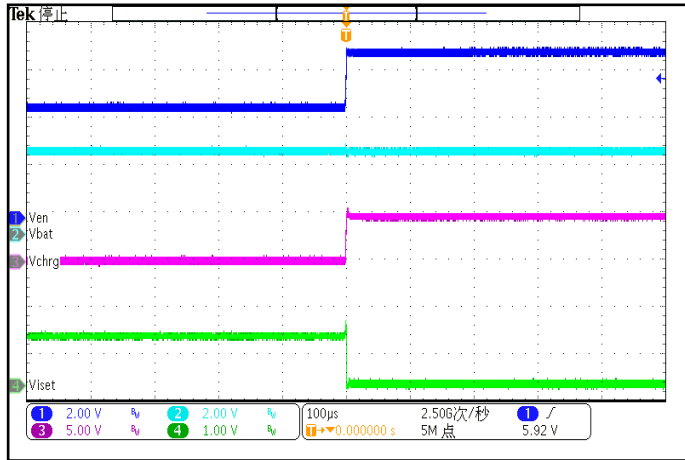

$V_{BAT}=3.5V$, $V_{IN}=5V \rightarrow 7V$

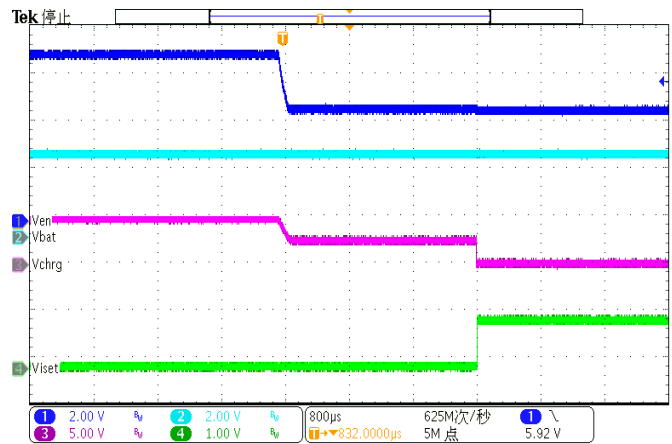

$V_{BAT}=3.5V$, $V_{IN}=7V \rightarrow 5V$





Application Information

The LP4068T has built-in input voltage surge protection as high as +28V. The charger IC will be automatically disabled when the input voltage is higher than 7V. A charge cycle begins when EN is high, the voltage at the IN pin rises above the UVLO threshold level and a program resistor is connected from the ISET pin to ground. If the BAT pin is less than 2.6V, the charger enters trickle charge mode. In this mode, the LP4068T supplies approximately 1/10 the ISET programmed charge current to bring the battery voltage up to a safe level for full current charging. When the BAT pin voltage rises above 2.6V, the charger enters constant-current mode(CC), where the ISET programmed charge current is supplied to the battery. When the Battery Voltage approaches the final float voltage, It enters constant-voltage mode(CV) and the charge current begins to decrease, and the battery full indication is set when the charge current in the CV mode is reduced to the programmed full battery current (1/10).

Charge Termination

A charge cycle is terminated when the charge current falls to 1/10th the ISET programmed value after the final float voltage is reached. This condition is detected by using an internal, filtered comparator to monitor the ISET pin. When the ISET pin voltage falls below 100mV for longer than t_{TERM} (typically 1ms), charging is terminated.

Charge Current Program

The charge current (I_{BAT}) is set by a resistor (R_{ISET}) connecting from the ISET pin to GND. The relationship of the charge current and the programming resistance is established by the following equations (V_{ISET}=1V).

$$I_{BAT} = \frac{1700 \times V_{ISET}}{R_{ISET}}$$

Automatic Recharge

Once the charge cycle is terminated, the LP4068T continuously monitors the voltage on the BAT pin. A charge cycle restarts when the battery voltage falls below 4.05V (which corresponds to approximately 80% to 90% battery capacity). This ensures that the battery is kept at or near a fully charged condition and eliminates the need for periodic charge cycle initiations.

Charge Status Indicator (CHRG)

After application of a 5V source, the input voltage rises above the UVLO and sleep thresholds (V_{IN}>V_{BAT}+V_{ASD}), but is less than OVP (V_{IN}<V_{OVP}), CHRG has two different states: strong pull-down (~5mA) and high impedance. The strong pull-down state indicates that the LP4068T is in a charge cycle. When the charger is entered CV mode and once the charge current has reduced to the battery full charge current threshold (I_{TERM}), the CHRG pin will become high impedance.

Function	CHRG
Charging	Low
Charge Finish	Hi-Z

Thermal Limit

An internal thermal feedback loop reduces charge current if junction temperature attempts to rise above a preset value of approximately 145°C. This feature protects the device from excessive temperature and allows the user to push the limits of the power handling capability of a given circuit board without risk of damaging the device. The charge current can be set according to typical (not worst-case) ambient temperature with the assurance that the charger will automatically reduce the current in worst-case conditions.



Packaging Information

SOT23-6

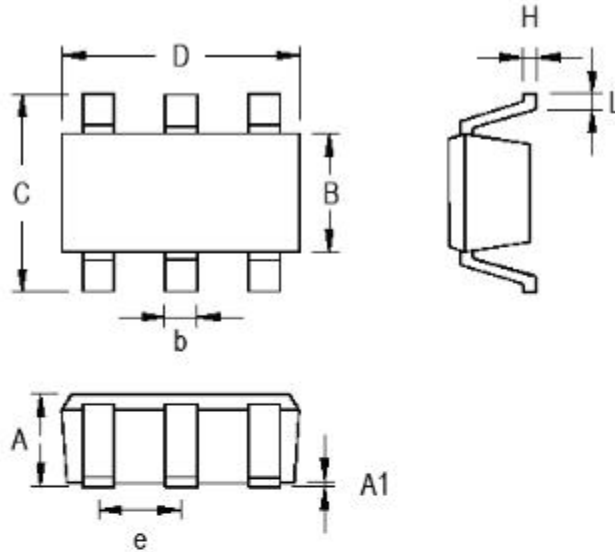

Symbol	Dimensions In Millimeters		Dimensions In Inches	
	Min	Max	Min	Max
A	0.889	1.295	0.031	0.051
A1	0.000	0.152	0.000	0.006
B	1.397	1.803	0.055	0.071
b	0.250	0.560	0.010	0.022
C	2.591	2.997	0.102	0.118
D	2.692	3.099	0.106	0.122
e	0.838	1.041	0.033	0.041
H	0.080	0.254	0.003	0.010
L	0.300	0.610	0.012	0.024