

REVISIONS					
P	LTR	DESCRIPTION	DATE	DWN	APVD
1		NEW DRAWING	06JUN2023	LP	MY

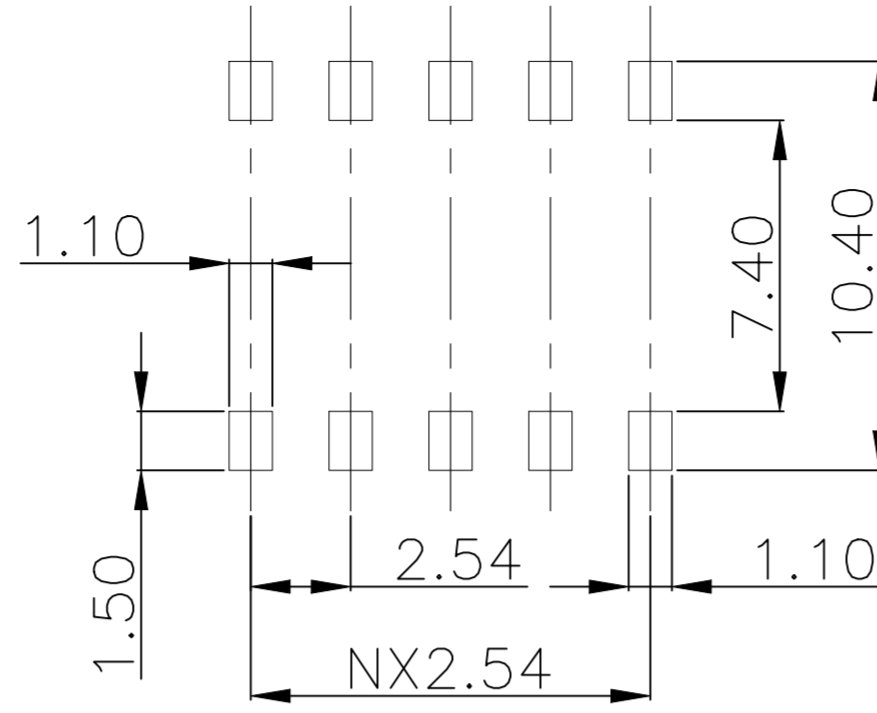

P.C.B HOLE DIMENSION

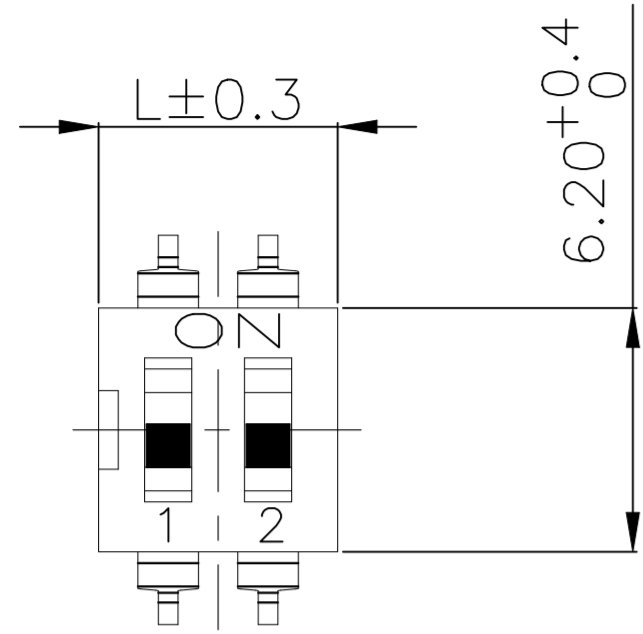
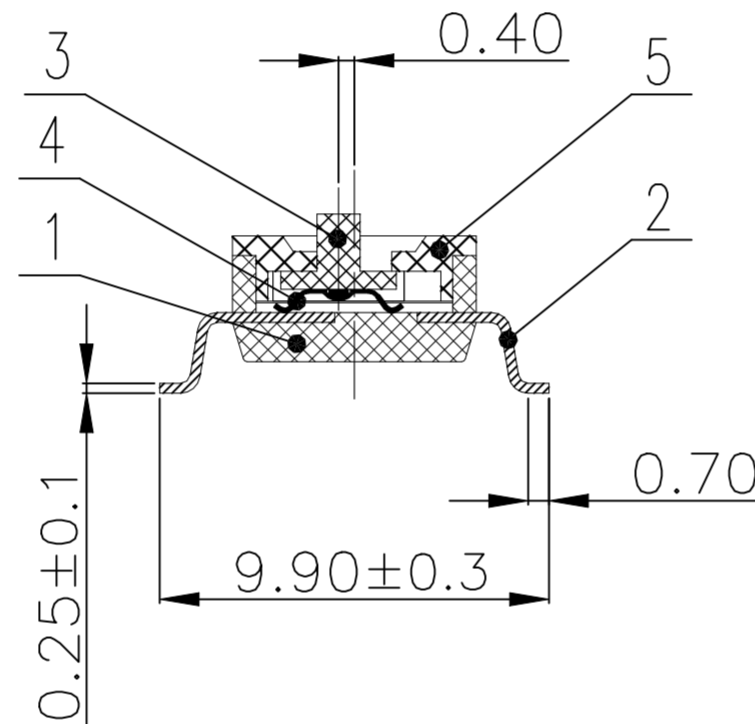
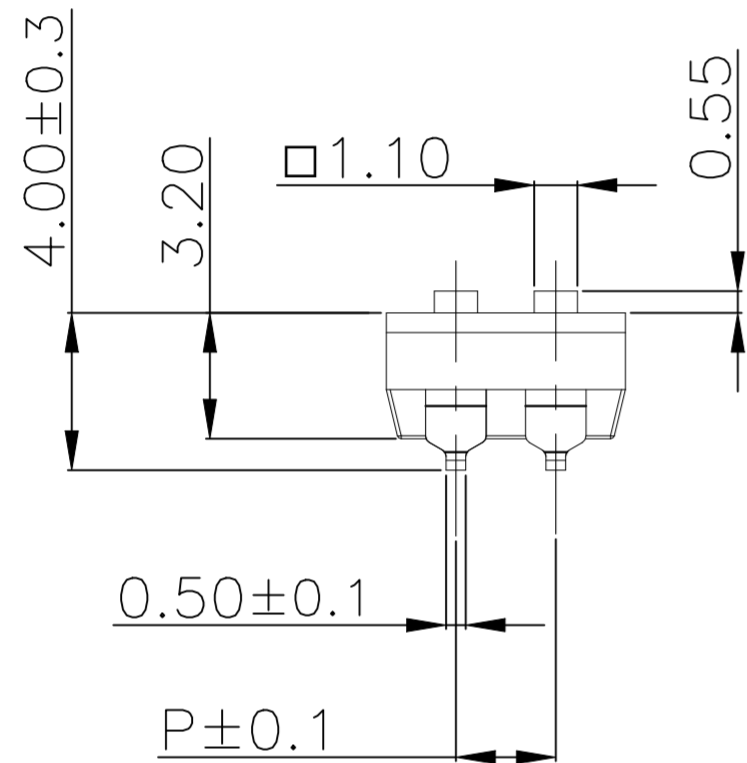

SPECIFICATION

- Rating :
  - Switching : 25mA,24VDC
  - Non-Switching : 100mA,50VDC
- Contact Resistance :
  - Initial 50mΩ Max
  - After Life Test 150mΩ Max
- Insulation Resistance : 100MΩ Min/500 VDC
- Withstand Voltage: 500VAC for 1 minute
- Operating Force : 1Kgf Max
- Stroke : 0.9mm
- Mechanical Life : 1,000 Cycles
- Electrical Life : Min 1,000 Cycles/25mA,24VDC
- Operating Temperature guarantee range :
  - 40°C~+85°C
- Storage Temperature : -40°C~+85°C
- Soldering Information :
  - Reflow Soldering : 260°C, 10sec Max (Peak Temperature)
  - Manual Soldering : 30W iron, 320±5°C, 3sec Max
  - Keep in "OFF" Position During Soldering

NOTE

- Switches to be Received In The "OFF" Position and Packaged In Clear Tubes to Accommodate Auto Insertion
- Top Surface to be Clearly Marked as Shown
- All raw materials must comply with RoHS

AUTOMOTIVE STANDARD MANAGEMENT TOLERANCE

DIMENSION	0 to 3	3 to 6	6 to 30	30to120	120to400	Angular tolerance unless otherwise specified : ±2'
TORERANCE	±0.15	±0.2	±0.25	±0.3	±0.5	

Model No. Explanation  
ADE N XX S XX 04

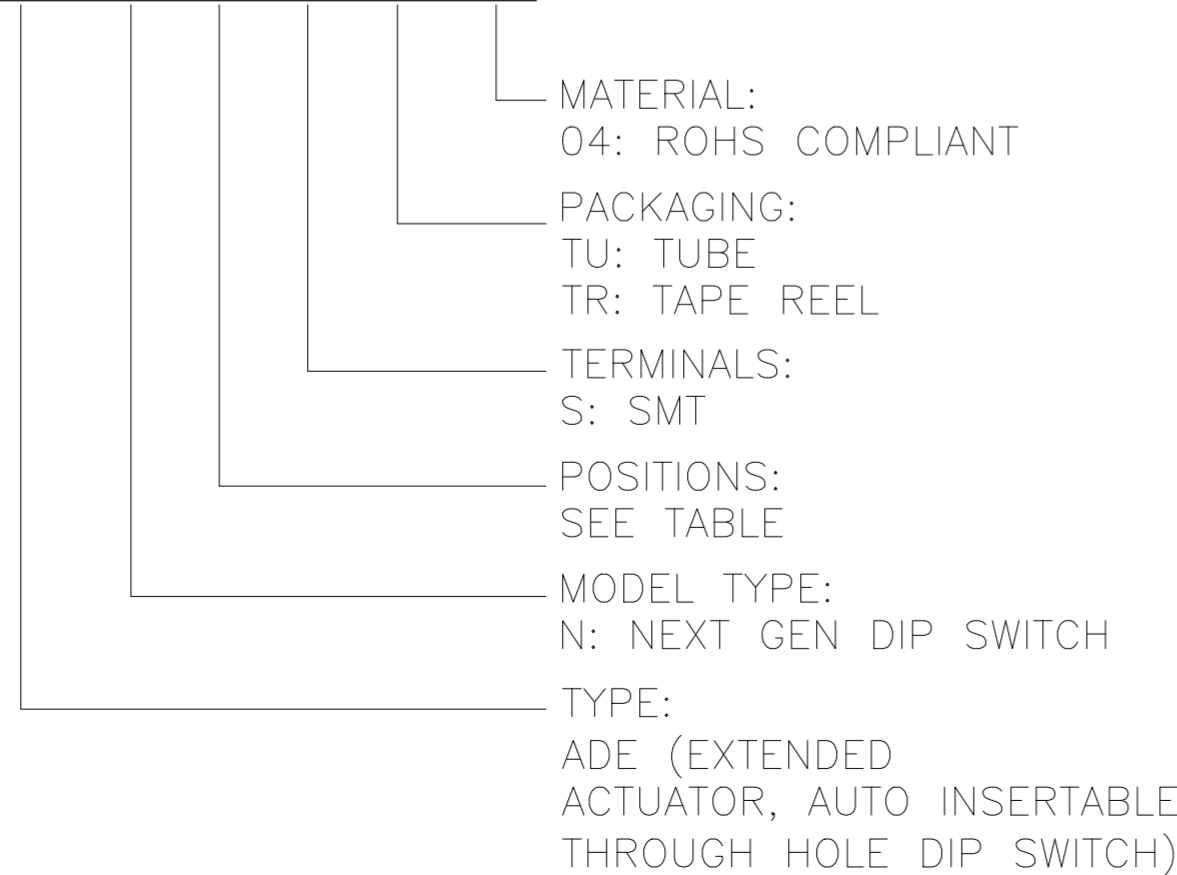

5	COVER	-	PA9T	UL94V-0
4	CONTACT	-	BERYLLIUM COPPER	PLATE : GOLD FLASH/NICKEL
3	ACTUATOR	-	PA46	UL94V-0
2	TERMINAL	-	PHOSPHOR BRONZE	PLATE : GOLD FLASH/NICKEL
1	T/CASE	-	PA9T	UL94V-0
NO.	PART NAME	PART(CODE) NO	MATERIAL	NOTE

3	ADE NEXT GEN. 02 POS. SMT TR	2P	6.08	2.54	ADEN02STR04	2454985-3
2	ADE NEXT GEN. 2 POS. SMT TU	2P	6.08	2.54	ADEN02STU04	2454985-2
1	ADE NEXT GEN. 10 POS. SMT TU	10P	26.40	22.86	ADEN10STU04	2454985-1
SL NO.	DESCRIPTION	POSITION	DIM "L" (mm)	DIM "P" (mm)	TE SMART PN	TE PN

THIS DRAWING IS A CONTROLLED DOCUMENT.

DWN: LINGANATHAN P 26MAY2023  
CHK: MANOJ. YADAV 26MAY2023  
APVD: MANOJ. YADAV 26MAY2023

**TE** TE Connectivity

NAME: ADE NEXT GEN, 2 POS. SMT TU

SIZE: A2 CAGE CODE: 00779 DRAWING NO: C=2454985 RESTRICTED TO: -

SCALE: 1:1 SHEET: 1 of 2 REV: 1

CUSTOMER DRAWING

# TAPE & REEL PACKAGING DETAILS

REVISIONS					
P	LTR	DESCRIPTION	DATE	DWN	APVD
-	-	SEE SHEET 1	-	-	-

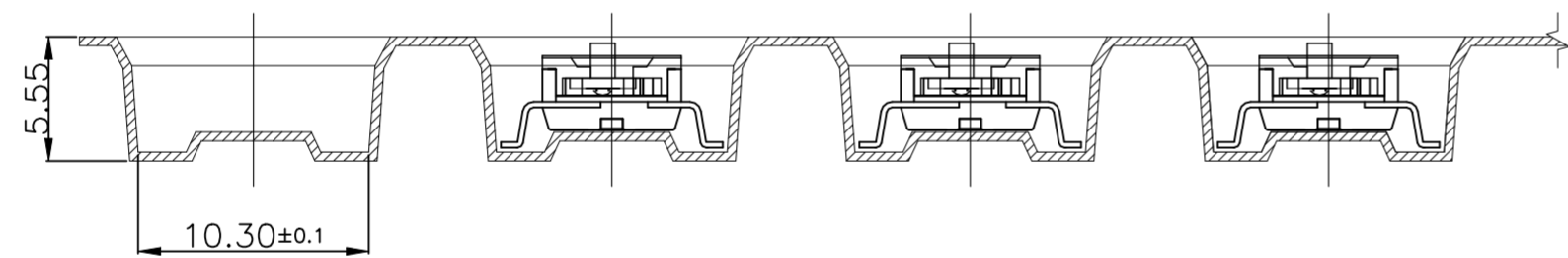
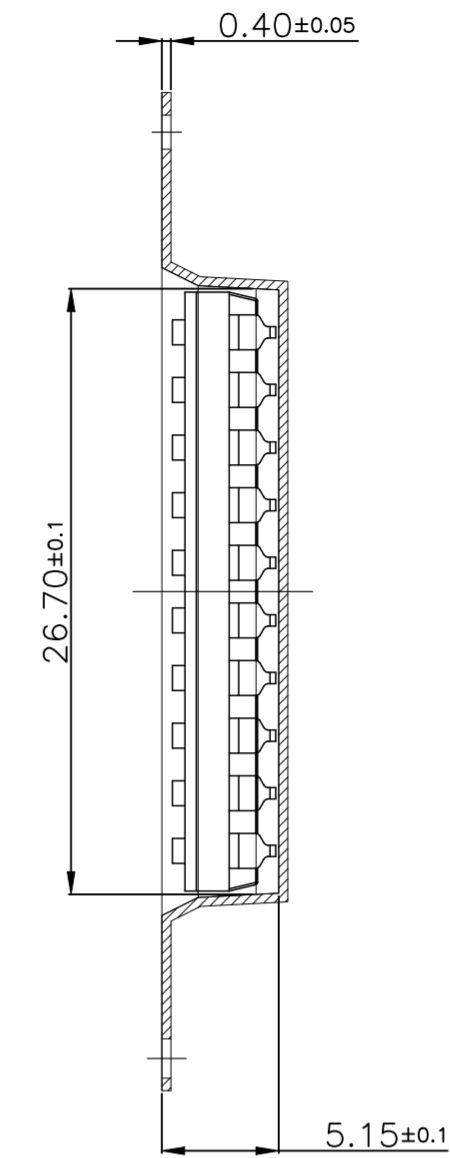
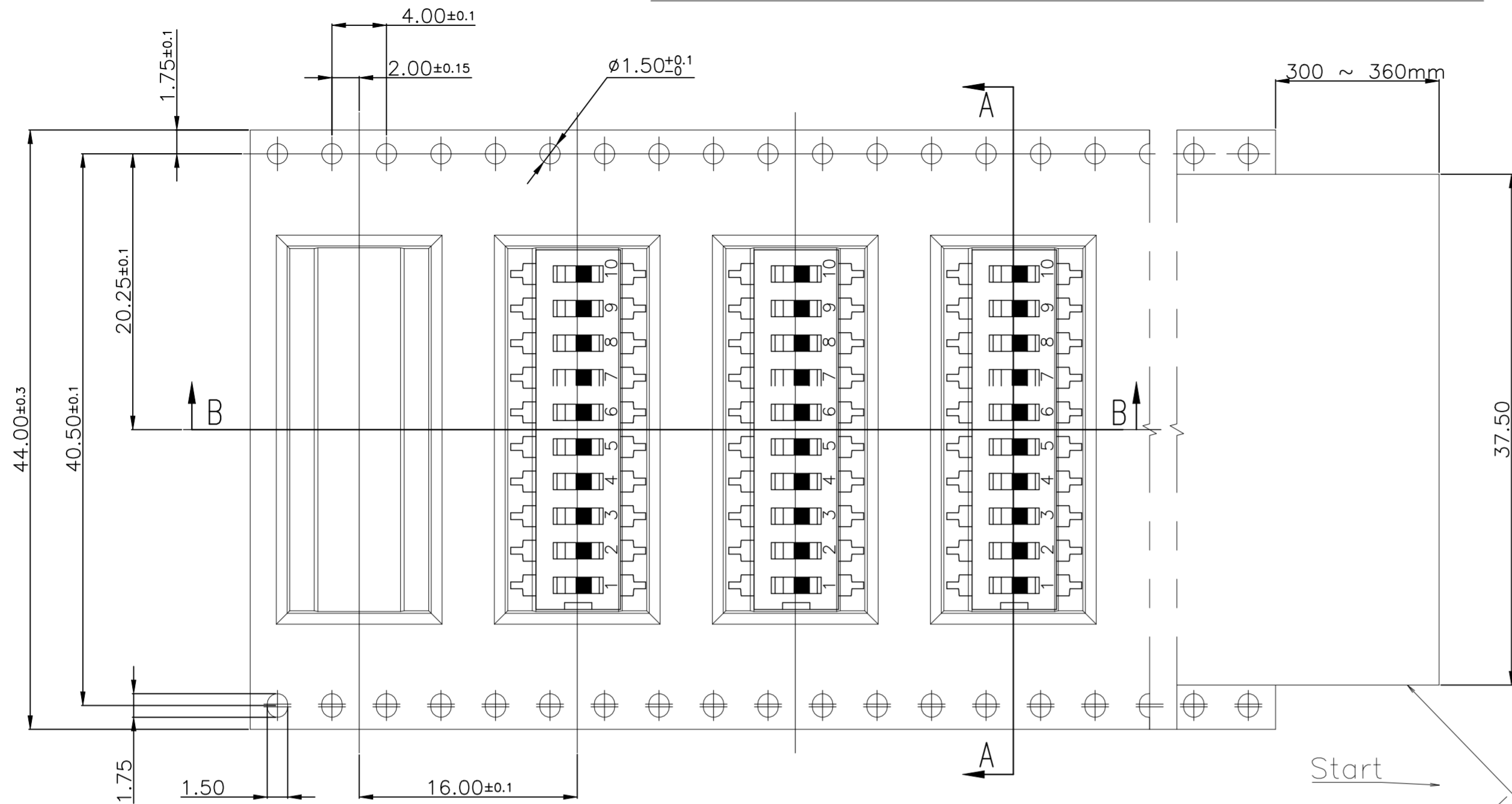

SECTION B-B

Cover tape

SECTION A-A

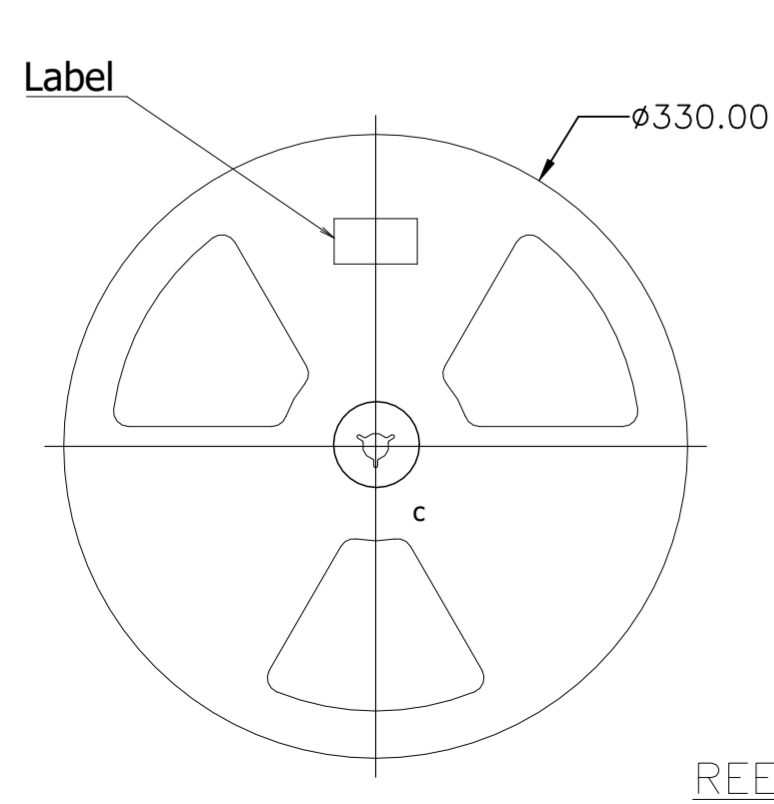

REEL

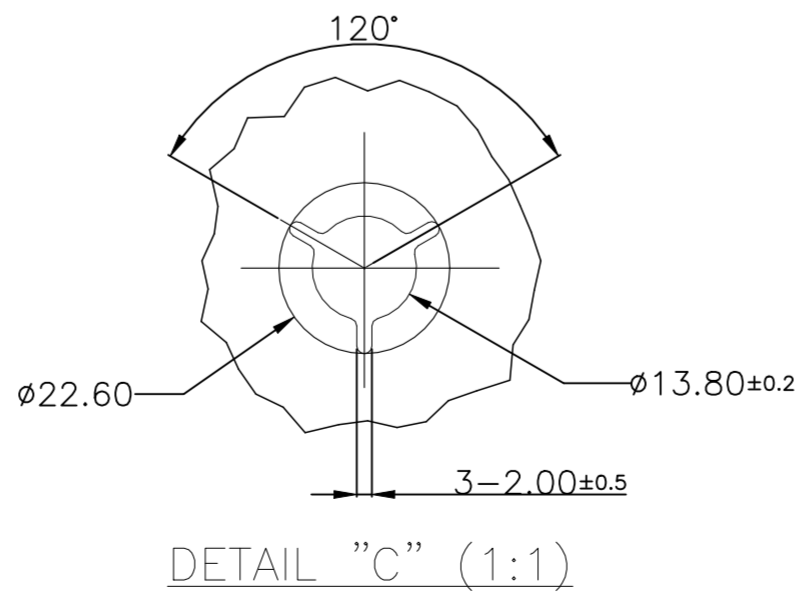
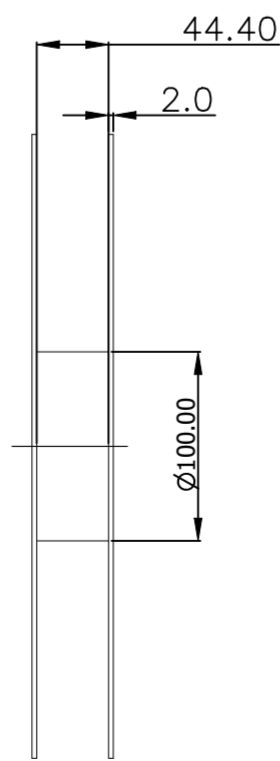

DETAIL "C" (1:1)

Packing Specification		
Non-Pocket Portion	Trailer Portion	200mm [20 pocket min]
	Leader Portion	20 pocket min
S/W Packing Q'TY		800 pcs

THIS DRAWING IS A CONTROLLED DOCUMENT.		DWN LINGANATHAN P 26MAY2023	<b>TE</b> TE Connectivity	
DIMENSIONS: mm		CHK MANOJ. YADAV 26MAY2023		
TOLERANCES UNLESS OTHERWISE SPECIFIED:		APVD MANOJ. YADAV 26MAY2023	NAME ADE NEXT GEN, 2 POS. SMT TU	
0 PLC ± -	1 PLC ± -	PRODUCT SPEC -	APPLICATION SPEC -	
2 PLC ± -	3 PLC ± -	WEIGHT -	SIZE A2	CAGE CODE 00779
4 PLC ± -	ANGLES ± -	CUSTOMER DRAWING	DRAWING NO C=2454985	RESTRICTED TO -
FINISH -		SCALE 1:1	SHEET 2 OF 2	REV 1