



Octal, 2-Wire Serial 8-Bit DAC with Rail-to-Rail Outputs

MAX521

General Description

The MAX521 is an octal, 8-bit voltage-output digital-to-analog converter (DAC) with a simple 2-wire serial interface that allows communication between multiple devices. It operates from a single 5V supply and its internal precision buffers allow the DAC outputs to swing rail-to-rail. The reference input range includes both supply rails.

The MAX521 has five reference inputs. The first four DACs (DAC0–DAC3) each have a separate reference input (REF0–REF3), allowing each DAC's full-scale range to be set independently. The remaining four DACs (DAC4–DAC7) share the remaining reference input, REF4.

The MAX521 features a serial interface and internal software protocol, allowing communication at data rates up to 400kbps. The interface, combined with the double-buffered input configuration, allows the DAC registers to be updated individually or simultaneously. In addition, the device can be put into a low-power shutdown mode that reduces supply current to 4µA. Power-on reset ensures the DAC outputs are at 0V when power is initially applied.

The MAX521 is available in 20-pin DIP and 24-pin SO package as well as a space-saving 24-pin SSOP package.

Applications

- Minimum Component Analog Systems
- Digital Offset/Gain Adjustment
- Industrial Process Control
- Automatic Test Equipment
- Programmable Attenuators

Pin Configurations

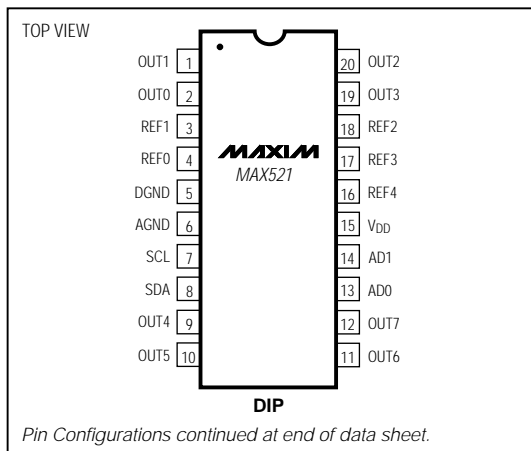

Features

- ◆ Single +5V Supply
- ◆ Simple 2-Wire Serial Interface
- ◆ I²C Compatible
- ◆ Output Buffer Amplifiers Swing Rail-to-Rail
- ◆ Reference Input Range Includes Both Supply Rails
- ◆ Power-On Reset Clears All Latches
- ◆ 4µA Power-Down Mode

Ordering Information

PART	TEMP. RANGE	PIN-PACKAGE	TUE (LSB)
MAX521ACPP	0°C to +70°C	20 Plastic DIP	1
MAX521BCPP	0°C to +70°C	20 Plastic DIP	2
MAX521ACWG	0°C to +70°C	24 Wide SO	1
MAX521BCWG	0°C to +70°C	24 Wide SO	2
MAX521ACAG	0°C to +70°C	24 SSOP	1
MAX521BCAG	0°C to +70°C	24 SSOP	2
MAX521BC/D	0°C to +70°C	Dice*	2

Ordering Information continued at end of data sheet.

*Dice are specified at T_A = +25°C, DC parameters only.

Functional Diagram

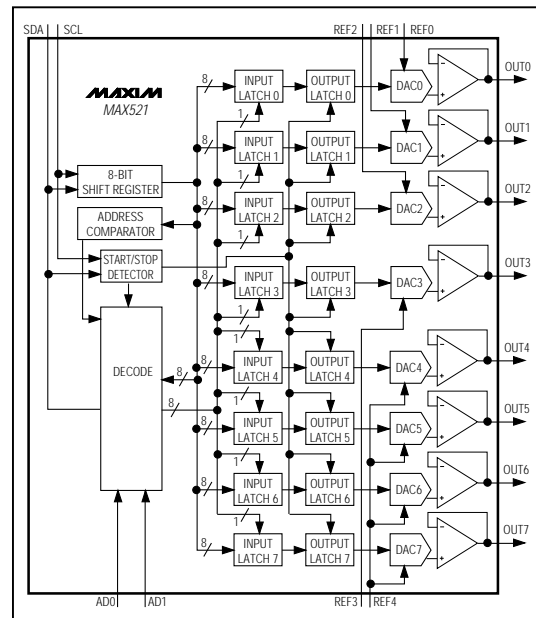

Octal, 2-Wire Serial 8-Bit DAC with Rail-to-Rail Outputs

ABSOLUTE MAXIMUM RATINGS

V _{DD} to DGND	-0.3V to +6V	24-Pin Wide SO (derate 11.76mW/°C above +70°C)	941mW
V _{DD} to AGND	-0.3V to +6V	24-Pin SSOP (derate 8.00mW/°C above +70°C)	640mW
OUT ₀ -OUT ₇	-0.3V to (V _{DD} + 0.3V)	20-Pin CERDIP (derate 11.11mW/°C above +70°C)	889mW
REF ₀ -REF ₄	-0.3V to (V _{DD} + 0.3V)	Operating Temperature Ranges	
AD ₀ , AD ₁	-0.3V to (V _{DD} + 0.3V)	MAX521_C_ _	0°C to +70°C
SCL, SDA to DGND	-0.3V to +6V	MAX521_E_ _	-40°C to +85°C
AGND to DGND	-0.3V to +0.3V	MAX521BMJP	-55°C to +125°C
Maximum Current into Any Pin	50mA	Storage Temperature Range	
Continuous Power Dissipation (T _A = +70°C)		-65°C to +150°C	
20-Pin Plastic DIP (derate 11.11mW/°C above +70°C)	889mW	Lead Temperature (soldering, 10sec)	
		+300°C	

Stresses beyond those listed under "Absolute Maximum Ratings" may cause permanent damage to the device. These are stress ratings only, and functional operation of the device at these or any other conditions beyond those indicated in the operational sections of the specifications is not implied. Exposure to absolute maximum rating conditions for extended periods may affect device reliability.

ELECTRICAL CHARACTERISTICS

(V_{DD} = 5V ±10%, V_{REF_} = 4V, R_L = 10kΩ, C_L = 100pF, T_A = T_{MIN} to T_{MAX}, unless otherwise noted. Typical values are T_A = +25°C.)

PARAMETER	SYMBOL	CONDITIONS	MIN	TYP	MAX	UNITS	
STATIC ACCURACY							
Resolution			8			Bits	
Total Unadjusted Error	TUE	MAX521A			±1.5	LSB	
		MAX521B			±2.0		
Differential Nonlinearity	DNL	Guaranteed monotonic			±1.0	LSB	
Zero-Code-Error	ZCE	Code = 00 hex	MAX521_C			18	mV
			MAX521_E			20	
			MAX521BM			20	
Zero-Code-Error Supply Rejection		Code = 00 hex	MAX521_C			±1	mV
			MAX521_E			±1	
			MAX521BM			±1	
Zero-Code-Error Temperature Coefficient		Code = 00 hex			±10	μV/°C	
Full-Scale Error		Code = FF hex	MAX521_C			18	mV
			MAX521_E			20	
			MAX521BM			20	
Full-Scale-Error Supply Rejection		Code = FF hex V _{DD} = 5V ±10%	MAX521_C			±1	mV
			MAX521_E			±1	
			MAX521BM			±1	
Full-Scale-Error Temperature Coefficient					±10	μV/°C	
REFERENCE INPUTS							
Input Voltage Range			0	V _{DD}		V	
Input Resistance	R _{IN}	Code = 55 hex (Note 1)	REF ₄	4	6	kΩ	
			REF ₀ -REF ₃	16	24		
Input Current		PD = 1			±10	μA	
Input Capacitance		Code = FF hex (Note 2)	REF ₄	120		pF	
			REF ₀ -REF ₃	30			
Channel-to-Channel Isolation		(Note 3)			-60	dB	
AC Feedthrough		(Note 4)			-70	dB	

Note 1: Input resistance is code dependent. The lowest input resistance occurs at code = 55 hex.

Note 2: Input capacitance is code dependent. The highest input capacitance occurs at code = FF hex.

Note 3: V_{REF} = 4Vp-p, 10kHz. Channel-to-channel isolation is measured by setting the code of one DAC to FF hex and setting the code of all other DACs to 00 hex.

Note 4: V_{REF} = 4Vp-p, 10kHz, DAC code = 00 hex.

Octal, 2-Wire Serial 8-Bit DAC with Rail-to-Rail Outputs

MAX521

ELECTRICAL CHARACTERISTICS (continued)

($V_{DD} = 5V \pm 10\%$, $V_{REF_} = 4V$, $R_L = 10k\Omega$, $C_L = 100pF$, $T_A = T_{MIN}$ to T_{MAX} , unless otherwise noted. Typical values are $T_A = +25^\circ C$.)

PARAMETER	SYMBOL	CONDITIONS	MIN	TYP	MAX	UNITS
DAC OUTPUTS						
Full-Scale Output Voltage			0		V_{DD}	V
Output Load Regulation		$OUT_ = 4V$, 0mA to 2.5mA	0.25		LSB	
		$V_{REF_} = V_{DD}$, code = FF hex, 0 μ A to 500 μ A, MAX521_C/E	1.5			
		$V_{REF_} = V_{DD}$, code = FF hex, 0 μ A to 500 μ A, MAX521BM	2.0			
Output Leakage Current		$OUT_ = 0V$ to V_{DD} , PD = 1			± 10	μ A
DIGITAL INPUTS SCL, SDA						
Input High Voltage	V_{IH}		0.7 V_{DD}			V
	V_{IL}		0.3 V_{DD}			
Input Current	I_{IN}	$0V \leq V_{IN} \leq V_{DD}$			± 10	μ A
Input Hysteresis	V_{HYST}	(Note 5)	0.05 V_{DD}			V
Input Capacitance	C_{IN}	(Note 5)			10	pF
DIGITAL INPUTS AD0, AD1						
Input High Voltage	V_{IN}		2.4			V
Input Low Voltage	V_{IL}				0.8	V
Input Leakage	I_{IN}	$V_{IN} = 0V$ to V_{DD}			± 10	μ A
DIGITAL OUTPUT SDA (Note 6)						
Output Low Voltage	V_{OL}	$I_{SINK} = 3mA$			0.4	V
		$I_{SINK} = 6mA$			0.6	
Three-State Leakage Current	I_L	$V_{IN} = 0V$ to V_{DD}			± 10	μ A
Three-State Output Capacitance	C_{OUT}	(Note 5)			10	pF
DYNAMIC PERFORMANCE						
Voltage Output Slew Rate		Positive and negative	MAX521_C	1.0		V/ μ s
			MAX521_E	0.7		
			MAX521BM	0.5		
Output Settling Time		To 1/2 LSB, 10k Ω and 100pF load (Note 7)	6			μ s
Digital Feedthrough		Code = 00 hex, all digital inputs from 0V to V_{DD}	5			nV-s
Digital-Analog Glitch Impulse		Code 128 to 127	12			nV-s
Signal to Noise + Distortion Ratio	SINAD	$V_{REF_} = 4Vp-p$ at 1kHz, $V_{DD} = 5V$, Code = FF hex	87			dB
Multiplying Bandwidth		$V_{REF_} = 4Vp-p$, 3dB bandwidth	1			MHz
Wideband Amplifier Noise			60			μ V _{RMS}
POWER REQUIREMENTS						
Supply Voltage	V_{DD}		4.5		5.5	V
Supply Current	I_{DD}	Normal mode, output unloaded, all digital inputs 0V or V_{DD}	MAX521_C	10	20	mA
			MAX521_E/BM	10	24	
		Power-down mode (PD = 1)	4	20	μ A	

Note 5: Guaranteed by design.

Note 6: I²C compatible mode.

Note 7: Output settling time is measured by taking the code from 00 hex to FF hex, and from FF hex to 00 hex.

Octal, 2-Wire Serial 8-Bit DAC with Rail-to-Rail Outputs

TIMING CHARACTERISTICS

($V_{DD} = 5V \pm 10\%$, $T_A = T_{MIN}$ to T_{MAX} , unless otherwise noted. Typical values are $T_A = +25^\circ C$.)

PARAMETER	SYMBOL	CONDITIONS	MIN	TYP	MAX	UNITS
Serial Clock Frequency	f_{SCL}		0		400	kHz
Bus Free Time Between a STOP and a START Condition	t_{BUF}		1.3			μs
Hold Time, (Repeated) Start Condition	$t_{HD, STA}$		0.6			μs
LOW Period of the SCL Clock	t_{LOW}		1.3			μs
High Period of the SCL Clock	t_{HIGH}		0.6			μs
Setup Time for a Repeated START Condition	$t_{SU, STA}$		0.6			μs
Data Hold Time	$t_{HD, DAT}$	(Note 8)	0		0.9	μs
Data Setup Time	$t_{SU, DAT}$		100			ns
Rise Time of Both SDA and SCL Signals, Receiving	t_R	(Note 9)	$20 + 0.1C_b$		300	ns
Fall Time of Both SDA and SCL Signals, Receiving	t_F	(Note 9)	$20 + 0.1C_b$		300	ns
Fall Time of SDA Transmitting (Note 6)	t_F	$I_{SINK} \leq 6mA$ (Note 9)	$20 + 0.1C_b$		250	ns
Setup Time for STOP Condition	$t_{SU, STO}$		0.6			μs
Capacitive Load for Each Bus Line	C_b				400	pF
Pulse Width of Spike Suppressed	t_{SP}	(Notes 10, 11)	0		50	ns

Note 8: A master device must provide a hold time of at least 300ns for the SDA signal (referred to V_{IL} of the SCL signal) in order to bridge the undefined region of SCL's falling edge.

Note 9: C_b = total capacitance of one bus line in pF. t_R and t_F measured between $0.3V_{DD}$ and $0.7V_{DD}$.

Note 10: An input filter on the SDA and SCL input suppresses noise spikes less than 50ns.

Note 11: Guaranteed by design.

Typical Operating Characteristics

($T_A = +25^\circ C$, unless otherwise noted.)

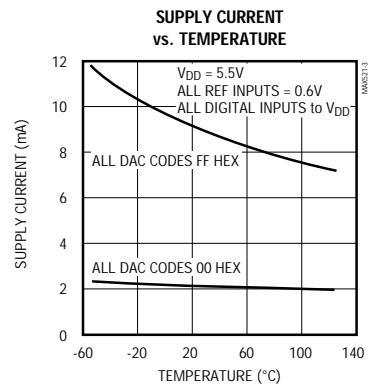
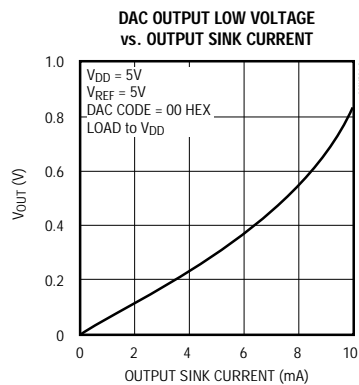
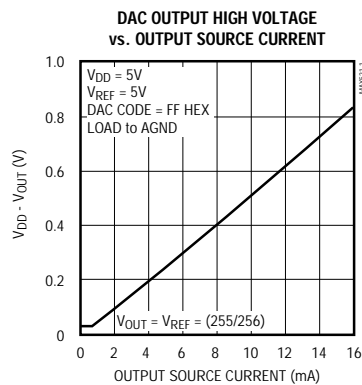

Octal, 2-Wire Serial 8-Bit DAC with Rail-to-Rail Outputs

Typical Operating Characteristics (continued)

(T_A = +25°C, unless otherwise noted.)

MAX521

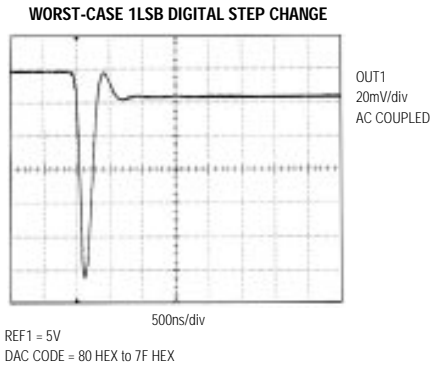
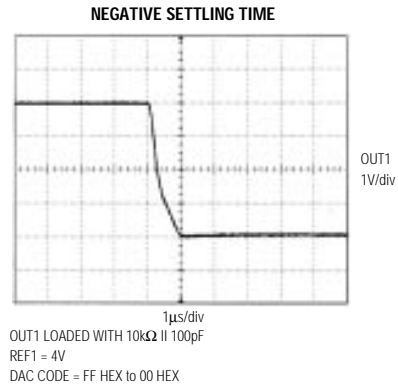
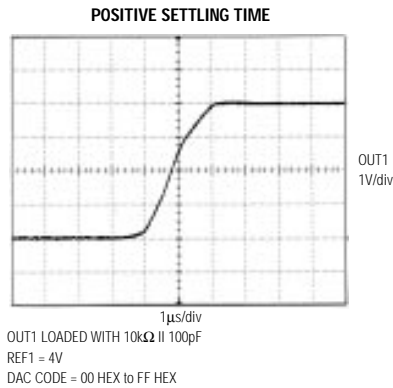
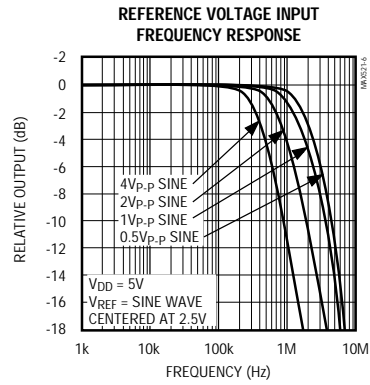
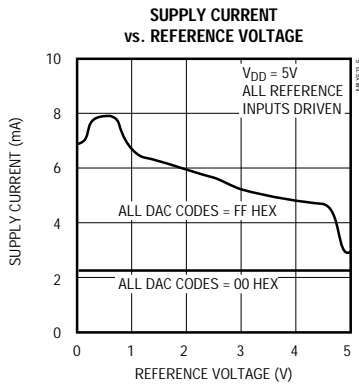
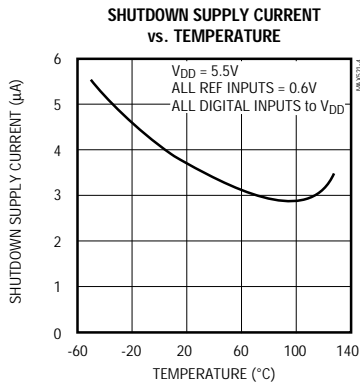

Octal, 2-Wire Serial 8-Bit DAC with Rail-to-Rail Outputs

Typical Operating Characteristics (continued)

(T_A = +25°C, unless otherwise noted.)

CLOCK FEEDTHROUGH

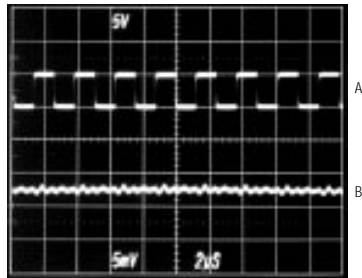

A = SCL, 400kHz, 5V/div
B = OUT1, 5mV/div
DAC CODE = 7F HEX
REF1 = 5V

REFERENCE FEEDTHROUGH AT 1kHz

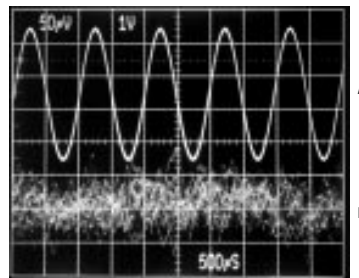

A = REF1, 1V/div (4Vp-p)
B = OUT1, 50µV/div, UNLOADED
FILTER PASSBAND = 100Hz to 10kHz
DAC CODE = 00 HEX

REFERENCE FEEDTHROUGH AT 10kHz

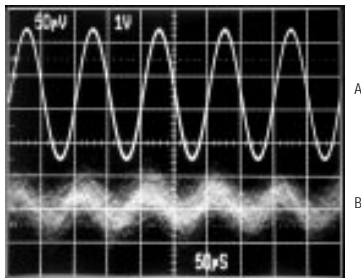

A = REF1, 1V/div (4Vp-p)
B = OUT1, 50µV/div, UNLOADED
FILTER PASSBAND = 1kHz to 100kHz
DAC CODE = 00 HEX

REFERENCE FEEDTHROUGH AT 100kHz

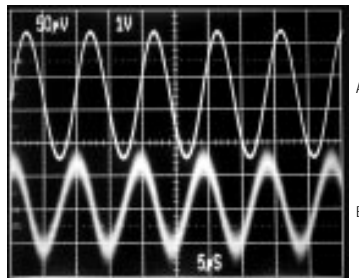

A = REF1, 1V/div (4Vp-p)
B = OUT1, 50µV/div, UNLOADED
FILTER PASSBAND = 10kHz to 1MHz
DAC CODE = 00 HEX

Octal, 2-Wire Serial 8-Bit DAC with Rail-to-Rail Outputs

MAX521

Pin Description

PIN		NAME	FUNCTION
DIP	SO/SSOP		
1	1	OUT1	DAC1 Voltage Output
2	2	OUT0	DAC0 Voltage Output
3	3	REF1	Reference Voltage Input for DAC1
4	4	REF0	Reference Voltage Input for DAC0
—	7, 9, 16, 20	N.C.	No Connect—not internally connected.
5	5	DGND	Digital Ground
6	6	AGND	Analog Ground
7	8	SCL	Serial Clock Input
8	10	SDA	Serial Data Input
9	11	OUT4	DAC4 Voltage Output
10	12	OUT5	DAC5 Voltage Output
11	13	OUT6	DAC6 Voltage Output
12	14	OUT7	DAC7 Voltage Output
13	15	AD0	Address Input 0; sets IC's slave address
14	17	AD1	Address Input 1; sets IC's slave address
15	18	V _{DD}	Power Supply, +5V
16	19	REF4	Reference Voltage Input for DACs 4, 5, 6, and 7
17	21	REF3	Reference Voltage Input for DAC3
18	22	REF2	Reference Voltage Input for DAC2
19	23	OUT3	DAC3 Voltage Output
20	24	OUT2	DAC2 Voltage Output

Detailed Description

Serial Interface

The MAX521 uses a simple two-wire serial interface requiring only two I/O lines (2-wire bus) of a standard microprocessor port. Figure 1 shows the timing diagram for signals on the wire bus. Figure 2 shows the typical application of the MAX521. The 2-wire bus can have several devices (in addition to the MAX521) attached. The two bus lines (SDA and SCL) must be high when the bus is not in use. When in use, the port bits are toggled to generate the appropriate signals for SDA and SCL. External pull-up resistors are not required on these lines. The MAX521 can be used in applications where pull-up resistors are required (such as in I²C systems) to maintain compatibility with the existing circuitry.

The MAX521 is a receive-only device and must be controlled by a bus master device. The MAX521 operates at SCL rates up to 400kHz. A master device sends information to the MAX521 by transmitting the MAX521's address over the bus and then transmitting the desired information. Each transmission consists of a START condition, the MAX521's programmable slave address, one or more command-byte/output-byte pairs (or a command byte alone, if it is the last byte in the transmission), and finally, a STOP condition (Figure 3).

The address byte and pairs of command and output bytes are transmitted between the START and STOP conditions. The SDA state is allowed to change only while SCL is low. The only exceptions to this are the START and STOP conditions. SDA's state is sampled, and therefore must remain stable while SCL is high. Data is transmitted in 8-bit bytes. Nine clock cycles are required to transfer the data bits to the MAX521. Set SDA low during the 9th clock cycle as the MAX521 pulls SDA low during this time. R_C (see Figure 2) limits the current that flows during this time if SDA stays high for short periods of time.

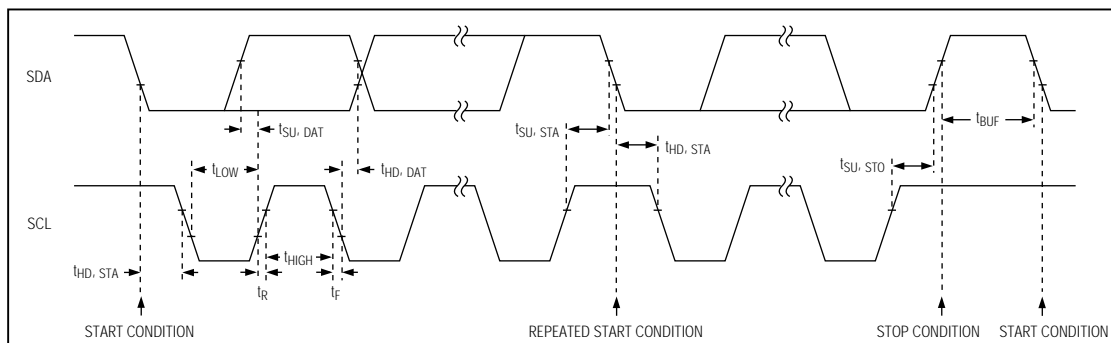

Figure 1. Two-Wire Serial Interface Timing Diagram

Octal, 2-Wire Serial 8-Bit DAC with Rail-to-Rail Outputs

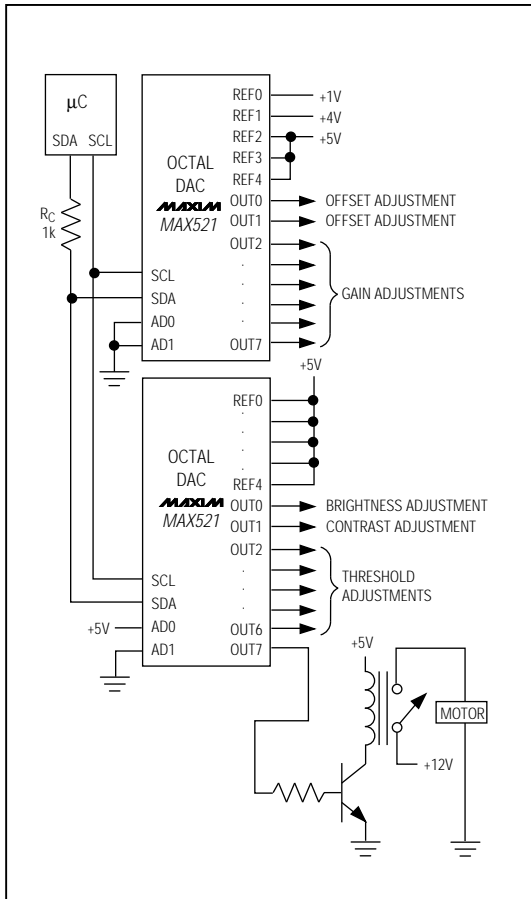

Figure 2. MAX521 Typical Application Circuit

The START and STOP Conditions

When the bus is not in use, both SCL and SDA must be high. A bus master signals the beginning of a transmission with a START condition by transitioning SDA from high to low while SCL is high (Figure 4). When the master has finished communicating with the slave, it issues a STOP condition by transitioning SDA from low to high while SCL is high. The bus is then free for another transmission.

The Slave Address

The MAX521's slave address is seven bits long (Figure 5). The first five bits (MSBs) of the slave address have been factory programmed and are always 01010. The state of the MAX521 inputs AD0 and AD1 determine the final two bits of the 7-bit slave address. These input pins may be connected to V_{DD} or DGND, or they may be actively driven by TTL or CMOS logic levels. There are four possible slave addresses for the MAX521, and therefore a maximum of four such devices may be on the bus at one time. The eighth bit (LSB) in the slave address byte should be low when writing to the MAX521.

The MAX521 watches the bus continuously, waiting for a START condition followed by its slave address. When it recognizes its slave address, it is ready to accept data.

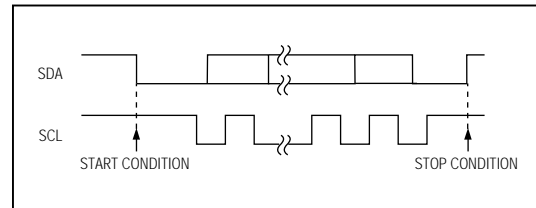

Figure 4. All communications begin with a START condition and end with a STOP condition, both generated by a bus master.

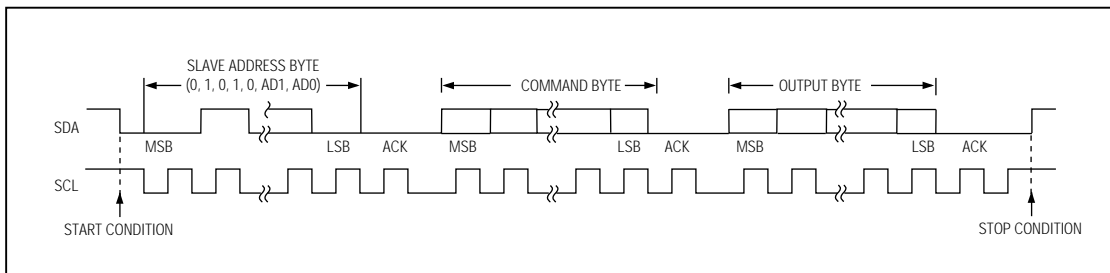

Figure 3. A Complete Serial Transmission

Octal, 2-Wire Serial 8-Bit DAC with Rail-to-Rail Outputs

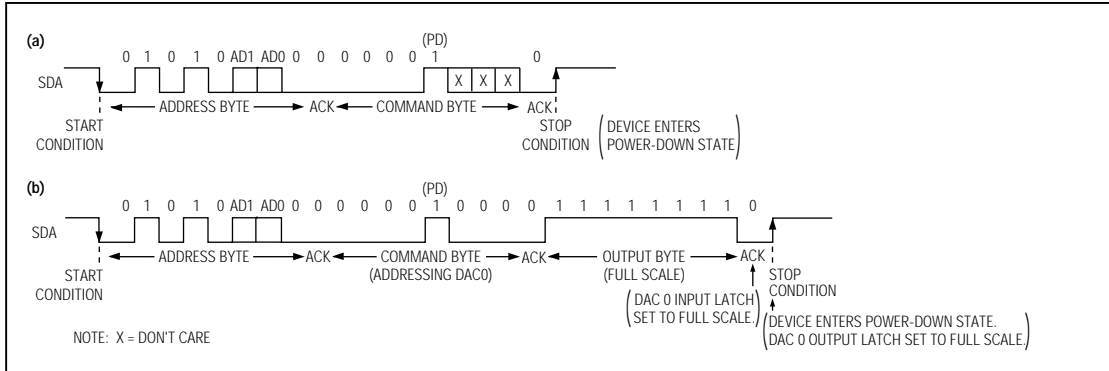

Figure 8. Entering the Power-Down State

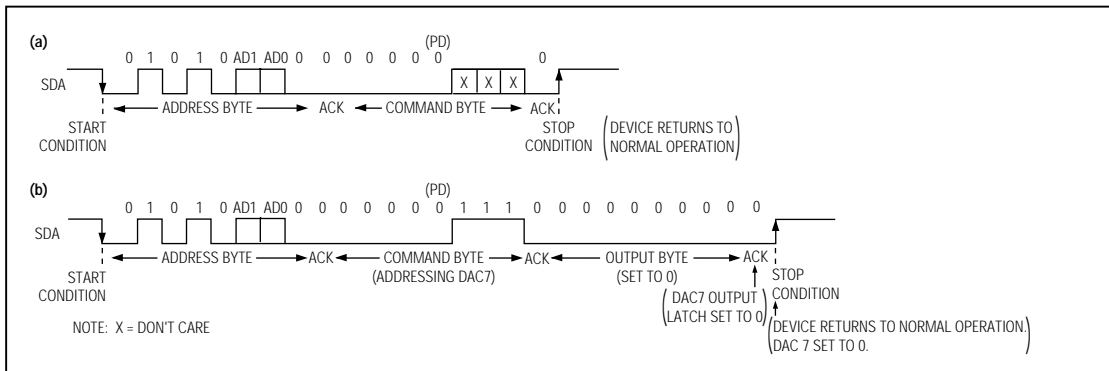

Figure 9. Returning to Normal Operation from Power-Down

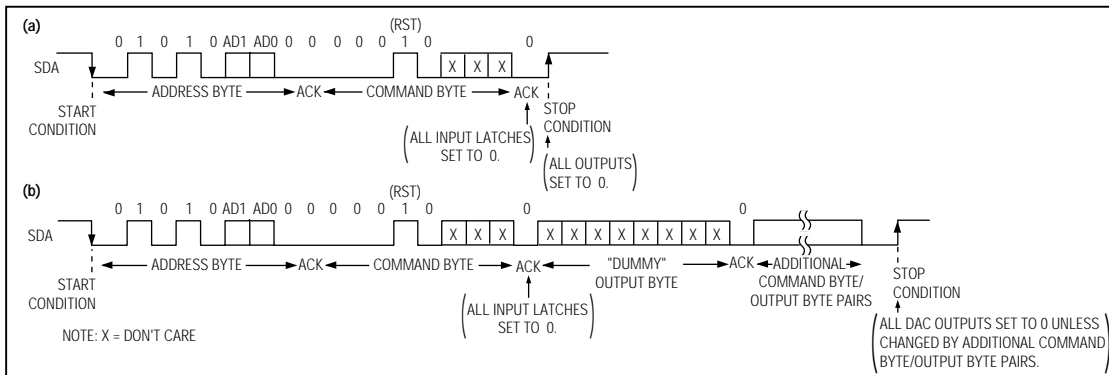

Figure 10. Resetting DAC Outputs

Octal, 2-Wire Serial 8-Bit DAC with Rail-to-Rail Outputs

MAX521

I²C Compatibility

The MAX521 is fully compatible with existing I²C systems. SCL and SDA are high-impedance inputs; SDA has an open drain which pulls the data line low during the 9th clock pulse. Figure 11 shows the MAX521 being used in a typical I²C application.

Additional START Conditions

It is possible to interrupt a transmission to a MAX521 with a new START (repeated start) condition (perhaps addressing another device), which leaves the input latches with data that has not been transferred to the output latches (Figure 12). Only the currently addressed MAX521 will recognize a STOP condition and transfer data to its output latches. If the MAX521 is left with data in its input latches, the data can be transferred to the output latches the next time the device is addressed, as long as it receives at least one command byte and a STOP condition.

Early Stop Conditions

The addressed MAX521 recognizes a STOP condition at any point in a transmission. If the STOP occurs during a command byte, all previous uninterrupted command and output byte pairs are accepted, the interrupted command byte is ignored, and the transmission ends (Figure 13a). If the STOP occurs during an output byte, all previous uninterrupted command and output byte pairs are accepted, the final command byte's PD and RST bits are accepted, the interrupted output byte is ignored, and the transmission ends (Figure 13b).

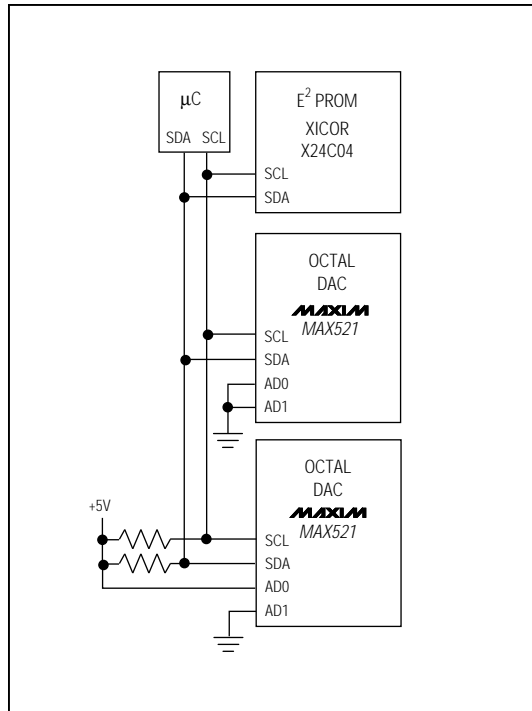

Figure 11. MAX521 Used in a Typical I²C Application Circuit

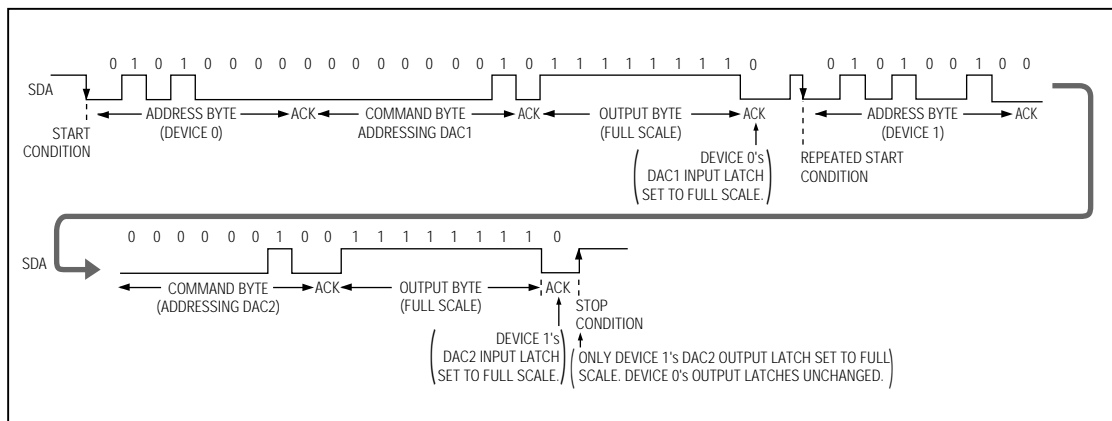

Figure 12. Repeated START Conditions

Octal, 2-Wire Serial 8-Bit DAC with Rail-to-Rail Outputs

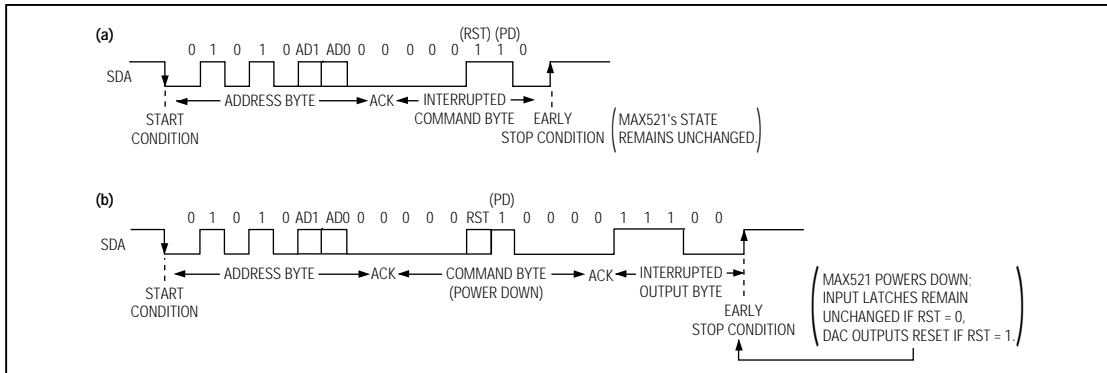

Figure 13. Early STOP Conditions

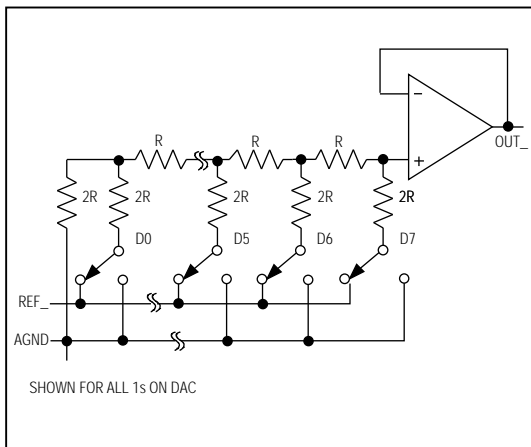

Figure 14. DAC Simplified Circuit Diagram

Analog Section

DAC Operation

The MAX521 contains eight matched voltage-output DACs. The DACs are inverted R-2R ladder networks that convert 8-bit digital words into equivalent analog output voltages in proportion to the applied reference voltages. DAC0-DAC3 each have separate reference inputs while DAC4-DAC7 all share a common reference input. Figure 14 shows a simplified diagram of one of the eight DACs.

Reference Inputs

The MAX521 can be used for multiplying applications. The reference accepts a 0V to V_{DD} voltage, both DC and AC signals. The voltage at each REF input sets the full-scale output voltage for its respective DAC(s). The reference voltage must be positive. The DAC's input impedance is code dependent, with the lowest value occurring when the input code is 55 hex or 0101 0101, and the maximum value occurring when the input code is 00 hex. Since the REF input resistance (R_{IN}) is code dependent, it must be driven by a circuit with low output impedance (no more than $R_{IN} \div 2000$) to maintain output linearity. The REF input capacitance is also code dependent, with the maximum value occurring at code FF hex (typically 120pF for REF4, and 30pF for REF0-REF3). The output voltage for any DAC can be represented by a digitally programmable voltage source as: $V_{OUT} = (N \times V_{REF}) / 256$, where N is the numerical value of the DAC's binary input code.

Output Buffer Amplifiers

The MAX521 voltage outputs (OUT0-OUT7) are internally buffered precision unity-gain followers that slew up to $1V/\mu s$. The outputs can swing from 0V to V_{DD} . With a 0V to 4V (or 4V to 0V) output transition, the amplifier outputs typically settle to 1/2LSB in $6\mu s$ when loaded with $10k\Omega$ in parallel with 100pF. The buffer amplifiers are stable with any combination of resistive loads $\geq 2k\Omega$ and capacitive loads $\leq 300pF$.

The MAX521 is designed for unipolar-output, single-quadrant multiplication where the output voltages and the reference inputs are positive with respect to AGND. Table 1 shows the unipolar code.

Octal, 2-Wire Serial 8-Bit DAC with Rail-to-Rail Outputs

MAX521

Table 1. Unipolar Code Table

DAC CONTENTS	ANALOG OUTPUT
11111111	$+V_{REF} \left(\frac{255}{256} \right)$
10000001	$+V_{REF} \left(\frac{129}{256} \right)$
10000000	$+V_{REF} \left(\frac{128}{256} \right) = \frac{V_{REF}}{2}$
01111111	$+V_{REF} \left(\frac{127}{256} \right)$
00000001	$+V_{REF} \left(\frac{1}{256} \right)$
00000000	0V

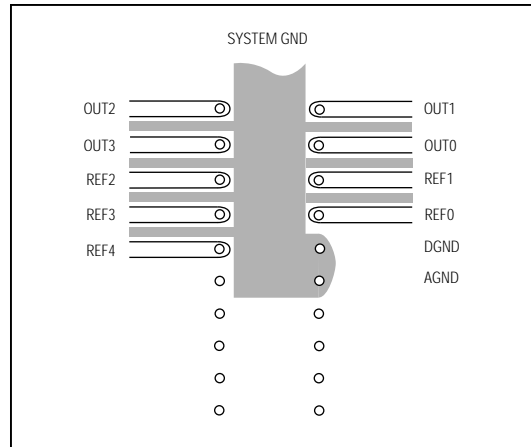

Figure 15. PC Board Layout for Minimizing Crosstalk (bottom view, DIP package)

Applications Information

Power-Supply Bypassing and Ground Management

Bypass V_{DD} with a $0.1\mu\text{F}$ capacitor, located as close to V_{DD} and DGND as possible. The analog ground (AGND) and digital ground (DGND) pins should be connected in a "star" configuration to the highest quality ground available, which should be located as close to the MAX521 as possible.

Careful PC board layout minimizes crosstalk among DAC outputs, reference inputs, and digital inputs. Figure 15 shows the suggested PC board layout to minimize crosstalk.

Octal, 2-Wire Serial 8-Bit DAC with Rail-to-Rail Outputs

Ordering Information (continued)

PART	TEMP. RANGE	PIN-PACKAGE	TUE (LSB)
MAX521AEPP	-40°C to +85°C	20 Plastic DIP	1
MAX521BEPP	-40°C to +85°C	20 Plastic DIP	2
MAX521AEWG	-40°C to +85°C	24 Wide SO	1
MAX521BEWG	-40°C to +85°C	24 Wide SO	2
MAX521AEAG	-40°C to +85°C	24 SSOP	1
MAX521BEAG	-40°C to +85°C	24 SSOP	2
MAX521BMJP	-55°C to +125°C	20 CERDIP**	2

* Dice are specified at $T_A = +25^\circ\text{C}$, DC parameters only.
 **Contact factory for availability.

Pin Configurations (continued)

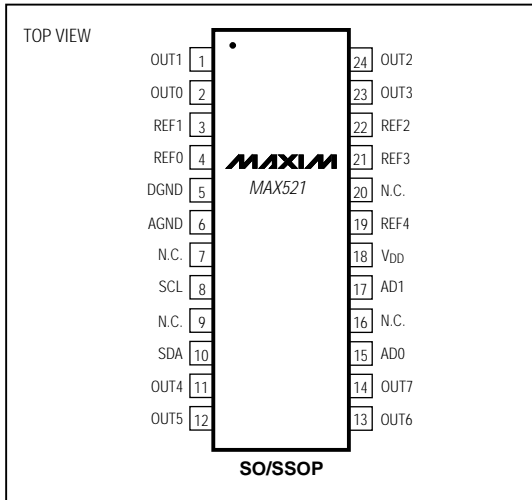

Chip Topography

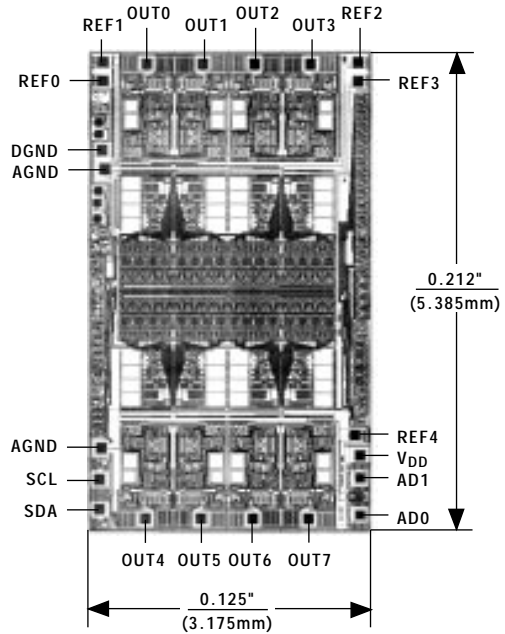

TRANSISTOR COUNT: 4518
 SUBSTRATE CONNECTED TO V_{DD}

Octal, 2-Wire Serial 8-Bit DAC with Rail-to-Rail Outputs

Package Information

MAX521

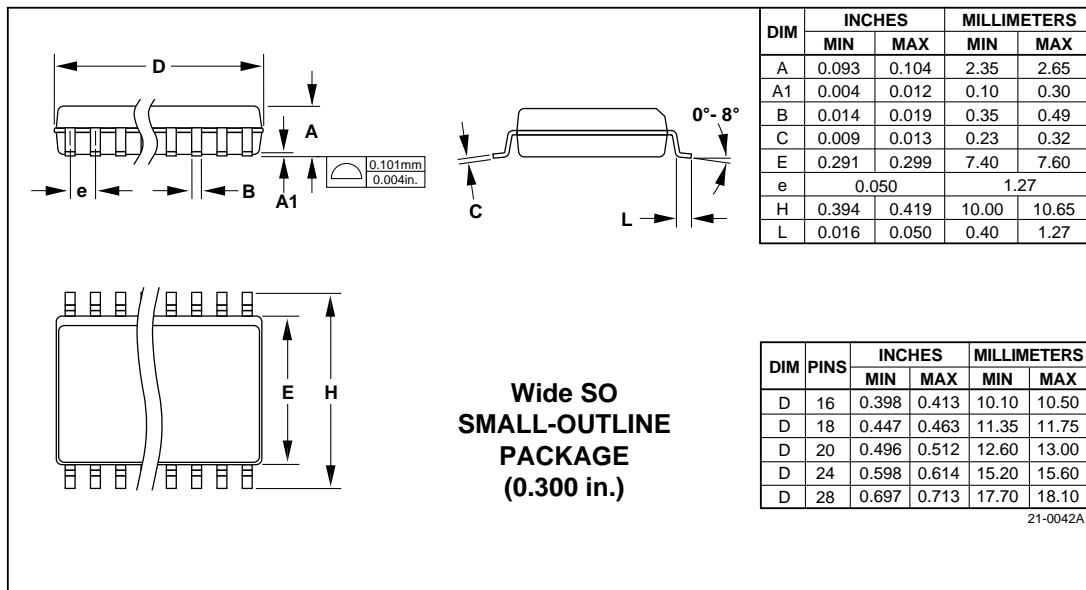
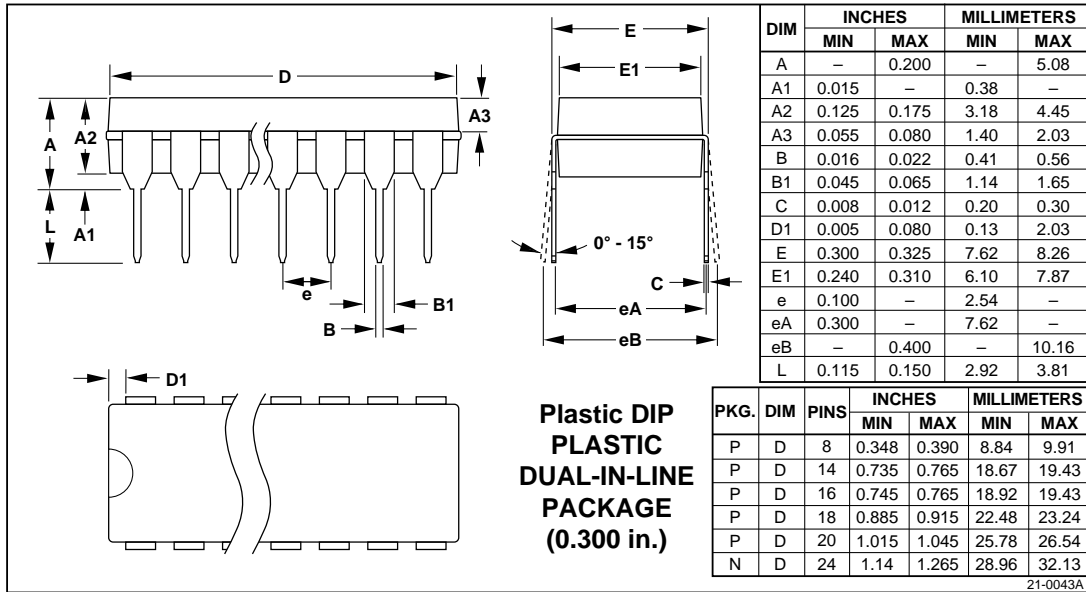

Octal, 2-Wire Serial 8-Bit DAC with Rail-to-Rail Outputs

Package Information (continued)

**SSOP
SHRINK
SMALL-OUTLINE
PACKAGE**

DIM	INCHES		MILLIMETERS	
	MIN	MAX	MIN	MAX
A	0.068	0.078	1.73	1.99
A1	0.002	0.008	0.05	0.21
B	0.010	0.015	0.25	0.38
C	0.004	0.008	0.09	0.20
D	SEE VARIATIONS			
E	0.205	0.209	5.20	5.38
e	0.0256 BSC		0.65 BSC	
H	0.301	0.311	7.65	7.90
L	0.025	0.037	0.63	0.95
α	0°	8°	0°	8°

DIM	PINS	INCHES		MILLIMETERS	
		MIN	MAX	MIN	MAX
D	14	0.239	0.249	6.07	6.33
D	16	0.239	0.249	6.07	6.33
D	20	0.278	0.289	7.07	7.33
D	24	0.317	0.328	8.07	8.33
D	28	0.397	0.407	10.07	10.33

21-0056A

Maxim cannot assume responsibility for use of any circuitry other than circuitry entirely embodied in a Maxim product. No circuit patent licenses are implied. Maxim reserves the right to change the circuitry and specifications without notice at any time.

16 _____ Maxim Integrated Products, 120 San Gabriel Drive, Sunnyvale, CA 94086 (408) 737-7600