



Technical catalogue - Edition 2010

Tmax. T Generation

Low voltage moulded-case
circuit-breakers up to 1600 A



Main characteristics

1



The ranges

2



Accessories

3



Characteristic curves and technical information

4



Wiring diagrams

5



Overall dimensions

6



Ordering codes

7

T GENERATION

TMAX. COMPLETE FREEDOM.



Tmax is freedom. Freedom now reaching up to 1600 A with the new Tmax T7 circuit-breaker. There's a boundless and highly diversified world of differing types of installations, requirements, needs and problems from 0 to 1600 A. With T Generation everything becomes simple and rational – seven sizes to find the solutions you're looking for.

BE FREE TO SIZE ANY TYPE OF INSTALLATION IN AN IDEAL WAY AT ALL TIMES.

Thanks to the seven sizes and a complete series of magnetic only, thermomagnetic and electronic trip units.

And also a wide range of accessories and the possibility of selecting dedicated ranges for all market applications, even the most specific and advanced ones.

BE FREE TO INSTALL ALL THE SIZES WITHOUT ANY DIFFICULTY.

T Generation is undeniably the family of moulded-case circuit-breakers with the top performance/size ratio available on the market, so can you imagine how much more space there is for cabling and how simply you'll be able to carry it out? And further, what about the reduced dimensions of the switchboard?

ATION



BE FREE TO RIDE THE MOST ADVANCED TECHNOLOGY.

It is thanks to this technology that T Generation offers you performances which were out of the question until now in circuit-breakers with these dimensions. And there are some exclusive technical solutions which only ABB SACE can offer you, such as the brand new electronic trip units designed for the new Tmax T7 or the new rapid accessory fitting system.

FREEDOM OF TOTALLY SAFE SELECTION.

The safety of knowing that behind Tmax there's ABB SACE's strong and constant commitment to continually search for excellence of quality at the base of each product and service. ABB quality.

TMAX T1, T2 AND T3. ALL SOLUTIONS PERFECTLY COORDINATED, UP TO 250 A.



Tmax T1, T2 and T3 – the three “little ones” of the Tmax family - were thought up from the beginning to work together. You can select functions and performances which until now couldn't be found in circuit-breakers with these dimensions. Perfect up to 250 A.

There are so many characteristics common to the three sizes. The single depth (70 mm) of the three pieces of apparatus making installation truly simpler, the new arcing chambers produced with a gasifying material, and an innovative construction system allowing the arc extinction time to be reduced.

All three sizes are fitted with adjustment of the thermal threshold as standard and have new - three-pole and four-pole - residual

current releases, designed and constructed to optimise space in the switchboard and simplify coupling with the circuit-breaker. Tmax T1, T2 and T3 have a completely standardised range of accessories.





TMAX T1. THE LITTLE ONE THAT'S REALLY BIG.

Thanks to its extremely compact dimensions, Tmax T1 is a unique circuit-breaker in its category. Compared with any other circuit-breaker with the same performance (160 A – up to 36 kA at 415 V AC), the overall dimensions of the apparatus are notably smaller.

TMAX T2. INTELLIGENCE AND HIGH PERFORMANCE IN THE PALM OF YOUR HAND.

Tmax T2 is the only 160 A circuit-breaker available with such high performances in such very limited overall



dimensions. A breaking capacity of 85 kA at 415 V AC can be achieved. Tmax T2 can be fitted with a latest generation electronic trip unit.

TMAX T3. 250 A IN A DEPTH OF 70 MM FOR THE FIRST TIME.

Tmax T3 is the first circuit-breaker which carries 250 A in considerably limited overall dimensions compared with any other similar apparatus – a really large step forward for this type of equipment.

Tmax T3 allows coordinations for motor protection to be made up to a power of 90 kW at 415 V AC.

TMAX T4, T5 AND T6. BE FREE TO CHOOSE UP TO 1000 A.



Tmax T4, T5 and T6 are the moulded-case circuit-breakers with the best performance/size ratio on the market. Their application possibilities are practically unlimited, thanks to their dedicated and specific ranges, advanced electronics, as well as a complete and standardised range of accessories. The top quality materials and innovative construction techniques used by ABB SACE mean Tmax circuit-breakers can guarantee truly exceptional performances, with a really high rated current/volume ratio. For example, T4 and T5 guarantee a breaking capacity up to 200 kA at 415 V AC and an extraordinary 80 kA at 690 V AC. Moreover, they complete the range of applications up to 1150 V in alternating current and 1000 V in direct current.

The series of electronic trip units, equipped with latest generation technology, offers solutions exclusive to ABB. T4, T5 and T6 have the same depth, simplifying their positioning in the switchboard compartments, and also have a complete, standardised and unified range of accessories available, simplifying selection, making them flexible to use and reducing stocks.

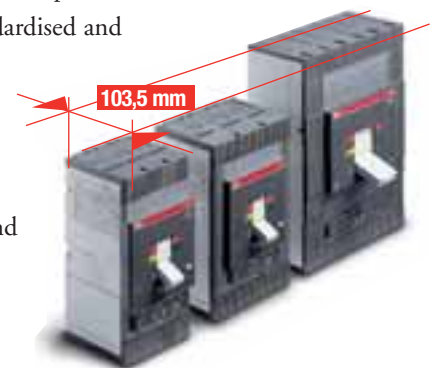



NEW PR223EF TRIP UNIT. THIS IS WHERE THE EXCLUSIVE INNOVATION IS TO BE FOUND.

The new PR223EF trip unit with the EFDP system offers two characteristics which until now were antithetic: selectivity and rapid tripping. With the new PR223EF, a new range up to 1000 A has been conceived for specific needs requiring high selectivity values: rapid detection of the fault and no limit to the number of hierarchical levels of the distribution plant. With the EFDP system, the size of the apparatus inside the installation can be reduced and cable and busbar siz-

ing can be optimised. And the outcome? Considerable reductions in plant costs.

NEW PR223DS TRIP UNIT. FREEDOM OF CONTROL.

The new PR223DS trip unit has been conceived and built for power distribution circuit-breakers.

Now all the different electrical values of the installation can be measured. And that's not all – there are LEDs available on the front of the trip unit which signal some configurations and the presence of any alarms (overload, incorrect connections, etc.).



TMAX T7. FREEDOM TO THE NTH POWER.



The new Tmax T7, available in two versions up to 1600 A either with manual operating mechanism or motor operator, was conceived with a really revolutionary design for circuit-breakers of this type: advanced electronics, exceptional performances and new installation and accessory fitting solutions.

Flexibility is absolutely exceptional with Tmax T7: they can be installed both vertically and horizontally (in the withdrawable version, too), there are all types of terminals (among which, flat orientated rear terminals) and a new, faster and safer racking-out system for the moving part. Moreover, cabling is considerably facilitated by the reduced height.

A great news is the new rapid accessory wiring system. No wires inside the circuit-breaker, rapid, simple and safe connection to the external circuit, and no screws for fixing the external power supply cables.

The exclusive news of the new cable interlock provides notable benefits in terms of optimal sizing. By using this accessory it is possible to interlock two circuit-breakers in any position and, above all, to interlock a T7 with an air circuit-breaker as well. Impossible until today, this answer is ideal for automatic transfer switch solutions.



Special attention has been paid to the electronics and the results are there to be seen ... PR231, PR232, PR331 and PR332 are the new interchangeable electronic trip units, with modularity and rating-plugs which can be replaced by the customer.



The PR231 and PR232 trip units, with dip-switches for setting the protection thresholds, offer LEDs to signal protection tripped for each protection function: this means the reason for circuit-breaker tripping can always be found.

The PR332 is decidedly ahead of its time in the present reference panorama: fitted with a large graphic display, it allows all the information needed to be displayed simply and clearly. It also offers advanced protection functions (as well as the "classic" protection functions). For example, the exclusive data logger function allowing all the events and values before the fault to be recorded for later analysis.





Index

Overview of the Tmax family	1/2
General	1/4
Construction characteristics	
Modularity of the series	1/6
Distinguishing features of the series	1/8

Overview of the Tmax family



1



Circuit-breakers for AC-DC distribution

		T1 1p	T1
Size	[A]	160	160
In	[A]	16...160	16...160
Poles	[Nr]	1	3/4
Ue	[V]	(AC) 50 - 60 Hz 240	690
	[V]	(DC) 125	500
Icu (380-415 V AC)	[kA]	B 25* (220/230 V AC)	16
	[kA]	C	25
	[kA]	N	36
	[kA]	S	
	[kA]	H	
	[kA]	L	
	[kA]	V	



Circuit-breakers for zone selectivity

Size	[A]		
Poles	[Nr]		
Ue	[V]	(AC) 50 - 60 Hz	
EFDP zone selectivity			
ZS zone selectivity			



Circuit-breakers for motor protection

Size	[A]		
Poles	[Nr]		
Ue	[V]	(AC) 50 - 60 Hz	
Magnetic only trip unit, IEC 60947-2			
PR221DS-I trip unit, IEC 60947-2			
PR222MP trip unit, IEC 60947-4-1			
PR231/P-I trip unit, IEC 60947-2			



Circuit-breakers for use up to 1150 V AC and 1000 V DC

Size	[A]		
Poles	[Nr]		
Icu max	[kA]	1000 V AC	
	[kA]	1150 V AC	
	[kA]	1000 V DC	
		4 poles in series	



Switch-disconnectors

			T1D
Ith	[A]		160
Ie	[A]		125
Poles	[Nr]		3/4
Ue	[V]	(AC) 50 - 60 Hz	690
	[V]	(DC)	500
Icm	[kA]		2.8
Icw	[kA]		2

* For In 16 A and In 20 A: Icu @ 220/230 V AC = 16 kA

Note: ABB SACE's moulded-case circuit-breakers are also available in the versions according to UL Standards (see catalogue "ABB SACE molded case circuit-breakers - UL 489 and CSA C22.2 Standard").



T2	T3	T4	T5	T6	T7
160	250	250/320	400/630	630/800/1000	800/1000/1250/1600
1.6...160	63...250	20...320	320...630	630...1000	200...1600
3/4	3/4	3/4	3/4	3/4	3/4
690	690	690	690	690	690
500	500	750	750	750	
36	36	36	36	36	
50	50	50	50	50	50
70		70	70	70	70
85		120	120	100	120
		200	200		150

T4	T5	T6	T7
250/320	400/630	630/800/1000	800/1000/1250/1600
3/4	3/4	3/4	3/4
690/1000	690/1000	690	690
■	■	■	■

T2	T3	T4	T5	T6	T7
160	250	250/320	400/630	800	800/1000/1250
3	3	3	3	3	3
690	690	690	690	690	690
■	■	■			
■		■	■	■	
		■	■	■	
					■

T4	T5	T6
250	400/630	630/800
3/4	3/4	3/4
20	20	12
12	12	
40	40	40

T3D	T4D	T5D	T6D	T7D
250	250/320	400/630	630/800/1000	1000/1250/1600
200	250/320	400/630	630/800/1000	1000/1250/1600
3/4	3/4	3/4	3/4	3/4
690	690	690	690	690
500	750	750	750	750
5.3	5.3	11	30	52.2
3.6	3.6	6	15	20

General

Tmax family is now available as a complete range of moulded case circuit-breakers up to 1600 A. All the circuit-breakers, both three-pole and four-pole, are available in the fixed version; the sizes T2, T3, T4 and T5 in the plug-in version and T4, T5, T6 and T7 in the withdrawable one as well. With the same frame size, the circuit-breakers in the Tmax family, are available with different breaking capacities and different rated uninterrupted currents.

Rated uninterrupted current [A]

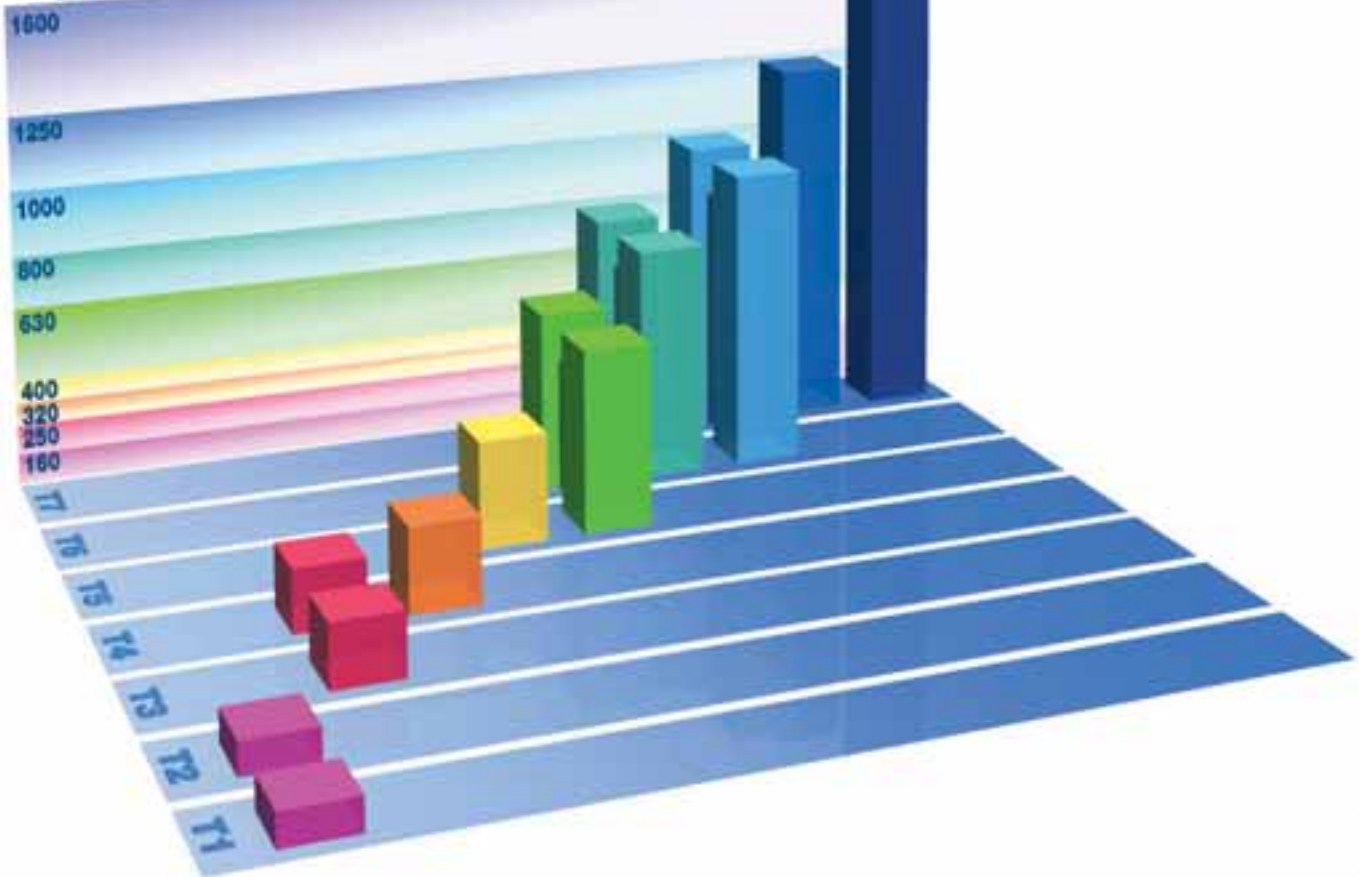

1SDC210014F0001

The electric arc interruption system used on the Tmax circuit-breakers allows the short-circuit currents of very high value to be interrupted extremely rapidly. The considerable opening speed of the contacts, the dynamic blasting action carried out by the magnetic field and the structure of the arcing chamber contribute to extinguishing the arc in the shortest possible time, notably limiting the value of the specific let-through energy I^2t and the current peak.

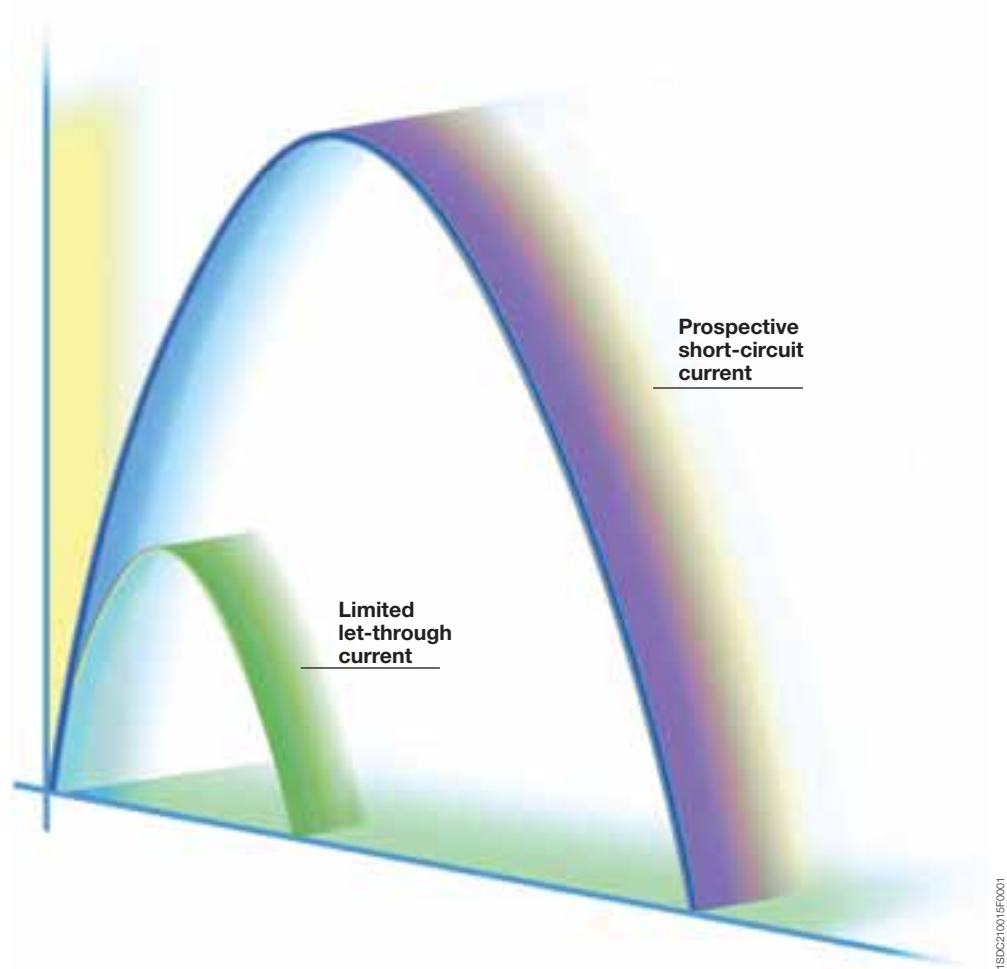

Construction characteristics

Modularity of the series

1

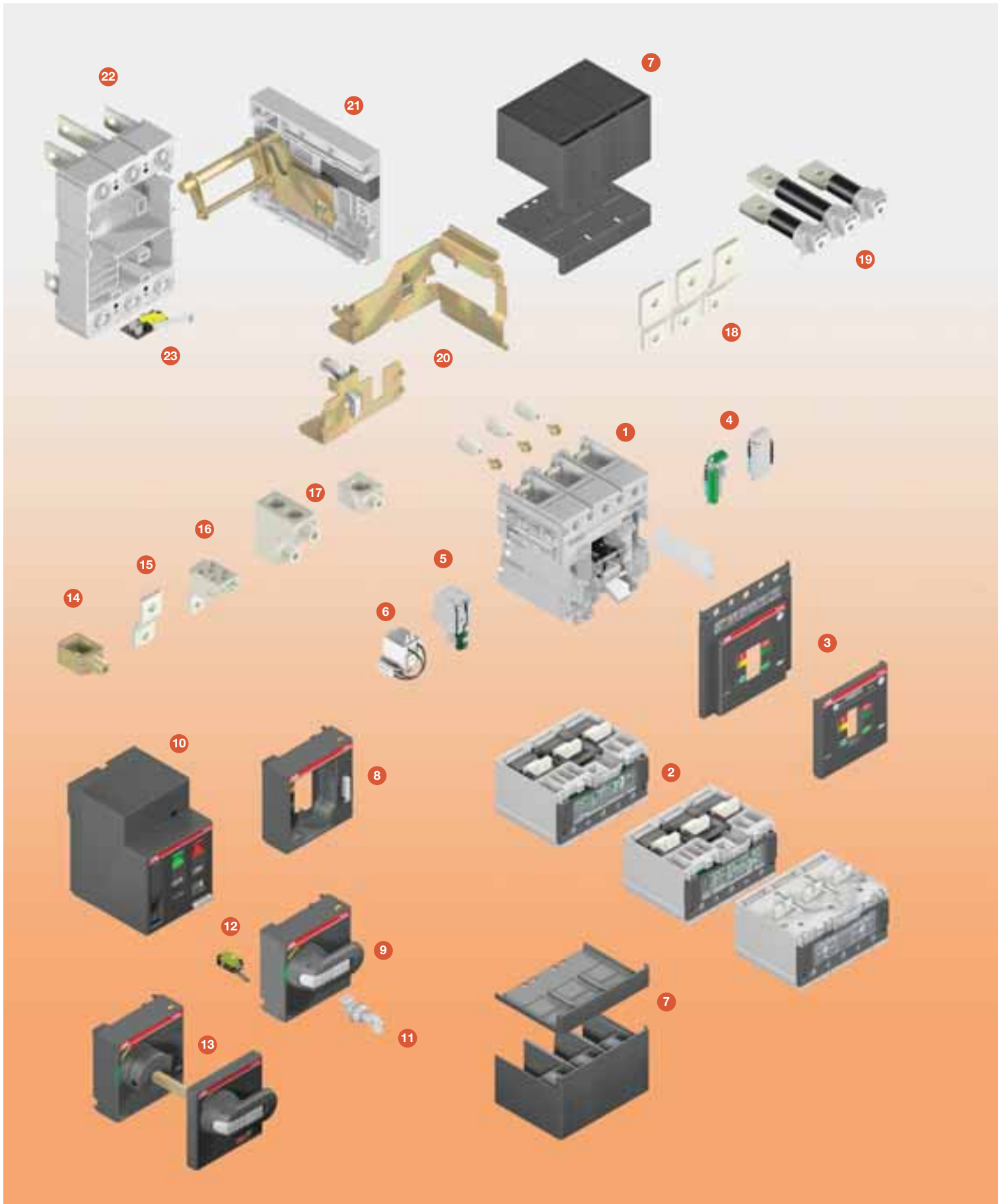



Starting from the fixed version circuit-breaker, all the other versions used for various requirements are obtained by means of mounting conversion kits.

The following are available:

- kit for converting a fixed circuit-breaker into the moving part of a plug-in and withdrawable one
- circuit-breaker fixed parts for plug-in and withdrawable circuit-breakers
- conversion kit for the connection terminals.

Various accessories are also available:

1. Breaking unit
2. Trip units
3. Front
4. Auxiliary contacts - AUX and AUX-E
5. Undervoltage release - UVR
6. Shunt opening release - SOR and P-SOR
7. Terminal covers
8. Front for lever operating mechanism - FLD
9. Direct rotary handle - RHD
10. Stored energy motor operator - MOE
11. Key lock - KLF
12. Early auxiliary contact - AUE
13. Transmitted rotary handle - RHE
14. Front terminal for copper cable - FC Cu
15. Front extended terminal - EF
16. Multi-cable terminal (only for T4) - MC
17. Front terminal for copper-aluminium - FC CuAl
18. Front extended spread terminal - ES
19. Rear orientated terminal - R
20. Conversion kit for plug-in/withdrawable versions
21. Guide of fixed part in the withdrawable version
22. Fixed part - FP
23. Auxiliary position contact - AUP
24. Phase separators
25. PR010T
26. TT1
27. Racking out crank handle
28. Residual current release.

Construction characteristics

Distinguishing features of the series



Double insulation

Tmax has double insulation between the live power parts (excluding the terminals) and the front parts of the apparatus where the operator works during normal operation of the installation. The seat of each electrical accessory is completely segregated from the power circuit, thereby preventing any risk of contact with live parts, and, in particular, the operating mechanism is completely insulated in relation to the powered circuits.

Furthermore, the circuit-breaker has oversized insulation, both between the live internal parts and in the area of the connection terminals. In fact, the distances exceed those required by the IEC Standards and comply with what is foreseen by the UL 489 Standard.



Positive operation

The operating lever always indicates the precise position of the moving contacts of the circuit-breaker, thereby guaranteeing safe and reliable signals, in compliance with the prescriptions of the IEC 60073 and IEC 60417-2 Standard (I = Closed; O = Open; yellow-green line = Open due to protection trip). The circuit-breaker operating mechanism has free release regardless of the pressure on the lever and the speed of the operation. Protection tripping automatically opens the moving contacts: to close them again, the operating mechanism must be reset by pushing the operating lever from the intermediate position into the lowest open position.

Isolation behaviour

In the open position, the circuit-breaker guarantees circuit in compliance with the IEC 60947-2 Standard. The oversized insulation distances guarantee there are no leakage currents and dielectric resistance to any overvoltages between input and output.

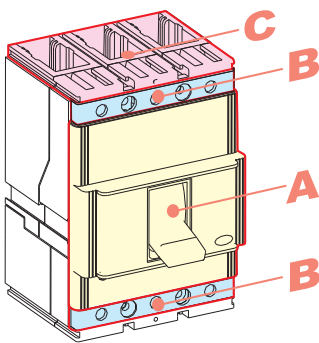

Degrees of protection

The table indicates the degrees of protection guaranteed by the Tmax circuit-breakers according to the prescriptions of the IEC 60529 Standard:

	With front	Without front ⁽²⁾	Without terminal covers	With high terminal covers	With low terminal covers	With IP40 protection kit on the front
A	IP 40⁽³⁾	IP 20	-	-	-	-
B⁽⁴⁾	IP 20	IP 20	IP 20	IP 40	IP 40	IP 40
C	-	-	-	IP 40⁽¹⁾	IP 30⁽¹⁾	-

⁽¹⁾ After correct installation

⁽²⁾ During installation of the electrical accessories

⁽³⁾ Also for front for lever operating mechanism and direct rotary handle

⁽⁴⁾ Only for T1...T6

The fixed parts are always preset with IP20 degree of protection. IP54 degree of protection can be obtained with the circuit-breaker installed in a switchboard fitted with a rotary handle operating mechanism transmitted on the compartment door and special kit (RHE – IP54).

Operating temperature

The Tmax circuit-breakers can be used in ambient conditions where the surrounding air temperature varies between $-25\text{ }^{\circ}\text{C}$ and $+70\text{ }^{\circ}\text{C}$, and stored in ambients with temperatures between $-40\text{ }^{\circ}\text{C}$ and $+70\text{ }^{\circ}\text{C}$.

The circuit-breakers fitted with thermomagnetic trip units have their thermal element set for a reference temperature of $+40\text{ }^{\circ}\text{C}$. For temperatures other than $+40\text{ }^{\circ}\text{C}$, with the same setting, there is a thermal trip threshold variation as shown in the table on page 4/50 and following.

The electronic trip units do not undergo any variations in performance as the temperature varies but, in the case of temperatures exceeding $+40\text{ }^{\circ}\text{C}$, the maximum setting for protection against overloads L must be reduced, as indicated in the derating graph on page 4/37 and following, to take into account the heating phenomena which occur in the copper parts of the circuit-breaker passed through by the phase current.

For temperatures above $+70\text{ }^{\circ}\text{C}$ the circuit-breaker performances are not guaranteed. To ensure service continuity of the installations, the way to keep the temperature within acceptable levels for operation of the various devices and not only of the circuit-breakers must be carefully assessed, such as using forced ventilation in the switchboards and in their installation room.



1SDC210015D0205

Altitude

Up to an altitude of 2000 m the Tmax circuit-breakers do not undergo any alterations in their rated performances. As the altitude increases, the atmospheric properties are altered in terms of composition, dielectric resistance, cooling capacity and pressure. Therefore the circuit-breaker performances undergo derating, which can basically be measured by means of the variation in significant parameters such as the maximum rated operating voltage and the rated uninterrupted current.

Altitude	[m]	2000	3000	4000	5000
Rated service voltage, Ue	[V~]	690	600	500	440
Rated uninterrupted current	%	100	98	93	90

Construction characteristics

Distinguishing features of the series

1



Electromagnetic compatibility

Operation of the protections is guaranteed in the presence of interferences caused by electronic apparatus, atmospheric disturbances or electrical discharges by using the electronic trip units and the electronic residual current releases. No interference with other electronic apparatus near the place of installation is generated either. This is in compliance with the IEC 60947-2 Appendix B + Appendix F Standards and European Directive No. 89/336 regarding EMC - electromagnetic compatibility.



Tropicalisation

Circuit-breakers and accessories in the Tmax series are tested in compliance with the IEC 60068-2-30 Standard, carrying out 2 cycles at 55 °C with the "variant 1" method (clause 7.3.3). The suitability of the Tmax series for use under the most severe environmental conditions is therefore ensured with the hot-humid climate defined in the climatograph 8 of the IEC 60721-2-1 Standards thanks to:

- moulded insulating cases made of synthetic resins reinforced with glass fibres;
- anti-corrosion treatment of the main metallic parts;
- Fe/Zn 12 zinc-plating (ISO 2081) protected by a conversion layer, free from hexavalent-cromium (ROHS-compliant), with the same corrosion resistance guaranteed by ISO 4520 class 2c;
- application of anti-condensation protection for electronic overcurrent releases and relative accessories.



Resistance to shocks and vibrations

The circuit-breakers are unaffected by vibrations generated mechanically and due to electromagnetic effects, in compliance with the IEC 60068-2-6 Standards and the regulations of the major classification organisations⁽¹⁾:

- RINA
- Det Norske Veritas
- Bureau Veritas
- Lloyd's register of shipping
- Germanischer Lloyd
- ABS
- Russian Maritime Register of Shipping.

The T1-T5 Tmax circuit-breakers are also tested, according to the IEC 60068-2-27 Standard, to resist shocks up to 12g for 11 ms. Please ask ABB SACE for higher performances in terms of resistance to shocks.

⁽¹⁾ Ask to ABB for Tmax certificates of approval.



1SDC210A41F0001



1SDC210A41F0001

Versions and types

All the Tmax circuit breakers are available in fixed versions, T2, T3, T4 and T5 in the plug-in version and T4, T5, T6^(*) and T7 also in the withdrawable one.

All the circuit breakers can be manually operated, by the operating lever or the rotary handle (direct or transmitted), and electrically operated. For this issue different solutions are available:

- The solenoid operator for T1, T2 and T3
- The stored energy motor operator for T4, T5 and T6
- T7 with the stored energy operating mechanism, gear motor for the automatic charging of the closing springs and shunt opening and closing releases.

Installation

Tmax circuit-breakers can be installed in the switchboards, mounted in any horizontal, vertical or lying down position on the back plate or on rails, without undergoing any derating of their rated characteristics. Tmax circuit-breakers can be installed easily in all types of switchboards, above all thanks to the possibility of being supplied either by top or bottom terminals, without jeopardizing the apparatus functionality^(**).

Apart from fixing on the base plate, T1, T2 and T3 can also be installed on DIN 50022 rails, thanks to the special fixing brackets.

Furthermore, the depth of 70 mm takes Tmax T3 to the same standard as the two smaller sizes, making assembly of circuit-breakers up to 250 A in standard switchboards even simpler. In fact, it is possible to prepare standardised support structures, facilitating the design stage and construction of the switchboard metalwork.

^(*) Not available on the 1000 A version.

^(**) For uses at a voltage of 1000 V, T4V250 and T5V400 in the fixed version, and T4L250 and T5L400 in the plug-in version must be supplied from above.

Construction characteristics

Distinguishing features of the series

Racking-out with the door closed

With Tmax T4, T5, T6 and T7 circuit-breakers, in the withdrawable version, the circuit-breaker can be racked-in and out with the compartment door closed, thereby increasing operator safety and allowing rationalisation of low voltage arc proof switchboards.

Racking out can only be carried out with the circuit-breaker open (for obvious safety reasons), using a special racking-out crank handle supplied with the conversion kit from fixed circuit-breaker to moving part of withdrawable circuit-breaker.



Range of accessories

The completeness and installation rationality of the Tmax series is also achieved thanks to innovative solutions in development of the accessories:

- single range of accessories for T1, T2 and T3; one for T4, T5 and T6, and one for T7, characterised by completeness and simplicity for installation. Harmonisation of the accessories allows reduction in stocks and greater service flexibility, offering increasing advantages for users of the Tmax series;
- new system of rapid assembly for internal electrical accessories of Tmax T7 without cables for the connections to the terminal box;
- same possibility of equipping with accessories, in terms of connection devices (terminals, terminal covers and phase separators), between fixed circuit-breakers and fixed parts of plug-in circuit-breakers for Tmax T2 and T3.
- moreover, Tmax offers a wide choice of residual current releases:
 - three-pole and four-pole RC221 and RC222 up to 250 A with T1, T2 and T3;
 - RC222 placed below, four-pole up to 500 A for T4 and T5;
 - RC223 (type B) also sensitive to currents with continuous slowly variable components (IEC 60947-2 Annex M), four-pole for T3 and T4, up to 250 A;
 - integrated residual current protection for PR332/P-LSIRc trip unit available for Tmax T7.



Compliance with Standards and company quality system

Tmax circuit-breakers and their accessories comply with the international IEC 60947-2 Standards and the EC directive:

- "Low Voltage Directives" (LVD) no. 2006/95/CE (replaces 72/23/EEC and subsequent amendments)
- Electromagnetic Compatibility Directive (EMC) no. 89/336 EEC.

Certification of compliance with the product Standards mentioned above is carried out, in accordance with the European EN 45011 Standard, by the Italian certification organisation ACAE (Association for Certification of Electrical Apparatus), member of the European organization LOVAG (Low Voltage Agreement Group) and by the Swedish certification organization SEMKO.

The Test Room at ABB SACE is accredited by SINAL (certificate No. 062). The Tmax series also has a range which has undergone certification according to the severe American UL 489 and CSA C22.2 Standards. Furthermore, the Tmax series is certified by the Russian GOST (Russia Certificate of Conformity) certification organisation. The pieces of apparatus comply with the prescriptions for on-board shipping installations and are approved by the major Naval Registers - Lloyd's Register of Shipping, Germanischer Lloyd, Bureau Veritas, Rina, Det Norske Veritas, Russian Maritime Register of Shipping, and ABS (please ask ABB SACE for confirmation about the versions available).

ABB SACE's Quality System complies with the international ISO 9001-2000 Standard (model for quality assurance in design, development, construction, installation and service assistance) and with the equivalent European EN ISO 9001 and Italian UNI EN ISO 9001 Standards.

The third certifying Organisation is RINA-QUACER. ABB SACE received the first certification in 1990 with three-year validity and this has now reached its fifth confirmation.

The new Tmax series has a hologram on the front, obtained using special anti-imitation techniques - a guarantee of the quality and genuineness of the circuit-breaker as an ABB SACE product. Attention to protection of the environment is another priority commitment for ABB SACE, and, as confirmation of this, the environmental management system has been certified by RINA. ABB SACE - the first industry in the electromechanical sector in Italy to obtain this recognition - thanks to a revision of the production process with an eye to ecology - has been able to reduce the consumption of raw materials and waste from processing by 20%. ABB SACE's commitment to safeguarding the environment is also shown in a concrete way by Life Cycle Assessments (LCA) of the products, carried out directly by ABB SACE's Research and Development in collaboration with the ABB Research Centre. Selection of materials, processes and packing materials is made optimising the true environmental impact of the product, also foreseeing the possibility of its being recycled.

Furthermore, in 1997 ABB SACE developed its Environmental Management system and got it certified in conformity with the international ISO14001 Standard, integrating it in 1999 with the Management System for Health and Safety in the workplace according to OHSAS 18001 (Swedish National Testing and Research Institute).



Index

Tmax circuit-breakers for power distribution

Electrical characteristics	2/4
General characteristics.....	2/6
Thermomagnetic trip units	2/8
Electronic trip units.....	2/11

Circuit-breaker for zone selectivity

Electrical characteristics	2/38
General characteristics.....	2/39
EFDP zone selectivity: PR223EF	2/40
ZS zone selectivity: PR332/P	2/43

Tmax circuit-breakers for motor protection

Electrical characteristics	2/46
General characteristics.....	2/48
Protection against short-circuit.....	2/49
Integrated protection: PR221MP.....	2/51
Integrated protection: PR222MP.....	2/52

Tmax circuit-breakers for use up to 1150 V AC and 1000 V DC

Electrical characteristics	2/60
----------------------------------	------

Switch-disconnectors

Electrical characteristics	2/64
----------------------------------	------

Power distribution





Circuit-breakers for power distribution



Index

Tmax circuit-breakers for power distribution

Electrical characteristics	2/4
General characteristics.....	2/6
Thermomagnetic trip units	2/8
Electronic trip units.....	2/11

Circuit-breakers for power distribution

Electrical characteristics

		Tmax T1 1P	Tmax T1			Tmax T2				
Rated uninterrupted current	[A]	160	160			160				
Poles	[No.]	1	3/4			3/4				
Rated service voltage, Ue	(AC) 50-60 Hz	240	690			690				
	(DC)	125	500			500				
Rated impulse withstand voltage, Uimp	[kV]	8	8			8				
Rated insulation voltage, Ui	[V]	500	800			800				
Test voltage at industrial frequency for 1 min.	[V]	3000	3000			3000				
Rated ultimate short-circuit breaking capacity, Icu	(AC) 50-60 Hz 220/230 V	B	B	C	N	N	S	H	L	
	(AC) 50-60 Hz 380/400/415 V	25*	25	40	50	65	85	100	120	
(AC) 50-60 Hz 440 V	[kA]	-	16	25	36	36	50	70	85	
(AC) 50-60 Hz 500 V	[kA]	-	10	15	22	30	45	55	75	
(AC) 50-60 Hz 690 V	[kA]	-	8	10	15	25	30	36	50	
(DC) 250 V - 2 poles in series	[kA]	-	3	4	6	6	7	8	10	
(DC) 250 V - 3 poles in series	[kA]	25 (at 125 V)	16	25	36	36	50	70	85	
(DC) 500 V - 2 poles in series	[kA]	-	20	30	40	40	55	85	100	
(DC) 500 V - 3 poles in series	[kA]	-	-	-	-	-	-	-	-	
(DC) 750 V - 3 poles in series	[kA]	-	16	25	36	36	50	70	85	
Rated service short-circuit breaking capacity, Ics										
(AC) 50-60 Hz 220/230 V	[%Icu]	75%	100%	75%	75%	100%	100%	100%	100%	
(AC) 50-60 Hz 380/400/415 V	[%Icu]	-	100%	100%	75%	100%	100%	100%	75% (70 kA)	
(AC) 50-60 Hz 440 V	[%Icu]	-	100%	75%	50%	100%	100%	100%	75%	
(AC) 50-60 Hz 500 V	[%Icu]	-	100%	75%	50%	100%	100%	100%	75%	
(AC) 50-60 Hz 690 V	[%Icu]	-	100%	75%	50%	100%	100%	100%	75%	
Rated short-circuit making capacity, Icm	(AC) 50-60 Hz 220/230 V	52.5	52.5	84	105	143	187	220	264	
	(AC) 50-60 Hz 380/400/415 V	-	32	52.5	75.6	75.6	105	154	187	
(AC) 50-60 Hz 440 V	[kA]	-	17	30	46.2	63	94.5	121	165	
(AC) 50-60 Hz 500 V	[kA]	-	13.6	17	30	52.5	63	75.6	105	
(AC) 50-60 Hz 690 V	[kA]	-	4.3	5.9	9.2	9.2	11.9	13.6	17	
Opening time (415 V)	[ms]	7	7	6	5	3	3	3	3	
Utilisation category (IEC 60947-2)		A	A			A				
Reference Standard		IEC 60947-2	IEC 60947-2			IEC 60947-2				
Isolation behaviour		■	■			■				
Trip units:	thermomagnetic									
	T fixed, M fixed	TMF	■	-	-	-	-	-	-	
	T adjustable, M fixed	TMD	-	■	-	-	■	-	-	
	T adjustable, M adjustable (5...10 x In)	TMA	-	-	-	-	-	-	-	
	T adjustable, M fixed (3 x In)	TMG	-	-	-	-	■ ^①	-	-	
	T adjustable, M adjustable (2.5...5 x In)	TMG	-	-	-	-	-	-	-	
	magnetic only	MA	-	-	-	-	■ (MF up to In 12.5 A)	-	-	
	electronic	PR221DS	-	-	-	-	-	■	-	-
		PR221GP/PR221MP	-	-	-	-	-	■	-	-
		PR222DS	-	-	-	-	-	-	-	-
		PR223DS	-	-	-	-	-	-	-	-
		PR231/P	-	-	-	-	-	-	-	-
		PR232/P	-	-	-	-	-	-	-	-
		PR331/P	-	-	-	-	-	-	-	-
		PR332/P	-	-	-	-	-	-	-	-
Interchangeability										
Versions		F	F			F-P				
Terminals	fixed	FC Cu	FC Cu-EF-FC CuAl-HR			F-FC Cu-FC CuAl-EF-ES-R				
	plug-in	-	-			F-FC Cu-FC CuAl-EF-ES-R				
	withdrawable	-	-			-				
Fixing on DIN rail		-	DIN EN 50022			DIN EN 50022				
Mechanical life	[No. operations]	25000	25000			25000				
	[No. Hourly operations]	240	240			240				
Electrical life @ 415 V AC	[No. operations]	8000	8000			8000				
	[No. Hourly operations]	120	120			120				
Basic dimensions - fixed version	3 poles	W [mm]	25.4 (1 pole)	76		90				
	4 poles	W [mm]	-	102		120				
		D [mm]	70	70			70			
	H [mm]	130	130			130				
Weight	fixed	3/4 poles [kg]	0.4 (1 pole)	0.9/1.2		1.1/1.5				
	plug-in	3/4 poles [kg]	-	-			1.5/1.9			
	withdrawable	3/4 poles [kg]	-	-			-			

TERMINAL CAPTION
 F = Front
 EF = Front extended
 ES = Front extended spread

FC Cu = Front for copper cables
 FC CuAl = Front for copper-aluminium cables
 R = Rear orientated
 HR = Rear flat horizontal

VR = Rear flat vertical
 HR/VR = Rear flat orientated
 MC = Multicable
 F = fixed circuit-breakers

P = plug-in circuit-breakers
 W = withdrawable circuit-breakers
^① The breaking capacity for settings In = 16 A and In = 20 A is 16 kA

Tmax T3		Tmax T4					Tmax T5					Tmax T6				Tmax T7			
250		250/320					400/630					630/800/1000				800/1000/1250/1600			
3/4		3/4					3/4					3/4				3/4			
690		690					690					690				690			
500		750					750					750				-			
8		8					8					8				8			
800		1000					1000					1000				1000			
3000		3500					3500					3500				3500			
N	S	N	S	H	L	V	N	S	H	L	V	N	S	H	L	S	H	L	V ⁽⁶⁾
50	85	70	85	100	200	200	70	85	100	200	200	70	85	100	200	85	100	200	200
36	50	36	50	70	120	200	36	50	70	120	200	36	50	70	100	50	70	120	150
25	40	30	40	65	100	180	30	40	65	100	180	30	45	50	80	50	65	100	130
20	30	25	30	50	85	150	25	30	50	85	150	25	35	50	65	40	50	85	100
5	8	20	25	40	70	80	20	25	40	70	80	20	22	25	30	30	42	50	60
36	50	36	50	70	100	150	36	50	70	100	150	36	50	70	100	-	-	-	-
40	55	-	-	-	-	-	-	-	-	-	-	-	-	-	-	-	-	-	-
-	-	25	36	50	70	100	25	36	50	70	100	20	35	50	65	-	-	-	-
36	50	-	-	-	-	-	-	-	-	-	-	-	-	-	-	-	-	-	-
-	-	16	25	36	50	70	16	25	36	50	70	16	20	36	50	-	-	-	-
75%	50%	100%	100%	100%	100%	100%	100%	100%	100%	100%	100%	100%	100%	100%	75%	100%	100%	100%	100%
75%	50% (27 kA)	100%	100%	100%	100%	100%	100%	100%	100%	100%	100%	100%	100%	100%	75%	100%	100%	100%	100%
75%	50%	100%	100%	100%	100%	100%	100%	100%	100%	100%	100%	100%	100%	100%	75%	100%	100%	100%	100%
75%	50%	100%	100%	100%	100%	100%	100%	100%	100%	100%	100%	100%	100%	100%	75%	100%	100%	75%	100%
75%	50%	100%	100%	100%	100%	100%	100%	100%	100%	100%	100%	75%	75%	75%	75%	100%	75%	75%	75%
105	187	154	187	220	440	660	154	187	220	440	660	154	187	220	440	187	220	440	440
75.6	105	75.6	105	154	264	440	75.6	105	154	264	440	75.6	105	154	220	105	154	264	330
52.5	84	63	84	143	220	396	63	84	143	220	396	63	94.5	105	176	105	143	220	286
40	63	52.5	63	105	187	330	52.5	63	105	187	330	52.5	73.5	105	143	84	105	187	220
7.7	13.6	40	52.5	84	154	176	40	52.5	84	154	176	40	46	52.5	63	63	88.2	105	132
7	6	5	5	5	5	5	6	6	6	6	6	10	9	8	7	15	10	8	8
A		A					B (400 A) ⁽³⁾ - A (630 A)					B (630A - 800A) ⁽³⁾ - A (1000A)				B ⁽⁷⁾			
IEC 60947-2		IEC 60947-2					IEC 60947-2					IEC 60947-2				IEC 60947-2			
■		■					■					■				■			
-		-					-					-				-			
■		■ (up to 50 A)					■ (up to 500 A)					■ (up to 800 A) ⁽⁴⁾				-			
-		■ (up to 250 A)					-				-	-				-			
■		-					■ (up to 500 A)					-				-			
-		■					-					-				-			
■		■					■					■				-			
-		-					-					-				-			
-		■					■					■				-			
-		■					■					■				-			
-		-					-					-				-			
-		-					-					-				-			
-		-					-					-				-			
-		■					■					■				■			
-		-					-					-				-			
F-P		F-P-W					F-P-W					F-W ⁽⁴⁾				F-W			
F-FC Cu-FC Cu Al-EF-ES-R		F-FC Cu-FC CuAl-EF-ES-R-MC					F-FC CuAl-EF-ES-R-RC					F-FC CuAl-EF-ES-R-RC				F-EF-ES-FC CuAl-HR-VR			
F-FC Cu-FC Cu Al-EF-ES-R		EF-ES-HR-VR-FC Cu-FC CuAl					EF-ES-HR-VR-FC Cu-FC CuAl					-				-			
-		EF-ES-HR-VR-FC Cu-FC CuAl					EF-ES-HR-VR-FC Cu-FC CuAl					EF-HR-VR				EF-HR-VR-RS-ES			
DIN EN 50022		-					-					-				-			
25000		20000					20000					20000				10000			
240		240					120					120				60			
8000		8000 (250 A) - 6000 (320 A)					7000 (400 A) - 5000 (630 A)					7000 (630A) - 5000 (800A) - 4000 (1000A)				2000 (S, H, L versions) / 3000 (V version)			
120		120					60					60				60			
105		105					140					210				210			
140		140					186					280				280			
70		103.5					103.5					103.5				154 (manual) / 178 (motorizable)			
150		205					205					268				268			
1.5/2		2.35/3.05					3.25/4.15					9.5/12				9.7/12.5 (manual) - 11/14 (motorizable)			
2.7/3.7		3.6/4.65					5.15/6.65					-				-			
-		3.85/4.9					5.4/6.9					12.1/15.1				29.7/39.6 (manual) - 32/42.6 (motorizable)			

⁽¹⁾ 75% for T5 630

⁽²⁾ 50% for T5 630

⁽³⁾ Icw = 5 kA

⁽⁴⁾ W version is not available on T6 1000 A

⁽⁵⁾ Icw = 7.6 kA (630 A) - 10 kA (800 A)

⁽⁶⁾ Only for T7 800/1000/1250 A

⁽⁷⁾ Icw = 20 kA (S,H,L versions) - 15 kA (V version)

⁽⁸⁾ For availability, please ask ABB SACE

Notes: In the plug-in version of T2, T3 and T5 630 and in the withdrawable version of T5 630 the maximum rated current available is derated by 10% at 40 °C

Circuit-breakers for power distribution

General characteristics

The series of Tmax moulded-case circuit-breakers - complying with the IEC 60947-2 Standard - is divided into seven basic sizes, with an application range from 1 A to 1600 A and breaking capacities from 16 kA to 200 kA (at 380/415 V AC).

For protection of alternating current networks, the following are available:

- T1B 1p circuit-breaker, equipped with TMF thermomagnetic trip units with fixed thermal and magnetic threshold ($I_3 = 10 \times I_n$);
- T1, T2, T3 and T4 (up to 50 A) circuit-breakers equipped with TMD thermomagnetic trip units with adjustable thermal threshold ($I_1 = 0.7 \dots 1 \times I_n$) and fixed magnetic threshold ($I_3 = 10 \times I_n$);
- T2, T3 and T5 circuit-breakers, fitted with TMG trip units for long cables and generator protection with adjustable thermal threshold ($I_1 = 0.7 \dots 1 \times I_n$) and fixed magnetic threshold ($I_3 = 3 \times I_n$) for T2 and T3 and adjustable magnetic threshold ($I_3 = 2.5 \dots 5 \times I_n$) for T5;
- T4, T5 and T6 circuit-breakers with TMA thermomagnetic trip units with adjustable thermal threshold ($I_1 = 0.7 \dots 1 \times I_n$) and adjustable magnetic threshold ($I_3 = 5 \dots 10 \times I_n$);
- T2 with PR221DS electronic trip unit;
- T4, T5 and T6 with PR221DS, PR222DS/P, PR222DS/PD and PR223DS electronic trip units;
- the T7 circuit-breaker, which completes the Tmax family up to 1600 A, fitted with PR231/P, PR232/P, PR331/P and PR332/P electronic trip units. The T7 circuit-breaker is available in the two versions: with manual operating mechanism or motorizable with stored energy operating mechanism⁽¹⁾.

The field of application in alternating current of the Tmax series varies from 1 A to 1600 A with voltages up to 690 V. The Tmax T1, T2, T3, T4, T5 and T6 circuit-breakers equipped with TMF, TMD and TMA thermomagnetic trip units can also be used in direct current plants, with a range of application from 1 A to 800 A and a minimum operating voltage of 24 V DC, according to the appropriate connection diagrams.

The three-pole T2, T3 and T4 circuit-breakers can also be fitted with MF and MA adjustable magnetic only trip units, both for applications in alternating current and in direct current, in particular for motor protection (see page 2/45 and following).

For all the circuit-breakers in the series, fitted with thermomagnetic and electronic trip units, the single-phase trip current is defined (see page 4/57).

⁽¹⁾ For motorisation, the T7 circuit-breaker with stored energy operating mechanism must be ordered, complete with geared motor for automatic spring charging, opening coil and closing coil.

Interchangeability

The Tmax T4, T5 and T6 circuit-breakers can be equipped either with TMF, TMD, TMG or TMA thermomagnetic trip units, MA magnetic only trip units or PR221DS, PR222DS/P, PR222DS/PD, PR222MP and PR223DS electronic trip units.

Similarly, Tmax T7 can also mount the latest generation PR231/P, PR232/P, PR331/P⁽¹⁾ and PR332/P⁽¹⁾ electronic trip units.

Trip units

Circuit-breakers	TMD			TMA								TMG					
	20	32	50	80	100	125	160	200	250	320	400	500	630	800	320	400	500
In [A]																	
T4 250	■	■	■	■	■	■	■	■	■								
T4 320	▲	▲	▲	▲	▲	▲	▲	▲	▲								
T5 400										■	■				▲	▲	
T5 630										▲	▲	■			▲	▲	▲
T6 630													■				
T6 800														■			
T6 1000																	
T7 800																	
T7 1000																	
T7 1250																	
T7 1600																	

■ = Complete circuit-breaker already coded ⁽¹⁾ If ordered loose PR331/P and PR332/P must be completed with the "trip unit adapters" (see page 3/42)
▲ = Circuit-breaker to be assembled

Range of application of the circuit-breakers in alternating current and in direct current

AC	Trip unit	Range [A]
T1 1p 160	TMF	16...160
T1 160	TMD	16...160
T2 160	TMD	1.6...160
	TMG	16...160
	MF/MA	1...100
	PR221DS	10...160
	PR221GP	63...160
	PR221MP	40...100
T3 250	TMG	63...250
	TMD	63...250
	MA	100...200
T4 250/320	TMD	20...50
	TMA	80...250
	MA	10...200
	PR221DS	100...320
	PR222DS/P-PR222DS/PD	100...320
	PR223DS	160...320
T5 400/630	TMG	320...500
	TMA	320...500
	PR221DS	320...630
	PR222DS/P-PR222DS/PD	320...630
	PR223DS	320...630
	TMA	630...800
T6 630/800/1000	PR221DS	630...1000
	PR222DS/P-PR222DS/PD	630...1000
	PR223DS	630...1000
	TMA	630...1000
T7 800/1000/1250/1600	PR231/P-PR232/P	400...1600
	PR331/P-PR332/P	400...1600
DC		
T1 1p 160	TMF	16...160
T1 160	TMD	16...160
T2 160	TMD	1.6...160
T3 250	MF/MA	1...100
	TMD/TMG	63...250
T4 250/320	MA	100...200
	TMD	20...50
	TMA	80...250
T5 400/630	MA	10...200
	TMA/TMG	320...500
T6 630/800/1000	TMA	630...800

MF = magnetic only trip unit with fixed magnetic thresholds
 MA = magnetic only trip unit with adjustable magnetic thresholds
 TMF = thermomagnetic trip unit with fixed thermal and magnetic thresholds
 TMD = thermomagnetic trip unit with adjustable thermal and fixed magnetic thresholds
 TMA = thermomagnetic trip unit with adjustable thermal and magnetic thresholds
 TMG = thermomagnetic trip unit for generator protection
 PR22_, PR23_, PR33_ = electronic trip units

Thanks to their simplicity of assembly, the end customer can change the type of trip unit extremely rapidly, according to their own requirements and needs: in this case, correct assembly is the customer's responsibility. Above all, this means into increased flexibility of use of the circuit-breakers with considerable savings in terms of costs thanks to better rationalisation of stock management.

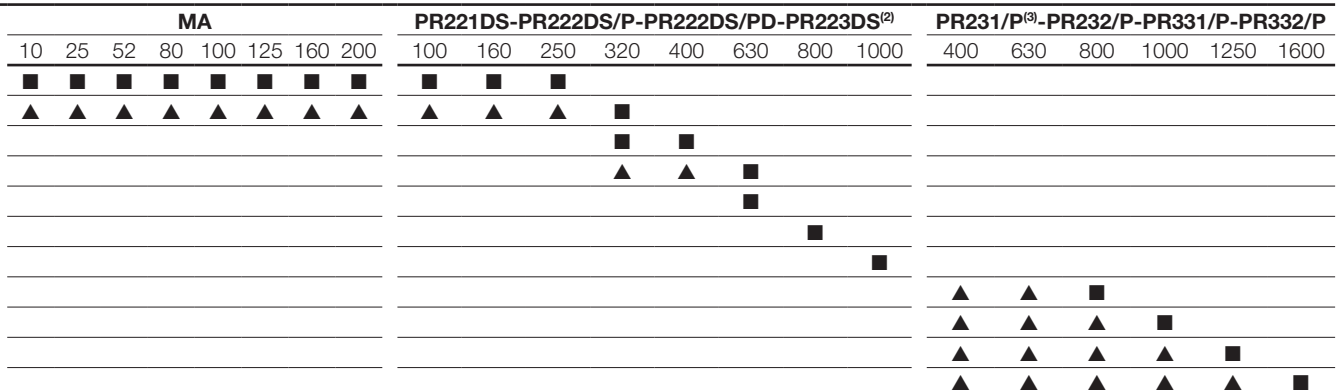

⁽²⁾ PR223DS, minimum In = 160 A.

⁽³⁾ Interchangeability of PR231/P can be requested by means of the dedicated ordering code 1SDA063140R1.

Circuit-breakers for power distribution

Thermomagnetic trip units

The Tmax T1 1p, T1, T2, T3, T4, T5 and T6 circuit-breakers can be fitted with thermomagnetic trip units and are used in protection of alternating and direct current networks with a range of use from 1.6 A to 800 A. They allow the protection against overload with a thermal device (with fixed threshold for T1 1p and adjustable threshold for T1, T2, T3, T4, T5 and T6) realised using the bimetal technique, and protection against short-circuit with a magnetic device (with fixed threshold for T1, T2 and T3 and T4 up to 50 A and adjustable threshold for T4, T5 and T6).

The four-pole circuit-breakers are always supplied with the neutral protected by the trip unit and with protection of the neutral at 100% of the phase setting for settings up to 100 A. For higher settings, the protection of the neutral is at 50% of the phase setting unless the protection of the neutral at 100% of the phase setting is required.

Thermomagnetic trip units TMD e TMG (for T1, T2 and T3)

Thermal threshold
Adjustable from 0.7 to 1 x I_n

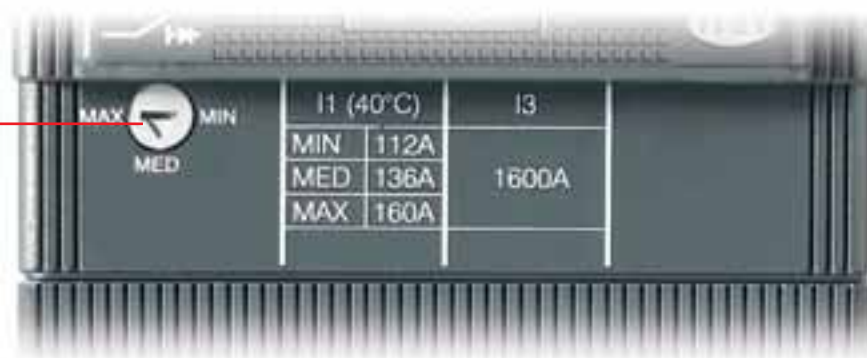

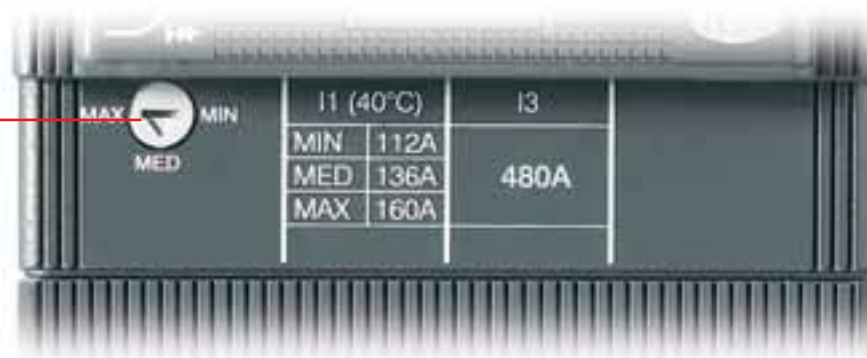

Thermal threshold
Adjustable from 0.7 to 1 x I_n





TMD = thermomagnetic trip unit with adjustable thermal threshold ($I_1 = 0.7 \dots 1 \times I_n$) and fixed magnetic threshold ($I_3 = 10 \times I_n$).
TMG = thermomagnetic trip unit with adjustable thermal threshold ($I_1 = 0.7 \dots 1 \times I_n$) and fixed magnetic threshold ($I_3 = 3 \times I_n$).

Furthermore, for Tmax T2, T3 and T5, the TMG thermomagnetic trip units with low magnetic trip threshold are available. For T2 and T3 the trip unit has adjustable thermal threshold ($I_1 = 0.7 \dots 1 \times I_n$) and fixed magnetic threshold ($I_3 = 3 \times I_n$), whereas for T5 the trip unit has adjustable thermal threshold ($I_1 = 0.7 \dots 1 \times I_n$) and adjustable magnetic threshold ($I_3 = 2.5 \dots 5 \times I_n$). The thermomagnetic trip units can be used to protect long cables and for generator protection, both in direct current and in alternating current.



TMD - T1 and T3

	I_n [A]	16 ⁽¹⁾	20 ⁽¹⁾	25 ⁽²⁾	32	40	50	63	80	100	125	125	160	200	250
	Neutral [A] - 100%	16	20	25	32	40	50	63	80	100	125	-	160	200	250
$I_1 = 0.7 \dots 1 \times I_n$	Neutral [A] - 50%	-	-	-	-	-	-	-	-	-	-	80	100	125	160
T1 160		■	■	■	■	■	■	■	■	■	■	-	■	-	-
T3 250								■	■	■	■	■	■	■	■
	I_3 [A]	630 ⁽³⁾	630 ⁽³⁾	630 ⁽³⁾	630 ⁽³⁾	630 ⁽³⁾	630 ⁽³⁾	630	800	1000	1250	1250	1600	2000	2500
	Neutral [A] - 100%	630	630	630	630	630	630	630	800	1000	1250	1250	1600	2000	2500
$I_3 = 10 \times I_n$	Neutral [A] - 50%	-	-	-	-	-	-	-	-	-	-	800	1000	1250	1600



TMD - T2

	I_n [A]	1.6	2	2.5	3.2	4	5	6.3	8	10	12.5	16	20	25	32	40	50	63	80	100	125	160
	Neutral [A] - 100%	1.6	2	2.5	3.2	4	5	6.3	8	10	12.5	16	20	25	32	40	50	63	80	100	125	160
$I_1 = 0.7 \dots 1 \times I_n$	Neutral [A] - 50%	-	-	-	-	-	-	-	-	-	-	-	-	-	-	-	-	-	-	-	80	100
	I_3 [A]	16	20	25	32	40	50	63	80	100	125	500	500	500	500	500	500	630	800	1000	1250	1600
	Neutral [A] - 100%	16	20	25	32	40	50	63	80	100	125	500	500	500	500	500	500	630	800	1000	1250	1600
$I_3 = 10 \times I_n$	Neutral [A] - 50%	-	-	-	-	-	-	-	-	-	-	-	-	-	-	-	-	-	-	-	800	1000

TMG - T2

	I_n [A]	25	40	63	80	100	125	160
	Neutral [A] - 100%	25	40	63	80	100	125	160
$I_1 = 0.7 \dots 1 \times I_n$								
	I_3 [A]	160	200	200	240	300	375	480
	Neutral [A] - 100%	160	200	200	240	300	375	480
$I_3 = 3 \times I_n$								

TMG - T3

	I_n [A]	63	80	100	125	160	200	250
	Neutral [A] - 100%	63	80	100	125	160	200	250
$I_1 = 0.7 \dots 1 \times I_n$								
	I_3 [A]	400	400	400	400	480	600	750
	Neutral [A] - 100%	400	400	400	400	480	600	750
$I_3 = 3 \times I_n$								

Notes: ⁽¹⁾ only T1B ⁽²⁾ only T1B and T1C ⁽³⁾ T1N $\Rightarrow I_3$ [A] = 500; T1B-C available also the version with $\Rightarrow I_3$ [A] = 500
 - I_n identifies the setting current for protection of the phases (L1, L2 and L3) and of the neutral.
 - The TMD and TMA thermomagnetic trip units have the thermal element with adjustable threshold $I_1 = 0.7 \dots 1 \times I_n$. The value of the thermal element adjustment which is obtained by acting on the special selector, is intended at 40 °C. The magnetic element has fixed trip threshold with $\pm 20\%$ tolerance according to what is indicated by the IEC 60947-2 (pos. 8.3.3.1.2) Standard. The trip thresholds of the magnetic protection I_3 are a function of the setting used both by the phase and neutral protection.

Circuit-breakers for power distribution

Thermomagnetic trip units

Thermomagnetic trip units TMD/TMA and TMG (for T4, T5 and T6)

Thermal threshold

Adjustable

Thermal threshold



Adjustable from 0.7 to 1 x I_n





1SDC21005AF0001

TMA = thermomagnetic trip unit with adjustable thermal threshold ($I_t = 0.7...1 \times I_n$) and adjustable magnetic threshold ($I_s = 5...10 \times I_n$)
 TMG (for T5) = thermomagnetic trip unit with adjustable thermal threshold ($I_t = 0.7...1 \times I_n$) and adjustable magnetic threshold ($I_s = 2.5...5 \times I_n$)



TMD/TMA - T4

 $I_t = 0.7...1 \times I_n$	In [A]	20	32	50	80	100	125	160	200	250
	Neutral [A] - 100%	20	32	50	80	100	125	160	200	250
	Neutral [A] - 50%	-	-	-	-	-	80	100	125	160
 $I_s = 10 \times I_n$ $I_s = 5...10 \times I_n$	$I_s = 10 \times I_n$	320	320	500						
	Neutral [A] - 100%	320	320	500	400...800	500...1000	625...1250	800...1600	1000...2000	1250...2500
	Neutral [A] - 50%	-	-	-	-	-	400...800	500...1000	625...1250	800...1600



TMA - T5

 $I_t = 0.7...1 \times I_n$	In [A]		320		400		500
	Neutral [A] - 100%		320		400		500
	Neutral [A] - 50%		200		250		320
 $I_s = 5...10 \times I_n$	I_s [A]		1600...3200		2000...4000		2500...5000
	Neutral [A] - 100%		1600...3200		2000...4000		2500...5000
	Neutral [A] - 50%		1000...2000		1250...2500		1600...3200

TMG - T5

 $I_t = 0.7...1 \times I_n$	In [A]		320		400		500
	Neutral [A] - 100%		320		400		500
	Neutral [A] - 50%						
 $I_s = 2.5...5 \times I_n$	I_s [A]		800...1600		1000...2000		1250...2500
	Neutral [A] - 100%		800...1600		1000...2000		1250...2500
	Neutral [A] - 50%						

TMA - T6

 $I_t = 0.7...1 \times I_n$	In [A]		630		800
	Neutral [A] - 100%		630		800
	Neutral [A] - 50%		400		500
 $I_s = 5...10 \times I_n$	I_s [A]		3150...6300		4000...8000
	Neutral [A] - 100%		3150...6300		4000...8000
	Neutral [A] - 50%		2000...4000		2500...5000

- Notes**
- In identifies the setting current for protection of the phases (L1, L2 and L3) and of the neutral.
 - The TMA and TMG thermomagnetic trip units which equip the Tmax T4, T5 and T6 circuit-breakers have the thermal element with adjustable threshold $I_t = 0.7...1 \times I_n$. The set current value which is obtained using the special selector is intended at 40 °C. The magnetic element has adjustable trip threshold ($I_s = 5...10 \times I_n$ for TMA and $I_s = 2.5...5 \times I_n$ for TMG) with a tolerance of $\pm 20\%$ according to what is indicated in the IEC 60947-2 (par. 8.3.3.1.2) Standard. The trip thresholds of the magnetic protection I_s are a function of the setting used both by the phase and neutral protection.

Circuit-breakers for power distribution

Electronic trip units

The Tmax T2, T4, T5, T6 and T7 circuit-breakers, for use in alternating current, can be equipped with overcurrent releases constructed using electronic technology. This allows protection functions to be obtained which guarantee high reliability, tripping precision and insensitivity to temperature and to the electromagnetic components in conformity with the standards on the matter.

The power supply needed for correct operation is supplied directly by the current sensors of the release, and tripping is always guaranteed, even under single-phase load conditions and in correspondence with the minimum setting.

Characteristics of the Tmax electronic trip units

Operating temperature	-25 °C ... +70 °C
Relative humidity	98%
Self-supply	0.2 x In (single phase)
Auxiliary power supply (where applicable)	24 V DC
Operating frequency	45...66 Hz
Electromagnetic compatibility (LF and HF)	IEC 60947-2 Annex F

For Tmax T2, T4, T5 and T6 the protection trip unit consists of:

- 3 or 4 current sensors (current transformers)
- external current sensors (e.g. for the external neutral), when available
- a trip unit
- a trip coil (for T2 housed in the right slot, for T4, T5 and T6 integrated in the electronic trip unit).

For Tmax T7 the protection trip unit consists of:

- 3 or 4 current sensors (Rogowski coils and current transformers)
- external current sensors (e.g. for the external neutral)
- interchangeable rating plug
- a trip unit
- a trip coil housed in the body of the circuit-breaker.

Rating plugs

Circuit-breaker	CS Rated current	In [A]					
		400	630	800	1000	1250	1600
T7	800	■	■	■			
	1000	■	■	■	■		
	1250	■	■	■	■	■	
	1600	■	■	■	■	■	■

The current sensors supply the electronic trip unit with the energy needed for correct operation of the trip unit and the signal needed to detect the current.

The current sensors are available with rated primary current as shown in the table.

Current sensors

	In [A]	10	25	63	100	160	250	320	400	630	800	1000	1250	1600
PR221DS	T2	■	■	■	■	■								
	T4				■	■	■	■						
	T5							■	■	■				
	T6									■	■	■		
PR222DS/P, PR222DS/PD, PR223DS ⁽¹⁾	T4				■	■	■	■						
	T5							■	■	■				
	T6									■	■	■		
PR231/P, PR232/P, PR331/P, PR332/P	T7								■	■	■	■	■	■

⁽¹⁾ For PR223DS, the minimum rated current is In=160 A.

When a protection function trips, the circuit-breaker opens by means of the trip coil, which changes over a contact (AUX-SA, supplied on request, see chapter "Accessories" at page 3/20 and following) to signal trip unit tripped. Signalling reset is of mechanical type and takes place with resetting of the circuit-breaker.

Circuit-breakers for power distribution

Electronic trip units

Basic protection functions



(L) Protection against overload

This protection function trips when there is an overload with inverse long-time delay trip according to the IEC 60947-2 Standard ($I^2t=k$). The protection cannot be excluded.



(S) Protection against short-circuit with time delay

This protection function trips when there is a short-circuit, with long inverse time-delay trip ($I^2t=k$ ON) or a constant trip time ($I^2t=k$ OFF). The protection can be excluded.



(I) Instantaneous protection against short-circuit

This protection function trips instantaneously in case of a short-circuit. The protection can be excluded.



(G) Protection against earth fault

The protection against earth fault trips when the vectorial sum of the currents passing through the current sensors exceeds the set threshold value, with long inverse time-delay trip ($I^2t=k$ ON) or a constant trip time ($I^2t=k$ OFF). The protection can be excluded.

Advanced protection functions

The PR332/P trip unit makes it possible to carry out highly developed protection against the most varied types of fault. In fact, it adds the following advanced protection functions to the basic protection functions.



IEC 60255-3

(L) Protection against overload (IEC 60255-3)

This protection trips in case of an overload with inverse long-time delay according to IEC 60255-3 Standard, for the coordination with fuses and MV protections. The protection can be excluded.



(U) Protection against unbalanced phase

The protection function against unbalanced phase U can be used in those cases where a particularly precise control is needed regarding missing and/or unbalance of the phase currents. The trip time is instantaneous. The protection can be excluded.



(OT) Protection against overtemperature

The protection against overtemperature trips instantaneously when the temperature inside the trip unit exceeds 85 °C, in order to prevent any temporary or continual malfunction of the microprocessor. The protection cannot be excluded.



(Rc) Protection against residual current ⁽¹⁾

This integrated protection is based on current measurements made by an external toroid and is alternative to protection against earth fault G. The protection can be excluded.



(ZS) Zone selectivity ⁽²⁾

ZS zone selectivity is an advanced method for carrying out coordination of the protections in order to reduce the trip times of the protection closest to the fault in relation to the time foreseen by time selectivity. Zone selectivity can be applied to the protection functions S and G, with constant time-delay trip. The protection can be excluded.



(UV, OV, RV) Protections against voltage

The three protections trip with a constant time-delay in the case of undervoltage, overvoltage and residual voltage respectively. The latter allows to detect interruptions of the neutral (or of the earthing conductor in systems with earthed neutral) and faults which cause movement of the star centre in systems with isolated neutral (e.g. large earth faults) to be identified. Movement of the star centre is calculated by vectorially summing the phase voltages. The protections can be excluded.



(RP) Protection against reversal of power

The protection against reversal power causes tripping of the breaker, with constant time-delay trip, when the flow of power reverses sign and exceeds, as an absolute value, the set threshold. It is particularly suitable for protection of large machines such as generators. The protection can be excluded.





(UF, OF) Protections of frequency

The two protections detect the variation in network frequency above or below the adjustable thresholds, opening the circuit-breaker, with constant time-delay trip. The protection can be excluded.

⁽¹⁾ It is not suitable for human protection.

⁽²⁾ For further information about zone selectivity, please see the section: "Circuit-breakers for zone selectivity".

Electronic trip units for power distribution

SACE PR221DS			
	PR221DS	PR221DS	PR221GP
Protection functions	L S / I	I	L S I

SACE PR222DS/P			
	PR222DS/P	PR222DS/P	
Protection functions	L S I	L S I G	

SACE PR222DS/PD			
	PR222DS/PD	PR222DS/PD	
Protection functions	L S I	L S I G	

SACE PR223DS			
	PR223DS		
Protection functions	L S I G		

Circuit-breakers for power distribution

Electronic trip units

2

SACE PR231/P		
	PR231/P	PR231/P
Protection functions	L S / I	I

SACE PR232/P		
	PR232/P	
Protection functions	L S I	

SACE PR331/P		
	PR331/P	
Protection functions	L S I G	

SACE PR332/P				
	PR332/P	PR332/P	PR332/P	PR332/P
Protection functions	L I	L S I	L S I G ⁽¹⁾	L S I Rg
Advanced protection function ⁽²⁾	L U OT	L U OT	L U OT	L U OT
Opt. ⁽³⁾	UV OV RV RP UF OF	UV OV RV RP UF OF	UV OV RV RP UF OF	UV OV RV RP UF OF
⁽¹⁾ In alternative to Rc (with external toroid).	⁽²⁾ Available with PR330/V. Measurement module.			
⁽³⁾ For all versions.	⁽³⁾ According to IEC 60255-3.			

PR221DS

The PR221DS trip unit, available for T2, T4, T5 and T6, provides protection functions against overload L and short-circuit S/I (version PR221DS-LS/I): with this version, by moving the dedicated dip-switch, you can choose whether to have inverse time-delay S or instantaneous I protection against short-circuit. Alternatively, the version with only the protection function against instantaneous short-circuit I is available (version PR221DS-I, also see page 2/45 and following).

There is a single adjustment for the phases and the neutral. However, for the neutral it can be decided whether to request the protection threshold of the functions at 50 - 100% of that of the phases for Tmax T2 In = 160 A (T2 In < 160 A, N = 100%), whereas for T4, T5 and T6 it is possible to select the protection threshold OFF, 50% or 100% directly from the front of the trip unit by means of the specific dip switch.

The trip coil is always supplied with the PR221DS trip unit for Tmax T2 and is housed in the right-hand slot of the circuit-breaker. Dedicated auxiliary contacts are available for T2 with electronic trip unit (see page 3/22).

For Tmax T4, T5 and T6, the opening solenoid is housed internally and therefore, by not using the right-hand slot of the circuit-breaker, all the auxiliary contacts available can be used.

PR221DS-LS/I

Protection S
Against short-circuit with delayed trip

Protection L
Against overload





Dip-switch for neutral setting (only for T4, T5 and T6)

Socket for TT1 test unit

Protection I
Against short-circuit with instantaneous trip

1SDC210B05F0001

PR221DS - Protection functions and parameterisations

Protection functions ⁽¹⁾	Trip threshold	Trip curves	Excludability	Relation t = f(I)
 <p>Against overload with long inverse time delay trip and trip characteristic according to an inverse time curve (I²t=k) according to IEC 60947-2 Standard</p>	$I_1 = 0.40 - 1 \times I_n$ step = 0.04 x I _n Trip between 1.1...1.30 x I ₁ (T4, T5, T6) Trip between 1.05...1.30 x I ₁ (T2)	at 6 x I ₁ t ₁ = 3-6 (only for T2) - 12s (only for T4, T5, T6) Tolerance: ± 10% up to 6 x I _n (T4, T5, T6) ± 10% up to 2 x I _n (T2) ± 20% above 6 x I _n (T4, T5, T6) ± 20% above 2 x I _n (T2)	-	t = k/I ²
 <p>Against short-circuit with inverse short time delay trip and trip characteristic with inverse time (I²t=k) (selectable as an alternative to protection function I)</p>	$I_2 = 1-1.5-2-2.5-3-3.5-4.5-5.5-6.5-7-7.5-8-8.5-9-10 \times I_n^{(2)}$ Tolerance: ± 10% (T4, T5, T6) ± 10% up to 2 x I _n (T2) ± 20% above 2 x I _n (T2)	at 8 x I _n t ₂ = 0.1 - 0.25s Tolerance: ± 10% up to 6 x I _n (T4, T5, T6) ± 20% above 6 x I _n (T4, T5, T6) ± 20% (T2)	■	t = k/I ²
 <p>Against short-circuit with instantaneous trip (selectable as an alternative to protection function S)</p>	$I_3 = 1-1.5-2-2.5-3-3.5-4.5-5.5-6.5-7-7.5-8-8.5-9-10 \times I_n^{(2)}$ Tolerance: ± 10% (T4, T5, T6) ± 20% (T2)	instantaneous	■	t = k

⁽¹⁾ These tolerances hold in the following conditions:
 - self-powered trip unit at full power (without start-up)
 - two or three-phase power supply
 In conditions other than those considered, the following tolerances hold:

⁽²⁾ For T4 In = 320 A, T5 In = 630 A and T6 In = 1000 A ⇒ I_{2,max} = 9.5 x I_n, I_{3,max} = 9.5 x I_n.
 The setting at 10 x I_n corresponds to 9.5 x I_n.

	Trip threshold	Trip time
S	± 20%	± 20%
I	± 20%	≤ 40ms

Circuit-breakers for power distribution

Electronic trip units

PR221GP

The PR221GP electronic release, only available on Tmax T2, is specific for protection of generators with the following rated currents: $I_n = 63 \text{ A}$, $I_n = 100 \text{ A}$, $I_n = 160 \text{ A}$.

It allows wide adjustment of the protection against overload L , $I_1 = 0.4 \dots 1 \times I_n$ and above all provides the possibility of selecting four trip curves.

Generator protection typically requires low trip thresholds with regard to protection against short-circuit. Thanks to the PR221GP protection with time delay adjustable up to 2.5 times the rated current, $I_2 = 1 \dots 2.5 \times I_n$ is guaranteed, with the possibility of selecting between two trip curves.

It is also possible to set an instantaneous protection against short-circuit (I) fixed at 4 times the trip threshold of the protection against delayed short-circuit (S).

The S and I protection functions are not alternative to each other.

As for Tmax T2 PR221DS, it is necessary to house the opening solenoid (SA) in the right-hand slot of the circuit-breaker. Tmax T2 PR221GP can be fitted with the same electrical accessories available with PR221DS.

The functions present on this release allow the requirements imposed by the major naval registers, such as LLRRS, ABS and RINA to be satisfied.

PR221GP

Protection S
Against short-circuit
with delayed trip

Protection L
Against overload



Socket for TT1
test unit

Protection I
Against short-circuit
with instantaneous trip

1SDC210B59F0001

PR221GP – Protection and parameterisation functions

Protection function ⁽¹⁾	Trip threshold	Trip curves	Excludability	Relation $t = f(I)$
L Against overload with long inverse time delay trip and trip characteristic according to an inverse time curve ($I^2t = \text{constant}$) according to IEC 60947-2 Standard	$I_1 = 0.40 - 1 \times I_n$ step = $0.04 \times I_n$	at $6 \times I_1$ $t_1 = 0.7 - 1.4 - 2.8 - 5.5 \text{ s}$ Tolerance: $\pm 10\%$ up to $2 \times I_n$ $\pm 20\%$ over $2 \times I_n$	-	-
S Against short-circuit with inverse short time delay trip and trip characteristic with inverse time ($I^2t = \text{constant}$)	$I_2 = 1 \dots 2.5 \times I_n$ step = $0.5 \times I_n$ Tolerance: $\pm 10\%$	at $5 \times I_n$ $t_2 = 0.07 - 0.175 \text{ s}$ Tolerance: $\pm 10\%$ up to $2 \times I_n$	-	$t = k/I$
I Against short-circuit with instantaneous trip with adjustable threshold	$I_3 = 4 \times I_2$ fixed Tolerance: $\pm 20\%$	instantaneous	■	$t = k$

⁽¹⁾ The tolerances are valid with these hypotheses:
 – self-supplied release at full power and/or auxiliary power supply (without start up)
 – two-phase or three-phase power supply
 For all the cases not foreseen in the above hypotheses, the following tolerance values are valid:

	Trip threshold	Trip time
S	$\pm 20\%$	$\pm 20\%$
I	$\pm 20\%$	$\leq 40\text{ms}$

PR222DS/P

The PR222DS/P trip unit, available for T4, T5 and T6, has protection functions against overload L, delayed S and instantaneous I short-circuit (version PR222DS/P-LSI). Alternatively, as well as the functions L, S, I, it also has protection against earth fault G (version PR222DS/P-LSIG).

Setting of the PR222DS trip unit can be carried out by means of dip switches on the front of the circuit-breaker or electronically, using the PR010/T programming and control unit (see page 3/46) or the BT030 wireless communication unit (see page 3/42).

There is a single setting for the phases and neutral, for which one can decide whether to set the threshold of the protection functions to OFF, to 50% or to 100% that of the phases by means of two dedicated dip switches.

Furthermore, on the front of the PR222DS/P (or PR222DS/PD) trip units, signalling of pre-alarm and alarm of protection L is available. The pre-alarm threshold value, signalled by the red LED fixed, is equal to $0.9 \times I_1$. It is also possible to transmit remotely the alarm of protection L, simply connecting connector X3 to the dedicated contact.

PR222DS/PD

Apart from the protection functions available for the PR222DS/P trip unit (for the settings see page 2/20), the PR222DS/PD trip unit, available for T4, T5 and T6 also has the dialogue unit integrated with Modbus® RTU protocol.

The Modbus® RTU protocol has been known and used worldwide for many years and is now a market standard thanks to its simplicity of installation, configuration and to its integration in the various different supervision, control and automation systems, as well as good level performances.

The PR222DS/PD trip units allow the Tmax T4, T5 and T6 circuit-breakers to be integrated in a communication network based on the Modbus® RTU protocol. Modbus® RTU provides a Master-Slave system architecture where a Master (PLC, PC...) cyclically interrogates several Slaves (field devices). The devices use the EIA RS485 standard as the physical means for data transmission at a maximum transmission speed of 19.2 kbps.

Again for this trip unit, the power supply needed for correct operation of the protection functions is supplied directly by the current transformers of the trip unit, and tripping is always guaranteed, even under conditions of single-phase load down. Nevertheless, communication is only possible with an auxiliary power supply of 24 V DC.

PR222DS/PD - Electrical characteristics

Auxiliary power supply (galvanically insulated)	24 V DC \pm 20%
Maximum ripple	\pm 5%
Inrush current @ 24 V	1 A for 30 ms
Rated current @ 24 V	100 mA
Rated power @ 24 V	2.5 W

The PR222DS/PD release, with integrated communication and control functions, allows a wide range of information to be acquired and transmitted remotely, opening and closing commands to be carried out by means of the electronic version motor operator, the configuration and programming parameters of the unit to be stored, such as the current thresholds of the protection functions and the protection curves.

All the information can be consulted both locally, directly on the front of the circuit-breaker with the front display unit FDU or on the HMI030 switchgear multi-meter, and remotely by means of supervision and control systems.

Moreover, by means of the BT030 external module, to be connected to the test connector of the PR222DS/PD trip unit, wireless communication to a PDA or Notebook is possible through a Bluetooth port.

The PR222DS/PD trip units can be associated with the AUX-E auxiliary contacts in electronic version, to know the state of the circuit-breaker (open/closed), and with MOE-E motor operator (the AUX-E are compulsory when MOE-E is to be used) to remotely control circuit-breaker opening and closing as well.

If the circuit-breaker fitted with the PR222DS/PD trip unit is inserted in a supervision system, during the test phases with the PR010/T unit, communication is automatically abandoned and starts again on completion of this operation.

Circuit-breakers for power distribution

Electronic trip units

	PR22DS/P	PR22DS/PD	PR223DS
Communication functions			
Protocol		Modbus RTU standard	Modbus RTU standard
Physical medium		EIA RS485	EIA RS485
Speed (maximum)		19.2 kbps	19.2 kbps
Measurement functions			
Phase currents	■ ⁽¹⁾	■	■
Neutral current	■ ⁽¹⁾	■	■
Ground current	■ ⁽¹⁾	■	■
Voltages (phase to phase, phase to earth)			■ ⁽⁶⁾
Powers (active, reactive, apparent)			■ ⁽⁶⁾
Power factors			■ ⁽⁶⁾
Energies			■ ⁽⁶⁾
Peak factor			■
Frequency			■ ⁽⁶⁾
Signalling functions			
L pre-alarm and alarm LED	■ ⁽⁵⁾	■ ⁽⁵⁾	■
L alarm output contact ⁽²⁾	■	■	■
Available data			
Circuit-breaker status (open, closed) ⁽³⁾		■	■
Mode (local, remote)		■	■
Protection parameters set	■ ⁽¹⁾	■	■
Alarms			
Protections: L, S, I, G	■ ⁽¹⁾	■	■
Failed tripping under fault conditions	■ ⁽¹⁾	■	■
Maintenance			
Total number of operations		■	■
Total number of trips		■	■
Number of trip tests		■	■
Number of manual operations		■	■
Number of trips for each individual protection function		■	■
Record of last trip data	■ ⁽¹⁾	■	■
Commands			
Circuit-breaker opening/closing (with motor operator)		■	■
Alarm reset	■ ⁽¹⁾	■	■
Circuit-breaker reset (with motor operator)		■	■
Setting the curves and protection thresholds	■ ⁽¹⁾	■	■
Safety function			
Automatic opening in the case of failed Trip command fail (with motor operator) ⁽⁴⁾		■	■
Events			
Changes in circuit-breaker state, in the protections and all the alarms		■	■

⁽¹⁾ With PR010/T unit or BT030 unit

⁽²⁾ Typical contact: MOS photo Vmax: 48 V DC/30 V AC
Rmax = 35 ohm

⁽³⁾ Available with AUX-E electronic auxiliary contacts

⁽⁴⁾ The motor operator must be in electronic version (MOE-E) and electronic auxiliary contacts (AUX-E) have to be used

⁽⁵⁾ Signals: - Pre-alarm L - permanently lit
- Alarm L - flashing (0.5 s ON / 0.5 s OFF)
- Incongruent manual setting (L > S / S > I) - flashing (1 s ON / 2 s OFF)
- WINK (remote control to identify the relay) - flashing (0.125 s ON / 0.125 s OFF)

⁽⁶⁾ With VM210

PR222DS/P

Protection S
Against short-circuit with delayed trip

Protection L
Against overload

Socket for TT1 test unit

Socket for connection of PR10/T test unit and BT030 wireless communication unit

Protection I
Against short-circuit with instantaneous trip

Dip-switch for neutral setting

Selection for electronic or manual setting

1SDC210B06F0001

PR222DS/PD

Protection S
Against short-circuit with delayed trip

Protection L
Against overload

Socket for TT1 test unit

Socket for connection of PR10/T test unit and BT030 wireless communication unit

Protection I
Against short-circuit with instantaneous trip

Dip-switch for neutral setting

Enablement of remote operations

Selection for electronic or manual setting

1SDC210B07F0001

PR223DS

Socket for connection of PR10/T test unit and BT030 wireless communication unit

Socket for TT1 test unit

LED signalling alarm of the circuit-breaker

LED signalling the status of the circuit-breaker





Push button for operation mode selection (local/remote) and on-board diagnosis system

1SDC210B08F0001

Circuit-breakers for power distribution

Electronic trip units

PR222DS/P, PR222DS/PD and PR223DS⁽⁵⁾ - Protection functions and parameterisations

Protection functions	Trip threshold	Trip curves ⁽¹⁾	Excludability	Relation $t = f(I)$
 Against overload with long inverse time delay trip and trip characteristic according to an inverse time curve ($I^2t = k$) according to IEC 60947-2 Standard	Manual setting $I_1 = 0.40 \dots 1 \times I_n$ step = $0.02 \times I_n$	Manual setting at $6 \times I_1$ $t_1 = 3 - 6 - 9 - 18s^{(2)}$	-	$t = k/I^2$
 Against short-circuit with inverse short time delay trip and trip characteristic with inverse time ($I^2t = k$) or definite time	Manual setting $I_2 = 0.6 - 1.2 - 1.8 - 2.4 - 3 - 3.6 - 4.2 - 5.8 - 6.4 - 7 - 7.6 - 8.2 - 8.8 - 9.4 - 10 \times I_n^{(3)}$	Manual setting at $8 \times I_n$ $t_2 = 0.05 - 0.1 - 0.25 - 0.5s$	■	$t = k/I^2$
	Electronic setting $I_2 = 0.60 \dots 10 \times I_n$ step $0.1 \times I_n$ Tolerance: $\pm 10\%$	Electronic setting at $8 \times I_n$ $t_2 = 0.05 \dots 0.5s$ step $0.01s$ Tolerance: $\pm 10\%$ ⁽⁴⁾	■	$t = k$
Manual setting $I_2 = 0.6 - 1.2 - 1.8 - 2.4 - 3 - 3.6 - 4.2 - 5.8 - 6.4 - 7 - 7.6 - 8.2 - 8.8 - 9.4 - 10 \times I_n^{(3)}$	Manual setting $t_2 = 0.05 - 0.1 - 0.25 - 0.5s$			
 Against short-circuit with instantaneous trip	Manual setting $I_3 = 1.5 - 2.5 - 3 - 4 - 4.5 - 5 - 5.5 - 6.5 - 7 - 7.5 - 8 - 9 - 9.5 - 10.5 - 12 \times I_n^{(3)}$	instantaneous	■	$t = k$
	Electronic setting $I_3 = 1.5 \dots 12 \times I_n^{(3)}$ step $0.1 \times I_n$ Tolerance: $\pm 10\%$			
 Against earth fault with inverse short time delay trip and trip characteristic according to an inverse time curve ($I^2t = k$)	Manual setting $I_4 = 0.2 - 0.25 - 0.45 - 0.55 - 0.75 - 0.8 - 1 \times I_n$	Manual setting up to $3.15 \times I_4$ up to $2.25 \times I_4$ up to $1.6 \times I_4$ up to $1.10 \times I_4$ $t_4 = 0.1s$ $t_4 = 0.2s$ $t_4 = 0.4s$ $t_4 = 0.80s$	■	$t = k/I^2$ ⁽⁶⁾
	Electronic setting $I_4 = 0.2 \dots 1 \times I_n$ step $0.1 \times I_n$ Tolerance: $\pm 10\%$	Electronic setting $t_4 = 0.1 \dots 0.8s$ step $0.01s$ Tolerance: $\pm 15\%$		

⁽¹⁾ These tolerances hold in the following conditions:
 - self-powered trip unit at full power and/or auxiliary supply
 - two or three-phase power supply
 In conditions other than those considered, the following tolerances hold:

	Trip threshold	Trip time
S	$\pm 20\%$	$\pm 20\%$
I	$\pm 20\%$	$\leq 50ms$
G	$\pm 20\%$	$\pm 20\%$

⁽²⁾ For T4 $I_n = 320 A$, T5 $I_n = 630 A$ and T6 $I_n = 1000 A \Rightarrow t_1 = 10.5s$

⁽³⁾ For T4 $I_n = 320 A$ and T5 $I_n = 630 A$. T6 $I_n = 1000 A \Rightarrow I_{2max} = 9.5 \times I_n$ and $I_{3max} = 9.5 \times I_n$
 For T6 $I_n = 800 A \Rightarrow I_{3max} = 10.5 \times I_n$

⁽⁴⁾ Tolerance: $\pm 10 ms$

⁽⁵⁾ The setting of the PR223DS trip unit is electronic only (local/remote)

The L protection can be set at $I_1 = 0.18 \dots 1 \times I_n$. For $I_1 < 0.4 \times I_n$ the neutral setting must be at 100% of that of the phases

⁽⁶⁾ $t = k/I^2$ up to the current value indicated, $t = k$ (equating to the chosen setting) beyond the current value indicated

PR223DS

Apart from the traditional L, S, I, and G protection functions, the PR223DS release, available on T4, T5 and T6, also offers the possibility of measuring the main electrical values. In fact, using the accessory VM210, and without using any voltage transformers, the user has access not only to the current values but also to the voltage, power and energy values, both locally, directly on the front of the circuit-breaker with the front display unit FDU, or on the interface for the front of the switchboard HMI030, and remotely via a supervisor and control system.

Setting the PR223DS release can only be carried out electronically, using the PR010/T test unit (setting in local mode) or the dialogue (setting in remote mode). For the protection function adjustments, see page 2/20.

For the neutral, it is possible to set the protection threshold of the functions to OFF, to 50% and to 100% of that of the phases (for protection L settings below $0.4 \times I_n$, it is obligatory to set the neutral to 100%). The pre-alarm and alarm signalling of protection L are also available by means of a dedicated LED on the front of the release. The pre-alarm threshold value is equal to $0.9 \times I_1$.

Still on the front of the release, the LEDs signalling the following information are available: state of the connection to the opening solenoid, use of the default parameters, mode (local or remote), presence of auxiliary power supply and setting the neutral.

PR223DS - Measurements

Measurements	With distributed N	Without distributed N
Effective current values	I_1, I_2, I_3, I_{ne}	I_1, I_2, I_3
Effective voltage values	$V_{11}, V_{22}, V_{33}, V_{12}, V_{23}, V_{31}$	V_{12}, V_{23}, V_{31}
Apparent powers	S_{tot}, S_1, S_2, S_3	S_{tot}
Active powers	P_{tot}, P_1, P_2, P_3	P_{tot}
Reactive powers	Q_{tot}, Q_1, Q_2, Q_3	Q_{tot}
Power factors	$\cos \varphi$	$\cos \varphi$
Energies	E_{TOT}	E_{TOT}
Phase peak factor	■	■
Frequency	f	f

The PR223DS trip unit, with integrated ModBus RTU protocol based dialogue unit, allows a wide range of information to be acquired and transmitted remotely and to carry out opening and closing commands.

The PR223DS trip unit can be associated with the AUX-E auxiliary contacts, to know the state of the circuit-breaker (open, closed), and with MOE-E motor operator (the AUX-E are compulsory when MOE-E is to be used) to remotely control circuit-breaker opening and closing as well.

If the PR223DS trip unit is inserted in a supervision system, during the test and configuration with the PR010/T unit, communication is automatically abandoned and starts again on completion of these operations.

The unit is self-supplied by means of current sensors housed in the electronic release. Operation of the electronic release is also guaranteed when there is a single-phase load and in correspondence with the minimum setting. An external power supply must be connected to activate the dialogue function and the measurement functions.

Auxiliary power supply - Electrical characteristics

	PR223DS
Auxiliary power supply (galvanically insulated)	24 V DC \pm 20%
Maximum ripple	\pm 5%
Inrush current @ 24 V	~ 4 A for 0.5 ms
Rated current @ 24 V	~ 80 mA
Rated power @ 24 V	~ 2 W

Circuit-breakers for power distribution

Electronic trip units

PR231/P

The PR231/P trip unit is the basic trip unit for Tmax T7. It provides protection functions against overload L and short-circuit S/I (version PR231/P-LS/I): with this version, by moving the dedicated dip-switch, you can choose whether to have protection S or protection I. Alternatively the version with only the protection function against instantaneous short-circuit I is available (version PR231/P-I see also page 2/45 and following).

Setting the trip parameters of the PR231/P trip unit is made directly on the front of the circuit-breaker by means of dip switches, and there is only one for the phases and the neutral, so it is possible to set the protection threshold, at 50% or at 100% of the phase protection.

To guarantee protection of the installation by means of the PR231/P protection trip unit, it is necessary to select the rated network frequency (50/60 Hz), by means of the special dip-switch.

Interchangeability of PR231/P can be requested by means of the dedicated ordering code 1SDA063140R1.

PR231/P

Protection L

Against overload

Socket for TT1 test unit

Rating Plug

Dip-switch for network frequency



Protection S



Against short-circuit with delayed trip

Dip-switch for neutral setting

Protection I

Against short-circuit with instantaneous trip

PR231/P - Protection functions and parameterisations

Protection functions	Trip threshold	Trip curves ⁽¹⁾	Excludability	Relation $t = f(I)$
 <p>Against overload with long inverse time delay trip and trip characteristic according to an inverse time curve ($I^2t = k$) according to IEC 60947-2 Standard</p>	$I_1 = 0.40 \dots 1 \times I_n$ step = $0.04 \times I_n$ Trip between $1.1 \dots 1.3 \times I_1$	at $6 \times I_1$ at $6 \times I_1$ $t_1 = 3 - 12s$ Tolerance: $\pm 10\%$	—	$t = k/I^2$
 <p>Against short-circuit with long inverse time delay trip and trip characteristic with inverse time ($I^2t = k$) (selectable as an alternative to protection function I)</p>	$I_2 = 1-1.5-2-2.5-3-3.5-4.5-5.5-6.5-7-7.5-8-8.5-9-10 \times I_n$ Tolerance: $\pm 10\%$	at $10 \times I_n$ at $10 \times I_n$ $t_2 = 0.1 - 0.25s$ Tolerance: $\pm 10\%$	■	$t = k/I^2$
 <p>Against short-circuit with instantaneous trip (selectable as an alternative to protection function S)</p>	$I_3 = 1-1.5-2-2.5-3-3.5-4.5-5.5-6.5-7-7.5-8-8.5-9-10 \times I_n$ Tolerance: $\pm 10\%$	instantaneous	—	$t = k$

⁽¹⁾ These tolerances hold in the following conditions:
 – self-powered trip unit at full power
 – two or three-phase power supply
 In conditions other than those considered, the following tolerances hold:

	Trip threshold	Trip time
S	$\pm 10\%$	$\pm 20\%$
I	$\pm 15\%$	$\leq 60ms$



PR232/P

The PR232/P release, available for T7, provides protection functions against overload L, delayed short-circuit S and instantaneous short-circuit I (version PR232/P-LSI).

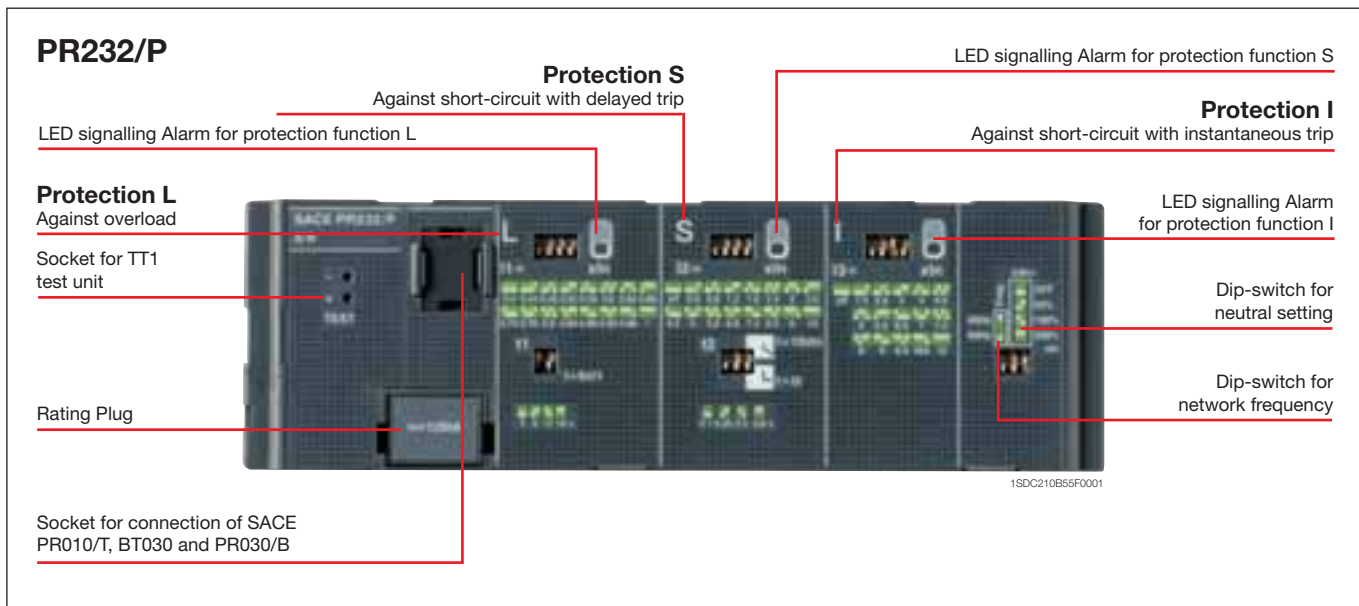
Setting the trip parameters (see table) of the PR232/P release can be carried out by means of the dip-switches, and is unique for the phases and the neutral, for which it is possible to set the protection threshold to OFF, to 50%, 100% or 200% of the threshold of the phases directly from the front of the release by means of a special dip-switch. In particular, adjustment of the neutral to 200% of the phase current requires setting protection L to respect the current-carrying capacity of the circuit-breaker. To guarantee protection of the installation by means of the PR232/P protection release, it is necessary to select the rated network frequency (50/60 Hz), by means of the special dip-switch.



PR232/P - Protection functions and parameterisations

Protection functions	Trip threshold	Trip curves ⁽¹⁾	Thermal memory ⁽²⁾	Excludability	Relation $t = f(I)$
 <p>Against overload with long inverse time delay trip and trip characteristic according to an inverse time curve ($I^2t = k$) according to IEC 60947-2 Standard</p>	$I_1 = 0.40 \dots 1 \times I_n$ step = $0.04 \times I_n$ Trip between $1.1 \dots 1.3 \times I_1$	at $6 \times I_1$ $t_1 = 3s$ $t_1 = 6s$ $t_1 = 12s$ $t_1 = 18s$ Tolerance: $\pm 10\%$	■	-	$t = k/I^2$
 <p>Against short-circuit with inverse short time delay trip and trip characteristic with inverse time ($I^2t = k$) or definite time</p>	$I_2 = 0.6 - 0.8 - 1.2 - 1.8 - 2.4 - 3 - 3.6 - 4.2 - 5 - 5.8 - 6.6 - 7.4 - 8.2 - 9 - 10 \times I_n$ Tolerance: $\pm 10\%$	at $10 \times I_n$ $t_2 = 0.1s$ $t_2 = 0.25s$ $t_2 = 0.5s$ $t_2 = 0.8s$ Tolerance: $\pm 10\%$	■	■	$t = k/I^2$
 <p>Against short-circuit with instantaneous trip</p>	$I_3 = 1.5 - 2.5 - 3 - 4 - 4.5 - 5 - 5.5 - 6.5 - 7 - 7.5 - 8 - 9 - 9.5 - 10.5 - 12 \times I_n$ Tolerance: $\pm 10\%$	$I > I_2$ $t_2 = 0.1s$ $t_2 = 0.25s$ $t_2 = 0.5s$ $t_2 = 0.8s$ Tolerance: $\pm 10\%$	-	■	$t = k$

⁽¹⁾ These tolerances hold in the following conditions:
 - self-powered trip unit at full power (without start-up)
 - two or three-phase power supply
 In conditions other than those considered, the following tolerances hold:

	Trip threshold	Trip time
S	$\pm 10\%$	$\pm 20\%$
I	$\pm 15\%$	$\leq 60ms$

⁽²⁾ Active up to 7 min. after tripping of the breaker (ON/OFF setting by means of PR010/T test unit).

Circuit-breakers for power distribution

Electronic trip units

There are three red LEDs available on the front of the PR232/P trip unit dedicated to signalling alarm of protections L, S, and I. Furthermore, a yellow flashing LED allows the state of pre-alarm of function L to be signalled, which is activated when 90% of the set trip threshold is reached. The yellow flashing LED every 3s indicates the normal operation.

PR232/P - Alarm and Pre-alarm LED

Protection	Colour	Pre-alarm	Alarm	Last trip
	Yellow	■	-	-
	Red	-	■	■
	Red	-	■	■
	Red	-	■	■

Following circuit-breaker opening, it is possible to know which protection function made the release trip by connecting the PR030/B battery unit onto the front of the release. This is also possible thanks to the PR010/T test and configuration unit.

By means of the BT030 wireless communication unit the PR232/P can be connected to a PDA or to a personal computer, extending the range of information available for the user. In fact, by means of the ABB SACE's SD-Pocket communication software, it is possible to read the values of the currents flowing through the circuit-breaker, the value of the last 20 interrupted currents, and the protection settings.

PR331/P

The PR331/P, available for Tmax T7 in the PR331/P-LSIG version, with its complete range of protection functions together with the wide combination of thresholds and trip times offered is it suitable for protecting a wide range of alternating current installations. In addition to protection functions the unit is provided with multifunction LED indicators. Furthermore, PR331/P allows connection to external devices enhancing its advanced characteristics like remote signalling and monitoring, or interface from front of HMI030 panel.

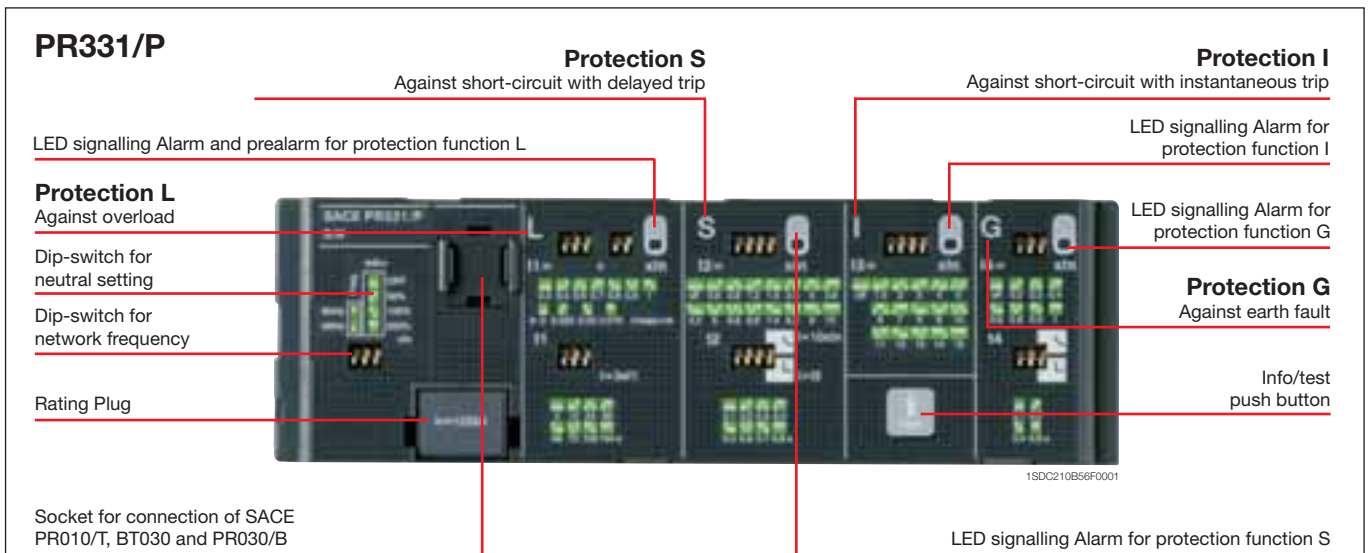

PR331/P - Protection functions and parameterisations

Protection functions	Trip threshold	Trip curves ⁽¹⁾	Excludability	Relation $t = f(I)$
L Against overload with long inverse time-delay trip and trip characteristic according to an inverse time curve ($I^2t=k$) according to the IEC 60947-2 Standard	$I_1 = 0.40 \dots 1 \times I_n$ step = 0.025 $\times I_n$ Trip between 1.05 ... 1.2 $\times I_1$	at 3 $\times I_1$ $t_1 = 3 - 12 - 24 - 36 - 48 - 72 - 108 - 144s$ Tolerance: $\pm 10\%$ up to 6 $\times I_n$ $\pm 20\%$ above 6 $\times I_n$	—	$t = k/I^2$
S Against short-circuit with short inverse time-delay trip and trip characteristic with inverse time ($I^2t=k$) or with definite time	$I_2 = 0.6 - 0.8 - 1.2 - 1.8 - 2.4 - 3 - 3.6 - 4.2 - 5 - 5.8 - 6.6 - 7.4 - 8.2 - 9 - 10 \times I_n$ Tolerance: $\pm 7\%$ up to 6 $\times I_n$ $\pm 10\%$ above 6 $\times I_n$	at 10 $\times I_n$ $t_2 = 0.1 \dots 0.8s$ step = 0.1s Tolerance: min ($\pm 10\%$, $\pm 40ms$)	■	$t = k/I^2$
I Against short-circuit with adjustable instantaneous trip	$I_3 = 1.5-2-3-4-5-6-7-8-9-10-11-12-13-14-15 \times I_n^{(2)}$ Tolerance: $\pm 10\%$	$I > I_3$ $t_3 = 0.1 \dots 0.8s$ step = 0.1s Tolerance: $\pm 15\%$ up to 6 $\times I_n$ $\pm 20\%$ above 6 $\times I_n$	■	$t = k$
G Against earth fault with short inverse time-delay trip and trip characteristic according to an inverse time curve ($I^2t=k$) or with definite time	$I_4 = 0.2-0.3-0.4-0.6-0.8-0.9-1 \times I_n$ Tolerance: $\pm 7\%$	$4.47 \times I_4$ $3.16 \times I_4$ $2.24 \times I_4$ $1.58 \times I_4$ $t_4 = 0.1s$ $t_4 = 0.2s$ $t_4 = 0.4s$ $t_4 = 0.80s$ Tolerance: $\pm 15\%$	■	$t = k/I^2$ ⁽³⁾
	$I_4 = 0.2-0.3-0.4-0.6-0.8-0.9-1 \times I_n$ Tolerance: $\pm 7\%$	$t_4 = 0.1s$ $t_4 = 0.2s$ $t_4 = 0.4s$ $t_4 = 0.80s$ Tolerance: min ($\pm 10\%$, $\pm 40ms$)	■	$t = k$

⁽¹⁾ These tolerances hold in the following conditions:
 – self-powered trip unit at full power and/or auxiliary supply
 – two or three-phase power supply
 In conditions other than those considered, the following tolerances hold:

	Trip threshold	Trip time
L	Release between 1.05 and 1.25 $\times I_1$	$\pm 20\%$
S	$\pm 10\%$	$\pm 20\%$
I	$\pm 15\%$	$\leq 60ms$
G	$\pm 15\%$	$\pm 20\%$

⁽²⁾ For T7 $I_n = 1250 A/1600 A \Rightarrow I_{n,max} = 12 \times I_n$
⁽³⁾ $t = k/I^2$ up to the current value indicated, $t = k$ equating to the chosen setting) beyond the current value indicated

Circuit-breakers for power distribution

Electronic trip units

User interface

The user communicates directly with the trip unit by means of the dip switches. Up to four LEDs (according to the version) are also available for signalling. These LEDs (one for each protection) are active when:

- a protection is timing. For protection L the pre-alarm status is also shown;
- a protection has tripped (the corresponding LED is activated by pressing the "Info/Test" pushbutton);
- a failure in connection of a current sensor or in the trip coil is detected. The indication is active when the unit is powered (through current sensors or an auxiliary power supply);
- wrong rating plug for the circuit-breaker.

The protection tripped indication works even with the circuit-breaker open, without the need for any internal or external auxiliary power supply. This information is available for 48 hours of inactivity after the trip and is still available after reclosing. If the query is made more than 48 hours later it is sufficient to connect a PR030/B battery unit, PR010/T, or a BT030 wireless communication unit.

Setting the neutral

Protection of the neutral can be set at 50%, 100% or 200% of the phase currents. In particular, adjustment of the neutral at 200% of the phase current is possible if the following inequality is respected: $I_1 \times I_n \times \%N_e \leq I_u$. The user can also switch the neutral protection OFF.

Test function

The Test function is carried out by means of the Info/Test pushbutton and the PR030/B battery unit (or BT030) fitted with a polarized connector housed on the bottom of the box, which allows the device to be connected to the test connector on the front of PR331/P trip units. The PR331/P electronic trip unit can be tested by using the SACE PR010/T test and configuration unit by connecting it to the TEST connector.

Power supply

The unit does not require an external power supply either for protection functions or for alarm signalling functions. It is self-supplied by means of the current sensors installed on the circuit-breaker. For operation, it is required for the three phases to be passed through by a current of 70 A. An external power supply can be connected in order to activate additional features, and in particular for connection to external devices: HMI030 and PR021/K.

PR331/P - Electrical characteristics

Auxiliary power supply (galvanically insulated)	24 V DC \pm 20%
Maximum ripple	5%
Inrush current @ 24 V	3 A for 5 ms
Rated power @ 24 V	1 W

Communication

By means of the BT030 wireless communication unit, PR331/P can be connected to a PDA or to a personal computer, extending the range of information available for the user. In fact, by means of ABB SACE's SD-Pocket communication software, it is possible to read the values of the currents flowing through the circuit-breaker, the value of the last 20 interrupted currents, and the protection settings.

PR331/P can also be connected to the optional external PR021/K signalling unit, for the remote signalling of protections alarms and trips, and to HMI030, for the remote user interfacing.

PR332/P

The SACE PR332/P trip unit for Tmax T7 (available in four versions: PR332/P-LI, PR332/P-LSI, PR332/P-LSIG and PR332/P-LSIRc) is a sophisticated and flexible protection system based on a state-of-the-art microprocessor and DSP technology. Fitted with the optional internal PR330/D-M dialogue unit, PR332/P turns into an intelligent protection, measurement and communication device, based on the Modbus® RTU protocol. By means of the PR330/D-M, PR332/P can also be connected to the ABB EP010 Fieldbus plug adapter, which makes it possible to choose among several different networks, such as Profibus and DeviceNet.



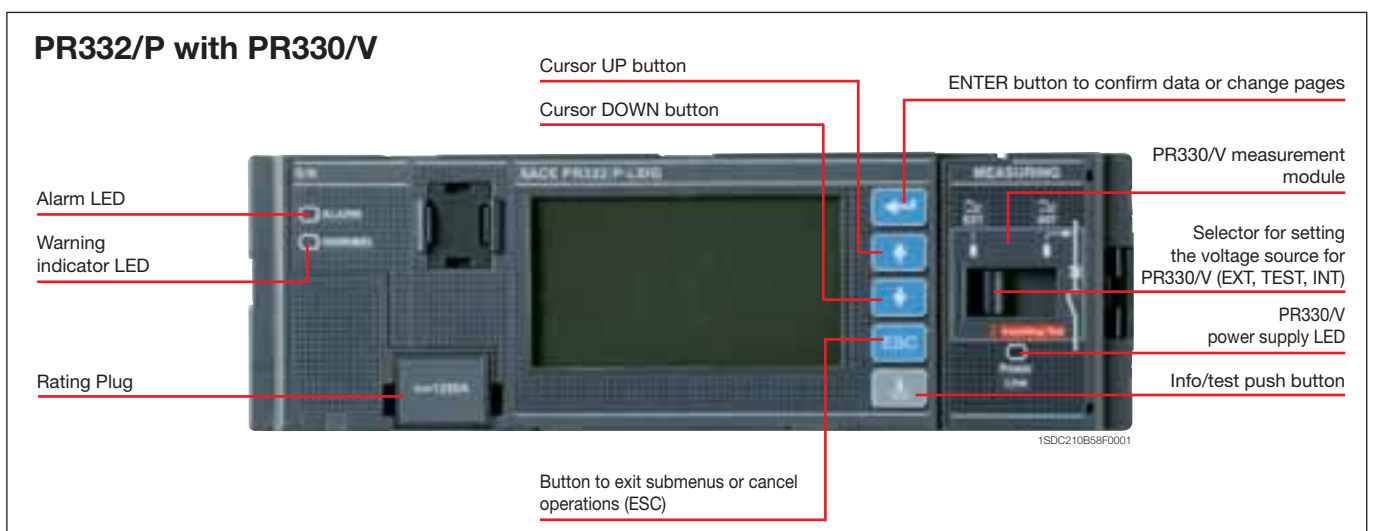



The new PR332/P is the result of ABB SACE's experience in designing protection trip units. The exhaustive range of settings makes this protection unit ideal for general use in power distribution. Access to information and programming using a keyboard and graphic liquid crystal display is extremely simple and intuitive. An integrated ammeter and many other additional features are provided over and above the protection functions. These additional functions can be further increased with addition on board of the dialogue, signalling, measurement, and wireless communication units. All the thresholds and trip curve delays of the protection functions are stored in special memories which retain the information even when no power is supplied.









Circuit-breakers for power distribution

Electronic trip units

PR332/P - Protection functions and parameterisations

Protection functions	Trip threshold	Trip curves ⁽¹⁾	Excludability	Relation $t = f(I)$	Thermal memory ⁽²⁾	Zone selectivity ⁽²⁾
 Against overload with inverse long-time delay trip according to IEC 60947-2 Standard ($I^2t=k$) or in accordance with the IEC 60255-3 Standard ($t=f(\alpha)^{(3)}$)	$I_1 = 0.4...1 \times I_n$ step = $0.01 \times I_n$ Trip between $1.05...1.2 \times I_1$	at $3 \times I_1$ $t_2 = 3...144s$ step = 3s Tolerance: $\pm 10\%$ up to $6 \times I_n$ $\pm 20\%$ above $6 \times I_n$	-	$t = k/I^2$	■	-
 Against short-circuit with short inverse time-delay trip and trip characteristic with inverse time ($I^2t=k$) or with definite time	$I_2 = 0.6...10 \times I_n$ step = $0.1 \times I_n$ Tolerance: $\pm 7\%$ up to $6 \times I_n$ $\pm 10\%$ above $6 \times I_n$	at $10 \times I_n$ $t_2 = 0.05...0.8s$ step = $0.01s$ Tolerance: $\pm 15\%$ up to $6 \times I_n$ $\pm 20\%$ over $6 \times I_n$	■	$t = k/I^2$	■	-
 Against short-circuit with adjustable instantaneous trip	$I_3 = 0.6...10 \times I_n$ step = $0.1 \times I_n$ Tolerance: $\pm 7\%$ up to $6 \times I_n$ $\pm 10\%$ above $6 \times I_n$	$t_2 = 0.05...0.8s$ step = $0.01s$ $t_{2\text{ sel}} = 0.04...0.2s$ step = $0.01s$ Tolerance: min ($\pm 10\%$; $\pm 40ms$)	■	$t = k$	-	■
 Against earth fault with short inverse time-delay trip and trip characteristic according to an inverse time curve ($I^2t=k$) or with definite time	$I_4 = 0.2...1 \times I_n$ step = $0.02 \times I_n$ Tolerance: $\pm 7\%$	$t_4 = 0.1...1s$ step = $0.05s$ Tolerance: $\pm 15\%$	■	$t = k/I^{(2)}$ ⁽³⁾	-	-
 Against residual current fault with definite time-delay trip	$I_{\Delta} = 3-5-7-10-20-30 A$ Tolerance: 0-20%	$t_{\Delta} = 0.06-0.1-0.2-0.3-0.4-0.5-0.8s$ Tolerance: $\pm 20\%$	■	$t = k$	-	-
 Against overtemperature of the trip unit with instantaneous trip	Trip unit temperature over $85^\circ C$	instantaneous	-	temp = k	-	-
 Against unbalanced phase with definite time-delay trip	$I_6 = 2\%...90\% \times I_1$ step = $1\% \times I_1$ Tolerance: $\pm 10\%$	$t_6 = 0.5...60s$ step = $0.5s$ Tolerance: min ($\pm 20\%$; $\pm 100ms$)	■	$t = k$	-	-

PR332/P with PR330/V - Advanced protection functions and parameterisations

Advanced protection functions	Trip threshold	Trip curves ⁽¹⁾	Excludability	Relation $t = f(I)$	Thermal memory ⁽²⁾	Zone selectivity
 Against undervoltage with adjustable constant time	$U_8 = 0.5...0.95 \times U_n$ step = $0.01 \times U_n$ Tolerance: $\pm 5\%$	$t_8 = 0.1...5s$ step = $0.1s$ Tolerance: min ($\pm 20\%$; $\pm 100ms$)	■	$t = k$	-	-
 Against overvoltage with adjustable constant time	$U_9 = 1.05...1.2 \times U_n$ step = $0.01 \times U_n$ Tolerance: $\pm 5\%$	$t_9 = 0.1...5s$ step = $0.1s$ Tolerance: min ($\pm 20\%$; $\pm 100ms$)	■	$t = k$	-	-
 Against residual voltage with adjustable constant time	$U_{10} = 0.1...0.4 \times U_n$ step = $0.01 \times U_n$ Tolerance: $\pm 5\%$	$t_{10} = 0.5...30s$ step = $0.5s$ Tolerance: min ($\pm 10\%$; $\pm 100ms$)	■	$t = k$	-	-
 Against reversal of power with adjustable constant time	$P_{11} = -0.3...-0.1 \times P_n$ step = $0.02 \times P_n$ Tolerance: $\pm 10\%$	$t_{11} = 0.5...25s$ step = $0.1s$ Tolerance: min ($\pm 10\%$; $\pm 100ms$)	■	$t = k$	-	-
 Against underfrequency with adjustable constant time	$f_{12} = 0.90...0.99 \times f_n$ step = $0.01 \times f_n$ Tolerance: $\pm 5\%$	$t_{12} = 0.5...3s$ step = $0.1s$ Tolerance: min ($\pm 10\%$; $\pm 100ms$)	■	$t = k$	-	-
 Against overfrequency with adjustable constant time	$f_{13} = 1.01...1.10 \times f_n$ step = $0.01 \times f_n$ Tolerance: $\pm 5\%$	$t_{13} = 0.5...3s$ step = $0.1s$ Tolerance: min ($\pm 10\%$; $\pm 100ms$)	■	$t = k$	-	-

⁽¹⁾ These tolerances are valid under the following conditions:
- trip unit self-supplied at full power and/or auxiliary supply
- two or three-phase power supply

In conditions other than those considered, the following tolerances hold:

	Trip threshold	Trip time
L	Release between 1.05 and $1.25 \times I_1$	$\pm 20\%$
S	$\pm 10\%$	$\pm 20\%$
I	$\pm 15\%$	$\leq 60ms$
G	$\pm 15\%$	$\pm 20\%$
Other	$\pm 10\%$	$\pm 20\%$

⁽²⁾ Active with 24V auxiliary power supply

⁽³⁾ $t = \frac{(3^\alpha - 1)}{I_1^\alpha} t_1 (3 \times I_1)$

⁽⁴⁾ For $T7 I_n = 1250 A/1600 A \Rightarrow I_{3\text{max}} = 12 \times I_n$

⁽⁵⁾ $k = (2s) \cdot (I_1)^2$

Setting the neutral

In PR332/P, the neutral protection is 50% of the value set for phase protection in the standard version. The neutral protection can be excluded or set to 100%.

In installations where very high harmonics occur, the resulting current at the neutral can be higher than that of the phases. Therefore it is possible to set the neutral protection at 150% or 200% of the value set for the phases. In this case it is necessary to reduce the setting of protection L accordingly. The table below lists the neutral settings for the various possible combinations between type of circuit-breaker and the threshold I_1 setting.

Adjustable neutral protection settings

Threshold I_1 settings (overload protection)

Circuit-breaker model	$0.4 < I_1 < 0.5$	$0.5 < I_1 < 0.66$	$0.66 < I_1 < 1^{(1)}$
T7	0-50-100-150-200%	0-50-100-150%	0-50-100%

⁽¹⁾ The setting $I_1 = 1$ indicates the maximum overload protection setting. The actual maximum setting allowable must take into account any derating based on temperature, the terminals used and the altitude (see the "Installations" chapter)

Start-up function

The start-up function allows protections S, I and G to operate with higher trip thresholds during the start-up phase. This avoids untimely tripping caused by the high inrush currents of certain loads (motors, transformers, lamps).

The start-up phase lasts from 100 ms to 30 s, in steps of 0.01 s. It is automatically recognized by the PR332/P trip unit when the peak value of the maximum current exceeds the threshold that can be set by the user. A new start-up becomes possible after the current has fallen down to $0.1 \times I_n$, if the trip unit is supplied from an external source.

Protection against overtemperature

The user has the following signals or commands available for the protection against overtemperature:

- lighting up of the "Warning" LED when the temperature is higher than 70 °C or lower than -20 °C (temperature at which the microprocessor is still able to operate correctly);
- lighting up of the "Alarm" LED when the temperature is higher than 85 °C or lower than -25 °C (temperature above which the microprocessor can no longer guarantee correct operation) and, when decided during the unit configuration stage, simultaneous opening of the circuit-breaker with indication of the trip directly on the display, as for the other protections.

Self-diagnosis

The PR332/P range of trip units contains an electronic circuit which periodically checks the continuity of internal connections (trip coil and each current sensor, including the Source Ground Return when present).

In the case of a malfunction an alarm message appears directly on the display. The Alarm is highlighted by the Alarm LED as well.

Residual Current

Different solutions are available for integrated residual current protection. The basic choice is PR332/P-LSIRc, which has all the characteristics of PR332/P-LSI and residual current protection as well. When additional features are required, the solution is PR332/P-LSIG with an additional PR330/V module (see next paragraph). Using this configuration, residual current protection is added to a powerful unit, having the features of PR332/P-LSI and all the add-ons described for the PR330/V module, such as voltage protection and advanced measurement functions.

Residual current protection acts by measuring the current by means the external dedicated toroid.

Circuit-breakers for power distribution

Electronic trip units

Test Functions

Once enabled from the menu, the “Info/Test” pushbutton on the front of the trip unit allows correct operation of the chain consisting of the microprocessor, trip coil and circuit-breaker tripping mechanism to be checked.

The control menu also includes the option of testing correct operation of the display, signalling LEDs.

By means of the front multi-pin connector it is possible to apply a SACE PR010/T Test unit which allows the functions of the PR222DS/P, PR222DS/PD, PR223DS, PR223EF, PR232/P, PR331/P and PR332/P ranges of trip units to be tested and checked.

User interface

The human-machine interface (HMI) of the device is made up of a wide graphic display, LEDs, and browsing pushbuttons. The interface is designed to provide maximum simplicity.

The language can be selected from among five available options: Italian, English, German, French and Spanish.

As in the previous generation of trip units, a password system is used to manage the “Read” or “Edit” modes. The default password, 0001, can be modified by the user.

The protection parameters (curves and trip thresholds) can be set directly via the HMI of the device. The parameters can only be changed when the trip unit is operating in “Edit” mode, but the information available and the parameter settings can be checked at any time in “Read” mode.

When a communication device (internal PR330/D-M module or external BT030 device) is connected, it is possible to set parameters simply by downloading them into the unit (over the network for PR330/D-M, by using the SD-Pocket software and a PDA or a notebook for BT030). Parameterisation can then be carried out quickly and automatically in an error-free way by transferring data directly from DocWin.

Indicator LEDs

LEDs on the front panel of the trip unit are used to indicate all the pre-alarms (“WARNING”) and alarms (“ALARM”). A message on the display always explicitly indicates the type of event concerned.

Example of events indicated by the “WARNING” LED:

- unbalance between phases;
- pre-alarm for overload ($L1 > 90\% \times I_n$);
- first temperature threshold exceeded (70 °C);
- contact wear beyond 80%;
- phase rotation reversed (with optional PR330/M).

Example of events indicated by the “ALARM” LED:

- timing of function L;
- timing of function S;
- timing of function G;
- second temperature threshold exceeded (85 °C);
- contact wear 100%;
- timing of Reverse Power flow protection (with optional PR330/M).

Data logger

By default PR332/P, is provided with the Data Logger function that automatically records in a wide memory buffer the instantaneous values of all the currents and voltages. Data can be easily downloaded from the unit by means of SD-Pocket or SD-TestBus2 applications and can be transferred to any personal computer for elaboration. The function freezes the recording whenever a trip occurs or in case of other events, so that a detailed analysis of faults can be easily performed. SD-Pocket and SD-TestBus2 allow also reading and downloading of all the others trip information.

- Number of analog channels: 8
- Maximum sampling rate: 4800 Hz
- Maximum sampling time: 27 s (@ sampling rate 600 Hz)
- 64 events tracking.

Trip information and opening data

In case a trip occurs PR332/P store all the needed information:

- Protection tripped
- Opening data (current)
- Time stamp (guaranteed with auxiliary supply or self-supply with power failure no longer than 48h).

By pushing the “Info/Test” pushbutton the trip unit shows all these data directly on display.

No auxiliary power supply is needed. The information is available to user for 48 hours with the circuit breaker open or without current flowing.

The information of the latest 20 trips are stored in memory.

If the information can be furthermore retrieved more than 48 hours later, it is sufficient to connect a PR030/B battery unit or a BT030 wireless communication unit.

Load control

Load control makes it possible to engage/disengage individual loads on the load side before the overload protection L is tripped, thereby avoiding unnecessary trips of the circuit-breaker on the supply side. This is done by means of contactors or switch-disconnectors (externally wired to the trip unit), controlled by the PR332/P through PR021/K unit.

Two different Load Control schemes can be implemented:

- disconnection of two separate loads, with different current thresholds
- connection and disconnection of a load, with hysteresis.

Current thresholds and trip times are smaller than those available for selection with protection L, so that load control can be used to prevent overload tripping. External PR021/K accessory unit is required for Load Control. The function is only active when an auxiliary power supply is available.

PR330/V Measurement Module

This optional internal module, installed in PR332/P, allows the trip unit to measure the phase and neutral voltages and to process them in order to achieve a series of features, in terms of protection and measurement.

PR330/V module, when is ordered mounted on the circuit-breaker, does not require any external connection or voltage transformers since it is connected internally to the upper terminals of Tmax T7 (selector in “INT” position) through the internal voltage sockets. When necessary, the connection of voltage pick-ups can be moved to any other point (i.e. lower terminals), by using the alternative connection located in the terminal box and switching the selector to the “EXT” position. For the dielectric test of the circuit-breaker the selector must be switched to the “Insulating TEST” position. PR330/V is able to energize the PR332/P while line voltage input is above 85 V. The use of Voltage Transformers is mandatory for rated voltages higher than 690 V.

Voltage transformers shall have burdens between 5 VA and 10 VA and accuracy class 0.5 or better.

Additional Protections with PR330/V:

- Undervoltage (UV) protection
- Overvoltage (OV) protection
- Residual voltage (RV) protection
- Reversal of power (RP) protection
- Underfrequency (UF) protection
- Overfrequency (OF) protection.

All the above indicated protections can be excluded, although it is possible to leave only the alarm active when required: in this case the trip unit will indicate the “ALARM” status. With the circuit-breaker closed, these protections also operate when the trip unit is self-supplied. With the circuit-breaker open, they operate when the auxiliary power supply (24 V DC or PR330/V) is present.

Measurement function

The current measurement function (ammeter) is present on all versions of the PR332/P trip unit. The display shows histograms showing the currents of the three phases and neutral on the main page. Furthermore, the most loaded phase current is indicated in numerical format. Earth fault current, where applicable, is shown on a dedicated page.

The latter current value takes on two different meanings depending on whether the external toroidal transformer for the “Source Ground Return” function or the internal transformer (residual type) is connected.

Circuit-breakers for power distribution

Electronic trip units

The ammeter can operate either with self-supply or with an auxiliary power supply voltage. The display is rear-lit and the ammeter is active even at current levels lower than 160 A.

Accuracy of the ammeter measurement chain (current sensor plus ammeter) is no more than 1.5% in the 0.3-6 x I_n current interval of I_n.

- Currents: three phases (L1, L2, L3), neutral (Ne) and earth fault;
- Instantaneous values of currents during a period of time (data logger);
- Maintenance: number of operations, percentage of contact wear, opening data storage (last 20 trips and 20 events).

When the optional PR330/V is connected the following additional measurement function are present:

- Voltage: phase-phase, phase-neutral and residual voltage
- Instantaneous values of voltages during a period of time (data logger)
- Power: active, reactive and apparent
- Power factor
- Frequency and peak factor
- Energy: active, reactive, apparent, counter.

Communication

PR332/P electronic trip unit can be fitted with communication modules, which make possible to exchange data and information with other industrial electronic devices by means of a network.

The basic communication protocol implemented is Modbus RTU, a well-known standard of wide-spread use in industrial automation and power distribution equipment. A Modbus RTU communication interface can be connected immediately and exchange data with the wide range of industrial devices featuring the same protocol. ABB SACE has developed a complete series of accessories for electronic trip unit PR332/P:

- PR330/D-M is the communication module for PR332/P protection trip units. It is designed to allow easy integration of the Tmax circuit-breakers in a Modbus network. The Modbus RTU protocol is of widespread use in the power as well as the automation industry. It is based on a master/slave architecture, with a bandrate of up to 19.2 kbps. A standard Modbus network is easily wired up and configured by means of an RS485 physical layer. ABB SACE trip units work as slaves in the field bus network. All information required for simple integration of PR330/D-M in an industrial communication system are available on the ABB Web page.
- BT030 is a device to be connected to the Test connector of PR222DS/P, PR222DS/PD, PR223DS, PR223EF, PR232/P, PR331/P and PR332/P trip units. It allows Bluetooth communication between the trip unit and a PDA or a Notebook with a Bluetooth port. This device is dedicated to use with the SD-Pocket or SD-TestBus2 application. It can provide the auxiliary supply needed to energize the protection trip unit by means of rechargeable batteries.
- EP010-FBP-PDP22 is the Fieldbus Plug interface allows connection of ABB SACE trip units with Modbus communication to a Profibus, DeviceNet, or AS-I field bus network.

Furthermore, a new generation of software dedicated to installation, configuration, supervision and control of protection trip units and circuit- breakers is now available:

- SD-View 2000
- SD-Pocket
- SD-TestBus2.

All information required for simple integration of PR330/D-M in an industrial communication system are available on the ABB Web page (<http://www.abb.com>).

Measurement, signalling and available data functions

Details about functions available on PR332/P, trip units with PR330/D-M and EP010 – FBP – PDP22 are listed in the table below:

Communication functions	PR332/P +PR330/D-M	PR332/P+PR330/D-M and EP010
Protocol	Modbus RTU standard	FBP-PDP22
Physical means	RS485	Profibus-DP or DeviceNet cable
Speed (maximum)	19.2 kbps	115 kbps
Measurement functions		
Phase currents	■	■
Neutral current	■	■
Ground current	■	■
Voltage (phase-phase, phase-neutral, residual)	opt. ⁽¹⁾	opt. ^{(1) (2)}
Power (active, reactive, apparent)	opt. ⁽¹⁾	opt. ^{(1) (3)}
Power factor	opt. ⁽¹⁾	⁽⁴⁾
Frequency and peak factor	opt. ⁽¹⁾	⁽⁴⁾
Energy (active, reactive, apparent)	opt. ⁽¹⁾	⁽⁴⁾
Harmonic analysis	–	–
Signalling functions		
LED: auxiliary power supply, pre-alarm, alarm, transmission, reception	■	■
Temperature	■	■
Indication for L, S, I, G and other protection	■	■
Available data		
Circuit-breaker status (open, closed)	■	■
Circuit-breaker position (racked-in, racked-out)	■	■
Mode (local, remote)	■	■
Protection parameters set	■	■
Load control parameters	■	■
Alarms		
Protections: L, S, I, G	■	■
Undervoltage, overvoltage and residual voltage protection (timing and trip)	opt. ⁽¹⁾	opt. ⁽¹⁾
Reverse power protection (timing and trip)	opt. ⁽¹⁾	opt. ⁽¹⁾
Directional protection (timing and trip)	–	–
Underfrequency/overfrequency protection (timing and trip)	opt. ⁽¹⁾	opt. ⁽¹⁾
Phases rotation	–	–
Failed tripping under fault conditions	■	■
Maintenance		
Total number of operations	■	■
Total number of trips	■	■
Number of trip tests	■	■
Number of manual operations	■	■
Number of separate trips for each protection function	■	■
Contact wear (%)	■	■
Record data of last trip	■	■
Commands		
Circuit-breaker open/close	■	■
Alarms reset	■	■
Setting of curves and protection thresholds	■	■
Synchronize system time	■	■
Events		
Status changes in circuit-breaker, protections and all alarms	■	■

⁽¹⁾ with PR330/V

⁽²⁾ no residual voltage

⁽³⁾ no apparent power available

⁽⁴⁾ please ask ABB for further details

Circuit-breakers for power distribution

Electronic trip units

Power supply

The PR332/P trip unit does not normally require any external power supplies, being self-supplied from the current sensors (CS): to activate the protection and ammeter functions, it is sufficient for at least one phase to have a current load higher than 80 A.

The unit ensures fully self-supplied operation. When an auxiliary power supply is present, it is also possible to use the unit with the circuit-breaker either open or closed with very low current flowing through (<80 A).

It is also possible to use an auxiliary power supply provided by the PR030/B portable battery unit (always supplied), which allows the protection functions to be set when the trip unit is not self-supplied.

PR332/P stores and shows all the information needed after a trip (protection tripped, trip current, time, date). No auxiliary supply is required for this functionality.

	PR332/P	PR330/D-M
Auxiliary power supply (galvanically insulated)	24 V DC \pm 20%	from PR332/P
Maximum ripple	5%	\pm 5%
Inrush current @ 24 V	3 A for 5 ms	\sim 0.5 A for 5 ms
Rated power @ 24 V	2 W	+1 W
Inrush current @ 24 V when modules connected	5 A for 5 ms	
Rated power @ 24 V when modules connected	3 W	

[†] PR330/V can give power supply to the trip unit when at least one line voltage is equal or higher to 85V RMS.

Zone selectivity





Circuit-breaker for zone selectivity



Index

Circuit-breaker for zone selectivity

Electrical characteristics	2/38
General characteristics.....	2/39
EFDP zone selectivity: PR223EF	2/40
ZS zone selectivity: PR332/P	2/43

Circuit-breaker for zone selectivity

Electrical characteristics

Zone selectivity

				T4	T5	T6	T7	
Rated uninterrupted current	[A]			250/320	400/630	630/800/1000	800/1000/1250/1600	
Poles	[No.]			3/4	3/4	3/4	3/4	
Rated service current, Ue	(AC) 50-60 Hz	[V]		690	690	690	690	
	(DC)	[V]		750	750	750	750	
Rated impulse withstand voltage, Uimp	[kV]			8	8	8	8	
Rated insulation voltage, Ui	[V]			1000	1000	1000	1000	
Test voltage at industrial frequency for 1 min.	[V]			3500	3500	3500	3500	
Rated ultimate short-circuit breaking capacity, Icu				L	L	L	S H L V⁽¹⁾	
	(AC) 50-60 Hz 220/230 V	[kA]		200	200	200	85 100 200 200	
	(AC) 50-60 Hz 380/415 V	[kA]		120	120	100	50 70 120 150	
	(AC) 50-60 Hz 440 V	[kA]		100	100	80	50 65 100 130	
	(AC) 50-60 Hz 500 V	[kA]		85	85	65	40 50 85 100	
	(AC) 50-60 Hz 690 V	[kA]		70	70	30	30 42 50 60	
	(AC) 50-60 Hz 1000 V	[kA]		16	16	-	- - - -	
Rated service short-circuit breaking capacity, Ics								
	(AC) 50-60 Hz 220/230 V	[%Icu]		100%	100%	75%	100% 100% 100% 100%	
	(AC) 50-60 Hz 380/415 V	[%Icu]		100%	100%	75%	100% 100% 100% 100%	
	(AC) 50-60 Hz 440 V	[%Icu]		100%	100%	75%	100% 100% 100% 100%	
	(AC) 50-60 Hz 500 V	[%Icu]		100%	100% ⁽²⁾	75%	100% 100% 75% 100%	
	(AC) 50-60 Hz 690 V	[%Icu]		100%	100% ⁽³⁾	75%	100% 75% 75% 75%	
	(AC) 50-60 Hz 1000 V	[%Icu]		50%	25%	-	- - - -	
Rated short-circuit making capacity, Icm								
	(AC) 50-60 Hz 220/230 V	[kA]		440	440	440	187 220 440 440	
	(AC) 50-60 Hz 380/415 V	[kA]		264	264	220	105 154 264 330	
	(AC) 50-60 Hz 440 V	[kA]		220	220	176	105 143 220 286	
	(AC) 50-60 Hz 500 V	[kA]		187	187	143	84 105 187 220	
	(AC) 50-60 Hz 690 V	[kA]		154	154	63	63 88.2 105 132	
	(AC) 50-60 Hz 1000 V	[kA]		32	32	-	- - - -	
Utilisation category (IEC 60947-2)				A	B (400A) ⁽⁴⁾ - A (630A)	B (630A - 800A) ⁽⁵⁾ - A (1000A)	B ⁽⁶⁾	
Isolation behaviour				■	■	■	■	
Reference Standard				IEC 60947-2	IEC 60947-2	IEC 60947-2	IEC 60947-2	
Trip unit:	electronic	PR223EF		■	■	■	-	
		PR332/P		-	-	-	■	
Versions				F-P-W ⁽⁷⁾	F-P-W ⁽⁷⁾	F-W	F-W	
Terminals	fixed			F-FC Cu-FC CuAl-EF-ES-R-MC ⁽⁸⁾	F-FC Cu-FC CuAl-EF-ES-R ⁽⁸⁾	F-FC CuAl-EF-ES-R-RC	F-EF-ES-FC CuAl-HR/VR	
	plug-in			EF-ES-HR-VR-FC Cu-FC CuAl	EF-ES-HR-VR-FC Cu-FC CuAl	-	-	
	withdrawable			EF-ES-HR-VR-FC Cu-FC CuAl	EF-ES-HR-VR-FC Cu-FC CuAl	EF-HR-VR	EF-HR/VR-ES-RS	
Mechanical life			[No. operations]	20000	20000	20000	10000	
			[No. Hourly operations]	240	120	120	60	
Electrical life @ 415 V AC			[No. operations]	8000 (250A) - 6000 (320A)	7000 (630A) - 5000 (800A)	7000 (630A) - 5000 (800A) - 4000 (1000A)	2000 (S, H, L versions) - 3000 (V version)	
			[No. Hourly operations]	120	60	60	60	
	Basic dimensions - fixed version	3 poles	W [mm]		105	140	210	210
		4 poles	W [mm]		140	184	280	280
D [mm]				103.5	103.5	103.5	154 (manual)/178 (motorizable)	
		H [mm]		205	205	268	268	
Weight	fixed	3/4 poles	[kg]	2.35/3.05	3.24/4.15	9.5/12	9.7/12.5 (manual)/11/14 (motorizable)	
	plug-in	3/4 poles	[kg]	3.6/4.65	5.15/6.65	-	-	
	withdrawable	3/4 poles	[kg]	3.85/4.9	5.4/6.9	12.1/15.1	29.7/39.6 (manual)/32/42.6 (motorizable)	

TERMINAL CAPTION
 EF = Front extended
 F = Front
 ES = Front extended spread
 R = Rear orientated
 MC = Multi-cable

HR = Rear flat horizontal
 VR = Rear flat vertical
 HR/VR = Rear flat horizontal/vertical
 F = Fixed circuit-breaker
 P = Plug-in circuit-breaker
 W = Withdrawable circuit-breaker

⁽¹⁾ Only for T7 800/1000/1250 A
⁽²⁾ 75% for T5 630
⁽³⁾ 50% for T5 630
⁽⁴⁾ Only up to 630 V, I_{cw} = 5 kA
⁽⁵⁾ I_{cw} = 7.6 kA (630 A) - 10 kA (800 A)

⁽⁶⁾ I_{cw} = 20 kA (S, H, L versions) - 15 kA (V version)
⁽⁷⁾ For applications at 1000 V, only available in the fixed version
⁽⁸⁾ For applications at 1000 V, only available with Fc Cu terminals

Note: in the plug-in/withdrawable version of T5 630 the maximum rated current is derated by 10% at 40 °C.

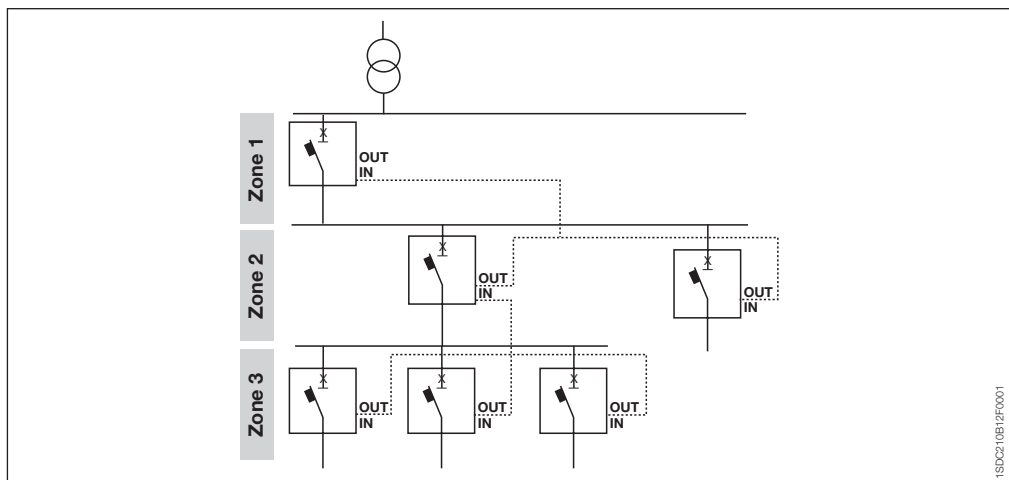

This type of coordination, a development of time coordination, is made by means of logic connections between current measuring devices which, once the set threshold having been exceeded is detected, allow just the fault area to be identified and to have its power supply cut off. By means of zone selectivity it is possible to obtain selectivity considerably reducing the trip times and therefore the thermal stresses all the plant components are subjected to during the fault. Making the protection is done by connecting all the zone selectivity outputs of the trip units belonging to the same zone to each other and taking this signal to the zone selectivity input of the trip unit immediately to the supply side. By means of a simple shielded twisted-pairwire (maximum length of 200 m), each circuit-breaker which detects a fault communicates this to the one on the supply side sending a timed locking signal. The circuit-breaker which does not receive any communication from those on the load side, sends the opening command within the set selectivity time.

- Zone selectivity can be activated for Tmax circuit-breakers in the case where:
- there is a source of 24 V auxiliary power supply;
 - the Tmax T4, T5 or T6 circuit-breaker is equipped with the PR223EF trip unit (EFDP zone selectivity) or Tmax T7 equipped with the PR332/P trip unit (ZS zone selectivity).

Current sensors

	In [A]	160	250	320	400	630	800	1000	1250	1600
PR223EF	T4 250	■	■							
	T4 320			■						
	T5 400			■	■					
	T5 630					■				
	T6 630					■				
	T6 800						■			
	T6 1000							■		
PR332/P	T7 800				▲	▲	■			
	T7 1000				▲	▲	▲	■		
	T7 1250				▲	▲	▲	▲	■	
	T7 1600				▲	▲	▲	▲	▲	■

■ = Complete circuit-breaker already coded
 ▲ = Circuit-breaker to be assembled

When only PR223 are used, it is possible to invert the selectivity chain hierarchy by means of the SW210 interlock module.

For further information on zone selectivity, please consult the section: "Characteristic curves and technical information" on page 4/73.

Circuit-breaker for zone selectivity

EFDP Zone selectivity: PR223EF

The PR223EF electronic trip unit available on T4, T5 and T6 in the L version (120 kA @ 380/415 V) for use in alternating current, is able to isolate a fault present in extremely rapid times.

This performance is made possible thanks to the EFDP (Early Fault Detection and Prevention) algorithm, which is able to detect the short-circuit at its onset, exploiting analysis of the trend of the shunted current in relation to the current. The PR223EF trip unit therefore offers two performances simultaneously which, until today, were antithetic: selectivity and trip rapidity.

Thanks to extremely rapid detection and quenching of the short-circuit, the MCCB equipped with this trip unit are totally selective up to over 100 kA, and are not subject to any limits regarding the number of hierarchical levels of the installation. Trip rapidity, together with just as rapid transmission of the order to wait, allow a high number of circuit-breakers to be interlocked, making a global selectivity chain in the installation: by using the PR223EF no limitation in topological terms is introduced, with distances between interlocked circuit-breakers reaching up to 1 Km, thereby making the protection system highly flexible.

EFDP zone selectivity is carried out by means of a logic interlocking protocol (Interlocking, IL). The connection is made by means of a simple screened-twisted-pair cable which connects the circuit-breakers fitted with the PR223EF. In the case of a fault, the circuit-breaker immediately to the supply side sends a locking signal to the hierarchically higher circuit-breaker by means of the bus and, before intervening, checks that a similar locking signal has not been reached by the circuit-breakers on the load side.

The soundness of the system is controlled by a monitoring function of the interlock channel, guaranteeing the system a very high level of safety.

All the protection functions can be programmed remotely using the dialogue function present on the trip unit or locally by means of the PR010/T which can be connected to a serial port on the front of the PR223EF.

The trip unit can be supplied from a 24 V DC auxiliary source or directly through the current transformers (self-supply). The electronic trip unit operation is guaranteed even in the case of single-phase load up to $0.18 \times I_n$.

In the presence of an auxiliary power supply:

- the device implements the L, S, EF and G protection functions; if the EF is disabled by the user, function I is enabled
- EFDP zone selectivity is implemented on the S, EF and G functions.

If it is under self-supply conditions:

- the trip unit disables the EF, implementing the classic protection functions which also characterize the PR223/DS trip unit: L, S, I and G
- EFDP zone selectivity is not enabled.

Auxiliary power supply - Electrical characteristics

	PR223EF
Auxiliary power supply (galvanically insulated)	24 V DC \pm 20%
Maximum ripple	\pm 5%
Inrush current @ 24 V	~4 A for 0.5 ms
Rated current @ 24 V	~80 mA
Rated power @ 24 V	~2 W

Connection of the logic interlock and auxiliary power supply is made by means of the X3 and X4 connectors located on the back of the trip unit.

For the neutral, it is possible set the protection threshold of the functions to OFF, at 50% and at 100% that of the phase, by means of the dialogue function or PR010/T. Furthermore, pre-alarm and alarm signalling of protection L is available on the front of the trip units. The pre-alarm threshold value is $0.9 \times I_n$.

The PR223EF trip unit, just like the PR223DS one, allows storage and display of information regarding a trip unit trip. The information is saved permanently and up to 20 trip events are recorded, which can be acquired by a supervision system using the Modbus protocol or can be displayed locally by means of the FDU or PR010/T unit.

PR223EF

Socket for connection of PR10/T test unit and BT030 wireless communication unit

Socket for TT1 test unit

LED signalling alarm of the circuit-breaker

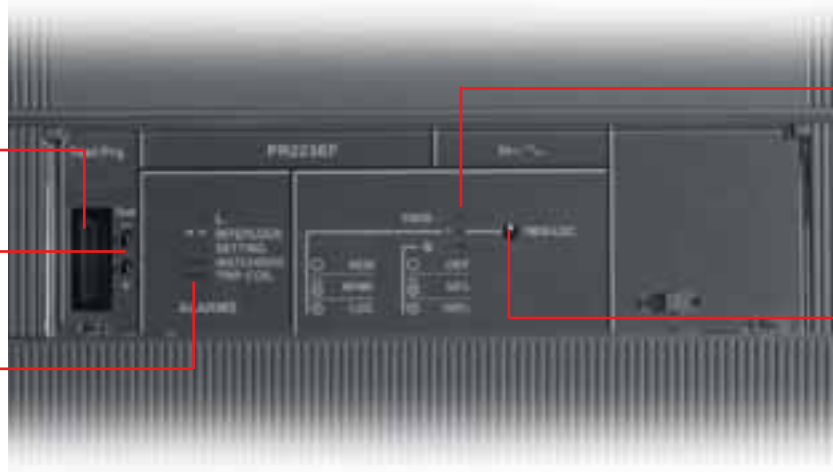

LED signalling the status of the circuit-breaker

Push button for operation mode selection (local/remote) and on-board diagnosis system

1SDC210215F1002

PR223EF - Protection functions and parameterisations

Protection functions	Trip threshold	Trip curves ⁽¹⁾	Excludability	Relation t = f(I)	EFDP zone selectivity
L Against overload with long inverse time-delay trip and trip characteristic according to an inverse time curve (I ² t=k) according to the IEC 60947-2 Standard	Electronic setting I ₁ = 0.18...1 x I _n ⁽²⁾ step 0.01 x I _n Trip between 1.1...1.3 x I ₁ (IEC 60947-2)	Electronic setting at 6 x I ₁ t ₁ = 3...18s ⁽²⁾ step 0.5s Tolerance: ± 10%	–	t = k/I ²	–
S Against short-circuit with short inverse time-delay trip and trip characteristic with inverse time (I ² t=k) or with definite time	Electronic setting I ₂ = 0.60...10 x I _n ⁽³⁾ step 0.1 x I _n Tolerance: ± 10%	Electronic setting⁽³⁾ at 8 x I _n t ₂ = 0.05...0.5s step 0.01s Tolerance: ± 10%	■	t = k/I ²	■
	Electronic setting I ₂ = 0.60...10 x I _n ⁽³⁾ step 0.1 x I _n Tolerance: ± 10%	Electronic setting t ₂ = 0.05...0.5s step 0.01s Tolerance: ± 10%	■	t = k	■
Ef Against short-circuit with ultra rapid trip ⁽⁴⁾			■	t = k	■
I Against short-circuit with instantaneous trip with adjustable threshold	Electronic setting I ₃ = 1.5...12 x I _n ⁽³⁾ step 0.1 x I _n Tolerance: ± 10%	instantaneous	■	t = k	–
G Against earth fault with inverse short time delay trip and trip characteristic with inverse time (I ² t=k)	Electronic setting I ₄ = 0.2...1 x I _n (step 0.1 x I _n) Tolerance: ± 10%	Electronic setting t ₄ = 0.1...0.8s (step 0.01s) Tolerance: ± 15%	■	t = k/I ²	■

⁽¹⁾ These tolerances are valid under the following conditions:
– trip unit self-supplied at full power and/or auxiliary supply;
– two or three-phase power supply;

In conditions other than those considered, the following tolerances hold:

	Trip threshold	Trip curves
S	± 20%	± 20%
I	± 20%	≤ 50ms
G	± 20%	± 20%

⁽²⁾ For T4. I_n = 320 A and T5. I_n = 630 A ⇒ t₁ = 10.5s

⁽³⁾ For T4 I_n = 320 A, T5 I_n = 630 A and T6 I_n = 1000 A ⇒ I_{2,max} = 9.5 x I_n, I_{3,max} = 9.5 x I_n
For T6 I_n = 800 A ⇒ I_{3,max} = 10.5 x I_n

⁽⁴⁾ Active in auxiliary power supply (24 V DC)

⁽⁵⁾ For I₁ < 0.4 x I_n the neutral setting must be at 100% of that of the phases

Circuit-breaker for zone selectivity

EFDP Zone selectivity: PR223EF

The information recorded when the protection release trips is:

- Currents (L1, L2, L3, N) which caused opening
- Events
- States
- Alarms
- Trips
- Tripped protection
- Parameters of the tripped protection.

When there is an auxiliary power supply, providing it is complete with the VM210 module, the PR223EF enables you to see not only the currents but also the voltages in the system, both locally via the FDU or HMI030, and remotely via a supervisor system using the Modbus protocol. In addition, up to 20 trip events can be recorded, even in self-supply mode.

PR223EF - Measurements

Measurements	With distributed N	Without distributed N
Effective current values	I_1, I_2, I_3, I_{ne}	I_1, I_2, I_3
Effective voltage values	$V_1, V_2, V_3, V_{12}, V_{23}, V_{31}$	V_{12}, V_{23}, V_{31}
Phase peak factor	■	■
Frequency	f	f

The PR223EF trip unit is an integral part of the circuit-breaker and is therefore not interchangeable with the other protection trip units available on T4, T5 and on T6.

Circuit-breaker for zone selectivity

ZS Zone selectivity: PR332/P

With the PR332/P trip unit (see chapter: “Tmax circuit-breakers for power distribution”, page 2/27 and foll.) it is now possible to extend the ZS zone selectivity function, already available on ABB SACE Emax air circuit-breakers to the Tmax moulded-case circuit-breakers.

The ZS zone selectivity, which is applicable to protection functions S and G, can be enabled in the case where the curve with fixed time is selected and the auxiliary power supply is present.

To realize correctly the ZS zone selectivity the following settings are suggested for the upstream circuit-breaker:

S	$t_2 \geq t_2 \text{ set time} + 70 \text{ ms}^*$
I	$I_3 = \text{OFF}$
G	$t_4 \geq t_4 \text{ set time} + 70 \text{ ms}^*$
Selectivity time	same setting for each circuit-breaker

* At minimum between the trip times of two CBs in series, with auxiliary power supply.

** See page 2/28 for $t_{2\text{set}}$ and $t_{4\text{set}}$ settings.

To carry out the cabling, a shielded twisted pair cable (not supplied with the trip unit; ask ABB for information) can be used. The shield should only be earthed on the trip unit of the circuit-breaker on the supply side.

The maximum length of the cabling for zone selectivity, between two units, is 200 meters.

The maximum number of the circuit-breakers which can be connected to the outputs (Z out) of a trip unit is 16.

The ZS of selectivity is identical to that which can be obtained through the trip units type PR333/P (for Emax X1) and PR122/P- PR123/P (for Emax). Tmax T7 circuit-breaker equipped with PR332/P can be connected directly without external accessories on the load side of a zone selectivity chain created through the other devices (PR333/P, PR122/P and PR123/P).

For example:

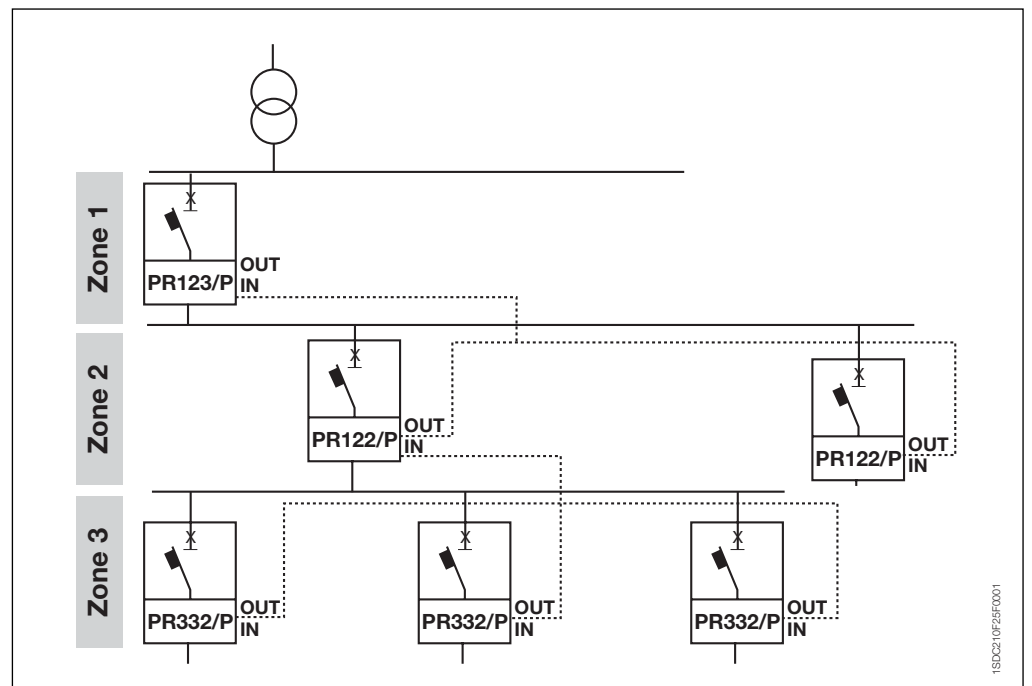

1SDC210015D0205

Motor Protection





Circuit-breakers for motor protection



Index

Circuit-breakers for motor protection

Electrical characteristics	2/46
General characteristics.....	2/48
Protection against short-circuit	2/49
Integrated protection: PR221MP.....	2/51
Integrated protection: PR222MP.....	2/52

Circuit-breakers for motor protection

Electrical characteristics

Motor Protection

Rated uninterrupted current	[A]
Rated service current, I_n	[A]
Poles	[No.]
Rated service current, U_e	(AC) 50-60 Hz [V] (DC) [V]
Rated impulse withstand voltage, U_{imp}	[kV]
Rated insulation voltage, U_i	[V]
Test voltage at industrial frequency for 1 min.	[V]
Rated ultimate short-circuit breaking capacity, I_{cu}	[kA]
(AC) 50-60 Hz 220/230 V	[kA]
(AC) 50-60 Hz 380/415 V	[kA]
(AC) 50-60 Hz 440 V	[kA]
(AC) 50-60 Hz 500 V	[kA]
(AC) 50-60 Hz 690 V	[kA]
Rated service short-circuit breaking capacity, I_{cs}	[%I _{cu}]
(AC) 50-60 Hz 220/230 V	[%I _{cu}]
(AC) 50-60 Hz 380/415 V	[%I _{cu}]
(AC) 50-60 Hz 440 V	[%I _{cu}]
(AC) 50-60 Hz 500 V	[%I _{cu}]
(AC) 50-60 Hz 690 V	[%I _{cu}]
Rated short-circuit making capacity, I_{cm}	[kA]
(AC) 50-60 Hz 220/230 V	[kA]
(AC) 50-60 Hz 380/415 V	[kA]
(AC) 50-60 Hz 440 V	[kA]
(AC) 50-60 Hz 500 V	[kA]
(AC) 50-60 Hz 690 V	[kA]
Opening time (415 V)	[ms]
Utilisation category (IEC 60947-2)	
Isolation behaviour	
Reference Standard	
Protection against short-circuit	
Magnetic only trip unit	MA
Electronic trip unit	PR221DS-I PR231/P-I
Integrated protection (IEC 60947-4-1)	
Electronic trip unit	PR221MP PR222MP
Interchangeability	
Versions	
Terminals	fixed plug-in withdrawable
Fixing on DIN rail	
Mechanical life	[No. operations]
Electrical life @ 415 V AC	[No. operations]
Basic fixed version dimensions	W [mm] D [mm] H [mm]
Weight	fixed [kg] plug-in [kg] withdrawable [kg]

Tmax T2

Tmax T3

160	250
1...100	100...200
3	3
690	690
500	500
8	8
800	800
3000	3000
N S H L	N S
65 85 100 120	50 85
36 50 70 85	36 50
30 45 55 75	25 40
25 30 36 50	20 30
6 7 8 10	5 8
100% 100% 100% 100%	75% 50%
100% 100% 100% 75% (70 kA)	75% 50% (27 kA)
100% 100% 100% 75%	75% 50%
100% 100% 100% 75%	75% 50%
100% 100% 100% 75%	75% 50%
143 187 220 264	105 187
75.6 105 154 187	75.6 105
63 94.5 121 165	52.5 84
52.5 63 75.6 105	40 63
9.2 11.9 13.6 17	7.7 13.6
3 3 3 3	7 6
A	A
■	■
IEC 60947-2	IEC 60947-2
■ (MF up to I _n 12.5 A)	■
■	-
-	-
■	-
-	-
-	-
F - P	F - P
F - FC Cu - FC CuAl - EF - ES - R	F - FC Cu - FC CuAl - EF - ES - R
F - FC Cu - FC CuAl - EF - ES - R	F - FC Cu - FC CuAl - EF - ES - R
-	-
DIN EN 50022	DIN EN 50022
25000	25000
240	240
8000	8000
120	120
90	105
70	70
130	150
1.1	1.5
-	-
1.5	2.7

TERMINAL CAPTION

F = Front
EF = Front extended
ES = Front extended spread
FC Cu = Front for copper cables
R = Rear orientated

FC CuAl = Front for CuAl cables

MC = Multicable
HR = Rear flat horizontal
VR = Rear flat vertical
HR/VR = Rear flat orientated

⁽¹⁾ 75% for T5 630

⁽²⁾ 50% for T5 630

⁽³⁾ I_{cw} = 5 kA

⁽⁴⁾ I_{cw} = 10 kA

⁽⁵⁾ I_{cw} = 20 kA (S, H, L versions) - 15 kA (V version)

Note: in the plug-in version of T2, T3 and T5 630, and in the withdrawable version of T5 630 the maximum rated current is derated by 10% at 40 °C.

Tmax T4					Tmax T5					Tmax T6				Tmax T7			
250/320					400/630					630/800				800/1000/1250			
10...320					320, 400, 630					630, 800				-			
3					3					3				3			
690					690					690				690			
750					750					750				-			
8					8					8				8			
1000					1000					1000				1000			
3500					3500					3500				3500			
N	S	H	L	V	N	S	H	L	V	N	S	H	L	S	H	L	V
70	85	100	200	200	70	85	100	200	200	70	85	100	200	85	100	200	200
36	50	70	120	200	36	50	70	120	200	36	50	70	100	50	70	120	150
30	40	65	100	180	30	40	65	100	180	30	45	50	80	50	65	100	130
25	30	50	85	150	25	30	50	85	150	25	35	50	65	40	50	85	100
20	25	40	70	80	20	25	40	70	80	20	22	25	30	30	42	50	60
100%	100%	100%	100%	100%	100%	100%	100%	100%	100%	100%	100%	100%	75%	100%	100%	100%	100%
100%	100%	100%	100%	100%	100%	100%	100%	100%	100%	100%	100%	100%	75%	100%	100%	100%	100%
100%	100%	100%	100%	100%	100%	100%	100%	100%	100%	100%	100%	100%	75%	100%	100%	100%	100%
100%	100%	100%	100%	100%	100%	100%	100%	100% ⁽¹⁾	100% ⁽²⁾	100%	100%	100%	75%	100%	100%	75%	100%
100%	100%	100%	100%	100%	100%	100%	100% ⁽¹⁾	100% ⁽²⁾	100% ⁽²⁾	75%	75%	75%	75%	100%	75%	75%	75%
154	187	220	440	660	154	187	220	440	660	154	187	220	440	187	220	440	440
75.6	105	154	264	440	75.6	105	154	264	440	75.6	105	154	220	105	154	264	330
63	84	143	220	396	63	84	143	220	396	63	94.5	105	176	105	143	220	286
52.5	63	105	187	330	52.5	63	105	187	330	52.5	73.5	105	143	84	105	187	220
40	52.5	84	154	176	40	52.5	84	154	176	40	46	52.5	63	63	88.2	105	132
5	5	5	5	5	6	6	6	6	6	10	9	8	7	15	10	8	8
A					B (400 A) ⁽³⁾ - A (630 A)					B ⁽⁴⁾				B ⁽⁵⁾			
■					■					■				■			
IEC 60947-2/IEC 60947-4					IEC 60947-2/IEC 60947-4					IEC 60947-2/IEC 60947-4				IEC 60947-2			
■					-					-				-			
■					■					■				-			
-					-					-				■			
-					-					-				-			
■					■					■				-			
■					■					■				■			
F - P - W					F - P - W					F - W				F - W			
F - FC Cu - FC CuAl - EF - ES - R - MC - HR - VR					F - FC Cu - FC CuAl - EF - ES - R - HR - VR					F - FC CuAl - EF - ES - R - RC				F - EF - ES - FC CuAl - HR/VR			
EF - ES - R - FC Cu - FC CuAl - HR - VR					EF - ES - R - FC Cu - FC CuAl - HR - VR					-				-			
EF - ES - FC Cu - FC CuAl					EF - ES - FC Cu - FC CuAl					EF - HR - VR				EF - HR/VR - ES - RS			
-					-					-				-			
20000					20000					20000				10000			
240					120					120				60			
8000					7000					5000				2000 (S, H, L versions) / 3000 (V version)			
120					60					60				60			
105					140					210				210			
103.5					103.5					103.5				154 (manual) / 178 (motorizable)			
205					205					268				268			
2.35					3.25					9.5/12				9.7/12.5 (manual) - 11/14 (motorizable)			
3.6					5.15					-				-			
3.85					5.4					12.1/15.1				29.7/39.6 (manual) - 32/42.6 (motorizable)			

Circuit-breakers for motor protection

General characteristics

Starting, switching and protection of three-phase asynchronous motors are basic operations for their correct use. ABB SACE proposes two different solutions for this type of application:

- a **traditional system**, which foresees a circuit-breaker for protection against short-circuit, a thermal relay for protection against overload and missing or unbalanced phase and a contactor for motor switching;
- a **system of integrated protection** thanks to the PR222MP trip unit, which ensures both protection against short-circuit, and against overload, as well as that against missing or unbalanced phase and that against the rotor block.

All this must necessarily take into account the problems which arise at the moment of starting.

In particular, when selecting these devices, different factors must be taken into consideration, such as:

- the motor power
- the diagram and type of starting
- the type of motor: with cage rotor or with wound rotor
- the fault current at the point of the network where the motor is installed.

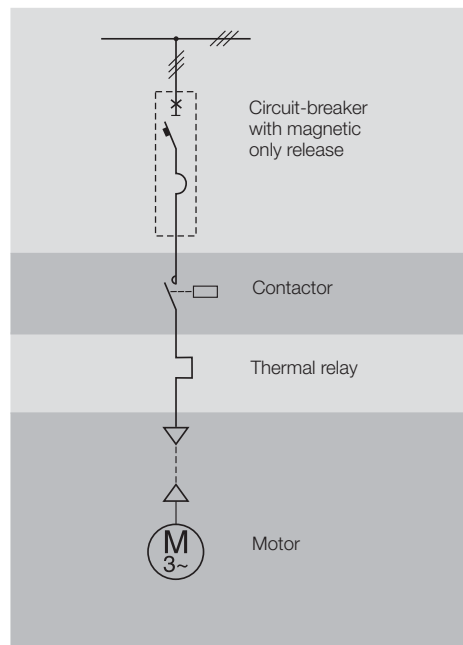

Protection against short-circuit

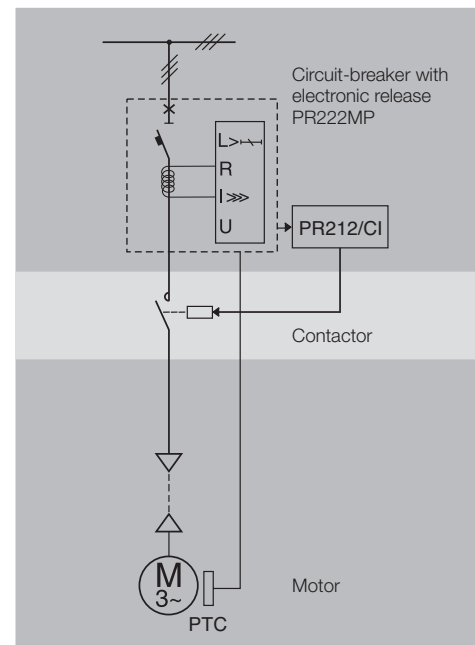

Integrated protection

Circuit-breakers for motor protection

Protection against short-circuit

With the new series of Tmax moulded-case circuit-breakers, ABB SACE proposes a range up to 400 A, which implementing exclusively the protection against short-circuit, is suitable for use inside protected starters of traditional type.

The Tmax T2, T3 and T4 circuit-breakers in the three-pole version with fixed magnetic only trip unit (only for T2, $I_3 = 13 \times I_n$ up to $I_n = 12.5$ A) or adjustable between 6 and 12 times the rated service current for T2 and T3, and between 6 and 14 times for T4, stand out for their compactness and exceptional performances in terms of breaking capacity and limitation of the specific let-through energy. Furthermore, thanks to the great flexibility given by the wide range of magnetic threshold settings, they allow optimal motor protection.

They can be used in a wide range of start-ups, from 0.37 kW to 45 kW for T2 and up to 250 kW for T5 (at 400 V).

Finally, thanks to their wide setting range of protection against short-circuit, T2, T4, T5 and T6, in the three-pole version equipped with PR221DS-I electronic trip units and T7, in three-pole version equipped with PR231/P-I electronic trip units, allow the most suitable trip value to be selected for any type of motor for rated currents up to 1250 A and 560 kW (at 400 V).



MF – Fixed magnetic only trip units

Tmax T2



I_n [A]	1	1.6	2	2.5	3.2	4	5	6.5	8.5	11	12.5
$I_3 = 13 \times I_n$	13	21	26	33	42	52	65	84	110	145	163

Note: The magnetic only trip units which equip the Tmax T2 in three-pole version circuit-breaker have a trip threshold I_3 fixed at $13 \times I_n$, according to what is indicated in the table.

MA – Adjustable magnetic only trip units

Tmax T2-T3-T4



I_n [A]	10	20	25	32	52	80	100	125	160	200
Tmax T2		■		■	■	■	■			
Tmax T3							■	■	■	■
Tmax T4	■		■		■	■	■	■	■	■
Tmax T2, T3 $I_3 = 6 \dots 12 \times I_n$	–	120...240	–	192...384	312...624	480...960	600...1200	750...1500	960...1920	1200...2400
Tmax T4 $I_3 = 6 \dots 14 \times I_n$	60...140	–	150...350	–	312...728	480...1120	600...1400	750...1750	960...2240	1200...2800

Note: The magnetic only trip units which equip the Tmax T2 and T3 three-pole version circuit-breakers have a trip threshold I_3 which can be adjusted from 6 to $12 \times I_n$ for T2 and T3 and from 6 to $14 \times I_n$ for T4, according to what is indicated in the table.

Circuit-breakers for motor protection

Protection against short-circuit

Current sensors

	In [A]	10	25	63	100	160	250	320	400	630	800	1000	1250	1600
PR221DS-I	T2 160	■	■	■	■	■								
	T4 250				■	■	■							
	T4 320				▲	▲	▲	■						
	T5 400							■	■					
	T5 630							▲	▲	■				
	T6 630									■				
	T6 800										■			
	PR231/P-I	T7 800									▲	■		
T7 1000										▲	▲	■		
T7 1250										▲	▲	▲	■	
T7 1600										▲	▲	▲	▲	■
I ₃ [A]		10...100	25...250	63...630	100...1000	160...1600	250...2500	320...3200	400...4000	630...6300	800...8000	1000...10000	1250...12500	1600...16000

■ = Complete circuit-breaker already coded

▲ = Circuit-breaker to be assembled

PR221DS-I

Protection function	Trip threshold	Excludability	Relation t=f(I)
 Against short-circuit with adjustable instantaneous trip	$I_3 = 1 - 1.5 - 2 - 2.5 - 3 - 3.5 - 4.5 - 5.5 - 6.5 - 7 - 7.5 - 8 - 8.5 - 9 - 10 \times I_n$ Tolerance: ± 20% (T2) ± 10% (T4-T5, T6)	■	t = k

Note: The tolerances are valid under the following hypotheses:

- relay self-supplied on running and/or auxiliary power supply (without start up)
- two-phase or three-phase power supply

In all the cases not foreseen by the above-mentioned hypotheses, the following tolerance values are valid:

	Trip threshold	Trip time
I	± 20%	≤ 40ms

PR231P-I

Protection function	Trip threshold	Excludability	Relation t=f(I)
 Against short-circuit with adjustable instantaneous trip	$I_3 = 1 - 1.5 - 2 - 2.5 - 3 - 3.5 - 4.5 - 5.5 - 6.5 - 7 - 7.5 - 8 - 8.5 - 9 - 10 \times I_n$ Tolerance: ± 10%	-	t = k

Note: The tolerances are valid under the following hypotheses:

- relay self-supplied on running and/or auxiliary power supply (without start up)
- two-phase or three-phase power supply

In all the cases not foreseen by the above-mentioned hypotheses, the following tolerance values are valid:

	Trip threshold	Trip time
I	± 15%	≤ 60ms

Circuit-breakers for motor protection

Integrated protection: PR221MP

The PR221MP electronic release is dedicated to protection of motors with powers up to 55 kW. The L protection function protects the motor from overloads according to the indications and classes defined by the IEC 60947-4-1 Standard. The function can be adjusted manually, $I_1 = 0.65...1 \times I_n$, by means of the dip switches on the front of the release. Then the start-up class of the motor must be selected which determines the trip time for overload, in accordance with the IEC 60947-4-1 Amend. 2, Table 2 Standards: "Class 3E" corresponds to a trip time of $t_1 = 2.77s$, "Class 5E" $t_1 = 4.16s$, "Class 10E" $t_1 = 8.33s$, and "Class 20E" $t_1 = 11.1s$ at $7.2 \times I_1$. The protection against short-circuit allows adjustment of the trip threshold up to 17.5 times the rated current, $I_3 = 2.5...17.5 \times I_n$. As for Tmax T2 PR221DS, it is necessary to house the opening solenoid (SA) in the right-hand slot of the circuit-breaker. Tmax T2 PR221MP can be fitted with the same electrical accessories available with PR221DS.

PR221MP

Protection L
Against overload





Socket for TT1 test unit

Protection I
Against short-circuit with instantaneous trip

1SDC210B60F0001

PR221MP – Protection and parameterisation functions

Protection function ⁽¹⁾	Trip threshold	Trip curves	Excludability	Relation $t = f(I)$
 <p>Against overload with long inverse time delay trip and trip characteristic according to an inverse time curve ($I^2t = \text{constant}$) according to IEC 60947-2 Standard</p>	$I_1 = 0.65 - 1 \times I_n$ step = $0.05 \times I_n$	Trip classes: 3E - 5E - 10E - 20E Protection for unbalanced phase not available	-	-
 <p>Against short-circuit with instantaneous trip with adjustable threshold</p>	$I_3 = 2.5...17.5 \times I_n$ step = $1 \times I_n$ Tolerance: $\pm 20\%$ (T2)	instantaneous	-	$t = k$

⁽¹⁾ The tolerances are valid with these hypotheses:
 – self-supplied release at full power and/or auxiliary power supply (without start up)
 – two-phase or three-phase power supply
 For all the cases not foreseen in the above hypotheses, the following tolerance values are valid:

	Trip threshold	Trip time
I	$\pm 20\%$	$\leq 40ms$

Circuit-breakers for motor protection

Integrated protection: PR222MP



1SDC210B14#0001

In the three-pole version, the Tmax T4, T5 and T6 circuit-breakers are fitted with PR222MP electronic trip units. This makes it possible to obtain functions which guarantee high trip precision, extreme reliability and immunity to variations in the external temperature. The PR222MP trip units fully integrated on board the circuit-breaker guarantee complete protection of the motor. In fact, it is not necessary to provide the help of an external thermal relay for protection against overloads as, on the other hand, occurs with the standard solution.

The PR222MP can be connected to a contactor for the basic protection function (NORMAL mode) of the motor: the circuit-breaker can control contactor opening in the case of a fault (excluding short-circuit), by means of the SACE PR212/CI accessory control unit. In fact, a contactor has breaking capacities at high currents which are less efficient than the circuit-breaker, but a high number of possible operations consistently higher than those of the circuit-breaker (about 1.000.000). The combination of the two devices therefore optimises motor protection and control. In Heavy operation mode and for currents below the set magnetic trip threshold, the PR222MP trip unit allows control of the circuit-breaker opening and not of the contactor. In this operating mode, the circuit-breaker is therefore called on to protect the plant under any overcurrent conditions, assigning just motor control operations (turning on and turning off) to the contactor.

PR222MP electronic trip unit - Current sensors

Tmax T4-T5-T6

In [A]	100	160	200	320	400	630
T4 250	■	■	■			
T5 400				■	■	
T6 800						■

■ = Complete circuit-breaker already coded

In any case, the PR010/T unit for testing the trip unit and checking the protection functions, and the PR021/K signalling unit are available for the PR222MP trip unit. The electronic trip units are self-supplied and are made up of three current transformers, the PR222MP protection unit and a trip coil which acts directly on the circuit-breaker operating mechanism. The current transformers, housed inside the trip unit, supply the energy and the signal required for correct protection operation. Operation is guaranteed with a single-phase current equal to 20% of the rated current. The trip unit is temperature-compensated and is sensitive to missing phase according to Table IV of the IEC60947-4-1 7.2.1.5.2 Standards.

The T4, T5 and T6 circuit-breakers for motor protection are perfectly integrated with the new line of ABB contactors. The latter - defined as A-line - together with the line of thermal relays and ABB SACE moulded-case circuit-breakers, is the basis for the new generation of apparatus specially designed to guarantee a system of products which can be integrated according to the required applications. All this has the aim not only of continually improving the products, but above all of providing designers, installers and end users with the best solutions in terms of performances and reliability, combined with the simplicity of the system.

The Tmax T4 and T5 circuit-breakers with PR222MP trip unit and the "A" series of contactors are, in particular, an extraordinary solution in terms of compactness, sharing the same width and thereby saving space, assembly material, installation time and relative cabling operations. The combination of circuit-breaker-contactor allows an extremely compact protected starter to be made.

Typical operating characteristic of an asynchronous motor

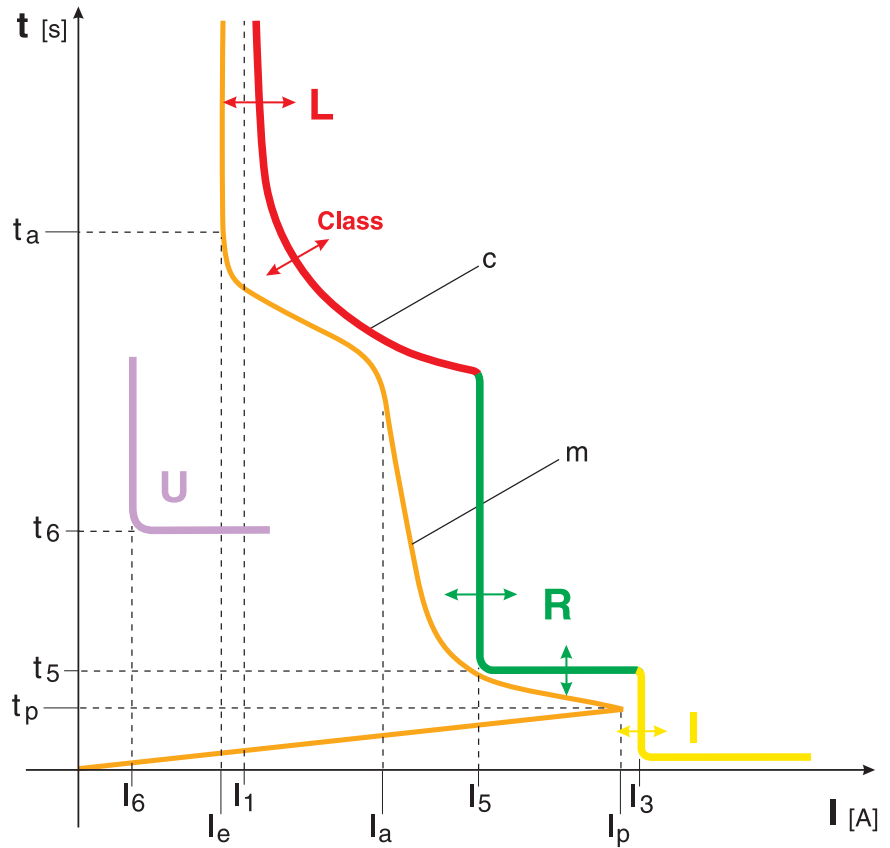

1SDC210015D0205

- I_1 = function L trip current
 - I_3 = function I trip current
 - I_5 = function R trip current
 - t_5 = function R trip time
 - t_6 = function U trip time
 - I_6 = function U trip current
 - t_a = motor starting time
 - t_p = duration of the sub-transient starting phase
 - I_e = rated service current of the motor
 - I_a = motor starting current
 - I_p = peak value of the sub-transient starting current
 - m = typical motor starting curve
 - c = example of trip curve of a motor protection circuit-breaker with electronic release
- The different curves of the functions, with numerous threshold and time settings, allow an overall trip curve to be drawn which is really close to the motor starting curve, thereby optimising its protection.

Circuit-breakers for motor protection

Integrated protection: PR222MP

Protection functions



(L) Protection against overload

Function L protects the motor against overloads according to the indications and classes defined by the IEC 60947-4-1 Standard.

The protection is based on a pre-defined model (ABB SACE international patent) which, by simulating the copper and iron over-temperatures inside the motor, allows precise safeguarding of the motor. The protection intervenes when the established over-temperature is reached. The trip time is fixed by selecting the trip class defined in the above-mentioned Standard.

The function is temperature-compensated and sensitive to a missing/unbalanced phase according to the IEC 60947-4-1 Standard.

In the case of an auxiliary power supply, the thermal memory function is guaranteed, which allows the trip unit to continue to calculate the motor temperature even following an opening.

Function L, which cannot be excluded, can be set manually to $I_1 = 0.4...1 \times I_n$ with 60 thresholds which can be set by means of the dip-switches on the front of the trip unit, or electronically by means of the SACE PR010T test and configuration unit.

The starting class of the motor must then be selected, which determines the trip time for overload according to the IEC 60947-4-1 5.7.3 Table II Standards: class 10 A corresponds to a trip time $t_1 = 4s$, class 10 to $t_1 = 8s$, class 20 to $t_1 = 16s$ and class 30 to $t_1 = 24s$ at $7.2 \times I_n$. Setting this trip time can also be carried out electronically with the PR010T: the electronic steps are equal to 1s.

Tripping of this protection leads to contactor opening (with the PR212/CI unit). Any anomaly of the contactor would make the circuit-breaker open, thanks to the BACK UP function.

For protection L, there is then a pre-alarm and an alarm LED: the pre-alarm threshold value is fixed and equal to $0.9 \times I_1$ and the LED is permanently lit, whereas it flashes in case of alarm ($I > 1.05 \times I_1$). It is also possible to transmit remotely the alarm of protection L, simply connecting connector X_3 to the dedicated contact.



(R) Protection against rotor block

Function R protects the motor against possible rotor block during operation. Protection R has the characteristic of protecting the motor in two different ways, according to whether the fault is present at start-up or whether it is present during normal service of an already active plant.

In the former case, protection R is linked to protection L for time selection as well: in the presence of a fault during start-up, protection R is inhibited for a time equal to the time set with the trip class. Once this time is exceeded, protection R becomes active leading to a trip after a fixed set t_5 time. In the latter case, protection R is already active and the protection tripping time will be equal to t_5 . The protection intervenes when at least one of the phase currents exceeds the established value and remains over that threshold for time t_5 .

Function R can be set manually $I_5 = 3...10 \times I_1$ with 8 thresholds which can be set by means of the dip-switches on the front of the trip unit, or with 70 thresholds by means of the SACE PR010T test and configuration unit (steps of $0.1 \times I_1$). The trip time t_5 can be set to 1, 4, 7 or 10 seconds by means of a dip-switch, or with steps of 0.5s by means of PR010T.

Tripping of this protection leads to contactor opening (with the PR212/CI unit); any anomaly of the contactor would make the circuit-breaker open, thanks to the BACK UP function.



(I) Protection against short-circuit

This protection function intervenes in the case of a short-circuit between phases. It is sufficient for just a single phase to exceed the set threshold to cause immediate opening of the circuit-breaker (protection cannot be excluded).

The PR222MP trip unit is able to recognise whether the motor to be protected is in the start-up phase or if there is a short-circuit: this has the aim of allowing completely safe start-up conditions. It cannot be excluded.

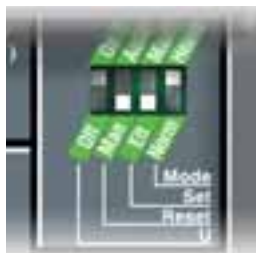

1SDC210B19FX001

(U) Protection against missing phase and/or unbalanced

Function U can be used in those cases where a particularly precise control is needed regarding phase missing/unbalanced. This protection can be excluded and intervenes if the effective value of one or two currents drops below the level equal to 0.4 of the current I_1 set for protection L and remains there for longer than 4 seconds.

This protection can be set electronically with the PR010T from 0.4 to $0.9 \times I_1$ with time adjustable between 1 and 10s (steps of 0.5s).

Tripping of this protection leads to contactor opening (with the PR212/CI unit); any anomaly of the contactor would make the circuit-breaker open, thanks to the BACK UP function.

Parameterisation of the PR222MP trip unit

Man/Elt: by means of a dip switch located on the front, the trip unit can be provided for manual parameterisation (Man) of the thresholds and times acting directly on the dip switches located on the front of the trip unit or with electronic parameterisation (Elt) by means of the PR010T.

Reset Mode

Auto/Man: this function (AUTO) allows the state of activation of the PR212/CI to be automatically reset following contactor trip for L function, after a fixed time of 15s. The AUTO reset is only possible when there is an auxiliary voltage.

Setting the working modes

Normal: the Normal mode foresees the use of a circuit-breaker and a contactor: this configuration makes intervention towards the contactor possible, through the PR212/CI unit, when the PR222MP considers this appropriate.

Heavy: the heavy mode foresees circuit-breaker opening for all overcurrent conditions, and the contactor is assigned just the motor operation function.

BACK UP Function

This protection is conceived to manage the possibility that an opening command sent to the contactor might not have a positive outcome, i.e. that the contactor does not intervene. In this case, after having waiting for the time defined using the dip switch "k time" (min = 80ms or max = 160ms), the PR222MP sends a trip signal to the circuit-breaker.

By introducing a time delay between the command sent to the contactor and to the back-up one, it is necessary to compensate the contactor actuation time.



1SDC210B26FX001

Setting the PTC protection

PTC: by means of a PTC sensor inserted in the motor, this protection controls the internal temperature of the protected motor. In the case of excessive temperature, the PR222MP release will command opening of the contactor (if it is in "Normal" mode) or of the circuit-breaker (if it is in "Heavy" mode).

O/I: in this mode, as an alternative to the PTC protection, it is possible to signal the state of a generic contact without potential by means of the ABB SACE PR021/K signalling unit (see page 3/43) (for the electrical circuit diagram, see page 5/20).

Circuit-breakers for motor protection

Integrated protection: PR222MP

PR222MP

Protection R

Against rotor block

Protection L

Against motor overload

Socket for connection of SACE PR010/T test unit and BT030 wireless communication unit

Socket for SACE TT1 test unit

Class

Class of motor starting according to the IEC 60947-4-1 Standards

Selection between:
- PTC⁽¹⁾ temperature sensor input
- 0/1 generic input

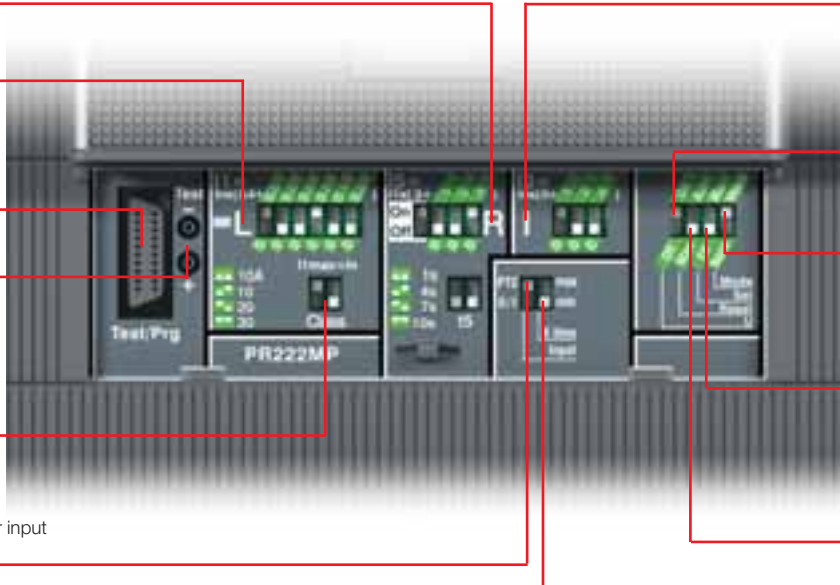

Protection I

Against short-circuit with instantaneous trip

Protection U

Against phase current unbalance or loss of phase

Setting the work methods

Man/Elt

Release parametrisation methods

Setting the reset following trip
- manual
- automatic

Setting the back-up time

⁽¹⁾ A special input is available to connect a PTC temperature probe, inserted in the motor to be protected

PR222MP - Protection functions and parameterisation

Protection functions	Trip threshold	Trip curves ⁽¹⁾	Excludability	t = f(l)	Thermal memory ⁽²⁾
L Against overload with long inverse time delay trip and trip characteristic according to an inverse time curve according to IEC 60947-4-1 Standard	Manual setting $I_1 = 0.4 \dots 1 \times I_n$ step = $0.01 \times I_n$ Tolerance: $\pm 15\%$	Manual setting Trip classes: 10 A - 10 - 20 - 30 (IEC 60497-4-1) $t_1 = 4-8-16-24$ s where t_1 is the trip time at $7.2 \times I_1$ cold, depending on the class selected	-	-	■
	Electronic setting $I_1 = 0.4 \dots 1 \times I_n$ step = $0.01 \times I_n$ Tolerance: $\pm 15\%$	Electronic setting $t_1 = 4 \dots 24$ s step = 1s Tolerance: $\pm 15\%$			
R Against rotor block with delayed trip and trip characteristic with definite time	Manual setting $I_2 = \text{OFF} - 3 \dots 10 \times I_1$ step = $1 \times I_1$ Tolerance: $\pm 15\%$	Manual setting $t_2 = 1 - 4 - 7 - 10$ s Tolerance: $\pm 10\%$	■	$t = k/l^2$	-
	Electronic setting $I_2 = \text{OFF} - 3 \dots 10 \times I_1$ step = $0.1 \times I_1$ Tolerance: $\pm 15\%$	Electronic setting $t_2 = 1 \dots 10$ s step = 0.5s Tolerance: $\pm 10\%$			
I Against short-circuit with instantaneous trip	Manual setting $I_3 = 6 \dots 13 \times I_n$ step = $1 \times I_n$ Tolerance: $\pm 15\%$	instantaneous	-	$t = k^{(3)}$	-
	Electronic setting $I_3 = 6 \dots 13 \times I_n$ step = $0.1 \times I_n$ Tolerance: $\pm 15\%$				
U Against phase current unbalance or loss of phase with delayed trip and trip characteristic with definite time	Manual setting $I_6 = \text{ON} (0.4 \times I_1) - \text{OFF}$ Tolerance: $\pm 15\%$	Manual setting $t_6 = 4$ s Tolerance: $\pm 10\%$	■	$t = k$	-
	Electronic setting $I_6 = 0.4 \dots 0.9 \times I_1 - \text{OFF}$ Tolerance: $\pm 15\%$	Electronic setting $t_6 = 1 \dots 10$ s step 0.5s Tolerance: $\pm 10\%$			

⁽¹⁾ These tolerances hold in the following conditions:
- self-powered trip unit at full power and/or auxiliary supply (without start-up);
- two or three-phase power supply.

In conditions other than those considered, the following tolerances hold:

	Trip threshold	Trip time
R	$\pm 20\%$	$\pm 20\%$
I	$\pm 20\%$	≤ 50 ms
U	$\pm 20\%$	$\pm 20\%$

⁽²⁾ Available in auxiliary supply at 24 V DC

⁽³⁾ Full power: $t = t_5$
Start up: $t = t_1 + t_5$

1150 V AC and 1000 V DC





Circuit-breakers for use up to 1150 V AC and 1000 V DC



Index

Circuit-breakers for use up to 1150 V AC and 1000 V DC

Electrical characteristics2/60

Circuit-breakers for use up to 1150 V AC and 1000 V DC

Electrical characteristics

The range of T4, T5 and T6 circuit-breakers for applications in direct current at 1000 V or in alternating current up to 1150 V (T6 up to 1000 V) also comes into the panorama of the Tmax proposals.

The typical sectors of use are installations in mines, road and railway tunnels, electrical transport and industrial applications in general.

The circuit-breakers are available in the three-pole and four-pole version with TMD or TMA adjustable thermomagnetic releases or with PR221DS, PR222DS/P, PR222DS/PD, PR222MP and PR223EF electronic trip units (see the dedicated section on page 2/37).

The dimensions of these circuit-breakers are the same as the standard one. The Tmax circuit-breakers for these applications are available in the fixed, plug-in and withdrawable version (for which the use of the 1000 V fixed parts supplied only by upper terminals is mandatory) and they are compatible with all the accessories except for the residual current release.

T4-T5 circuit-breakers for use up to 1150 V AC and T6 circuit-breakers for use up to 1000 V AC

		Tmax T4		Tmax T5		Tmax T6	
Rated uninterrupted current	[A]	250		400/630		630/800	
Poles		3, 4		3, 4		3, 4	
Rated service voltage, Ue	(AC) 50-60 Hz [V]	1000	1150	1000	1150	1000	
Rated impulse withstand voltage, Uimp	[kV]	8		8		8	
Rated insulation voltage, Ui	[V]	1000	1150	1000	1150	1000	
Test voltage at power frequency for 1 min.	[V]	3500		3500		3500	
Rated ultimate short-circuit breaking capacity, Icu		L	V⁽¹⁾	L	V⁽¹⁾	L⁽¹⁾	
(AC) 50-60 Hz 1000 V	[kA]	12	20	12	20	12	
(AC) 50-60 Hz 1150 V	[kA]	12		12			
Rated service short-circuit breaking capacity, Ics							
(AC) 50-60 Hz 1000 V	[kA]	12	12	10	10	6	
(AC) 50-60 Hz 1150 V	[kA]	6		6			
Rated short-circuit making capacity, Icm							
(AC) 50-60 Hz 1000 V	[kA]	24	40	24	40	24	
(AC) 50-60 Hz 1150 V	[kA]	24		24			
Category of use (IEC 60947-2)		A		B (400 A) ⁽²⁾ - A (630 A)		B ⁽³⁾	
Behaviour on isolation		■		■		■	
Reference Standards		IEC 60947-2		IEC 60947-2		IEC 60947-2	
Thermomagnetic releases	TMD	■					
	TMA	■		■		■	
Electronic trip units	PR221DS/LS/I	■	■	■	■	■	
	PR221DS/I	■	■	■	■	■	
	PR222DS/P_LSI	■	■	■	■	■	
	PR222DS/P_LSIG	■	■	■	■	■	
	PR222DS/PD_LSI	■	■	■	■	■	
	PR222DS/PD_LSIG	■	■	■	■	■	
	PR222MP	■		■			
Terminals		FC Cu		FC Cu		F - FC CuAl - R	
Version		F, P, W	F	F, P, W ⁽⁴⁾	F	F ⁽⁵⁾	
Mechanical life	[No. operations]	20000		20000		20000	
	[No. hourly operations]	240		120		120	
Basic fixed dimensions ⁽⁶⁾	3 poles	W [mm]		140		210	
	4 poles	W [mm]		184		280	
		D [mm]		103.5		103.5	
		H [mm]		205		268	
Weight	fixed	3/4 poles	[kg]	2.35 / 3.05	2.35 / 3.05	3.25 / 4.15	3.25 / 4.15
	plug-in	3/4 poles	[kg]	3.6 / 4.65		5.15 / 6.65	
	withdrawable	3/4 poles	[kg]	3.85 / 4.9		5.4 / 6.9	

TERMINAL CAPTION

F = Front
FC Cu = Front for copper cables
FC CuAl = Front for copper cables CuAl

R = Rear
F = Fixed circuit-breakers
P = Plug-in circuit-breakers
W = Withdrawable circuit-breakers

⁽¹⁾ Power supply only from the top

⁽²⁾ Icw = 5 kA

⁽³⁾ Icw = 7.6 kA (630 A) - 10 kA (800 A)

⁽⁴⁾ Tmax T5630 is only available in the fixed version

⁽⁵⁾ For T6 in the withdrawable version, please ask ABB SACE

⁽⁶⁾ Circuit-breaker without high terminal covers

PR221DS and PR222DS for use up to 1150 V AC - Current sensor

Tmax T4-T5-T6						
In [A]	100	250	320	400	630	800
T4 250	■	■				
T5 400			■	■		
T5 630					■	
T6 630 ⁽¹⁾					■	
T6 800 ⁽¹⁾						■

Note: For the PR222MP setting, please see page 2/56
⁽¹⁾ up to 1000 V



Circuit-breakers for use at 1000 V DC

		Tmax T4	Tmax T5	Tmax T6
Rated uninterrupted current	[A]	250	400/630	630/800
Poles		4	4	4
Rated service voltage, U_e	[V]	1000	1000	1000
Rated impulse withstand voltage, U_{imp}	[kV]	8	8	8
Rated insulation voltage, U_i	[V]	1150	1150	1000
Test voltage at power frequency for 1 min.	[V]	3500	3500	3500
Rated ultimate short-circuit breaking capacity, I_{cu}		V⁽²⁾	V⁽²⁾	L⁽²⁾
(DC) 4 poles in serie ⁽¹⁾	[kA]	40	40	40
Rated service short-circuit breaking capacity, I_{cs}				
(DC) 4 poles in serie	[kA]	20	20	
Category of use (IEC 60947-2)		A	B (400 A) ⁽³⁾ - A (630 A)	B ⁽⁴⁾
Behaviour on isolation		■	■	■
Reference Standards		IEC 60947-2	IEC 60947-2	IEC 60947-2
Thermomagnetic releases		■	-	-
	TMD	■	■	■
	TMA			
Terminals		FC Cu	FC Cu	F - FC CuAl - R
Interchangeability		■	■	■
Versions		F	F	F ⁽⁵⁾
Mechanical life		20000	20000	20000
	[No. operations]			
	[No. hourly operations]	240	120	120
Basic fixed dimensions	4 poles			
	W [mm]	140	184	280
	D [mm]	103.5	103.5	103.5
	H [mm]	205	205	268
Weight	fixed			
	4 poles	3.05	4.15	12

TERMINAL CAPTION
 F = Front
 FC Cu = Front for copper cables
 FC CuAl = Front for copper cables CuAl
 R = Rear
 F = Fixed circuit-breakers

⁽¹⁾ See the wiring diagrams on page 4/65 diagram D
⁽²⁾ Power supply only from above
⁽³⁾ I_{cw} = 5 kA
⁽⁴⁾ I_{cw} = 7.6 kA (630 A) - 10 kA (800 A)
⁽⁵⁾ For T6 in the withdrawable version, please ask ABB SACE

Thermomagnetic trip unit for use up to 1150 V AC and 1000 V DC - TMD and TMA

In [A]	32	50	80	100	125	160	200	250	320	400	500	630	800
Neutral [A] - 100%	32	50	80	100	125	160	200	250	320	400	500	630	800
 I₁ = 0.7...1 x I_n	T4 250	■	■	■	■	■	■	■					
	T5 400								■	■			
	T5 630										■		
	T6 630											■	
	T6 800												■
 I₃ = 10 x I_n I₃ = 5...10 x I_n	I ₃ = 10 x I _n [A]	320	500										
	I ₃ = 5...10 x I _n [A]	-	-	400...800	500...1000	625...1250	800...1600	1000...2000	1250...2500	1600...3200	2000...4000	2500...5000	3150...6300

Switch-disconnectors





Index

Switch-disconnectors

Electrical characteristics	2/64
----------------------------------	------

Switch-disconnectors

Electrical characteristics

The Tmax switch-disconnectors derive from the corresponding circuit-breakers, of which they keep the overall dimensions, versions, fixing systems and the possibility of mounting accessories unchanged. This version only differs from the circuit-breakers in the absence of the protection trip units. They are characterised by a rated voltage of 690 V in alternating current and 750 V in direct current.

Switch-disconnectors

				Tmax T1D
Conventional thermal current, Ith		[A]		160
Rated service current in category AC22, Ie		[A]		160
Rated service current in category AC23, Ie		[A]		125
Poles		[No.]		3/4
Rated service voltage, Ue	(AC) 50-60 Hz	[V]		690
	(DC)	[V]		500
Rated impulse withstand voltage, Uimp		[kV]		8
Rated insulation voltage, Ui		[V]		800
Test voltage at industrial frequency for 1 minute		[V]		3000
Rated short-circuit making capacity, Icm (min) switch-disconnector only		[kA]		2.8
	(max) with circuit-breaker on supply side	[kA]		187
Rated short-time withstand current for 1s, Icw		[kA]		2
Reference Standard				IEC 60947-3
Versions				F
Terminals				FC Cu - EF -
				FC CuAl
Mechanical life		[No. operations]		25000
		[No. Hourly operations]		120
Basic dimensions, fixed	3 poles	W [mm]		76
	4 poles	W [mm]		102
		D [mm]		70
		H [mm]		130
Weight	fixed	3/4 poles	[kg]	0.9/1.2
	plug-in	3/4 poles	[kg]	-
	withdrawable	3/4 poles	[kg]	-

Switch-disconnector coordination [380/415 V AC]

	T1			T2				T3		T4					T5 400				
	B	C	N	N	S	H	L	N	S	N	S	H	L	V	N	S	H	L	V
Icu [kA]	16	25	36	36	50	70	85	36	50	36	50	70	120	200	36	50	70	120	200
T1D 160	16	25	36	36	50	70	85												
T3D 250								36	50	36	50	70	120	200					
T4D 320										36	50	70	120	200					
T5D 400															36	50	70	120	200
T5D 630																			
T6D 630																			
T6D 800																			
T6D 1000																			
T7D 1000																			
T7D 1250																			
T7D 1600																			

Applications

They can be used as general circuit-breakers in sub-switchboards as switching and isolation parts for lines, busbars or groups of apparatus, or as bus-ties. They can be part of general isolation devices of groups of machines or of complexes for motor switching and protection.

Isolation

The main function carried out by this apparatus consists of isolation of the circuit they are inserted in. Once the contacts are open they are at a distance which prevents an arc from striking, in accordance with the prescriptions in the standards regarding isolation behaviour. The position of the operating lever corresponds definitely with that of the contacts (positive operation).

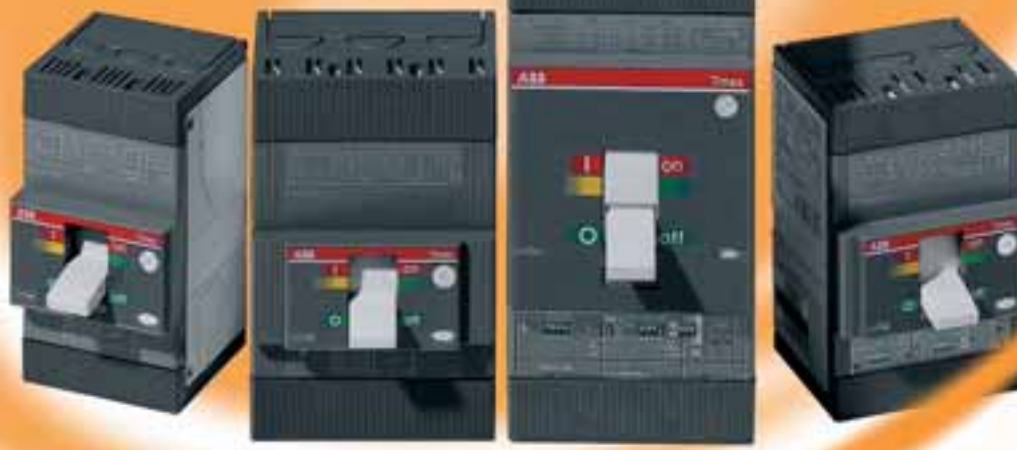



Index

Versions and types	3/2
Connection terminals	3/7
Service releases	3/16
Electrical signals.....	3/20
Remote control.....	3/25
Operating mechanisms and locks.....	3/30
Residual current releases	3/36
Accessories for electronic trip units	3/40
Test and configuration accessories.....	3/46
Automatic transfer switch - ATS010.....	3/47
Installation accessories and spare parts.....	3/50
Compatibility of internal accessories	3/51
Communication devices and systems	3/52

Accessories

Versions and types

Starting from the fixed version with front terminals, the Tmax circuit-breakers can be converted into the various versions (plug-in for T2, T3, T4 and T5; withdrawable for T4, T5, T6 and T7), using the conversion kits. This makes management of the product, its versions and stocks as a whole very flexible. In any case, it is always possible to request the circuit-breaker in the desired version completely preset in the factory, by ordering, on the same line, the fixed circuit-breaker and the conversion kit, to which must be added the fixed part.

T7 is available in two different versions: the lever operating mechanism version similar to the other sizes in the Tmax family, and the new motorizable version.



1SDC210039F0001

Fixed

The Tmax FIXED three-pole or four-pole version circuit-breakers foresee:

- circuit-breakers characterised by just two depths up to 1000 A: 70 mm for Tmax T1, T2 and T3 and 103.5 mm for Tmax T4, T5 and T6. For T7 the depth varies according to the type of operating mechanism (with lever or spring charging motor)
- standard front in groups of circuit-breakers: 45 mm for Tmax T1, T2 and T3 and 105 mm for T4 and T5, 140 mm for T6 and 280 mm for T7
- flange for compartment door
- possibility of assembly on back plate (or on DIN rail with T1, T2 and T3, with the help of the special accessory, see page 3/50)
- thermomagnetic (on Tmax T1, T2, T3, T4, T5 and T6) or electronic (on Tmax T2, T4, T5, T6 and T7) trip units
- standard FC Cu type terminals (front for copper cables) for T1 and F type (front) on all the Tmax family sizes.



1SDC210039F0001

Plug-in

The PLUG-IN version of the circuit-breaker (Tmax T2, T3, T4 and T5) consists of:

- fixed part to be installed directly on the back plate of the unit
- moving part obtained from the fixed circuit-breaker with addition of the isolating contacts (near the connection terminals), of the rear frame (for fixing to the fixed part) and of the terminal covers.

The circuit-breaker is racked out by unscrewing the top and bottom fixing screws. A special lock prevents circuit-breaker racking in and racking out with the contacts in the closed position.

In the case where the circuit-breaker has electrical accessories mounted (SOR, UVR, MOS, MOE, MOE-E, AUX, AUX-E, AUE, RC222), the socket-plug connectors or the adapters for isolation of the relative auxiliary circuits must also be ordered (see page 3/28).



Withdrawable

The circuit-breakers in the WITHDRAWABLE version (Tmax T4, T5, T6⁽¹⁾ and T7) are made up of:

- fixed part to be installed directly on the back plate of the unit fitted with lateral guides to allow the moving part racking-in and racking-out operation to be carried out easily, and a dedicated flange for the compartment door to replace the one provided with the circuit-breaker in the fixed version;
- moving part obtained from the fixed circuit-breaker with addition of the relative conversion kit from fixed to withdrawable moving part;
- mandatory accessory to be applied onto the front of the circuit-breaker selected between front for lever operating mechanism (standard supply for circuit-breakers fitted with accessories in the factory, excluding T7) motor operator and rotary handle operating mechanism. Application of one of these accessories allows the racking-in and racking-out of the moving part with the compartment door closed (on T7 no accessory is required to have racking-out with the door closed).

Racking-in and racking-out of the moving part is carried out by means of the special operating lever always supplied with the fixed part. This particular device allows the circuit-breaker to be placed in the isolated position (with power and auxiliary circuits disconnected) with the compartment door closed, to the great advantage of operator safety. The handle can only be inserted with the circuit-breaker open. Once removed or racked-out, the circuit-breaker can be operated in open/closed and, by means of special connection extensions, blank tests can be carried out of the auxiliary control circuit functions.

The T4, T5 and T6 circuit-breakers in the withdrawable version can only be fitted with pre-wired electrical accessories, provided with the appropriate ADP adapters for isolation of the relative auxiliary circuits (see page 3/28).

Motorizable

The T7 circuit-breaker in the motorizable version can be equipped with the spring charging motor. To allow a complete remote control with T7 motorizable, the circuit-breaker must be fitted with:

- shunt opening release;
- shunt closing release;
- spring charging motor.

Versions available

	F Fixed	P Plug-in	W Withdrawable
T1	■		
T2	■	■	
T3	■	■	
T4	■	■	■
T5	■	■	■
T6	■		■
T7	■		■
T7M	■		■

⁽¹⁾ Not available on the 1000 A version.

Accessories

Versions and types



1SDC210026F0001

Fixed part - FP

The fixed part, available for all the sizes of the Tmax family starting from T2, allows the circuit-breaker to be made in the plug-in or withdrawable version. Different positions of the circuit-breaker are possible:

- plug-in: connected, removed;
- withdrawable: connected, removed, racked-out for test (only for T7), racked-out.

In the standard version, the fixed parts of T2 and T3 are available with front terminals (F). A distinctive characteristic is the possibility of fitting these fixed parts with the same terminal, terminal cover and phase separator kits used for the fixed circuit-breakers. With Tmax T4, T5, T6 and T7, fixed parts with dedicated front and rear terminals are available. Moreover, the fixed parts of T4 and T5 with front terminals can also be fitted with the special ES, FC Cu and FC CuAl terminals.

The rear flat terminals of the fixed parts of Tmax T7 are orientated (horizontally or vertically). Factory assembly is horizontal as standard. By means of the extra code 1SDA063571R1, it is possible to ask for the fixed part with vertical terminals. This extra code can be associated either with the top terminals or with the bottom ones (in the case of asking for assembly of both the terminals vertically, the extra code must be repeated twice). The anti-racking-in locks, to be mounted on the left side of the fixed part, and which prevent racking-in of incorrect moving parts are supplied as standard fitting of the fixed parts of Tmax T7. In detail, it is possible to define the different ways of combination between the fixed part and the moving part according to: T7 with lever or which can be motorised, breaking capacity and rated uninterrupted current.



1SDC210026F0001

Kit for conversion of fixed part of plug-in into fixed part of withdrawable

For Tmax T4 and T5 is available a conversion kit which is made up by a guide to prepare the fixed part of the circuit-breaker in the plug-in version in the fixed part of the circuit-breaker in the withdrawable version, a racking-out crank handle and by the flange for the compartment door to replace the one supplied with the fixed or plug-in circuit-breaker version.



1SDC210007F0001

Racking-out crank handle

This allows racking-out and racking-in of the circuit-breaker in the withdrawable version into the fixed part, with the door closed. The crank handle is the same for the whole range of circuit-breakers and is automatically supplied with the fixed part of withdrawable circuit-breakers or with the conversion kit for fixed part of plug-in into fixed part of withdrawable.



1SDC210016F0001

Sliding contacts blocks

The sliding contacts blocks are required for Tmax T7 in withdrawable version equipped with electrical accessories or with an electronic trip unit. Their function is to realize the electrical connections of the secondary circuits between the mobile part and the fixed part and these blocks work in pairs: one block is to be mounted on the mobile part and the respective one on the fixed part. The following table combines the types of sliding contacts blocks and the electrical accessories.

Left block	Central block	Right block
Spring charging motor	PR331	Auxiliary contacts (Q or SY)
Spring charged contact (AUX-SC)	PR332	Shunt opening release
Ready to close contact (AUX-RTC)		Shunt closing release
Early auxiliary contacts (AUE)		Under voltage release
Contact for signalling trip coil release trip (AUX-SA)		
Trip reset		

If at least one of the electrical accessories listed in the previous table is fitted on the circuit breaker the respective pair of blocks must be mounted on the mobile part and on the fixed part.



1SDC210C08F0001

T2-T3



1SDC210C06F0001

T4-T5



1SDC210C10F0001

T4-T5-T6



1SDC210D17F0001

T7

Kit for conversion into moving part of plug-in for T2 - T3 - T4 - T5

Allows the fixed circuit-breaker with front terminals to be converted into the moving part of a plug-in circuit-breaker. The kit consists of:

- isolating contacts
- anti-racking out safety device
- assembly screws and nuts
- low terminal covers for the moving part.

The fixed part for plug-in version is necessary to complete the circuit-breaker.

Kit for conversion into moving part of withdrawable for T4 - T5 - T6 - T7

Allows the fixed circuit-breaker with front terminals to be converted into the moving part of a withdrawable circuit-breaker. The kit consists of:

- isolating contacts
- frame
- assembly screws and nuts
- low terminal covers for the moving part.

The circuit-breakers in the withdrawable version must always be completed either with the front for lever operating mechanism (standard supply for circuit-breakers fitted with accessories in the factory, excluding T7), rotary handle operating mechanism or motor operator.

The fixed part for withdrawable version is necessary to complete the circuit-breaker.

The kit for converting a fixed CB into a withdrawable version is not available for the T6 1000 A circuit-breaker.

Accessories

Versions and types

Kit for conversion of fixed part into plug-in for RC222 and RC223 residual current releases

With the dedicated conversion kit, the RC222 and RC223 residual current releases for T4 and T5 as well can be converted from the fixed to the plug-in version. The kit consists of four copper busbars which make the connection between the terminals of the residual current relay and the isolating contacts mounted on the circuit-breaker terminals.

Therefore, to obtain a circuit-breaker fitted with the residual current release accessory in the plug-in version, the two kits for conversion of circuit-breakers and for residual current release must be ordered.

The power circuit is connected to the connection terminals of the fixed part.

Kit for conversion of plug-in into withdrawable for RC222 and RC223 residual current releases

The RC222 and RC223 residual current releases for T4 and T5 can be converted from the plug-in to withdrawable version by adding the special kit consisting of a bellows to be applied on the front of the residual current release to allow racking-out of the circuit-breaker and of the residual current release with the switchgear door closed.

This kit can also be mounted on the fixed version circuit-breaker when there is the front for locks or the direct rotary handle operating mechanism, therefore widening the range of use of the residual current releases.

Accessories

Connection terminals

The basic version circuit-breaker is supplied with:

- front terminals for copper cables (FC Cu), for the Tmax T1 circuit-breaker
- front terminals (F), for all the other Tmax family sizes.

Different types of terminals, which can be combined together in different ways, are also available (top of one type, bottom of a different type), thereby allowing the circuit-breaker to be connected to the plant in the most suitable way in relation to installation requirements.

The following can be distinguished:

- **front terminals** which allow connection of cables or busbars working directly from the front of the circuit-breaker
- **orientated rear terminals** which allow installation of the circuit-breakers in switchboards with rear access to both the cable and busbar connections.

Terminals are available for direct connection of bare copper or aluminium cables and terminals for connection of busbars or cables with cable lugs.

On page 3/9 and following, the information needed to make the connections for each type of terminal is summarised. For connection with bare cables, the minimum and maximum cross-sections of the cables, which can be clamped in the terminals, the type of cables (rigid or flexible) and the diameter of the terminal are indicated. For connections with busbars, flat terminals of different sizes and composition are recommended.

The torque values to be applied to the tightening screws of the terminals for cables and to the screws used to connect the busbars to the flat terminals are indicated.

The circuit-breakers can be ordered complete with the terminals required (mounted directly in the factory), by associating the terminal kit codes with the code of the standard version circuit-breaker, or the terminals can be ordered individually in packs of 3 - 4 - 6 or 8 pieces.

To receive the circuit-breaker with mixed terminals, the two terminal half-kits must be specified, loading the one to be mounted on top as the first half-kit and then the one to be mounted below.

If the top terminals are the same as the bottom ones, it is compulsory to order the complete kit (6 or 8 pieces) and not the two half-kits: the configuration would not be accepted by the system.

Insulating terminal covers

The terminal covers are applied to the circuit-breaker to prevent accidental contact with live parts and thereby guarantee protection against direct contacts. The following are available:

- low terminal covers (LTC): these guarantee IP30 degree of protection for fixed circuit-breakers with rear terminals and for moving parts of plug-in and withdrawable circuit-breakers
- high terminal covers (HTC): these guarantee IP40 degree of protection, for fixed circuit-breakers with front, front extended, front for cables terminals.

With Tmax T2 and T3, the fixed parts of plug-in circuit-breakers can use the same terminal covers as the corresponding fixed circuit-breakers. For fixed parts of T4 and T5, the proper terminal covers (TC-FP) are available.

The degrees of protection indicated at page 1/8 are valid for the circuit-breaker installed in a switchboard.



1SDC210C11F0001



1SDC210C12F0001

Accessories

Connection terminals

Phase separators

These allow the insulation characteristics between the phases at the connections to be increased. They are mounted from the front, even with the circuit-breaker already installed, inserting them into the corresponding slots and they are available in two versions:

- 100 mm high
- 200 mm high.

The H=100 mm phase separators are supplied as compulsory with front extended type terminals (EF), whereas the ones with height H=200 mm are compulsory with front extended spread type terminals (ES).

The phase separating partitions are incompatible with both the high and low insulating terminal covers.

The fixed parts can use the same phase separating partitions as the corresponding fixed circuit breakers.

With the phase separating partitions mounted, on request, with Tmax T1, T2 and T3 a special kit is available to reach IP40 degree of protection from the front of the circuit-breaker.

It is possible to mount the phase separating partitions between two circuit-breakers or fixed parts side by side.

Screws for sealing the terminal covers

These are applied to the terminal covers of fixed circuit-breakers or to the moving parts of plug-in or withdrawable circuit-breakers. They prevent removal of both the high and low terminal covers and can be locked with a wire and lead seal.



Kit for taking up the auxiliary power supply

Special kits are available with the fixed version of Tmax T2, T3, T4 and T5 circuit-breakers for taking up the auxiliary power supply directly from the connection terminals. They can only be combined with the front terminals for copper cables (FC Cu) for T2, T3 and T4 or with the front terminals (F) for T4-T5.

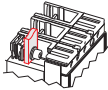
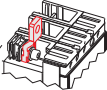

Connection terminals

Circuit-breaker

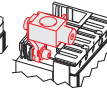
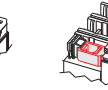
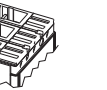
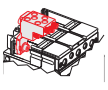
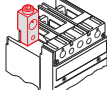
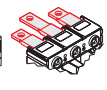
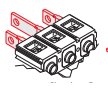
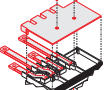
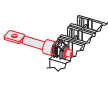
	F	EF	ES	FC Cu	FC CuAl	FC CuAl	MC	RC CuAl	HR	VR	HR for RC221/222	R
												
	Front terminals	Front extended terminals	Front extended spread terminals	Front terminals for copper cables	Front terminals for CuAl cables	Front terminals for CuAl cables ⁽¹⁾	Multi-cable terminals	Rear terminals for CuAl cables	Rear flat horizontal terminals	Rear flat vertical terminals	Rear flat horizontal terminals	Rear horizontal terminals
T1		F		F ⁽²⁾		F			F		F	
T2	F ⁽²⁾	F	F	F	F	F						F
T3	F ⁽²⁾	F	F	F	F	F						F
T4	F ⁽²⁾	F	F	F	F	F	F					F
T5	F ⁽²⁾	F	F	F	F	F						F
T6 630	F ⁽²⁾	F	F		F			F				F
T6 800	F ⁽²⁾	F	F			F		F				F
T6 1000		F ⁽²⁾⁽³⁾	F ⁽³⁾			F ⁽³⁾						F ⁽³⁾
T7	F ⁽²⁾	F	F			F			F	F		F

⁽¹⁾ Housed externally

⁽²⁾ Standard supply

⁽³⁾ A type of terminal among those indicated in the table must necessarily be mounted on the T6 1000 A circuit-breaker (complete circuit-breaker, breaking part and loose protection trip unit).

F = Fixed

Fixed part

	F	EF	ES	FC Cu	FC CuAl	FC CuAl	R	RS	HR	VR	HR/VR
	Front terminals	Front extended terminals	Front extended spread terminals	Front terminals for copper cables	Front terminals for CuAl cables	Front terminals for CuAl cables ⁽¹⁾	Rear horizontal terminals	Rear spreaded terminals	Rear flat horizontal terminals	Rear flat vertical terminals	Rear flat terminals
T2	P ⁽²⁾	P	P	P	P	P	P				
T3	P ⁽²⁾	P	P	P	P	P	P				
T4		P-W		P-W	P-W				P-W	P-W	
T5		P-W	P ⁽³⁾ -W ⁽³⁾	P-W	P-W				P-W	P-W	
T6		W							W	W	
T7		W	W					W			W

⁽¹⁾ Housed externally

⁽²⁾ Standard supply

⁽³⁾ For T5 630 only

P = Plug-in

W = Withdrawable

Accessories

Connection terminals

Front terminals - F

Allow connection of busbars or cables terminated with cable terminal



Type	Version	Pieces	Busbars/cable terminal [mm]				Tightening [Nm]	Terminal covers			Phase separators
			W	H	D	Ø		high	low	fixed part	
T2	F-P	1	20	7.5	5	6.5	6	R	R	-	R
T3	F-P	1	24	9.5	8	8.5	8	R	R	-	R
T4	F	1	25	9.5	8	8.5	18	R	R	-	R
T5	F	1	35	11	10 ⁽¹⁾	10.5	28	R	R	-	R
T6 630	F	2	40	12	5	2 x 7	9	R	R	-	R
T6 800	F	2	50	12	5	2 x 7	9	R	R	-	R
T7 1250 ⁽²⁾	F	2	50	20	8	2 x 11	18	-	R	-	R
T7 1600	F	2	50	20	10	2 x 11	18	-	R	-	R

⁽¹⁾ minimum 5 mm

⁽²⁾ up to 1250 A



Front extended terminals - EF

Allow connection of busbars or cables terminated with cable terminal



Type	Version	Pieces	Busbars [mm]			Cable terminal [mm]		Tightening [Nm]		Terminal covers			Phase separators
			W	D	Ø	W	Ø	A	B ⁽¹⁾	high	low	fixed part	
T1	F	1	15	5	8.5	15	8.5	7	9	R	-	-	S
T2	F-P	1	20	4	8.5	20	8.5	6	9	R	-	-	S
T3	F-P	1	20	6	10	20	10	8	18	R	-	-	S
T4	F	1	20	10	10	20	10	18	18	R	-	-	S
	P-W	1	20	10	8	20	8	-	9	-	-	R	R
T5	F	2	30	7	11	30	11	28	18	R	-	-	S
	P-W	2	30	15	10	30	10	-	18	-	-	R	R ⁽⁷⁾
T6 630	F-W	2	40	5	11 ⁽²⁾	40	11 ⁽²⁾	9	18	R	R	R	R
T6 800	F-W	2	50	5	14	50	14	9	30	-	R	R	R
T6 1000	F	2	50	6	14	50	14	9	30	-	-	-	-
T7 1250 ⁽³⁾	F-W	2	50	8	4x11 ⁽⁴⁾	-	-	18 ⁽⁵⁾	40 ⁽⁶⁾	-	R	-	S
T7 1600	F-W	2	50	10	4x11 ⁽⁴⁾	-	-	18 ⁽⁵⁾	40 ⁽⁶⁾	-	R	-	S

⁽¹⁾ class 4.8 screws (not supplied)

⁽²⁾ 14 mm for W

⁽³⁾ up to 1250 A

⁽⁴⁾ only use two holes diagonally

⁽⁵⁾ 12 Nm onto fixed part of withdrawable circuit-breaker

⁽⁶⁾ class 8.8 screws (not supplied)

⁽⁷⁾ Standard for T5 630

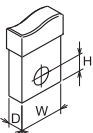

A = Tightening the terminal onto the circuit-breaker

B = Tightening the cable/busbar onto the terminal

R = On request

S = Standard

Pieces = Number of busbars, cables or cable terminals

Front extended spread terminals - ES

Allow connection of busbars or cables terminated with cable terminal



Type	Version	Pieces	Busbars [mm]			Cable terminal [mm]		Tightening [Nm]		Terminal covers			Phase separators
			W	P	Ø	W	Ø	A	B ⁽¹⁾	high	low	fixed part	
T2	F-P	1	30	4	10.5	30	10.5	6	18	-	-	-	S
T3	F-P	1	30	4	10.5	30	10.5	8	18	-	-	-	S
T4	F	1	30	6	10.5	30	10.5	18	18	-	-	-	S
T5	F-P ⁽²⁾ -W ⁽²⁾	1	40	10	11	11	11	28	18	-	-	-	S
T6	F	1	80	5	3 x 13	3 x 45	13	9	30	-	-	-	-
T7	F	2	50	10	3x13	4x45	13	18	40	-	-	-	S
	W	2	80	6	3x13	4x45	13	40	40	-	-	-	-

⁽¹⁾ class 4.8 screws (not supplied)

⁽²⁾ for T5 630 only



Front terminals for copper cables - FC Cu

Allow connection of bare copper cables directly to the circuit-breaker



Type	Assembly	Version	Pieces	Cable [mm ²]		Flexible busbars W x S x N ⁽¹⁾	Tightening [Nm]		Ø [mm]	Terminal covers			Phase separators
				rigid	flexible		A	B		high	low	fixed part	
T1/T1 1p	standard	F	1	2.5...70	2.5...50	9x0.8x6	-	7	12	R	R	-	R
	standard	F	2	-	2.5...35	-	-	7	12	R	R	-	R
T2	standard	F-P	1	1...95	1...70	13x0.5x10	-	7	14	R	R	R	R
	standard	F-P	2	-	1...50	-	-	7	14	R	R	R	R
T3	standard	F-P	1	6...185	6...150	15.5x0.8x10	-	10	18	R	R	R	R
	standard	F-P	2	-	6...70	-	-	10	18	R	R	R	R
T4	standard	F-P-W	1	2.5...185	2.5...120	15.5x0.8x10	-	10	18	R	R	S	R
	standard	F-P-W	2	-	2.5...95	-	-	10	18	R	R	S	R
T5	standard	F-P-W	1	16...300	16...240	24x1x10	-	25	28	R	R	S	R
	standard	F-P-W	2	-	16...150	-	-	25	28	R	R	R	-
	external	F	2	120...240	-	-	18	25	-	S	-	-	-

⁽¹⁾ W = width; S = thickness; N = n. of bars

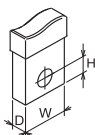

A = Tightening the terminal onto the circuit-breaker
 B = Tightening the cable/busbar onto the terminal
 R = On request
 S = Standard
 Pieces = Number of busbars, cables or cable terminals

Accessories

Connection terminals

Front terminals for copper/aluminium cables - FC CuAl

Allow connection of bare copper or aluminium cables directly to the circuit-breaker (solid aluminium cables cannot be used)



T2-T5
Standard



T4-T5
External

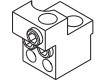

T6-T7

Type	Assembly	Version	Pieces	Cable [mm ²]		Tightening [Nm]		Ø [mm]	Terminal covers			Phase separators
				rigid		A	B		high	low	fixed part	
T1	external	F	1	2.5...50		7	5.6	9.9	S	-	-	-
T1	external	F	1	35...95		7	13.5	14	S	-	-	-
T2	standard	F-P	1	1...95		-	7	14	R	R	R	R
	external	F-P	1	70...185		6	25	18	S	-	S	-
	external	F-P	2	35...95		6	12	16	S	-	S	-
T3	standard	F-P	1	70...185		-	16	18	R	-	R	R
	external	F-P	1	150...240		8	40	24	S	-	S	-
	external	F-P	2	35...150		8	16	18	S	-	S	-
T4	standard	F-P-W	1	6...185		9	31	18	R	R	S	R
	external	F	2	35...150		18	16	18	S	-	S	-
	external	F	1	150...240		18	40	24	S	-	-	-
	standard	F	1	2.5...50		9	5.6	9.9	R	R	R	R
T5	external	F-P-W	1	120...240		18	43	21.5	R	R	R	S
	standard	F-P-W	1	185...300		18	43	24.5	R	R	S	R
	external	F	2	95...240		18	31	24.5	S	-	S	-
	external	F	2	95...120		18	31	-	S	-	-	R
T6 630	standard	F	2	120...240		5	31	21.5	R	-	-	R
T6 800	external	F	3	70...185		9	43	19	S	-	-	-
T6 1000	external	F	4	70...150		9	43	19	S	-	-	-
T7 630	standard	F	2	185...240		18	43	21.5	-	S	-	R
T7 1250 ⁽¹⁾	external	F	4	70...240		18	43	21.5	S	-	-	-

⁽¹⁾ up to 1250 A



Multi-cable terminals - MC

Allow connection of cables directly to the circuit-breaker



Type	Version	Pieces	Cable [mm ²]		Tightening [Nm]		Terminal covers			Phase separators	
			max	flexible	rigid	A	B	high	low		fixed part
T4	F	6	2.5...25	2.5...25	2.5...35	18	7	S	-	-	-
T5	F	6	-	-	16...50	18	5	S	-	-	-

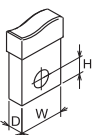

A = Tightening the terminal onto the circuit-breaker
 B = Tightening the cable/busbar onto the terminal
 R = On request
 S = Standard
 Pieces = Number of busbars, cables or cable terminals

Rear terminals for copper/aluminium cables - RC CuAl

Allow connection of bare copper or aluminium cables directly to the circuit-breaker

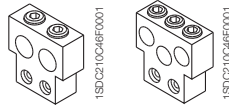

Type	Version	Pieces	Cable		Tightening [Nm]		Ø [mm]	Terminal covers	
			rigid		A	B		high	low
T6 630	F	2	150...240		9	43	21	S	-
T6 800	F	3	70...185		9	31	17,5	S	-

Rear flat horizontal terminals - HR

Allow connection of busbars or cable terminal at the rear. They can only be installed horizontally.

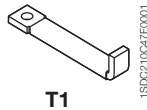

Type	Version	Pieces	Busbars [mm]			Cable terminal [mm]		Tightening [Nm]		Terminal covers		Phase separators
			W	D	Ø	W	Ø	A	B ⁽¹⁾	high	low	
T1	F	1	14	5	6.2	14	6.2	7	5	-	S	-
T7 1250⁽²⁾	F	2	50	8	2x11	-	-	20	40	-	S	-
T7 1600	F	2	50	10	2x11	-	-	20	40	-	S	-

⁽¹⁾ class 8.8 screws (not supplied)

⁽²⁾ up to 1250 A

Rear flat vertical terminals - VR

Allow connection of busbars or cable terminal at the rear. They can only be installed vertically.

Type	Version	Pieces	Busbars [mm]			Cable terminal [mm]		Tightening [Nm]		Terminal covers		Phase separators
			W	D	Ø	W	Ø	A	B ⁽¹⁾	high	low	
T7 1250⁽²⁾	F	2	50	8	2x11	-	-	20	40	-	S	-
T7 1600	F	2	50	10	2x11	-	-	20	40	-	S	-

⁽¹⁾ class 8.8 screws (not supplied)

⁽²⁾ up to 1250 A

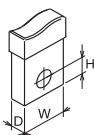

A = Tightening the terminal onto the circuit-breaker
 B = Tightening the cable/busbar onto the terminal
 R = On request
 S = Standard
 Pieces = Number of busbars, cables or cable terminals

Accessories

Connection terminals

Rear flat horizontal terminals for RC221/RC222 - HR

Allow connection of busbars or cable terminal at the rear with RC221/RC222.
They can be installed horizontally

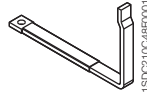

Type	Version	Pieces	Busbars [mm]			Tightening [Nm]		Terminal covers		Phase separators
			W	D	Ø	A	B	high	low	
T1	F	1	14	5	6.2	7	5 ⁽¹⁾	-	-	-

⁽¹⁾ class 8.8 screws (not supplied)

Rear terminals - R

Allow connection of busbars or cable terminal at the rear.
They can be installed in 4 different positions to facilitate connection to cable/busbars

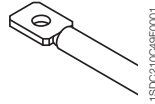

Type	Version	Pieces	Busbars [mm]			Tightening [Nm]		Terminal covers		Phase separators
			W	D	Ø	A	B ⁽¹⁾	high	low	
T2	F-P	1	20	4	8.5	6	9	-	S	-
T3	F-P	1	20	6	8.5	6	9	-	S	-
T4	F	1	20	10	8.5	6	9	-	S	-
T5	F	2	30	7	11	18	18	-	S	-
T6 630	F	2	40	5	14	18	30	-	S	-
T6 800	F	2	50	5	14	18	30	-	S	-
T6 1000	F	2	50	6	14	18	30	-	S	-
T7 1250⁽²⁾	F	2	50	8	2x11	20	40	-	S	-
T7 1600	F	2	50	10	2x11	20	40	-	S	-

⁽¹⁾ class 8.8 screws (not supplied)

⁽²⁾ up to 1250 A



Rear spreaded terminals - RS

Allow connection of busbars and cable terminal at the rear.

Type	Version	Pieces	Busbars [mm]			Tightening [Nm]		Terminal covers			Phase separators
			W	D	Ø	A	B	high	low	fixed part	
T7	W	2	60	10	2x11	18	40	-	-	-	-

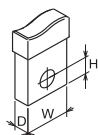

A = Tightening the terminal onto the circuit-breaker
B = Tightening the cable/busbar onto the terminal
R = On request
S = Standard
Pieces = Number of busbars, cables or cable terminals

Rear flat horizontal and vertical terminals for fixed parts - HR/VR

These allow connection of busbars or cable terminals at the rear.
There are rear horizontal or vertical terminals.

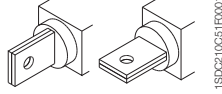

Type	Version	Pieces	Busbars [mm]			Cable terminal [mm]		Tightening [Nm]		Terminal covers			Phase separators
			W	D	Ø	W	Ø	A	B ⁽¹⁾	high	low	fixed part	
T4	P - W	1	20	10	10	20	10	6	18	-	-	-	-
T5 400	P - W	1	25	10	12	25	12	9	18	-	-	-	-
T5 630	P - W	2	40	15	11	40	11	-	18	-	-	-	-
T6 630	W	2	40	5	14	40	14	-	30	-	-	-	-
T6 800	W	2	50	5	14	50	14	-	30	-	-	-	-
T7 1250 ⁽²⁾⁽³⁾	W	2	50	8	2x11	-	-	12	40	-	-	-	-
T7 1600 ⁽³⁾	W	2	50	10	2x11	-	-	12	40	-	-	-	-

⁽¹⁾ class 4.8 screws (not supplied)

⁽²⁾ up to 1250 A

⁽³⁾ for vertical assembly directly in the factory, use extra code 1SDA063571R1

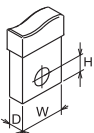

A = Tightening the terminal onto the circuit-breaker
B = Tightening the cable/busbar onto the terminal
R = On request
S = Standard
Pieces = Number of busbars, cables or cable terminals

Accessories

Service releases

The Tmax family of circuit-breakers can be fitted with service releases (shunt opening release, shunt closing release and undervoltage release). These are available in the pre-cabled version, depending on the size of the circuit-breaker fitted with 1 m long free cables, with a connector with 1 m cables or with a simple pin connector and two terminals to be mounted in the terminal board, or in the uncabled version, with cabling to be carried out by the customer.

Assembly is carried out for all the releases by pressing into the special seat in the left part of the circuit-breaker (right for T7) and fixing with the screw provided.

The releases are always alternative to each other for T1, T2, T3 (both for the three-pole and four-pole version), whereas for T4, T5 and T6 in the four-pole version the shunt opening release (not possible with PS-SOR) and the undervoltage release can be housed at the same time, as long as they are in the wired version and with the shunt opening release necessarily mounted in the slot of the third pole. T4, T5, T6 circuit-breakers in the withdrawable version can be equipped only with pre-cabled accessories; the T4-T5-T6 circuit-breakers complete with motorized controls can only be fitted with prewired undervoltage and shunt opening releases.

The T7 circuit-breaker allows simultaneous mounting of all three service releases. These two possibilities are available on the three-pole version as well. Moreover Tmax T7 can be equipped with two shunt opening releases instead of the undervoltage release to facilitate some specific applications where a very high safety level of the remote circuit-breaker opening command is required.

Shunt opening release – SOR

Allows circuit-breaker opening by means of an electric command. Operation of the release is guaranteed for a voltage between 70% and 110% of the rated power supply voltage value U_n , both in alternating current and in direct current. For Tmax T1, T2, T3, T4, T5 and T6, the SOR shunt opening release is fitted with a limit contact for cutting off the power supply in the open position and with the release tripped.



1SDC210C55F0001

T1-T2-T3



1SDC210C55F0001

T4-T5-T6



1SDC210D18F0001

T7

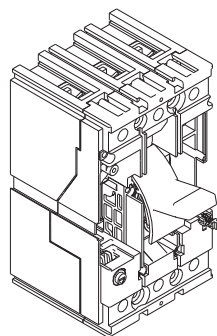

T1-T2-T3

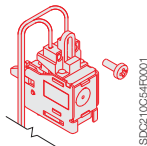

1SDC210C55F0001

T4-T5-T6

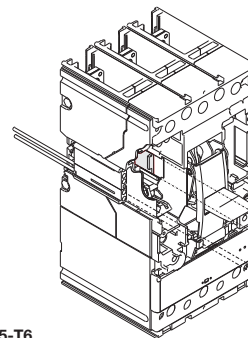

1SDC210C55F0001

SOR - Electrical characteristics

Version	Inrush power consumption					
	Tmax T1, T2, T3		Tmax T4, T5, T6		Tmax T7	
	AC [VA]	DC [W]	AC [VA]	DC [W]	AC [VA]	DC [W]
12 V DC		50		150		
24 V AC/DC					300	300
24...30 V AC/DC	50	50	150	150		
30 V AC/DC					300	300
48 V AC/DC					300	300
48...60 V AC/DC	60	60	150	150		
60 V AC/DC					300	300
110...120 V AC/DC					300	300
120...127 V AC/DC					300	300
110...127 V AC - 110...125 V DC	50	50	150	150		
220...240 V AC/DC					300	300
220...240 V AC - 220...250 V DC	50	50	150	150		
240...250 V AC/DC					300	300
380...400 V AC					300	
380...440 V AC	55		150			
415...440 V AC					300	
480...525 V AC	55		150			
Opening times [ms]	15	15	15	15	50	50

Shunt opening release with permanent service – PS-SOR

Furthermore, for T4, T5 and T6, opening coils with permanent service (PS-SOR) are available, with much lower power consumption and which can be supplied continuously: in this case, in fact, they are not fitted with auxiliary limit contact. The pre-cabled or uncabled version can be chosen for these coils as well.

PS-SOR - Electrical characteristics

Version	Tmax T4, T5, T6	
	AC [VA]	DC [W]
24 V AC/DC	4	4
110...120 V AC	4	-



1SDC210C35FF0001

SOR Test Unit

The SOR Test Unit - control/monitoring unit - allows correct operation of the shunt opening releases which can be mounted on the Tmax from T1...T7 circuit-breaker to be verified, to guarantee a high level of reliability for the circuit-breaker opening command.

The SOR Test Unit - control/monitoring unit - allows continuity of the shunt opening releases with a rated service voltage between 24 V and 250 V (AC and DC) to be verified, as well as operation of the electronic circuit of the opening coil. The check of continuity is carried out cyclically at an interval of 20 seconds between one test and the next.

The unit has LED optic signals on the front which provide the following information:

- POWER ON: presence of power supply
- YO TESTING: test being carried out
- TEST FAILED: indication following a failed test or lack of auxiliary power supply
- ALARM: signalling after three failed tests.

There are also two relays and a changeover switch available on board the unit which allow the following two events to be signalled remotely:

- failure of a test (resetting takes place automatically when the alarm goes off)
- failure of three tests (resetting only takes place by means of the manual RESET from the front of the unit).

Characteristics	
Auxiliary power supply	24 V...250 V AC / DC
Maximum interrupted current	6 A
Maximum interrupted voltage	250 V AC



1SDC210D18FC001

T7

Shunt closing release – SCR

The shunt closing release - only available on the motorizable versions of Tmax T7 - allows remote closure of the circuit-breaker when the circuit-breaker closing springs are charged. The technical characteristics and the service voltages of the shunt closing release are identical to those of the shunt opening release available on T7. The closing time of the circuit-breaker by means of SCR is 50 ms. Thanks to the anti-surge system, the closure of the circuit-breaker is not possible before the opening operation has entirely been performed. Thus a delay of at least 30 ms between the opening and closing command is required.

Accessories

Service releases

Undervoltage release – UVR

Opens the circuit-breaker due to lack of release power supply voltage or to drops to values under $0.7 \times U_n$ with a trip range from 0.7 to $0.35 \times U_n$. After tripping, the circuit-breaker can be closed again starting from a voltage higher than $0.85 \times U_n$. With the undervoltage release de-energised, it is not possible to close the circuit-breaker or the main contacts.

UVR - Electrical characteristics UVR T1...T6

Version	Power consumption during permanent operation			
	Tmax T1, T2, T3		Tmax T4, T5, T6	
	AC [VA]	DC [W]	AC [VA]	DC [W]
24 V AC/DC				
24...30 V AC/DC	1.5	1.5	6	3
30 V AC/DC				
48 V AC/DC	1	1	6	3
60 V AC/DC	1	1	6	3
110...120 V AC/DC				
120...127 V AC/DC				
110...127 V AC - 110...125 V DC	2	2	6	3
220...240 V AC/DC				
220...240 V AC - 220...250 V DC	2.5	2.5	6	3
240...250 V AC/DC				
380...400 V AC				
380...440 V AC	3		6	
415...440 V AC				
480...525 V AC	4		6	
Opening times [ms]	15	15	≤ 25	≤ 25



T1-T2-T3



T4-T5-T6



T7

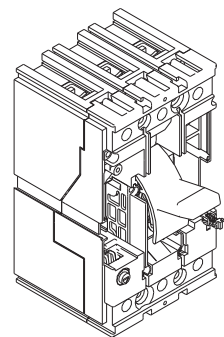

T1-T2-T3

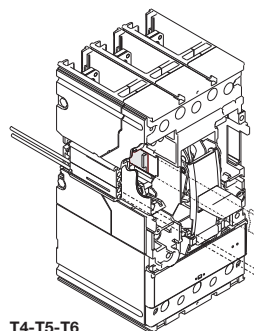
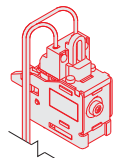

T4-T5-T6

UVR - Electrical characteristics UVR T7

Characteristics		
Power supply (U_n)	24 V AC/DC	240-250 V AC/DC
	30 V AC/DC	380-400 V AC
	48 V AC/DC	415-440 V AC
		60 V AC/DC
		110-120 V AC/DC
		120...127 V AC/DC
Operating limits	IEC EN 60947-2 Standards	
	Inrush power (P_s)	DC = 300 W
	Inrush time ~ 100 ms	AC = 300 VA
	Continuous power (P_c)	DC = 3.5 W
	AC = 3.5 VA	
Opening time (UVR)	30 ms	
Insulation voltage	2500 V 50 Hz (for 1 min)	



1SDC2100C61F0001

Time delay device for undervoltage release – UVD

The undervoltage release (UVR) can be combined with an external electronic power supply time delay device, which allows circuit-breaker opening to be delayed in the case of a drop or failure in the power supply voltage of the release itself, according to preset and adjustable delays, in order to prevent unwarranted trips caused by temporary malfunctions. The delay device must be combined with an undervoltage release with the same corresponding voltage.

Two time delay devices with the same characteristics are available. For T1-T6 a time delay device which can be combined also on the Isomax S3-S4-S5 circuit-breakers is available. The time delay device for Tmax T7 is the one already available on the Emax ranges.

UVD

Circuit-breaker	Power supply voltage [V AC/DC]
T1...T6	24...30
T1...T6	48...60
T1...T6	110...125
T1...T6	220...250
Delay which can be set [s]	0.25 - 0.5 - 0.75 - 1 - 1.25 - 2 - 2.5 - 3
Trip time tolerance	± 15%

Circuit-breaker	Power supply voltage [V AC/DC]
T7	24...30
T7	48
T7	60
T7	110...125
T7	220...250
Delay which can be set [s]	0.5 - 1 - 1.5 - 2 - 3



1SDC2100C61F0001

Testing extension for service releases

Available for Tmax T4, T5 and T6, this allows the service releases to be supplied with the circuit-breaker in the removed position. With the circuit-breaker in safe conditions, i. isolated in relation to the power circuits, this makes it possible to carry out blank tests of the circuit-breaker functionality.

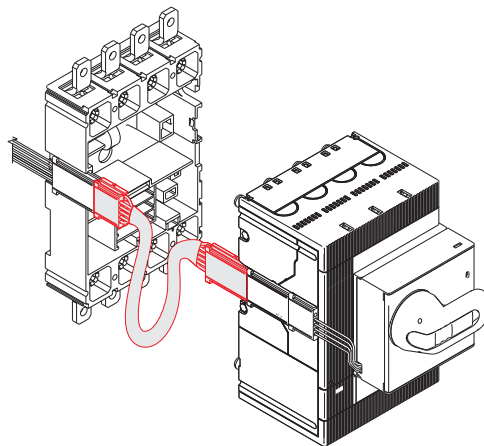

1SDC2100C61F0001

Accessories

Electrical signals

These allow information on the operating state of the circuit-breaker to be taken outside. Installation of these accessories is carried out directly from the front of the circuit-breaker in special slots placed on the right-hand side of the circuit-breaker, completely segregated from the live parts - all to the benefit of user safety. The auxiliary contacts can be supplied (depending on the type) either in the version with cabling to be carried out by the customer by means of connection to the terminals integrated in the auxiliary contacts, or with cabling directly on the circuit-breaker terminal board or in the pre-cabled version, depending on the size of the circuit-breaker fitted with free cables 1 m long, with a connector with 1 m long cables. The pre-cabled version is mandatory on the T4, T5 and T6 circuit-breakers in the withdrawable version. The auxiliary contacts for T7 are always fitted with three terminals to be mounted in the terminal board to carry out the cabling. The auxiliary contacts are available for use both in direct and alternating current at various voltages. The signals are reset when the circuit-breaker is reset.

T1-T7 (AUX)

Available both in the pre-cabled and uncabled version, they supply the following electrical signalling:

- open/closed: indicates the position of the circuit-breaker contacts (Q)
- release trip: signals circuit-breaker opening due to overcurrent release trip (for overload or short circuit), trip of the residual current release, of the opening coil or of the undervoltage release, of the emergency opening pushbutton of the motor operator or two to operation of the test pushbutton (SY)
- contact for signalling electronic trip unit tripped: signals intervention of one of the protection functions of the electronic trip unit (S51).

The auxiliary contacts for T7 are always fitted with terminals to be mounted in the terminal box to carry out wiring.

T4, T5, T6 and T7 with electronic trip units (AUX-SA)

There is a contact for signalling electronic trip units tripped, only available in the pre-cabled version for use at 250 V AC.

T4, T5 and T6 (AUX-MO)

This auxiliary contact, only in the cabled version, must necessarily be combined with the motor operator and indicates the motor operation mode (manual or remote).

T7 (AUX-RTC)

The "circuit-breaker ready to close" auxiliary contact is available with wiring directly on the terminal box of the T7 circuit-breaker with stored energy operating mechanism and signals that the circuit-breaker is ready to accept a closing command if there are the following five conditions:

- circuit-breaker open
- closing springs charged
- any opening coil de-energised
- any undervoltage coil energised
- opening solenoid armed.

T7 (AUX-SC)

Indicates the state of the circuit-breaker operating mechanism closing springs remotely (supplied only with the spring charging motor).

T4, T5 and T6 with PR222DS/PD, PR223DS and PR223EF electronic trip unit (AUX-E)

Only available in the pre-cabled version, the auxiliary contacts AUX-E (also called electronic version contacts) communicate the state of the circuit-breaker to the electronic trip unit and make an open/closed signal available to the outside and another one for electronic trip unit tripped.

They can only be combined with the PR222DS/PD or PR223DS electronic trip unit and only function when there is a 24 V DC auxiliary power supply to the trip unit for the communication functions.

The AUX-E contacts can, moreover, be directly connected to the MOE-E motor operator (see page 3/26).

The "traditional" version of the auxiliary contacts can also be combined with the protection trip units with dialogue; in this case, only electrical signalling of the state of the circuit-breaker will be provided and it will not be possible to communicate remotely or control the motor.



1SDC210038F0001

AUX - 250 V AC/DC



1SDC210038F0001

AUX-C - 250 V AC/DC

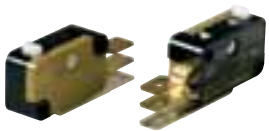

1SDC210019F0001

T7

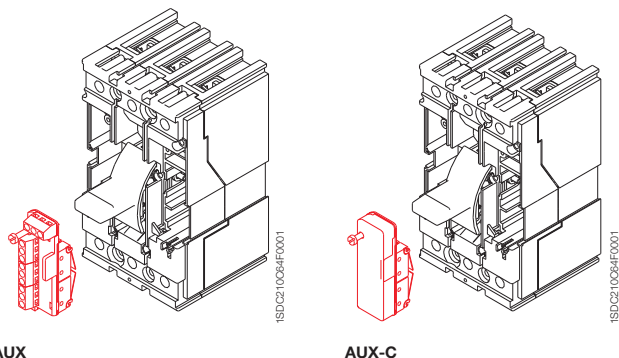

AUX - Electrical characteristics

AUX 250 V - T1...T6

Power supply voltage

125 V
250 V
Protection with gG 10x38 type fuse (I _{max} 6 A)

Service current

Category of utilisation (IEC 60947-5-1)

AC 14	DC 13
6 A	0.3 A
5 A	0.15 A

AUX 400 V - T4...T7

Power supply voltage

125 V
250 V
400 V

Service current I_n [A]

AC	DC
-	0.3
12 ⁽¹⁾	0.15
3	-

⁽¹⁾ 5 A for T_{max} T7

AUX 24 V - T1...T7

Power supply voltage

24 V
5 V

Service current I_n [A]

AC	DC
-	≥ 0.75 mA
-	≥ 1 mA

AUX-E - T4...T6

Typical contact	Mosfet
V _{max}	48 V DC/30 V AC
R _{max}	35 ohm
P _{max} (resistive load)	200 mW
System contact/earth insulation	2000 V AC (1 min. @ 50 Hz)
Contact/contact insulation	400 V DC

Table of the possible combinations of the T7-T7M auxiliary contacts

T7	SY	Q1			1Q + 1SY	T7M			Q2	Q3	2Q
			Q2	Q3	2Q		Q4	Q1			2Q
	SY	Q1	Q2	Q3	3Q + 1SY		Q4	Q1	Q2	Q3	4Q

Accessories

Electrical signals

Types of auxiliary contacts

		Version	T1	T2 TMD	T2 PR221	T3	T4	T5	T6	T7
AUX 250 V AC/DC	1 open/closed changeover contact + 1 release tripped changeover contact	pre-cabled/ not cabled	■	■		■	■	■	■	
AUX 250 V AC/DC	3 open/closed changeover contacts + 1 release tripped changeover contact	pre-cabled/ not cabled	■	■		■	■	■	■	
AUX 250 V AC/DC	1 SA electronic release trip contact + 1 open/closed changeover contact + 1 release tripped changeover contact	pre-cabled			■					
AUX 250 V AC/DC	2 open/closed changeover contacts + 1 release tripped changeover contact	pre-cabled			■					
AUX 400 V AC	1 open/closed changeover contact + 1 release tripped changeover contact	pre-cabled					■	■	■	■
AUX 400 V AC	2 open/closed changeover contacts	pre-cabled					■	■	■	■
AUX 24 V DC	1 open/closed changeover contact + 1 release tripped changeover contact	pre-cabled								■
AUX 24 V DC	2 open/closed changeover contacts	pre-cabled								■
AUX 24 V DC	3 open/closed changeover contacts + 1 release tripped changeover contact	pre-cabled/ not cabled	■	■		■	■	■	■	
AUX-SA 250 V AC	1 SA electronic release trip contact	pre-cabled					■	■	■	■
AUX-MO	1 contact signalling manual/remote	not cabled					■	■	■	
AUX-RTC 24 V DC	1 contact signalling ready to close	pre-cabled								■
AUX-RTC 250 V AC/DC	1 contact signalling ready to close	pre-cabled								■
AUX-SC 24 V DC	1 contact signalling closing springs charged	pre-cabled								■
AUX-SC 250 V AC/DC	1 contact signalling closing springs charged	pre-cabled								■
AUX-E	1 open/closed contact + 1 relay tripped contact (only with PR222DS/PD and PR223DS)	pre-cabled					■	■	■	



1SDC210036F0001

Testing extension for auxiliary contacts

Available for Tmax T4, T5 and T6 circuit-breakers, this allows the auxiliary contacts to be connected to the relative power supply circuit with the circuit-breaker in the removed position. With the circuit-breaker in a safe position, i.e. isolated in relation to the power circuits, it is possible to carry out blank function tests of the circuit-breaker.

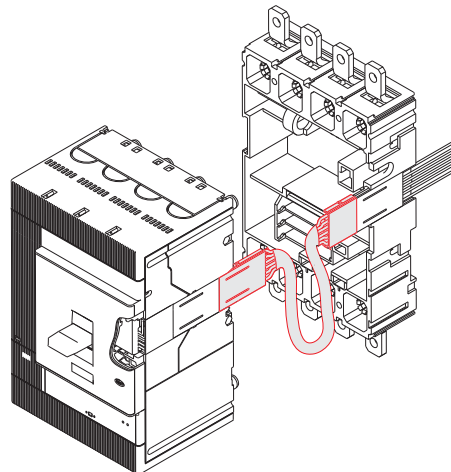

1SDC210065F0001



1SDC210C89F0001

Early auxiliary contacts – AUE

Normally open contacts, advanced in relation to closing (2 contacts for all the sizes, except for T7 where there are 3). They allow the undervoltage release to be supplied in advance, in relation to closing of the main contacts, in compliance with the IEC 60204-1 and VDE 0113 Standards. They are mounted inside the direct and transmitted rotary handle operating mechanism, whereas on T7 with lever operating mechanism, they are mounted directly on the circuit-breaker. The early contacts are only supplied in the cabled version with 1 m long cables, complete with socket-plug with 6 poles for T1, T2 and T3 or with socket-plug connectors with 1 m. cables for T4, T5 and T6. It is necessary to bear in mind that the connectors for T4, T5 and T6, once inserted in the special slot on the left-hand side of the circuit-breaker, extend in relation to the outline of the circuit-breaker itself. The early auxiliary contacts for T7 are always fitted with 3 terminals to be mounted in the terminal board to carry out the cabling.

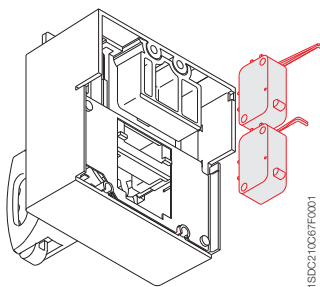

1SDC210C89F0001



1SDC210C89F0001

Auxiliary position contacts – AUP

With Tmax circuit-breakers, auxiliary position contacts which provide electrical signalling of the circuit-breaker position in relation to the fixed part are available. The following auxiliary position contacts are available:

T2 - T3

- contacts signalling circuit-breaker racked-in.

T4 - T5 - T6

- circuit-breaker racked-in signalling contacts for plug-in and withdrawable versions
- circuit-breaker racked-out signalling contacts only for withdrawable version
- circuit-breaker racked-in signalling contacts for plug-in and withdrawable versions 24 V DC
- circuit-breaker racked-out signalling contacts only for withdrawable version 24 V DC.

T7

- contacts for signalling circuit-breaker racked-in
- contacts for signalling circuit-breaker in isolated-test
- contacts for signalling circuit-breaker racked-out.



1SDC210D20F0001

T7

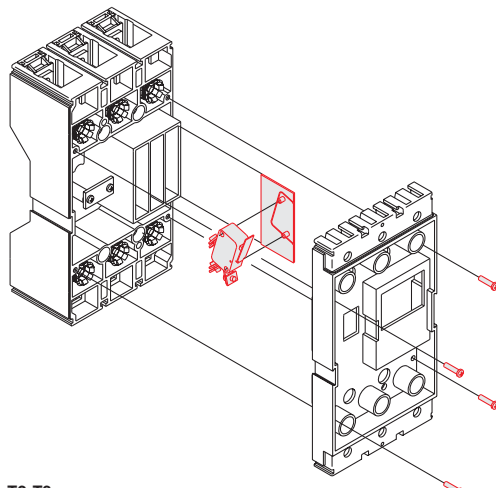

T2-T3

1SDC210C89F0001

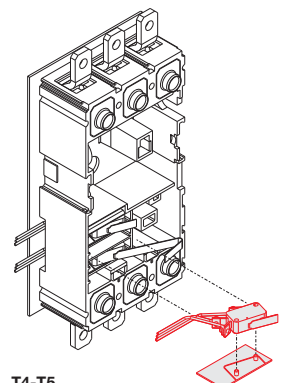

T4-T5

1SDC210C70F0001

Accessories

Electrical signals

A maximum of three contacts can be installed on the fixed part of T2, T3, T4 and T5, whereas up to five auxiliary contacts can be mounted on the fixed part of T6 in all the combinations (for T4 and T5, in the withdrawable version, only one contact for signalling circuit-breaker racked-out can be housed in the compartment closest to the bottom terminals).

The auxiliary contacts for T7 are inserted in a single block consisting of two contacts for signalling racked-in, two for isolated-test and two for racked-out.



1SDC210W8F001

Trip reset

Available on T7 in the version with possibility of motorisation, this is a coil which allows remote circuit-breaker resetting following a trip of the overcurrent releases. It is available with two power supply voltages: 24...30 V AC/DC, 110...130 V AC/DC and 200...240 V AC/DC.



1SDC210D2ZF001

Mechanical operation counter

Available on T7 motorizable, it is connected to the operating mechanism by means of a simple lever mechanism. It indicates the number of circuit-breaker mechanical operations. The indication is visible from the outside on the front of the circuit-breaker.

Accessories

Remote control



1SDC210C71R001



1SDC210C72F001

Solenoid operator for T1, T2 and T3 – MOS

Allows remote circuit-breaker opening and closing control and is particularly recommended for use in electric network supervision and control systems. A selector allows passage from automatic to manual operation and it is also available a block (supplied as standard) for the operating mode of the motor. It is always provided with a padlock in the open position which prevents any command, either locally or remotely. It operates both circuit-breaker opening and closing, working directly on the circuit-breaker lever.

It is offered in two versions, one “side-by-side” with the circuit-breaker, with T1 and T2, for installation on a panel or DIN EN 50022 rail, the other on the “front”, with T1, T2 and T3, suitable for installation directly on the front of the circuit-breaker.

The latter is complete with operating handle. The front version can also be used with plug-in circuit-breakers.

Coupling with the residual current release is only allowed for a circuit-breaker with solenoid operator side-by-side, to allow access to the user interface of the residual current release from the front of the switchgear. In fact, using the solenoid operator superimposed would imply the circuit-breaker position on the rear of the door and its residual current release and the interface would no longer be accessible. This combination can only be installed directly on the back plate of the switchgear. Both versions can be used either in the three-pole or four-pole version. The solenoid operator is supplied complete with 1 m long cables and, just for the superimposed version, with a socket-plug connector with 5 poles.

Both the opening and closing commands are operated by the solenoid which acts directly on the circuit-breaker lever. The solenoid operator functions are also guaranteed thanks to permanent opening/closing electric power.

The main parameters relative to the solenoid operator are indicated in the table.

Rated voltage, Un		
AC	[V]	110...250
DC	[V]	48...60 / 110...250
Operating voltage		85...110% Un
Inrush power consumption during operation		1800 [VA] / 1000 [W]
Power on stand-by		< 100 [mW]
Time	opening [s]	< 0.1
	closing [s]	< 0.1
Mechanical life	[No. operations]	25000
	[No. operations/h]	240 (T1 and T2); 120 (T3)
Degree of protection, on the front		IP30
Minimum control impulse time on opening and closing	[ms]	>100

The unit is permanently supplied on stand-by, a control is applied by means of an external contact (relay, opto-insulator) in a low power circuit.
 Contact characteristics: V AC/DC = 24 V
 I AC/DC = 50 mA

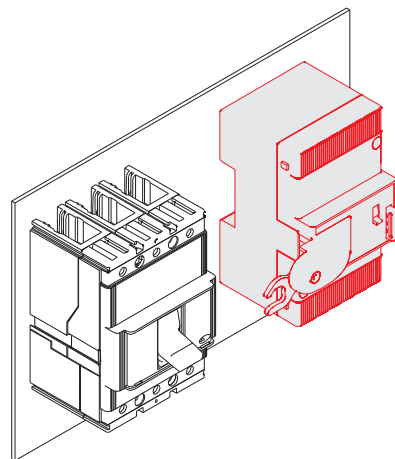

1SDC210C73R001

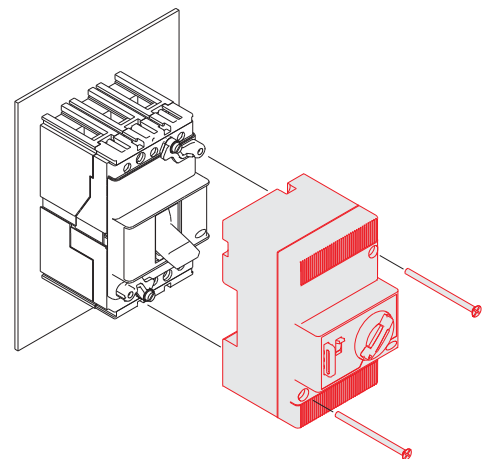

1SDC210C74R001

Accessories

Remote control



1SDC210C75F0001

Stored energy motor operator for T4, T5 and T6 – MOE and MOE-E

With the stored energy motor operator, it is possible to control both opening and closing of the circuit-breaker on which it is installed. During opening of the circuit-breaker, the spring system is recharged automatically: the stored energy is exploited in this way to close the circuit-breaker.

The motor operator is always supplied with socket-plug connectors with 1 m long cables and is always fitted with a padlock in the open position, which prevents any command, either locally or remotely. The connectors, once inserted in the special slot on the left-hand side of the circuit-breaker, extend in relation to the outline of the circuit-breaker itself and are only compatible with pre-wired electrical accessories. A selector allows passage from automatic to manual operation and it is also available as a block (supplied as standard) for the operating mode of the motor.

The motor operator can be fitted both with a key lock in the open position (with the same MOL-S keys for groups of circuit-breakers or different MOL-D keys) and with an MOL-M key lock against manual operation: in the former case, the lock in the open position is both of electrical and mechanical type, in the latter case, only of mechanical type, i.e. only closing from the front of the circuit-breaker (remote closing is allowed).

In the case of interlocked circuit-breakers, for safety reasons the key lock against manual operation is required.

The motor operator is always fitted with a contact to signal “auto” or “manual” (not on changeover). On request, it can also be fitted with an AUX-MO auxiliary contact (on changeover), which provides a signal of its state of service: “auto” (remote control of the circuit-breaker) or “manual”.

If the circuit-breaker is fitted with the PR222DS/PD and PR223DS electronic trip unit, instead of the MOE motor operator, it is possible to use the MOE-E motor operator: for its use, the circuit-breaker must also be fitted with the AUX-E auxiliary contacts (standard supply with MOE-E). The MOE-E allows use of the digital signals coming from the supervision and control system, by means of the PR222DS/PD, PR223DS and PR223EF trip unit and the AUX-E contacts, and to convert these into power signals to operate the motor operator. All the characteristics indicated above for the MOE motor operator are also valid for the MOE-E. The motor operator functions are also guaranteed thanks to permanent opening/closing electric power.

The main parameters relative to the stored energy motor operator are indicated in the table.

MOE and MOE-E

	Tmax T4-T5		Tmax T6	
	AC [V]	DC [V]	AC [V]	DC [V]
Rated voltage, Un	-	24	-	24
	-	48...60	-	48...60
	110...125	110...125	110...125	110...125
	220...250	220...250	220...250	220...250
	380	-	380	-
Operating voltage [% Un]	85...110	85...110	85...110	85...110
Power consumption on inrush Ps	≤ 300 VA	≤ 300 W	≤ 400 VA	≤ 400 W
Power consumption in service Pc	≤ 150 VA	≤ 150 W	≤ 150 VA	≤ 150 W
Duration				
opening [s]		1.5		3
closing [s]		< 0.1		< 0.1
resetting [s]		3		5
Mechanical life [No. operations]		20000		10000
Degree of protection, on the front		IP30		IP30
Minimum control impulse time on opening and closing [ms]		≥ 100		≥ 100

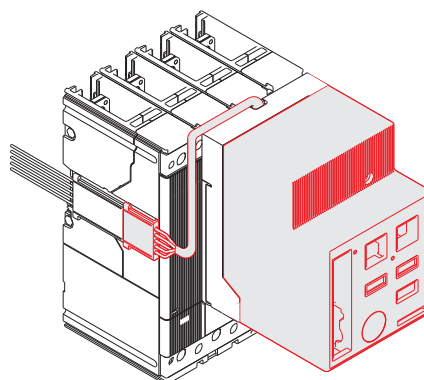

1SDC210C75F0001

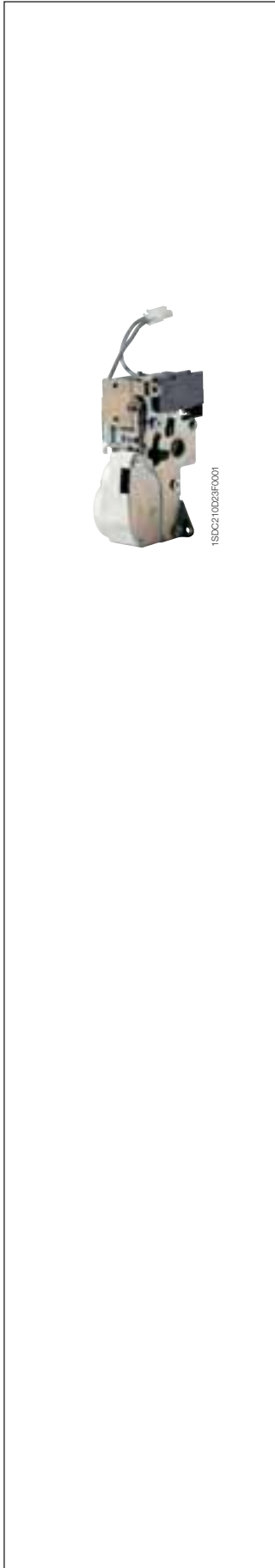

Testing extension for motor operators

Available for circuit-breakers Tmax T4, T5 and T6, this allows the motor operator to be connected to the relative power supply circuit with the circuit-breaker in the removed position. With the circuit-breaker in a safe position, i.e. isolated in relation to the power circuits, it is possible to carry out blank tests of the circuit-breaker functions.

Spring charging motor for T7 motorizable

Only available on Tmax T7 in the motorizable version, it automatically charges the circuit-breaker operating mechanism springs. This operation is carried out automatically immediately after closure of the circuit-breaker.

When there is no power supply or during maintenance work, the closing springs can, in any case, be charged manually by means of the special operating mechanism lever. It is always fitted with limit contact.

The spring charging motor can be fitted with a terminal to be mounted in the terminal board to carry out the cabling.

Spring charging motor

	Tmax T7	
	AC [V]	DC [V]
Rated voltage, Un	24...30	24...30
	48...60	48...60
	100...130	100...130
	220...250	220...250
	380...415	
Opening voltage [% Un]	85...110	85...110
Power consumption	≤ 100 VA	≤ 100 W
Charging time [s]	8 - 10	8 - 10

Note: To allow a complete remote control with T7 motorizable, the circuit-breaker must be fitted with:

- shunt opening release;
- shunt closing release;
- spring charging motor.

Accessories

Remote control

Adapters – ADP

For the SOR, PS-SOR, UVR, AUX, MOE or MOE-E and AUE pre-wired electrical accessories, used with Tmax T4, T5 and T6 in the plug-in or withdrawable version, it is necessary to use the adapters to be coupled with the plug, which will then be connected to the socket on the fixed part, for the moving parts.

According to the electrical accessories required, one or two adapters will be needed to be mounted on the left and/or right side of the moving part.

There are four types adapters available:

- 5-way adapters
- 6-way adapters
- 10-way adapters
- 12-way adapters.

The table below indicates the adapters which have to be used for the various possible combinations of electrical accessories:

Adapters ADP for T4, T5 and T6 wired accessories

	5- way	6- way	10- way	12- way
left side				
SOR	■			
UVR	■			
SA for residual current release RC222	■			
SOR or UVR + SA for residual current release RC222	■			
MOE (MOE-E)			■	
MOE (MOE-E) + SOR or UVR			■	
MOE (MOE-E) + SOR or UVR + SA for residual current release RC222			■	
AUE			■	
AUE + SOR or UVR			■	
AUE + SOR or UVR + SA for residual current release RC222			■	
right side				
AUX 1Q + 1SY 1 open/closed changeover contact + 1 trip unit tripped changeover contact		■		
AUX 2Q 2 open/closed changeover contacts		■		
AUX 3Q + 1SY 3 open/closed changeover contacts + 1 trip unit tripped changeover contact				■

For Tmax T2 and T3 in the plug-in version, it is necessary, on the other hand, to order the socket-plug connectors: with 12 poles for the AUX auxiliary contacts - 3 open/closed changeover + 1 release tripped changeover, with 6 poles for the AUX auxiliary contacts -1 open/closed changeover + 1 release tripped changeover and with 3 poles for the service releases (SOR or UVR).

For T2 in the plug-in version with PR221 electronic trip unit and suitable auxiliary contacts, it is necessary to order a 6 and a 3 pole socket-plug connector.

Socket plug connectors

In order to allow the racking-in and racking-out operations of the moving part of the plug-in circuit-breaker, the wired and unwired electrical accessories of Tmax T2 and T3 and the unwired electrical accessories of Tmax T4, T5 and T6 must be fitted with one or more socket plug connectors, as per the table below.

Socket plug connectors

	3 poles	6 poles	12 poles
T2-T3-T4-T5-T6			
SOR	■		
UVR	■		
AUX 1Q + 1SY 1 open/closed changeover contact + 1 trip unit tripped changeover contact		■	
AUX 2Q 2 open/closed changeover contacts		■	
AUX 3Q + 1SY 3 open/closed changeover contacts + 1 trip unit tripped changeover contact			■
T2-T3			
MOS overload ⁽¹⁾		■	
AUE	■		
AUX 2Q + 1SY for PR221 2 open/closed contacts + 1 trip unit tripped changeover contact	■	■	
AUX 1S51 + 1Q + 1SY for PR221 1 changeover contact + 1 SA electronic release trip contact 1 trip unit tripped changeover contact	■	■	

⁽¹⁾ Always provided with the overlaid solenoid operator

Accessories

Operating mechanism and locks



T4-T6

Rotary handle operating mechanism – RHD/RHE

Thanks to its ergonomic grip, the rotary handle facilitates the circuit-breaker closing and opening operations.

It is always fitted with a padlock-lock in the open position which prevents circuit-breaker closing. The opening in the padlock-lock can take up to 3 padlocks - 7 mm Ø stem (not supplied). It is always fitted with a compartment door lock and on request it can be supplied with a key lock in the open position. Application of the rotary handle operating mechanism is an alternative to the motor operator and to the front interlocking plate (MIF) for T1, T2 and T3, or to the motor operator and to the front for lever operating mechanism for T4, T5 and T6. The rotary handle operating mechanism is available in either the direct version or in the transmitted version on the compartment door and the rotary handle operating mechanism in the emergency version, complete with red on yellow background handle, suitable for controlling machine tools, is available in both the versions.

The rotary handle operating mechanism is available on T7 with lever operating mechanism and, only for the direct version, is characterised by an articulated grip which allows the switchgear door to be opened in case of an emergency with the circuit-breaker closed. The release settings and nameplate data remain accessible to the user.

The transmitted rotary handle operating mechanisms can be ordered by building up the following three devices:

- rotary handle on the compartment door
- transmission rod (500 mm)
- base for circuit-breaker or, alternatively, by using the code of the ready-configured version.

Type of RH_ operating mechanism

		T1		T2, T3		T4, T5			T6		T7 ⁽¹⁾	
		F	F	P	F	P	W	F	W	F	W	
RHD	Direct	■	■	■	■	■	■	■	■	■	■	■
RHD_EM	Emergency direct	■	■	■	■	■	■	■	■	■	■	■
RHE	Transmitted with adjustable distance	■	■	■	■	■	■	■	■	■	■	■
RHE_EM	Emergency transmitted with adjustable distance	■	■	■	■	■	■	■	■	■	■	■
RHE_B	Base for circuit-breaker	■	■	■	■	■	■	■	■	■	■	■
RHE_S	Rod for transmitted adjustable handle	■	■	■	■	■	■	■	■	■	■	■
RHE_H	Handle for transmitted RH with adjustable distance	■	■	■	■	■	■	■	■	■	■	■
RHE_H_EM	Emergency handle for transmitted RH with adjustable distance	■	■	■	■	■	■	■	■	■	■	■

⁽¹⁾ The rotary handle operating mechanism is only available for T7 with lever operating mechanism and it is as an alternative to the key lock mounted on the circuit-breaker.

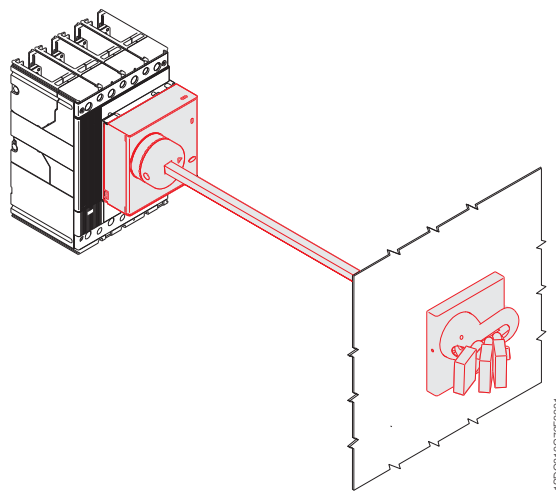

T4-T6



1SDC210C89F0001



1SDC210C81F0001

IP54 protection for rotary handle

Allows IP54 degree of protection to be obtained.

It is available for the transmitted rotary handle operating mechanism on the compartment door (RHE) for all the Tmax circuit-breakers.

Front for lever operating mechanism – FLD

This can be installed on fixed, plug-in or withdrawable Tmax T4, T5 and T6 circuit-breakers. In the case of withdrawable circuit-breakers, installed in a switchboard, it allows the IP40 degree of protection to be maintained for the whole isolation run of the circuit-breaker.

It is always fitted with a padlock in the open position (6 mm Ø stem up to three padlocks - not supplied) which prevents closing of the circuit-breaker and of the compartment door, and with compartment door lock. On request, it can be fitted with a key lock in the open position.

It is available in the following versions:

- for fixed or plug-in circuit-breaker
- for withdrawable circuit-breaker.

The front for lever operating mechanism is always an alternative to the motor operator and to the rotary handle and to the display FDU.

The same flange for the compartment door already supplied with the circuit-breaker or the one supplied with the conversion kit for withdrawable version can be used.



1SDC210C82F0001



1SDC210C83F0001

Padlock for operating lever – PLL

This is applied to the T1 - T2 - T3 circuit-breaker cover to prevent the lever closing or opening operation. It allows installation up to a maximum of three padlocks - 7 mm Ø stem (not supplied). It is available in the following versions:

- plug-in locking device only of the closing operation
- locking plate on the closing and opening operation according to the assembly position. The lock on the opening operation does not prevent release of the mechanism following a fault or remote control command
- locking plate just for the closing operation.

It is incompatible with the front accessories: solenoid operator, rotary handle operating mechanism and mechanic interlock.

The padlock is also available for T7 and it is directly mounted on the circuit-breaker cover.

T1-T3

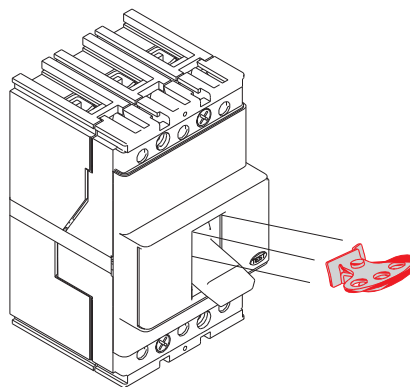

1SDC210C84F0001

T1-T3

Accessories

Operating mechanism and locks



1SDC210C8F0001

Key lock on the circuit-breaker for T1, T2, T3 and T7 – KLC

This allows the mechanical closing operation of the circuit-breaker to be locked and is installed directly on the front in the slot in correspondence with the left pole. This cannot be installed when the front operating mechanism, rotary handle operating mechanism, motor operator, and RC221/RC222 residual current releases are present, or on the three-pole circuit-breakers equipped with service releases (UVR, SOR). The key lock is the Ronis 622 type and is available in two versions:

- standard type, with key only removable with the circuit-breaker locked
- special type, with key removable in both positions.

On T7 the key lock in the open position is mounted directly on the circuit-breaker cover both in the version with different keys and with the same keys. Presetting for Ronis and Profalux key locks are also available.



1SDC210C8F0001

Key lock for rotary handle operating mechanism for T1, T2 and T3 – RHL

This allows the mechanical closing operation of the circuit-breaker to be locked.

The following versions are available:

- lock with different key for each circuit-breaker
- lock with the same key for groups of circuit-breakers.

The circuit-breaker in the open position ensures isolation of the circuit in accordance with the IEC 60947-2 Standard. It is also available in the version which allows the lock both in the open and closed position. The lock in the closed position does not prevent release of the mechanism following a fault or remote control.



1SDC210D24F0001

Key lock for T4, T5, T6 and T7 – KLF-D and KLF-S

This allows mechanical operation of the circuit-breaker to be locked. This lock can be used with the direct or transmitted rotary handle operating mechanism mounted on the base for circuit-breaker or with the front for lever operating mechanism.

The lock of the circuit-breaker in the open position ensures isolation of the circuit in accordance with the IEC 60947-2 Standard. For T4, T5, T6 and T7 in the lever operating mechanism version key locks in the open position are available either with different keys (KLF-D) or with the same keys (KLF-S): in this case, up to four different key numbering codes are available (n. 2005-2006-2007-2008).

Lock in the racked-out position for fixed part (T4, T5 and T6)

For T4, T5 and T6 withdrawable circuit-breakers, key or padlocks locks are available to be applied onto the rail of the fixed part, to prevent racking-in of the plug-in part.

Selection can be made among the following:

- key lock with different keys (KLF-D FP)
- key lock with the same keys for groups of circuit-breakers (KLF-S FP)
- Ronis type key lock (KLF-D Ronis FP)
- padlock, which can take up to three padlocks with 6 mm stem Ø, not supplied (PLL FP).



1SDC2100294F0001

Lock in racked-in – isolated – racked-out position for fixed part of T7

This device allows the moving part of a withdrawable version T7 circuit-breaker to be locked in the racked-in, isolated-test or racked-out position in the relative fixed part. Thanks to mounting an additional accessory, the lock can be limited just to the racked-out position. The fixed part can be equipped with 1 or 2 of these key locks.



1SDC210025F0001

Mechanical lock of compartment door

Available on T7 both for the lever operating mechanism and for the motorizable version. It does not allow the compartment door to be opened with the circuit-breaker closed (and circuit-breaker racked-in for circuit-breakers in the withdrawable version) and locks the circuit-breaker closing with the compartment door open.

Two versions are available: a door lock made by means of cables and a second type fixed directly on the side of the circuit-breaker or of the relative fixed part. The cable door lock must also be fitted with the interlock cable kit and the interlocking plate corresponding to the combined circuit-breaker.



1SDC210037F0001

Sealable thermal adjustment lock

This is applied to the circuit-breaker cover near the thermal element regulator of the TMD thermomagnetic trip unit for T1, T2 and T3 and prevents it being tampered with.

Overview of the available locks

	T1	T2	T3	T4	T5	T6	T7
FDL Front for lever operating mechanism				■	■	■	
PLL_ Padlock for operating lever	■	■	■				■
KLC_ Key lock on the circuit-breaker	■	■	■				■
RHL Keylock for rotary handle operating mechanism	■	■	■				
KLF-D and KLF-S Key lock for front for lever and rotary handle				■	■	■	
MOL-D and MOL-S_ Key lock in open position for MOE and MOE_E				■	■	■	
MOL-M_ Key lock against manual operation for MOE and MOE_E				■	■	■	
KLF-FP and PLL FP_ Locks in open position for fixed part				■	■	■	■
Mechanical lock on compartment door							■
Sealable lock of thermal adjustment	■	■	■				

Accessories

Operating mechanism and locks



1SDC210C8BF0001

T1-T2-T3



1SDC210C8BF0001

T3-T4-T5-T6

Mechanical interlock

T1-T2-T3

The mechanical MIF interlock can be applied on the front of two T1, T2 or T3 circuit-breakers mounted side by side, in either the three-pole or four-pole fixed version and prevents simultaneous closing of the two circuit-breakers. Fixing is carried out directly on the back plate of the switchboard. The front interlocking plate allows installation of a padlock in order to fix the position (possibility of locking in the O-O position as well). It is also possible to interlock three circuit-breakers side by side, using the proper plate, thereby making the following interlock combinations: IOO-OIOOOI-OOO. It is incompatible with the front accessories (solenoid operator, rotary handle operating mechanism) and with the residual current releases.

T3

For T3, in the three-pole or four-pole fixed or plug-in version, the MIR mechanical interlock is available. This rear interlock, available in the horizontal (MIR-H) and vertical (MIR-V) version, is compatible with all the front accessories and with the residual current release (only MIR-H). The following interlocking combinations can be made: IO-OI-OO.

T4-T5-T6

The mechanical interlock for T4, T5 and T6 allows installation of two circuit-breakers on a single support and, by means of special lever mechanisms, makes them mechanically interdependent. For Tmax T4 and T5 this is a rear interlock consisting of a vertical or horizontal frame group (MIR-HR or MIR-VR) and of a pair of metal plates for fixing the circuit-breakers (MIR-P). The frame group is made up of metal frame and of the lever mechanism interlock. The metal plates are of different type according to the sizes of circuit-breakers to be interlocked. For Tmax T6 this is a rear interlock consisting of a vertical or horizontal support. The following interlocking combinations can be made: IO-OI-OO.

Interlock

Type			
A	T4 (F-P-W)	+	T4 (F-P-W)
B	T4 (F-P-W)	+	T5 400 (F-P-W) o T5 630 (F)
C	T4 (F-P-W)	+	T5 630 (P-W)
D	T5 400 (F-P-W) o T5 630 (F)	+	T5 400 (F-P-W) o T5 630 (F)
E	T5 400 (F-P-W) o T5 630 (F)	+	T5 630 (P-W)
F	T5 630 (P-W)	+	T5 630 (P-W)

There are no limitations on the versions to be interlocked, therefore, for example, a fixed circuit-breaker can be interlocked with a withdrawable version switch-disconnector.

Since this is a rear interlock, all the front accessories which are compatible with the circuit-breakers installed can be used.

In the vertical interlock the bottom terminals of the upper circuit-breaker and the top terminals of the lower circuit-breaker must be of rear type.

To be able to receive the circuit-breakers mounted directly on the interlocking plate, code "1SDA050093R1" must be specified as the accessory of the second circuit-breaker (or fixed part) you want to interlock.

The following interlocking combinations can be made: IO-OI-OO.

T7

This mechanism makes the mechanical interlock between two T7 circuit-breakers by means of flexible cables, which are connected on a plate mounted on the side of the circuit-breaker preventing simultaneous closing of the two circuit-breakers. The plates to be mounted on the circuit-breaker differ according to whether the circuit-breaker is in the fixed or withdrawable version.

The interlock is available both for the manual operating mechanism version and for the motor operator one.

The following interlocking combinations can be made: IO-OI-OO.



1SDC210D26F0001



1SDC210D27F0001

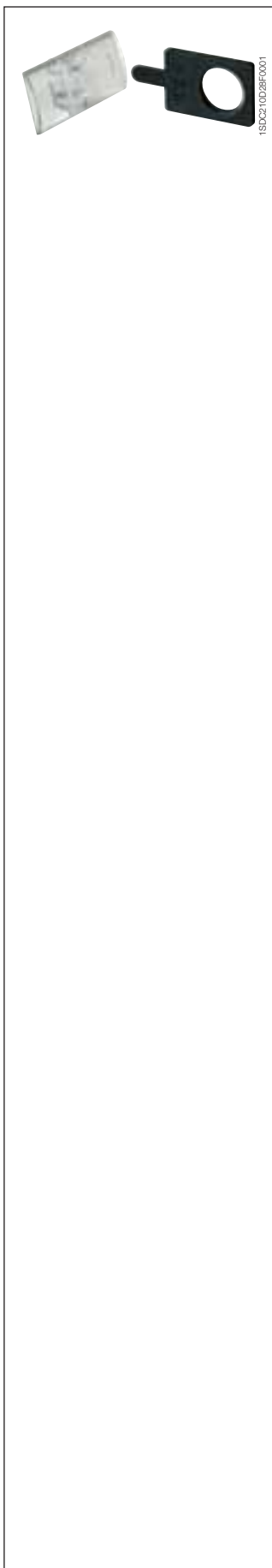

Transparent pushbutton protection – TCP

A transparent protection for the circuit-breaker opening and closing pushbuttons is available in two different versions on T7 with stored energy operating mechanism: one which protects both the push-buttons and the other which alternatively protects either the opening or the closing pushbutton. There is the possibility of putting a padlock, which adds the lock function to the protection. In the closed position this lock does not prevent release of the mechanism following a fault or a remote command.

IP54 door protection

Available with T7 motorizable, it is made by means of a transparent plastic cover which completely protects the front of the circuit-breaker and allows IP54 degree of protection to be reached. Mounted on hinges, it is provided with a key lock.

Accessories

Residual current releases

All the Tmax series of circuit-breakers, both automatic circuit-breakers and switch-disconnectors, are preset for combined assembly with residual current releases.

In particular, the Tmax T1, T2 and T3 circuit-breakers can be combined with the new version of the SACE RC221 or RC222 series of residual current releases and four-pole T4 and T5 with RC222 or RC223 to be installed below the circuit-breaker.

The T6 and T7 circuit-breakers can be combined with the RCQ residual current switchgear release. Apart from the protection against overloads and short-circuits typical of automatic circuit-breakers, the residual current circuit-breakers derived from them also guarantee protection of people and protection against earth fault currents, thereby ensuring protection against direct contacts, indirect contacts and fire hazards. The residual current releases can also be mounted on the Tmax T1D, T3D, T4D and T5D switch-disconnectors. In that case, the derived apparatus is a “pure” residual current circuit-breaker, i.e. one which only guarantees residual current protection and not the protections typical of circuit-breakers. “Pure” residual current circuit-breakers are only sensitive to the earth fault current and are generally applied as main switch-disconnectors in small distribution switchboards towards end users.

The use of “pure” and “impure” residual current circuit-breakers allows continual monitoring of the state of plant insulation, ensuring efficient protection against fire and explosion hazards and, when the devices have $\Delta n \leq 30$ mA, ensure protection of people against indirect and direct earth contacts to fulfil the compulsory measures foreseen by the accident prevention regulations and prescriptions. The residual current releases are constructed in compliance with the following Standards:

- IEC 60947-2 appendix B
- IEC 61000: for protection against unwarranted release.

They are constructed using electronic technology and act directly on the circuit-breaker by means of a trip coil, supplied with the residual current release, to be housed in the special slot made in the left-hand pole area.

They do not require an auxiliary power supply as they are supplied directly by the network and their operation is guaranteed even with only a single phase plus neutral or only two phases supplied with voltage and in the presence of unidirectional pulsating currents with direct components. All the possible connection combinations are allowed, except for guaranteeing, in the four-pole version, connection of the neutral to the first pole on the left.

The RC221 and RC222 residual current releases can either be supplied from above or from below. The operating conditions of the apparatus can be continually controlled by means of the electronic circuit test pushbutton and the magnetic indicator of residual current trip.

A disconnection device of the power supply during the insulation test is available.

The four-pole circuit-breaker complete with residual current release can be fitted with the electrical accessories normally available for the circuit-breaker. The shunt opening and undervoltage releases are housed in the special slot made in the neutral pole for the four-pole circuit-breakers, whereas they are incompatible with the three-pole circuit-breakers.

The residual current releases are supplied complete with:

- a trip coil to be housed in the area of the third pole, complete with an auxiliary contact signalling residual current release trip
- dedicated flange.

A changeover contact for signalling residual current protection trip is always supplied for Tmax circuit-breakers, combined with the RC221 and RC222 residual current releases. Two changeover contacts for signalling pre-alarm and alarm are also available with the RC222 release.

The opening solenoid for the RC221, RC222 and RC223 residual current releases is available as a spare part.

A circuit-breaker cannot have the residual current release and the rotary handle or the motor operator mounted at the same time (except for MOS in the side-by-side version for T1 and T2).



1SDC210C39F0001



1SDC210C39F0001

T1-T2-T3



1SDC210C32F0001



1SDC210C32F0001

T4-T5

RC221 and RC222 residual current releases for T1, T2 and T3

The RC221 and RC222 residual current releases for T1, T2 and T3 circuit-breakers are available both with three-pole and four-pole circuit-breakers, in the fixed version.

The configuration foresees insertion of the circuit-breaker on the structure of the corresponding residual current release, making access to the adjustments on the left-hand side of the circuit-breaker available, whilst the toroid is in the underneath position.

A distinguishing characteristic is provided by the type of cable connection which is made directly on the circuit-breaker, once the residual current release has been mounted, thereby ensuring simplification and rationalisation of the installation procedure.

With Tmax T2 and T3, only front terminals for copper cables (FC Cu) at the bottom are mounted on the residual current releases.

For this reason, when the residual current release is ordered, the FC Cu terminal semi-kit is always supplied (consult the code section on page 7/36).

On the other hand, for four-pole Tmax T1, it is also possible to mount the rear horizontal flat terminal kit below (HR for RC221/ RC222).

Furthermore, still for four-pole T1, a version of the RC222 residual current release is available in 200 mm modules. This release keeps the same technical characteristics as the normal RC222 for T1, T2 and T3 but, thanks to its reduced height, allows installation in 200 mm modules. Its special shape also allows a reduction in the overall dimensions when two or more units are placed side by side.

The bracket for fixing onto DIN 50022 rail is available on request.

A circuit-breaker cannot have the residual current release and the overlaid solenoid operator or the rotary handle operating mechanism mounted at the same time.

RC222 residual current release for T4 and T5

The RC222 release for T4 and T5 is available in the four-pole version and is mounted below the circuit-breaker.

The release is supplied with standard front terminals, but it can also be combined with all the terminals available for the corresponding circuit-breaker.

The RC222 residual current release, in the fixed version, can easily be converted into plug-in and into withdrawable by adding the special conversion kit and applying a derating of the performances as indicated in the table on the next page.

A circuit-breaker cannot have the residual current release and the motor operator mounted at the same time.

RC223 (B type) residual current release for T3 and T4 250 A

The RC223 residual current trip unit (of type B), which can be combined with Tmax T3 and T4 250 A four-pole fixed, plug-in or withdrawable version circuit-breakers (only plug-in and withdrawable for T4). The RC223, which can only be used in plants with 50/60 Hz frequency, must be supplied from a primary line voltage between 110 V and 500 V. Operation is guaranteed starting from 55 V phase-neutral. It features the same types of reference as the RC222 release (type S and AE), but can also claim conformity with type B operation, which guarantees sensitivity to residual current faults with alternating, alternating pulsating components and with direct current.

The reference Standards are: IEC 60947-1, IEC 60947-2 Annex B, and IEC/TR 60755.

Apart from the signals and adjustments typical of the RC222 residual current release, by means of a three-position 400-700-1000 Hz selector, the RC223 also allows the maximum frequency band of the residual current fault read to be defined. It is therefore possible to adapt the residual current device to the various industrial plant requirements according to the frequency of prospective faults generated on the load side of the release.

Typical installations which may require fault frequency thresholds other than the standard ones (50-60 Hz) are welding plants for the automobile industry (1000 Hz), textile industry (700 Hz), airports and three-phase drives (400 Hz).

A circuit-breaker cannot have the residual current release and the motor operator mounted at the same time.

The RC223 residual current release for T3 has front terminals by default. For connection of the T3 and RC223 assembly use the following:

- on the top terminals of the CB: terminal kit available for size T3;
- on the bottom terminals of the CB: terminal kit available for size T4.

Accessories

Residual current releases

	RC221	RC222		RC223
	T1-T2-T3	T1-T2-T3	T4 and T5 (4p version only)	T3 and T4 (4p version only)
Circuit-breakers size				
Type	"L" shaped	"L" shaped	Placed below	Placed below
Technology	microprocessor-based	microprocessor-based	microprocessor-based	microprocessor-based
Action	with trip coil	with trip coil	with trip coil	with trip coil
Primary service voltage ⁽¹⁾ [V]	85...500	85...500	85...500	110...500
Operating frequency [Hz]	50-60 ⁽³⁾	50-60 ⁽³⁾	50-60 ⁽³⁾	50-60 ⁽³⁾
Fault frequency [Hz]	–	–	–	0...400 - 0...700 - 0...1000
Self-supply	■	■	■	■
Test operation range ⁽¹⁾ [V]	85...500	85...500	85...500	110...500
Rated service current [A]	up to 250 A	up to 250 A	up to 500 A	up to 250 A (225 A for T3)
Rated residual current trip [A]	0.03 - 0.1 - 0.3	0.03 - 0.05 - 0.1 - 0.3	0.03 - 0.05 - 0.1	0.03 - 0.05 - 0.1
	0.5 - 1 - 3	0.5 - 1 - 3 - 5 - 10	0.3 - 0.5 - 1 - 3 - 5 - 10	0.3 - 0.5 - 1
Time limit for non-trip [s]	instantaneous	instantaneous - 0.1 - 0.2 - 0.3 - 0.5 - 1 - 2 - 3	instantaneous - 0.1 - 0.2 - 0.3 - 0.5 - 1 - 2 - 3	instantaneous - 0 - 0.1 - 0.2 - 0.3 - 0.5 - 1 - 2 - 3
Tolerance over trip times		± 20%	± 20%	± 20%
Power consumption ⁽²⁾	< 8 W at 400 V AC	< 10 W at 400 V AC	< 10 W at 400 V AC	< 10 W at 400 V AC
Local trip signalling	■	■	■	■
Trip coil with changeover contact for trip signalling	■	■	■	■
Input for remote opening		■	■	■
NO contact for pre-alarm signalling		■	■	■
NO contact for alarm signalling		■	■	■
Indication of pre-alarm from 25% I _{Δn} (tolerance ±3%)	■	■	■	■
Indication of alarm timing at 75% I _{Δn} (tolerance ±3%)	■	■	■	■
"A" type for pulsating alternating current, AC for alternating current	■	■	■	■
"AE" type for remote release device		■	■	■
Type B for pulsed current and direct current				■
Selective "S" type		■	■	■
Switch for insulation test	■	■	■	■
Power supply from above and below	■	■	■	■
Assembly with three-pole circuit-breakers	■	■	■	■
Assembly with four-pole circuit-breakers	■	■	■	■
Kit for conversion of circuit-breaker with residual current release from fixed to plug-in			■	■

⁽¹⁾ Operation up to 50 V Phase-Neutral (55 V for RC223)

⁽²⁾ The values of power consumption can be inferior at lower supply voltage

⁽³⁾ Tolerance 45...66 Hz

RC222-RC223 T4-T5 Performances

T3
T4 250
T4 320⁽²⁾
T5 400⁽²⁾
T5 630⁽²⁾

Maximum withstand current

Fixed	Plug-in/Withdrawable
250 A ⁽¹⁾	–
250 A	250 A
320 A	280 A
400 A	400 A
500 A	–

⁽¹⁾ 225 A with RC223

⁽²⁾ Available only with RC222



1SDC21002HF0001

Homopolar toroid for residual current protection

The electronic PR332/P LSIRc and PR332/P LSIG (with PR330/V and rating plug RC) trip units can be used combined with the homopolar toroid for residual current protection, which allows activation of the residual current protection. If used with PR332 LSIG, the G protection is no longer available. This accessory must be mounted on the busbars and is available in a single size up to 1600 A. This accessory is alternative to the homopolar sensor. The PR332/P LSIRc electronic trip unit can be used combined with this accessory, which allow the activation of the residual current protection.



1SDC210039F0001



1SDC210039F0001

Homopolar sensor for the main power supply earthing conductor (star centre of the transformer)

SACE PR332/P electronic trip units can be used in combination with an external sensor located on the conductor, which connects the star centre of the MV/LV transformer (homopolar transformer) to earth. In this case, the earth protection is defined as Source Ground Return. Through two different combinations of connection of its terminals, the In of the same toroid can be set at 100 A, 250 A, 400 A, 800 A.

This is alternative to the homopolar toroid for residual current protection.

SACE RCQ switchboard residual current relay

The Tmax circuit-breakers can also be combined with the SACE RCQ switchboard relay with separate toroid (to be installed externally on the line conductors) and these fulfil requirements with thresholds up to 30 A trips and times up to 5 s or when the installation conditions are particularly restrictive, such as with circuit-breakers already installed, or limited space in the circuit-breaker compartment.

Thanks to the wide range of settings, the SACE RCQ switchboard relay is suitable for applications where a system of residual current protection coordinated with the various distribution levels, from the main switchboard to the end user, is required. It is particularly recommended when low sensitivity residual current protection is required, such as in partial (current) or total (chronometric) selective chains, and for high sensitivity applications (physiological sensitivity) to provide protection of people against direct contacts.

On a drop in the auxiliary power supply voltage, the opening command can intervene after a minimum time of 100 ms and after the time set plus 100 ms.

The SACE RCQ relay is a type A residual current relay and detects residual currents both of the alternating and pulsating type with continuous components.

The SACE RCQ relay is of the type with indirect action and acts on the circuit-breaker release mechanism by means of the shunt opening release (or of the undervoltage release) of the circuit-breaker itself (to be ordered by the user), to be housed in the special slot made on the left-hand pole of the circuit-breaker.

Residual current relay		SACE RCQ	
Power supply voltage	AC [V] DC [V]	80 ... 500	48 ... 125
Operating frequency	[Hz]	45 ÷ 66 Hz	
Power consumption on in rush		100 [VA] / 100 [W]	
Power consumption in service		6 [VA] / 6 [W]	
Trip threshold adjustment $I_{\Delta n}$			
1st range of adjustments	[A]	0.03-0.05-0.1-0.3-0.5	
2nd range of adjustments	[A]	1-3-5-10-30	
Trip time adjustment	[s]	instantaneous 0.1-0.2-0.3-0.5-0.7-1-2-3-5	
Pre-alarm threshold adjustment	[%] x $I_{\Delta n}$	25 ... 75% x $I_{\Delta n}$	
Range of use of closed transformers			
Toroidal transformer Ø 60 [mm]	[A]	0.03 ... 30	
Toroidal transformer Ø 110 [mm]	[A]	0.03 ... 30	
Toroidal transformer Ø 185 [mm]	[A]	0.1 ... 30	
Range of use of transformers which can be opened			
Toroidal transformer Ø 110 [mm]	[A]	0.3 ... 30	
Toroidal transformer Ø 180 [mm]	[A]	0.3 ... 30	
Toroidal transformer Ø 230 [mm]	[A]	1 ... 30	
Signalling for alarm pre-threshold		Yellow flashing LED 1 N.O., change-over contact 6 A - 250 V AC 50/60 Hz	
Residual current relay trip signalling		Yellow magnetic flag change-over contacts (N.O. N.C.; N.O.) 6 A - 250 V AC 50/60 Hz	
Remote opening control		N.O. contact - Trip time 15 ms	
Connection to the toroidal transformer		By means of 4 twisted conductors. Maximum length: 5 m	
Dimensions W x H x D	[mm]	96 x 96 x 131.5	
Drilling for assembly on door	[mm]	92 x 92	
Degree of protection on the front		IP41	
Degree of protection on the rear		IP30	

Accessories

Accessories for electronic trip units



1SDC210038F0001

Front display unit – FDU

The front display is a display unit of the setting currents, alarms and parameters of the PR222DS/P, PR222DS/PD, PR223DS and PR223EF electronic trip units of T4, T5 and T6. The display unit can operate correctly with self-supply with $I \geq 0.35 \times I_n$ on at least one phase.

If the display is used in combination with the PR222DS/PD, PR223DS or PR223EF trip units, and therefore with an auxiliary power supply, it is also possible to detect the protection, which has caused the release trip and the fault current.

Connection of the display to the PR223DS and PR223EF trip units must, compulsorily, pass through the AUX-E auxiliary contacts in electronic version, whereas with the PR222DS/P trip unit it can be made directly.

It is not compatible with the front accessories: rotary handle operating mechanism, motor operator and front for lever operating mechanism.

When combined with PR223DS trip unit with VM210 device, the FDU is able to display a wide range of measurements, as shown in the table.

Measurement	With N	Without N
Effective current values	I_1, I_2, I_3, I_n	I_1, I_2, I_3
Effective voltage values	$V_1, V_2, V_3, V_{12}, V_{23}, V_{31}$	V_{12}, V_{23}, V_{31}
Apparent powers	S_{tot}, S_1, S_2, S_3	S_{tot}
Active powers	P_{tot}, P_1, P_2, P_3	P_{tot}
Reactive powers	Q_{tot}, Q_1, Q_2, Q_3	Q_{tot}
Power factors	cos	cos
Active energy	■	■
Reactive energy	■	■
Apparent energy	■	■
Frequency	■	■
Peak factors	■	■
Circuit-breaker state		
Protection function parameters	■	■
Trip warnings and alarms (only with Vaux)	■	■
Phase 1, 2, 3 and N trip current	■	■
Protection tripped (L, S, EF ⁽¹⁾ , I, G)	■	■
Current levels and trip times (L, S, EF ⁽¹⁾ , I, G)	■	■

⁽¹⁾ only PR223EF

VM210

The VM210 accessory, combined with the PR223DS and PR223EF trip units for T4, T5 and T6, is able to provide the various measurements of the electrical values of the plant.

The VM210 can provide the measurements relative to a maximum of 5 PR223DS or PR223EF trip units. The maximum connection distance between the module and the trip unit is 15 meters. For distances longer than 1 meters, a shielded multi-core cable must be used.

VM210 Conditions of use	Values
Power supply	24 V DC $\pm 20\%$
Ripple	$\pm 5\%$
Operating Temp.	-25 °C...+70 °C
Relative humidity	5%...98%
Certifications	
Product	IEC 60068
Electromagnetic compatibility	IEC 61000



1SDC210038F0001

HMI030 interface on the front of switchgear

This accessory, which can be used with all the protection trip units fitted with dialogue, is designed for installation on the front of the switchgear. It consists of a graphic display where all the trip unit measurements and alarms/events are displayed. The user can navigate in a simple and intuitive way among the measurements by using the navigation pushbuttons. The device can replace the traditional multimeters without the need for current/voltage transformers. The HMI030 is connected directly to the protection trip unit by means of a serial line and requires a 24 V DC power supply.

Optional modules

The PR332/P trip unit for T7 can be enriched with additional internal modules, thereby increasing the capacity of the trip units and making these units highly versatile.

PR330/V voltage measuring module

The PR330/V module measures and processes the phase and neutral voltages, transferring these data to the protection trip unit so that a series of protection and measurement functions can be implemented.

The module has two different positions, which can be selected using the special selector: the “Connected” position where the protection and measurement functions are active, and the “Insulating Test” position where the module is disconnected from the busbars.

The PR330/V module is available in two different configurations:

1. Module with internal voltage sockets, with connection directly to the top terminals of the circuit-breaker, for use in networks with line voltages up to 690 V.
2. Module with external voltage sockets, with connection through the circuit-breaker terminal box and voltage transformers, for connections to the bottom terminals or for use in networks with line voltages higher than 690 V.

The new module will only be available mounted inside the circuit-breaker.

The PR332/P LSIRc, PR333/P LSI and PR333/P LSIg protection trip units are supplied as standard with the internal voltage sockets; the external voltage sockets can be requested by specifying the relative extracode together with the circuit-breaker code.

PR330/D-M communication module (Modbus RTU)

The PR330/D-M communication module is the solution for connecting Tmax to a Modbus network for remote supervision and control of the circuit-breaker.

It is suitable for the PR332/P trip unit for T7. As for the PR330/V, this module can be added to the protection trip unit and its presence is recognised automatically.

The electronic trip unit is supplied with three LEDs on the front:

- “Power” power supply LED, which indicates the presence of auxiliary power supply to the PR333/ D-M module
- “Tx” data transmission LED
- “Rx” data reception LED.

PR330/R – Actuator module

The PR330/R actuator module is fitted in the right slot of T7 and it is used for opening (for T7 with lever operating mechanism it is allowed only the opening operation), and closing the circuit-breaker by means of the shunt opening and closing releases by remote control. It is suitable for the PR332/P and must be compulsory ordered with the PR330/D-M communication module.

BT030 wireless communication unit

BT030 is a device to be connected to the Test connector of PR222DS, PR223DS, PR223EF, PR232/P, PR331/P and PR332/P. It allows Bluetooth communication between the protection trip unit and a hand-held or laptop PC with a Bluetooth port. BT030 can also be used with Emax circuit-breakers fitted with PR121/P, PR122/P and PR123/P.

This device is dedicated to use with the SD-Pocket und SD-TestBus2 application.

BT030 can provide the power supply needed for self-supply and for the protection release by means of a rechargeable Li-ion battery.

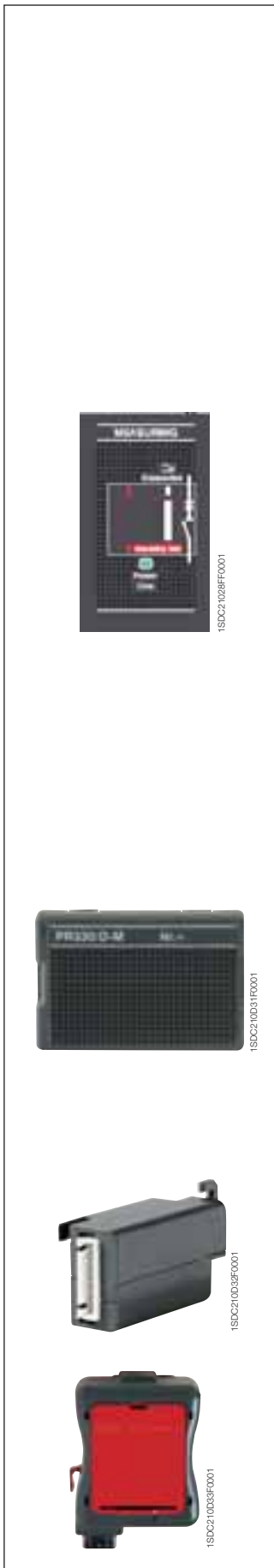

Accessories

Accessories for electronic trip units



1SDC210034F0001

PR030/B power supply unit

With this accessory, which is always supplied with the PR332/P range of trip units, it is possible to read and configure the parameters of the unit whatever the state of the circuit-breaker is (open-closed, in the isolated for test position or racked-in, with/without auxiliary power supply).

PR030/B is needed for readout of the data relative to trips if the trip occurred more than 48 hours previously and the trip unit was no longer supplied.

An electronic circuit inside it allows power supply to the unit for about 3 hours continuously to carry out just the data reading and configuration operations.

The life of the battery decreases if the SACE PR030/B is also used to carry out the Trip test and the Auto test.

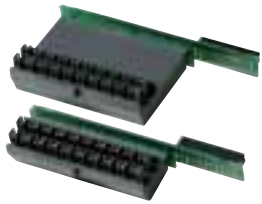

1SDC210036F0001

Trip unit adapter

In order to allow all the connections between the electronic trip unit type PR33x and the terminal board on the circuit-breaker, the circuit-breaker it self must be fitted with a trip unit adapter.

Two different trip unit adapters are available: one is suitable with T7 level operating mechanism, the other with T7 motorizable.



1SDC210038F0001

Rating plug

Available on the electronic trip units which can be mounted on T7, it must be applied on the front of the trip unit itself and provides information about the current sensor settings. It is therefore no longer necessary to change the circuit-breaker current sensors, but is sufficient just to replace the rating plug to obtain modification of the rated current of the circuit-breaker.

Type of circuit-breaker	Rated current I _n	I _n (A)					
		400	630	800	1000	1250	1600
T7	800	■	■	■			
	1000	■	■	■	■		
	1250	■	■	■	■	■	
	1600	■	■	■	■	■	■



1SDC210039F0001

EP010 - FBP

It is the “E-plug” interface which can connect T4, T5 and T6, equipped with the PR222DS/PD electronic trip unit, to the field bus plug system, allowing user to choose among several field bus system (ASI, Device Net, Profibus). This must be connected to the PR222DS/PD trip unit by means of the specific X3 connector. It can be used with T7 with PR332/P electronic trip unit equipped with PR330/D-M communication module.

When using EP010 for profibus, the PDP22 Fieldbus Plug must be used. The PDP21 Fieldbus Plug cannot be used with EP010.



1SDC210001F0001

SACE PR212/CI contactor control unit

The SACE PR212/CI accessory unit can be associated with PR222MP for Tmax and PR212MP for the SACE Isomax S family.

When the special dip switch on the front of the PR222/MP is positioned on “Normal mode” working mode, it is possible to control contactor opening in the case of a fault due to overload L, locked rotor R or missing/unbalance of phase U.

The SACE PR212/CI unit can be installed either on a DIN rail or on the rear of the door.



1SDC210037F0001

SACE PR021/K signalling unit

The SACE PR021/K signalling unit can convert the digital signals supplied by the PR222DS/PD (LSI or LSIG), PR222MP, PR223DS, PR223EF, PR331 and PR332 trip unit into electrical signals, with normally open electrical contacts.

The unit is connected to the protection trip unit by means of the Modbus RTU standard serial changeover line, on which all the information about the activation status of the protection functions flows. The corresponding electrical contacts are closed based on these information.

In particular, the following signals are available:

- the alarm signal remains active throughout the overload, until the trip unit is tripped
- the trip signals of the protections remain active during the timing phase, and even after the trip unit is tripped.

A reset pushbutton allows the state of all the signals to be reset.

The unit also has ten LEDs to visually signal the following information:

- “PW/WD”: auxiliary power supply present and W.D.
- “TX/RX”: flashing synchronised with dialogue with the serial Bus and several warning indications
- eight LEDs associated with the internal contacts.

The table indicates the characteristics of the signalling relays available in the SACE PR021/K unit.

Power contacts electrical characteristics

Maximum changeover power (resistive load)	100W / 1250 VA (resistive load)
Maximum changeover voltage	130 V DC / 250 V AC
Maximum changeover current	5 A
Breaking capacity (resistive load) @ 30 V DC	3.3 A
Breaking capacity (resistive load) @ 250 V AC	5 A
Contact/coil insulation	2000 V rms (1 min @ 50 Hz)

Note: the PR021/K unit is an alternative to any supervision and control systems.

Available signals

K51

1
2
3
4
5
6
7
8

PR222MP

Protection L alarm
Protection R alarm
Protection I alarm
Protection U alarm
Welded contactor alarm contacts ⁽¹⁾
Bus K.O.
PTC alarm (temperature sensor on motor)
Generic input 0/1 ⁽¹⁾
Release trip
Protection L pre-alarm
Back-up protection alarm ⁽¹⁾

⁽¹⁾ alternatively by means of dip-switch.

K51

1
2
3
4
5
6-7
8

PR222DS-PR223DS-PR223EF

Protection L alarm
Protection S alarm
Protection I alarm
Protection G alarm
Bus K.O.
Release trip
Protection L pre-alarm

Accessories

Accessories for electronic trip units

Current sensor for external neutral

This is applied to the external neutral conductor and allows protection G against earth faults to be carried out with external neutral three-pole circuit-breakers.

The current sensor must be connected to the trip unit by means of the specific connectors X4 for T4, T5 and T6 or with a direct connection in the terminal board for T7. The combination is not possible with electronic trip unit PR221, PR231 and PR232.

T4 [A]	T5 [A]	T6 [A]	T7 [A]
100	320	630	400...1600
160	400	800	
250	630	1000	
320			

Connectors

Connectors X3 and X4 allow connection of the electronic trip units with external plant units or components. In fact, they are used to make the L alarm signal available outside, connection of the external neutral, connection to the PR021/K signalling unit, to the PR212/CI contactor control unit or to the temperature sensor of the PTC motor and allows two-way communication from the circuit-breaker fitted with dialogue towards the outside and vice versa.

Both the connectors are available both for fixed version circuit-breakers and for plug-in or withdrawable version circuit-breakers.

Connector	Function	Trip unit
X3	PR021/K	PR222DS/PD, PR223DS and PR223EF
	L alarm signal	PR222DS/P, PR222DS/PD, PR223DS and PR223EF
	Auxiliary supply	PR222DS/PD, PR223DS, PR223EF and PR222MP
	Connection to load side circuit-breaker	PR223EF
	EP 010	PR222DS/PD, PR223DS and PR223EF
X4	External neutral	PR222DS/P, PR222DS/PD, PR223DS and PR223EF
	VM210	PR223DS and PR223EF
	PR212/CI	PR222MP
	PTC generic contact 0/1	PR222MP
	Connection to supply side circuit-breaker	PR223EF

SW210 Bus Switch

The SW210 Switch module was created to be used in combination with the EFDP zone selectivity system for plant applications where the possibility of carrying out zone selectivity with open ring (railway tunnels, underground railways, etc.) and distribution plants where a high level of service continuity is required. Following a fault with ring distribution, a part of the plant can be isolated and the electric network re-supplied from another direction.

The SW210 module allows the up-link and down-link signals to be inverted for a pair of circuit-breakers fitted with PR223EF electronic release, re-ordering the hierarchy between the circuit-breakers when the flow of power is inverted. The state of the contacts after the changeover is indicated by a yellow LED coming on.

The module is controlled by a status signal of 24 V DC \pm 20% and is available in a housing to be mounted on a DIN rail (one module).

Accessories for trip units

Circuit-breakers	T2-T4-T5-T6		T4-T5-T6				T7			
	PR221	PR222DS/P	PR222DS/PD	PR222MP	PR223DS	PR223EF	PR231/P	PR232/P	PR331/P	PR332/P
Trip units										
Accessories										
TT1 - Test unit	■	■	■	■	■	■	■	■		
PR010/T - Test unit		■	■	■	■	■		■	■	■
PR021/K ⁽¹⁾ - Signalling unit			■	■	■	■			■	■
FDU ⁽²⁾ - Front display unit		■	■		■	■				
HMI030 ⁽¹⁾ - Interface on the front of switchgear			■		■	■			■	■
VM210 - Voltage measuring unit					■	■				
X3 - Connectors		■	■ ⁽³⁾	■	■ ⁽³⁾	■ ⁽³⁾				
X4 - Connectors		■	■	■	■ ⁽³⁾	■ ⁽³⁾				
X13 - Connectors SHORT/LONG		■	■	■	■	■			■	■
BT030 - Wireless communication unit		■	■		■	■		■	■	■
MOE-E (AUX-E included) ⁽²⁾ - Motor operator			■		■	■				
AUX-E - Auxiliary contacts			■		■	■				
EP010 ⁽¹⁾ - Field Bus plug			■		■	■				■
CT - Current transformers		■	■	■	■	■				
PR212/CI - Contactor control unit				■						
Extracode for interchangeability							■			
Rating plugs							■			
PR030/B - Power supply unit								■	■	■
PR330/D-M - Communication module									■	■
PR330/V - Voltage measuring module										■
PR330/R - Actuator module										■
CT Sensor - Current sensors									■	■
SW210 - Bus switch						■				

⁽¹⁾ Accessories not compatible

⁽²⁾ Accessories not compatible

⁽³⁾ Compulsory

Accessories

Test and configuration accessories



1SDC210009F001

SACE PR010/T test and configuration unit

The SACE PR010/T unit is an instrument capable of performing the Test, programming and parameter reading functions for the protection units equipping SACE Isomax S and Tmax moulded-case circuit-breakers and SACE Emax\air circuit-breakers.

In particular, for Tmax T4, T5, T6 and T7 circuit-breakers fitted with the different versions of trip units, the test programming and parameter reading functions are available.

All the functions mentioned can be carried out ON BOARD by connecting the SACE PR010/T unit to the front multi-pin connector on the protection units. Special interfacing cables supplied as standard with the unit guarantee the connection.

The human-machine interface is ensured by using a membrane keypad and a multi-line alphanumeric display.

There are also two LEDs on the unit which indicate, respectively:

- POWER-ON and STAND BY state
- state of the battery charge.

Two different types of test are provided: manual and automatic.

By means of connection to a computer (with the software supplied by ABB SACE), it is possible to upgrade the software of the SACE PR010/T unit to allow upgrading of the test unit as new products are developed.

The results of greatest interest regarding the test can, moreover, be stored in the unit itself and sent to the PC on specific request for "issue of report".

In automatic and manual mode the SACE PR010/T unit can test:

- protection functions L, S, I, G
- protection functions L, R, I, U (for PR222MP)
- monitoring correct operation of the microprocessor.

The SACE PR010/T unit is portable, operating with rechargeable batteries and/or with an external power supply.

In the standard supply, the unit includes the following:

- SACE PR010/T test unit complete with rechargeable batteries
- SACE TT1 test unit
- 100...240 V AC/12 V DC external power supply
- connection cables between the unit and the multi-pin connector on the range of trip units which equip the Tmax, SACE Isomax S and SACE Emax series
- connection cable between the unit and the PC (RS232 serial)
- power supply cable
- instruction manual and diskette with application SW
- plastic container.



1SDC210004R001

SACE TT1 test unit

This allows tripping of all the electronic trip units which equip the Tmax family of circuit-breakers in the various versions (except for PR33x) to be checked and the trip test of the trip coil (CTC). The device, supplied with power by means of a replaceable 12 V battery, is provided with a two-pole polarised connector housed at the back of the box which allows connection of the device to the test input bushings located on the front of the electronic trip unit.

The compact dimensions of the accessory make it practically pocket size.

Accessories

Automatic transfer switch - ATS010

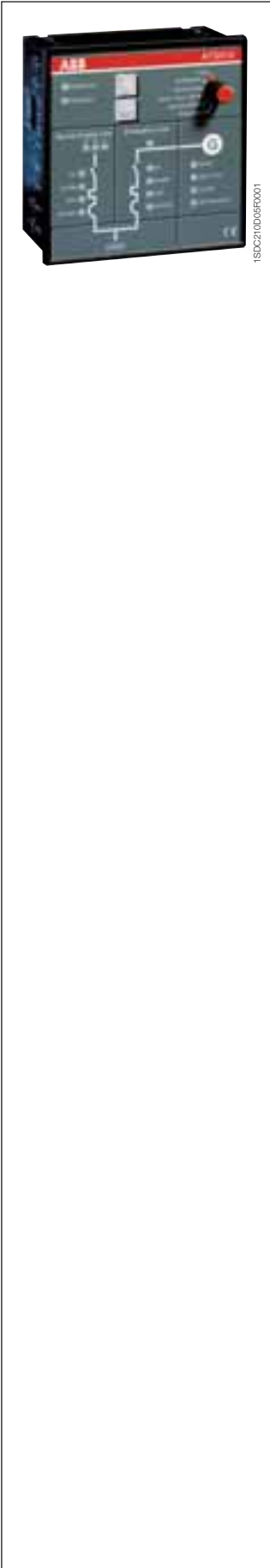

Automatic transfer switch – ATS010

The switching unit ATS010 (Automatic Transfer Switch) is the new network-group switching device offered by ABB SACE. It is based on microprocessor technology in compliance with the leading electromagnetic compatibility and environmental standards (EN 50178, EN 50081-2, EN 50082-2, IEC 60068-2-1, IEC 60068-2-2, and IEC 60068-2-3).

The device is able to manage the entire switching procedure between the normal line and emergency line circuit breakers automatically, allowing great flexibility of settings. In case of an error in the normal line voltage, in accordance with the delays set, the normal line circuit breaker is opened, the generator started and the emergency line circuit breaker closed. Similarly, when the normal line returns to range, the reverse switching procedure is automatically controlled.

It is especially suited for use in all emergency power supply systems requiring a solution that is ready to install, easy to use and reliable.

Some of the main applications include: power supply for UPS (Uninterrupted Power Supply) units, operating rooms and primary hospital services, emergency power supply for civilian buildings, airports, hotels, data banks and telecommunications systems, power supply of industrial lines for continuous processes.

The switching system consists of the ATS010 unit connected to two motor-driven and mechanically interlocked circuit breakers.

The Tmax T4, T5, T6 and T7 circuit-breakers and the switch-disconnectors of the respective sizes can be used (for T3, please ask ABB SACE).

The built-in mains sensor of the SACE ATS010 device makes it possible to detect errors in the mains voltage. The three inputs may be directly connected to the three phases of the normal power supply line for networks with rated voltage up to 500 V AC. Networks with a higher voltage require the insertion of voltage transformers (TV), setting a rated voltage for the device that matches their secondary voltage (typically 100 V).

Two change-over contacts for each circuit breaker connect directly to the motor operator. The circuit breaker connection is completed by wiring the status contacts: Open/Closed, Relay tripped, Racked-in (for draw out/plug-in circuit-breakers).

That is why on every circuit breaker connected to the ATS010 unit, the following are included in addition to the mechanical interlock accessories:

- motor operator from 24 V to 110 V DC or up to 250 V AC
- key lock only against manual operation for motor operator
- open/closed contact and contact for tripped
- racked-in contact (in the case of withdrawable)

The ATS010 device is designed to ensure extremely high reliability for the system it controls. It contains various safety systems intrinsically related to software and hardware operation.

For software safety, a special logic prevents unwarranted operations, while a constantly operative watchdog system points out any microprocessor malfunctions via a LED on the front of the device.

Hardware safety allows integration of an electrical interlock via power relay, so that there is no need to use an external electrical interlock system. The manual selector on the front of the device can also control the entire switching procedure, even in the event of a microprocessor fault, by working electromechanically on the control relays.

General specifications

Rated supply voltage (galvanically insulated from earth)	24 V DC ± 20% 48 V DC ± 10% (maximum ripple ± 5%)
Maximum absorbed power	5 W @ 24 V DC 10 W @ 48 V DC
Rated power (mains present and circuit breakers not controlled)	1.8 W @ 24 V DC 4.5 W @ 48 V DC
Operating temperature	-25 °C...+70 °C
Maximum humidity	90% without condensation
Storage temperature	-25 °C...+80 °C
Protection rating	IP54 (front panel)
Dimensions [mm]	144 x 144 x 85
Weight [kg]	0.8

Accessories

Automatic transfer switch - ATS010

Setting range for thresholds and times

Minimum voltage	Un Min	-5%...-30% Un
Maximum voltage	Un Max	+5%...+30% Un
Fixed frequency thresholds		10%...+10% fn
t_1 : opening delay of the normal line circuit breaker due to network error	(CB-N)	0...32s
t_2 : generator start-up delay due to network error		0...32s
t_3 : stopping delay of the generator		0...254s
t_4 : switching delay due to network stop		0...254s
t_5 : closing delay of the emergency line circuit breaker after detecting the generator voltage	(CB-E)	0...32s

Operating sequence

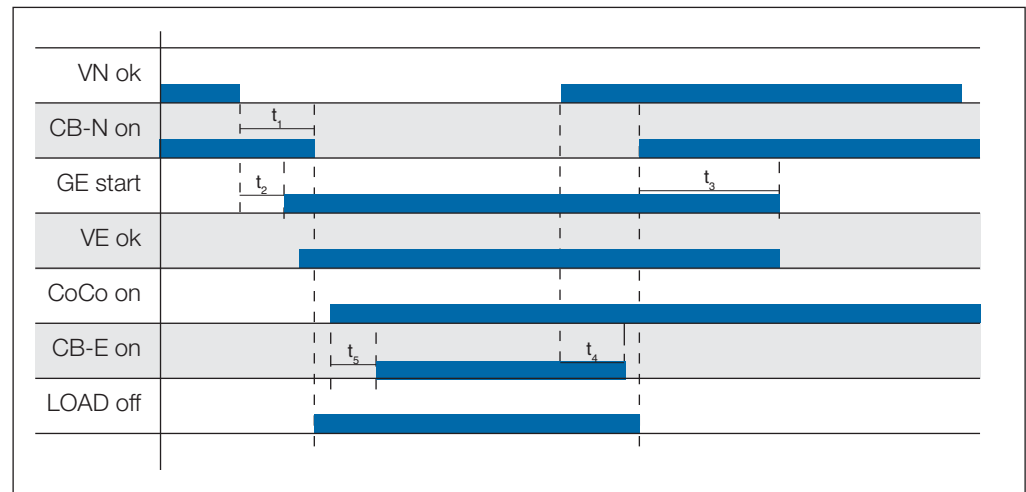

Caption

VN	Mains voltage
CB-N	Normal line circuit breaker closed
GE	Generator
VE	Emergency line voltage
CoCo	Enable switching to emergency line
CB-E	Emergency line circuit breaker closed
LOAD	Disconnection of lower priority connected loads

Side panel settings

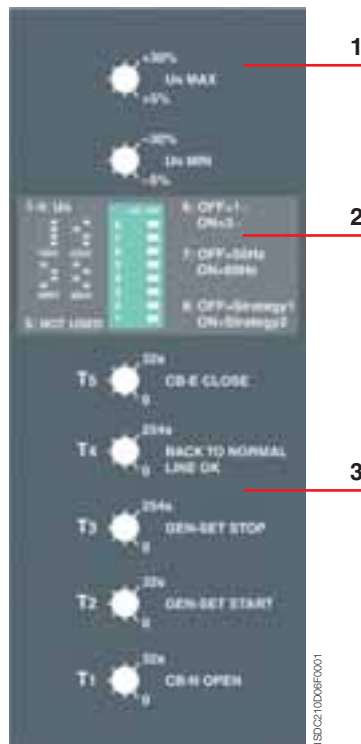

Caption

- 1 Selectors to set the under- and over-voltage thresholds
- 2 Dip-switches to set:
 - rated voltage
 - normal single-phase or three-phase line
 - mains frequency
 - switching strategy
- 3 Switching delay time settings for T1...T5

3

Front panel



Caption

- 1 Status of the ATS010 unit and logic
- 2 Operating mode selector
- 3 Normal line check
- 4 Normal line circuit breaker status
- 5 Voltage on the emergency line
- 6 Emergency line circuit breaker status
- 7 Generator status

Accessories

Installation accessories and spare parts

Bracket for fixing on DIN rail

This is applied to the fixed circuit breaker and allows installation on standardized DIN EN 50022 rails. It simplifies assembly of the T1 - T2 - T3 circuit breakers in standard switchboards.

The bracket for fixing on DIN rail is also available for Tmax circuit breakers combined with RC221 and RC222 residual current releases or with the solenoid operator of the side-by-side type.



1SDC210098F0001



1SDC210099F0001



1SDC210098F0001

Flange for compartment door

This is always supplied with the Tmax circuit-breakers. All the flanges in the Tmax series are of new design and do not require the use of screws for installation: fixing is greatly simplified by just a simple coupling operation. When a rotary handle operating mechanism or residual current releases is used, a dedicated flange is supplied to be used instead of the one supplied with the circuit-breaker.

For T4, T5, T6 and T7 withdrawable circuit-breakers, the flange supplied with the fixed part must be used instead of the one supplied with the fixed circuit-breaker.

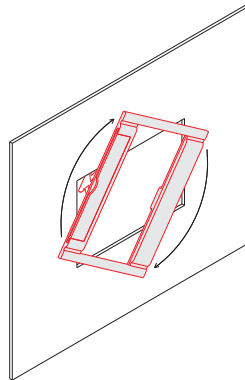

1SDC210016F0001

Spare parts

A wide range of spare parts is available for the Tmax family of circuit-breakers. For further details about the complete range of spare parts available, please ask for the "Spare Parts Catalogue" from the Service Division of ABB SACE.

Accessories

Compatibility of internal accessories

Compatibility

An overview of the assembly compatibility of (internal) accessories with the Tmax Series circuit-breakers can be found in this section.

Possible combination among the internal accessories

The drawing represents the internal slot of the circuit-breakers. A, C and F are housed in the slots on the left of the operating lever, while B, D, E and G in the right one.

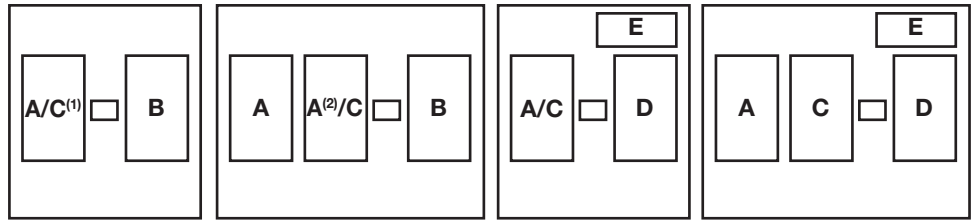

T1, T2 TMD, T3,
T4, T5, T6 3 poles

T1, T2 TMD, T3, T4,
T5, T6 4 poles

T2 PR221DS,
3 poles

T2 PR221DS,
4 poles

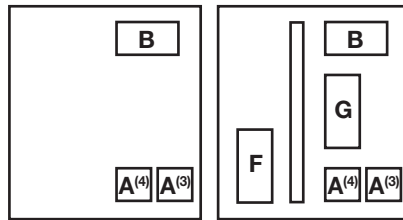

T7 3/4 poles

T7M 3/4 poles

⁽¹⁾ only for T1-T2-T3

⁽²⁾ only SOR-C for T4-T5-T6. Order also the 3-way connector for second SOR-C 1SDA055273R1

⁽³⁾ position for assembly of the SOR

⁽⁴⁾ position for assembly of the UVR

- A = Shunt opening release (SOR) or Undervoltage release (UVR)
- B = Auxiliary contacts
- C = Trip coil of the residual current
- D = Trip coil of the electronic trip unit PR221DS
- E = Auxiliary contacts for T2 with electronic trip unit PR221DS
- F = Spring charging motor
- G = Shunt closing release (SCR)

Accessories

Communication devices and systems

SD-View 2000

SD-View 2000 is a “ready-to-use” system, consisting of software for personal computers, which allows complete supervision of the low voltage electrical installation. Putting the SD-View 2000 system into operation is quick and easy. In fact, the software itself guides the user in recognizing and configuring the protection units. The user only needs knowledge of the installation (such as how many circuit-breakers are installed and how they are connected to each other). No engineering work on the supervision system is required, since all the pages displayed are already configured in the system, ready to be used.

Usage of the software is intuitive and easy to learn for the operator: SD-View 2000 has graphic pages, based on Internet Explorer, which make the system as simple to manage as surfing on the Internet.

System architecture

System architecture is based on the latest developments in personal computer and industrial communication network technology. SD-View 2000 is able to manage up to 8 serial lines, with a maximum of 31 devices each.

System architecture

Maximum number of serial ports RS485	4
Maximum number of devices for each serial port	31
	9600 – 19200 Baud
Protocol	Modbus RTU

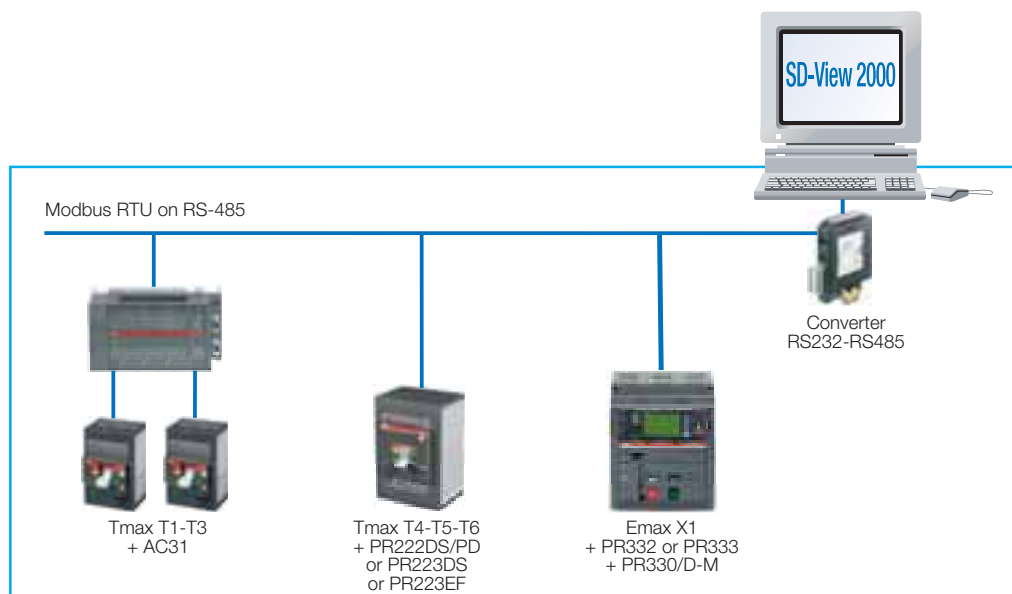

Complete supervision of the installation

SD-View 2000 is the ideal tool available to system managers, in order to have the situation of the installation under control at all times and to be able to supervise all the functions easily and in real time.

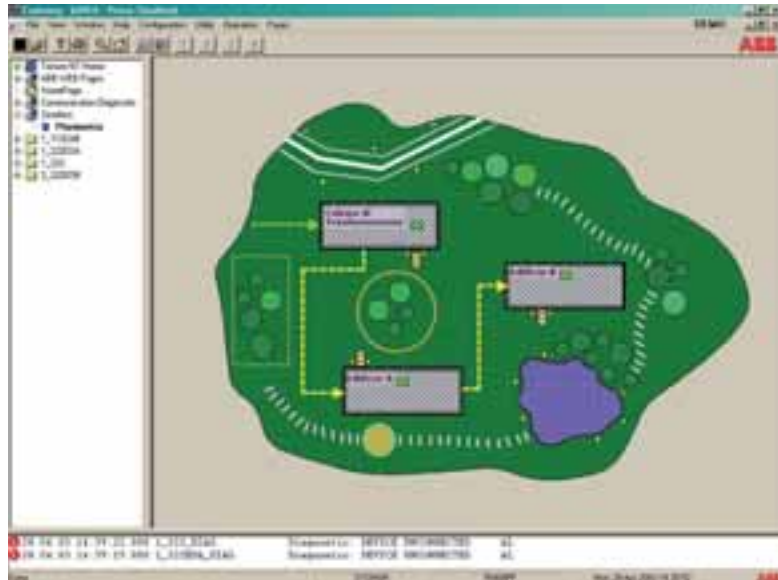

SD-View 2000 allows information from the installation to be received and send commands to the circuit-breakers and the relative trip units.

In particular, it is possible to:

- send opening and closing commands to the circuit-breakers
- read the electrical installation values (current, voltage, power factor, etc.)
- read and modify the trip characteristics of the protection units
- determine the status of the apparatus (open, closed, number of operations, trip for fault, etc.)
- determine the abnormal operating situations (e.g. overload) and, in the case of the releases tripping, the type of fault (short-circuit, earth fault, etc.)
- plot by means of graphs the temporal evolution of the installation, through the history log of currents and voltages (with a time span for 15 days)

Access to the various system functions can be enabled by means of passwords with different levels of authorization. Usage of the system is really simple and the graphic pages relative to each device are particularly intuitive and easy to use.

Devices which can be connected

The circuit-breakers with electronic trip units which can be interfaced with SD-View 2000 are:

- Emax X1 air circuit-breakers and Tmax T7 moulded-case circuit-breakers fitted with PR332/P or PR333/P trip units with Modbus RTU PR330/D-M communication unit
- Emax air circuit-breakers from E1 to E6 fitted with PR122/P or PR123/P trip units with Modbus RTU PR120/D-M communication unit
- Emax air circuit-breakers from E1 to E6 fitted with PR112/PD or PR113/PD Modbus trip units
- Tmax moulded-case circuit-breakers from T4,T5,T6 fitted with PR222DS/PD or PR223DS or PR223EF trip units
- Isomax circuit-breakers from S4 to S7 fitted with PR212/P trip unit with Modbus RTU PR212/D-M communication unit.

Accessories

Communication devices and systems

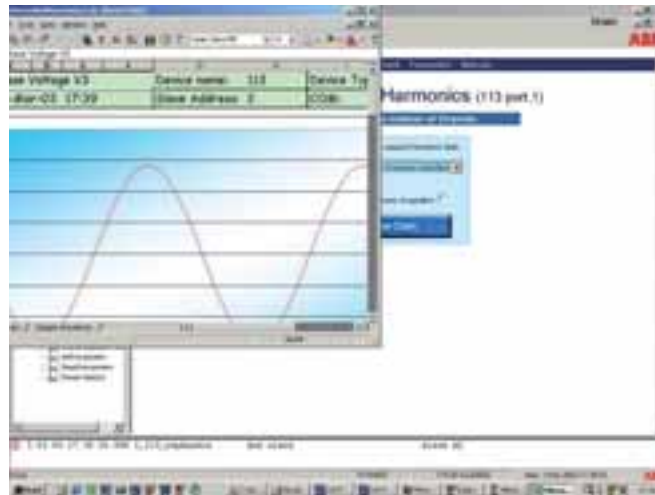

In addition, SD-View 2000 can acquire current, voltage and power measurements in real time from the MTME-485 multimeters with Modbus communication.

Furthermore, it is possible to interface any air or molded-case circuit breaker or switch-disconnector, not fitted with a communication module, with the SD-View 2000 supervision system by means of a PLC type ABB AC31. For the circuit-breakers or switch disconnectors connected in this way, SD-View 2000 shows the status of the apparatus (open, closed, tripped, racket-in or racket-out) in real time and allows it to be operated remotely.

All the characteristics of the above mentioned devices are preconfigured in the SD-View 2000 system. The user doesn't have to carry out any detailed configuration (neither to insert tables with the data shown for each trip unit, nor to draw specific graphic pages). It is enough to insert in the system the list of the connected devices.

Technical characteristics

Serial ports	up to 4
ABB SACE devices for each serial port	up to 31
	9600 or 19200 Baud
Protocol	Modbus RTU

Personal computer requirements

Pentium 1 GHz, 512 MB RAM, 100 GB hard disk, Windows 2000 XP, Internet Explorer 6, Ethernet card, RS232 Serial port, USB port (for the license key), Printer (optional).

SD-Pocket

SD-Pocket is an application designed to connect the new protection trip units to a PDA or to a personal computer. This means it is now possible to use wireless communication to:

- configure the protection threshold function;
- monitor measurement functions, including reading of data recorded in data logger (PR332/P or PR333/P);
- verify the status of the circuit-breaker (i.e. number of operations, trip data, according to the trip unit connected).

SD-Pocket application scenarios include:

- during start-up of switchgear, with rapid and error-free transfer of the protection parameters to the trip units (also using the dedicated exchange file directly from Docwin);
- during normal installation service, gathering information on the circuit-breaker and load conditions (last trip information, runtime currents, and other information).

To use all these functions, it is sufficient to have a PDA with MS Windows Mobile 2003 and BT interface or a personal computer with MS Windows 2000/XP OS.

The trip units must be equipped with the PR120/D-BT interface device or PR030. Its use does not require the presence of dialogue units for the trip units. SD-Pocket is freeware and it can be downloaded from the ABB SACE's website (<http://www.abb.com>).

SD-TestBus2

SD-TestBus2 is the commissioning and diagnostic software of ABB SACE for all Modbus RTU devices.

It can be used during system startup, or to troubleshoot an installed network.

SD-TestBus2 automatically scans the RS-485 bus, detects all connected devices and checks their communication settings. All possible combination of device address, parity and baud rate are checked.

A click on “scan” is enough to spot devices which are not responding, wrong addresses, misconfigured parity bits, and so on. This function is not limited to ABB SACE devices: all standard Modbus RTU devices are detected and their configuration is displayed.

After the scan, the software displays warning messages about potential problems and configuration errors, allowing complete diagnosis of a field bus network.

When ABB SACE's circuit-breakers are detected, additional functions can be used to check wirings, send open/ close/reset commands, and retrieve diagnostic information.

This user-friendly tool makes commissioning of Modbus networks a breeze.

SD-TestBus2 can also communicate through a Bluetooth adapter (widcomm compatible) with all the ABB SACE devices equipped with BT030 wireless communication unit.

SD-TestBus2 is freeware and can be downloaded from ABB SACE's website (<http://www.abb.com>).

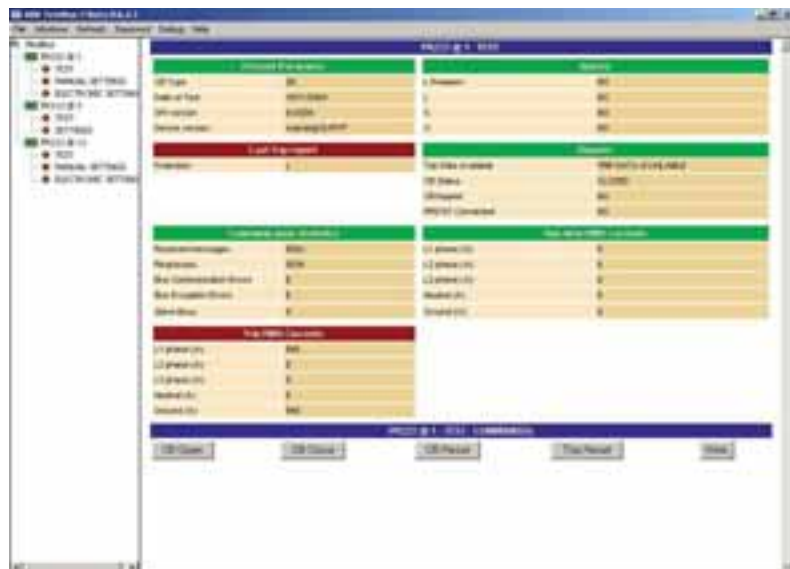

Index

Characteristic curves

Examples of curve readout.....4/2

Trip curves for power distribution

Circuit-breakers with thermomagnetic trip units.....4/3

Circuit-breakers with electronic trip units.....4/7

Trip curves for zone selectivity

Circuit-breakers with PR223EF trip unit.....4/13

Trip curves for motor protection

Circuit-breakers with magnetic only trip units.....4/14

Circuit-breakers with PR221DS, PR231/P e PR221MP electronic trip units4/15

Use of the trip curves of circuit-breakers with PR222MP electronic trip unit4/16

Circuit-breakers with PR222MP electronic trip unit4/18

Specific let-through energy curves ⁽¹⁾

230 V4/19

400-440 V4/21

500 V4/23

690 V4/25

1000 V4/27

1150 V4/28

Limitation curves ⁽¹⁾

230 V4/29

400-440 V4/31

500 V4/33

690 V4/35

1000 V4/37

1150 V4/38

Technical information

Temperature performances

Circuit-breakers with magnetic only or electronic trip units and switch-disconnectors4/39

Circuit-breakers with thermomagnetic trip units4/57

Power losses.....4/59

Magnetic trip values.....4/60

Special applications

Use of apparatus at 16 2/3Hz4/61

Use of apparatus at 400 Hz.....4/64

Use of direct current apparatus.....4/67

Zone selectivity4/76

⁽¹⁾ For T1 1p and T2 with PR221DS, please ask ABB SACE directly.

Examples of curve readout

Example 1 - T4N 250

Trip curves for power distribution (thermomagnetic trip unit)

Considering a T4N 250 $I_n = 250$ A circuit-breaker. By means of the thermal adjustment trimmer, the current threshold I_1 is selected, for example at $0.9 \times I_n$ (225 A); the magnetic trip threshold I_3 , adjustable from 5 to $10 \times I_n$, we select at $10 \times I_n$, equal to 2500 A.

It can be noted that, on the basis of the conditions in which the overload is presented, i.e. with the circuit-breaker at thermal running or not, the thermal relay trip varies considerably. For example, for an overload current of $2 \times I_1$, the trip time is between 21.4 and 105.3 s for hot trip, and between 105.3 and 357.8 s for cold trip.

For fault current values higher than 2500 A, the circuit-breaker trips instantaneously with the magnetic protection.

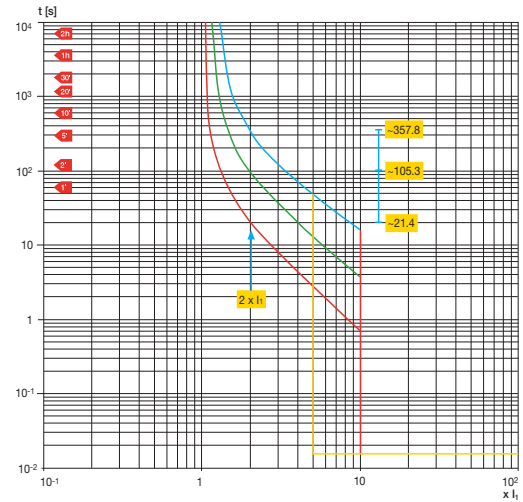

1SDC210E01FD001

Example 2 - T2S 160

Limitation curves

The following figure shows the trend of the Tmax T2S 160, $I_n = 160$ A circuit-breaker current-limiting curve. The r.m.s. of the prospective symmetrical short-circuit current is indicated on the abscissa of the diagram, whereas the peak short-circuit current value is indicated on the ordinates. The current-limiting effect can be assessed by comparing - at the same symmetrical short-circuit current value, the corresponding peak value at the prospective short-circuit current (curve A) with the limited peak value (curve B). The T2S 160 circuit-breaker with thermomagnetic trip unit $I_n = 160$ A at a voltage of 400 V limits the short-circuit current to 16.2 kA for a fault current of 40 kA, with a reduction of about 68 kA compared with the peak value of the 84 kA prospective short-circuit current.

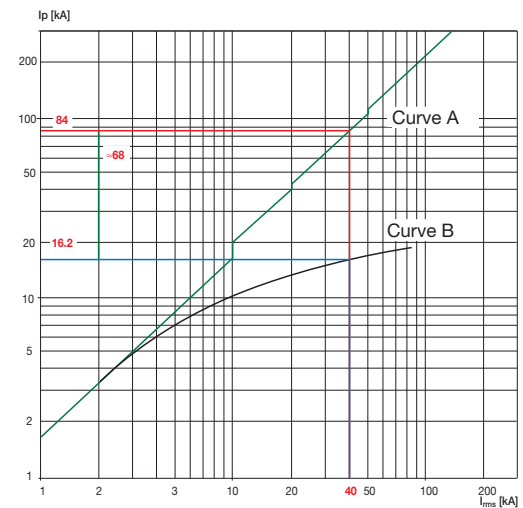

1SDC210E02FD001

Example 3 - T3S 250

Specific let-through energy curves

An example of reading the graph of the specific let-through energy curve of the T3S 250 $I_n = 160$ A circuit-breaker at a voltage of 400 V is given below.

The prospective symmetrical short-circuit current is indicated on the abscissa of the diagram, whereas the ordinates show the specific let-through energy values expressed in A^2s .

In correspondence with a short-circuit current of 20 kA, the circuit-breaker lets through a value of I^2t equal to $1.17 \cdot 10^6 \cdot A^2s$.

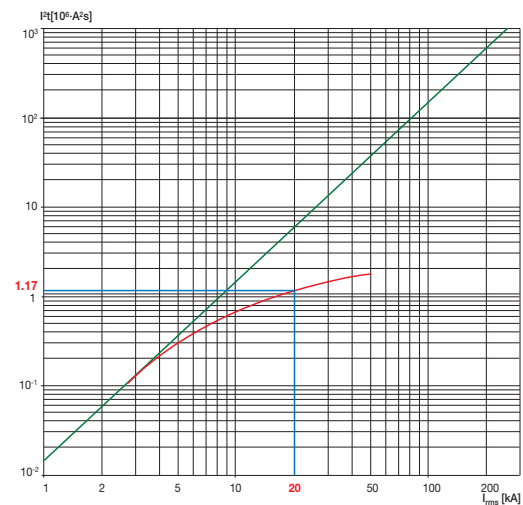

1SDC210E03FD001

Abbreviations used

- I_n = rated current of the thermomagnetic or electronic trip unit
- I_1 = set trip current for overload
- I_3 = trip current for short-circuit
- I_{rms} = prospective symmetrical short-circuit current

Trip curves for power distribution

Circuit-breakers with thermomagnetic trip units

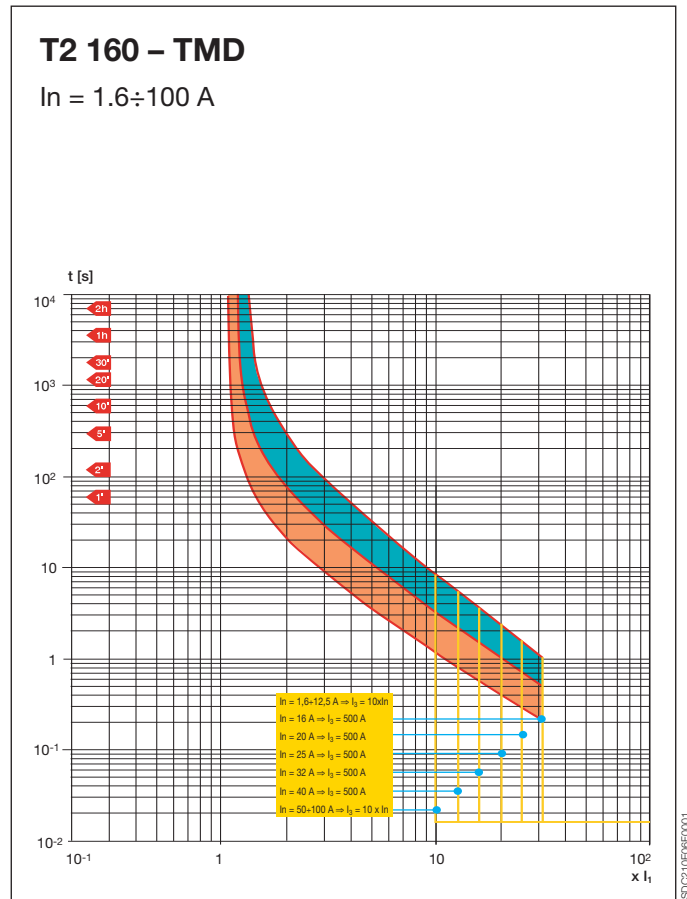
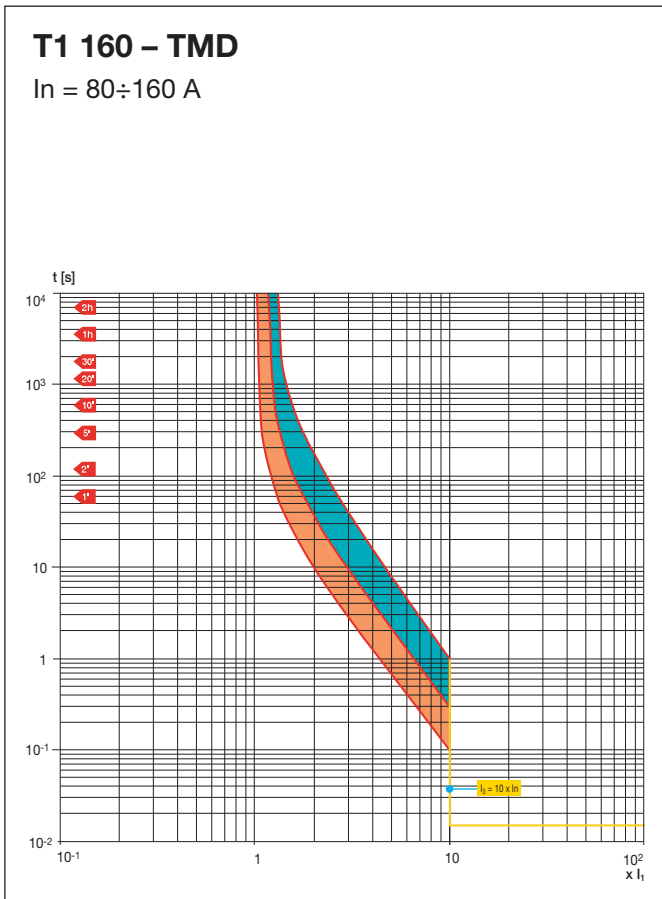
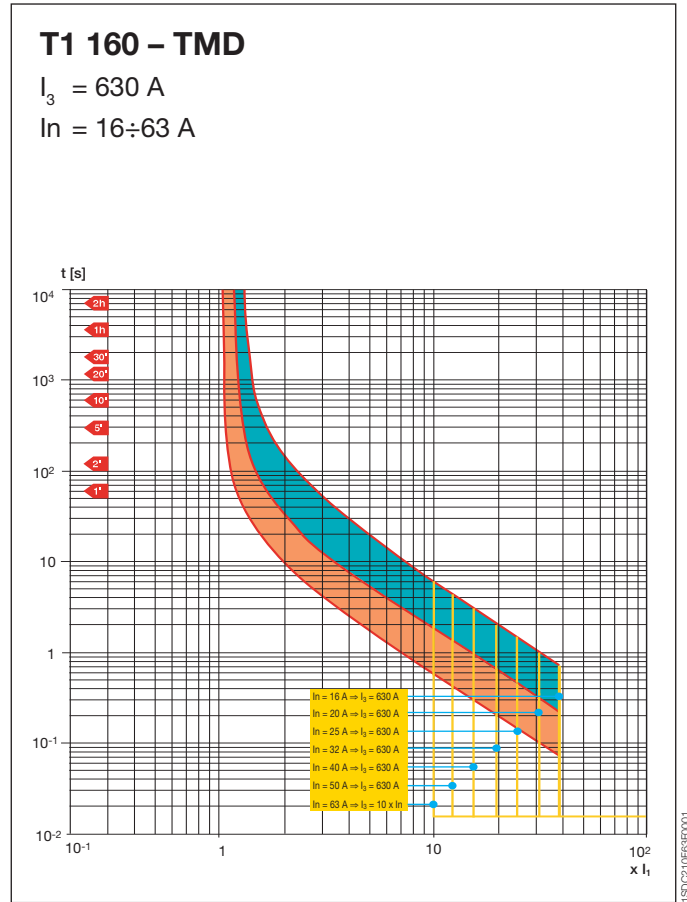
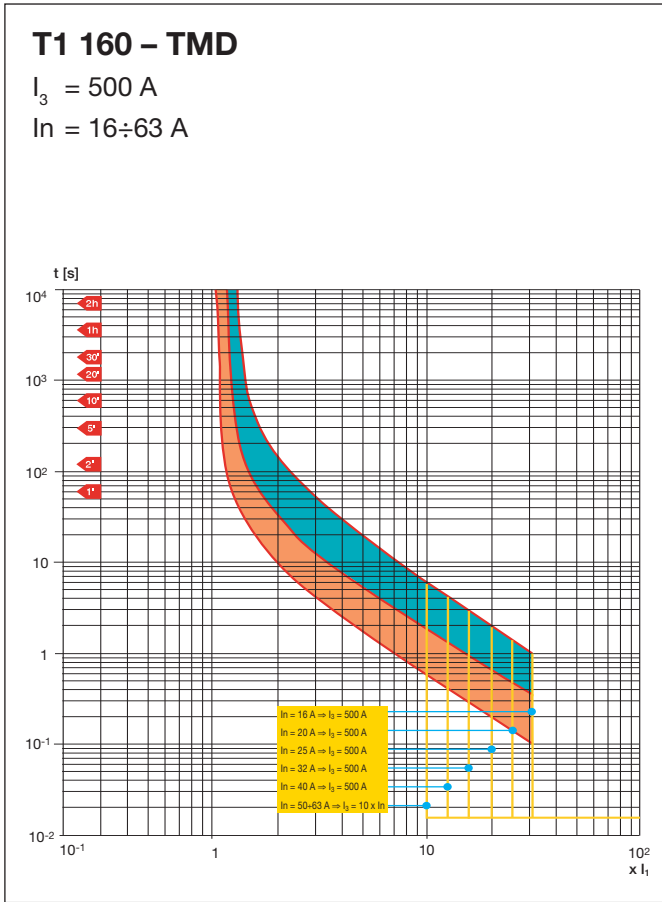

Trip curves for power distribution

Circuit-breakers with thermomagnetic trip units

T2 160 – TMD

$I_n = 125 \text{ A}$

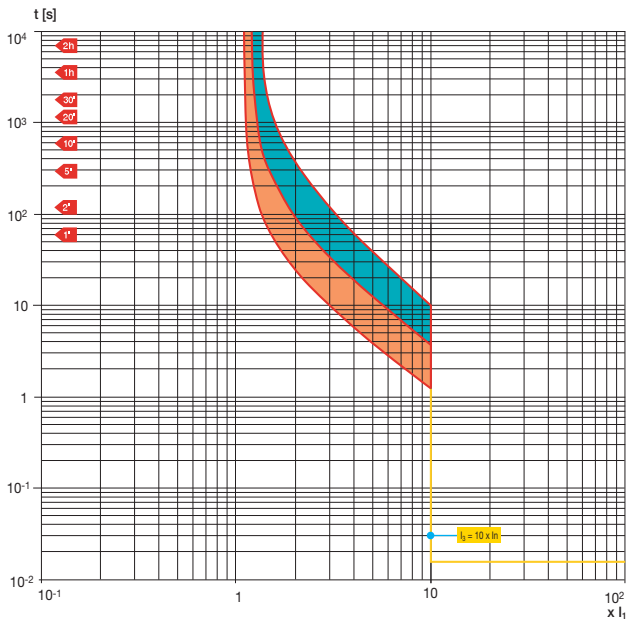

1SDC210607F0001

T2 160 – TMD

$I_n = 160 \text{ A}$

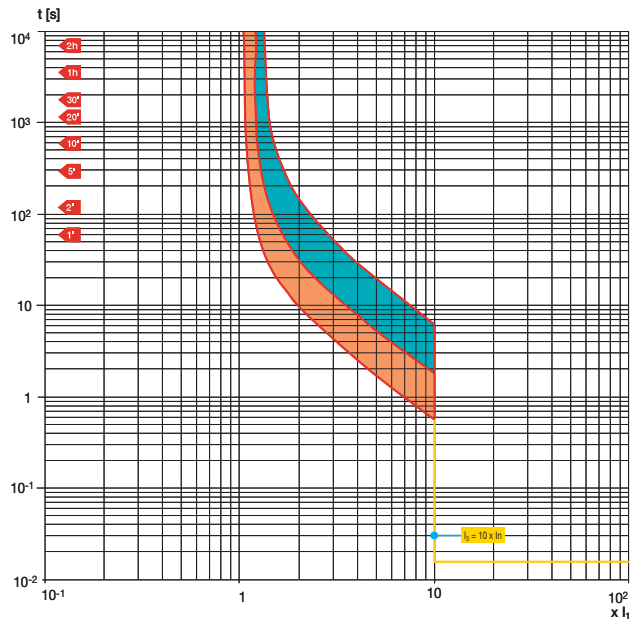

1SDC210607F0001

T2 160 – TMG

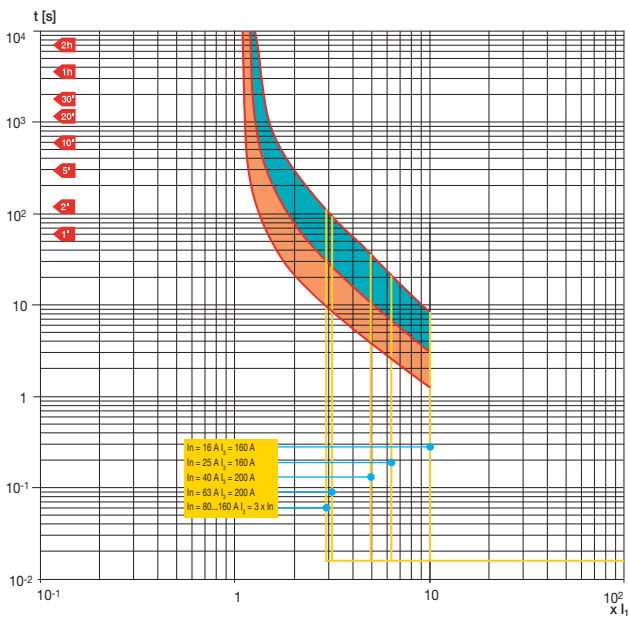

1SDC210608F0001

T3 250 – TMD

$I_n = 63 \div 250 \text{ A}$

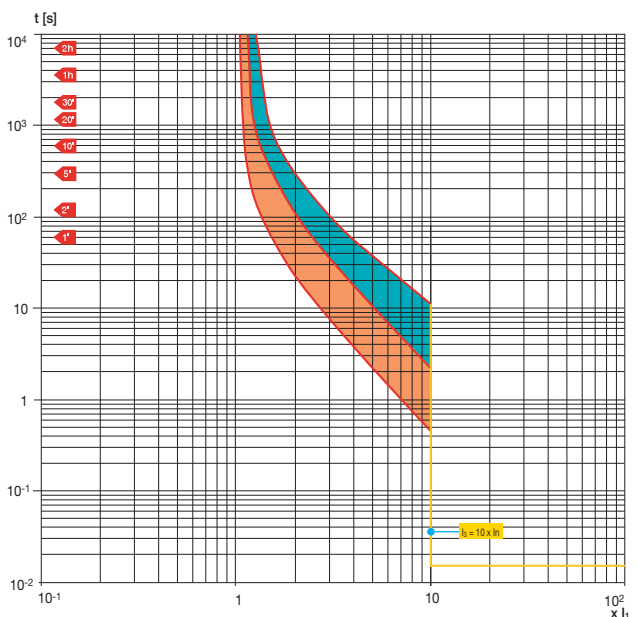

1SDC210609F0001

T3 250 – TMG

$I_n = 63 \div 250 \text{ A}$

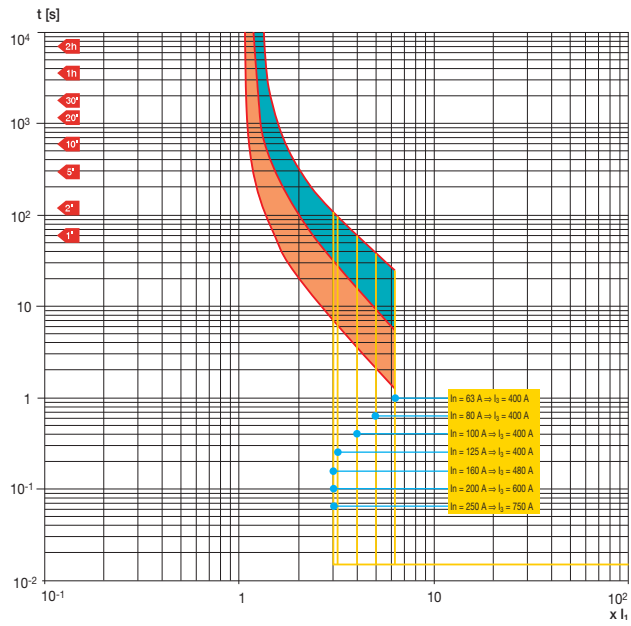

1SDC210E11P0001

T4 250 – TMD

$I_n = 20 \div 50 \text{ A}$

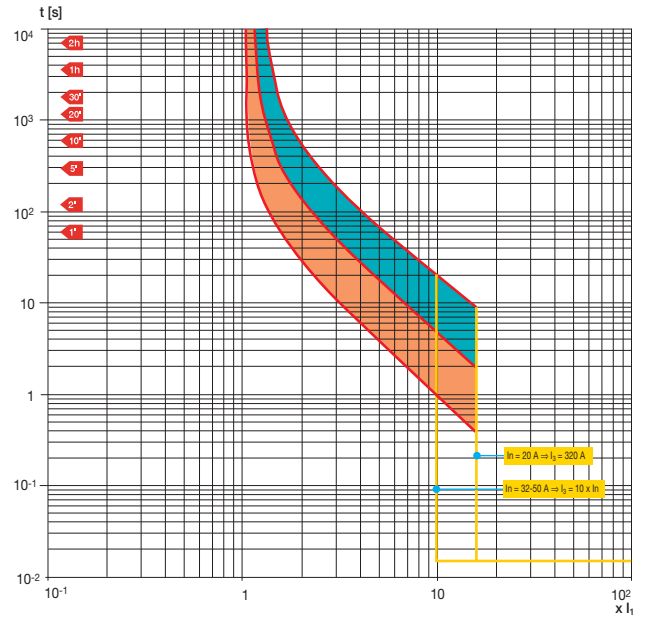

1SDC210E11P0001

T4 250/320 – TMA

$I_n = 80 \div 250 \text{ A}$

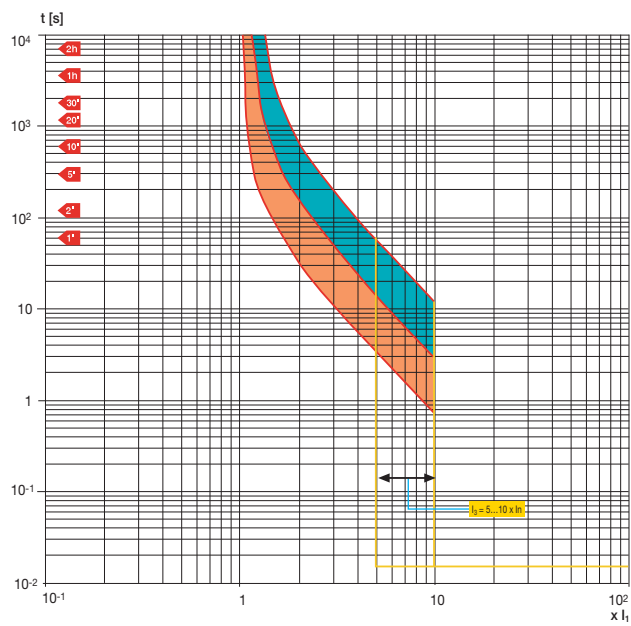

1SDC210E12P0001

T5 400/630 – TMA

$I_n = 320 \div 500 \text{ A}$

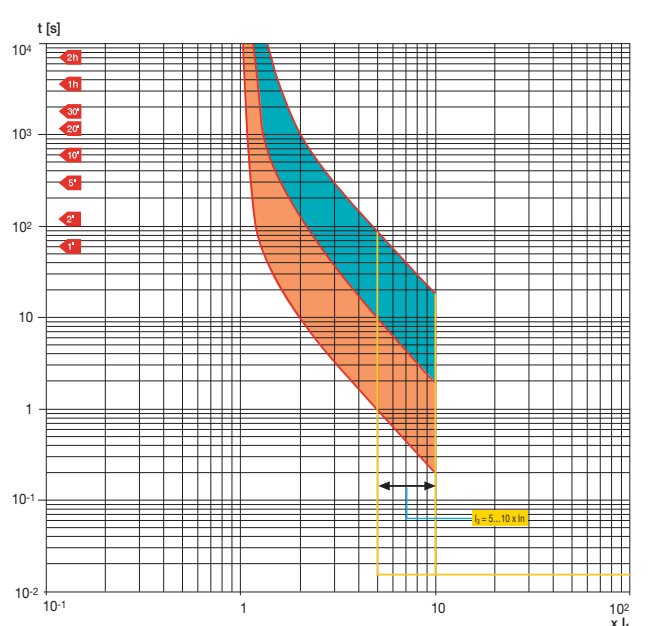

1SDC210E13P0001

Trip curves for power distribution

Circuit-breakers with thermomagnetic trip units

T5 400/630 – TMG

$I_n = 320 \div 500 \text{ A}$

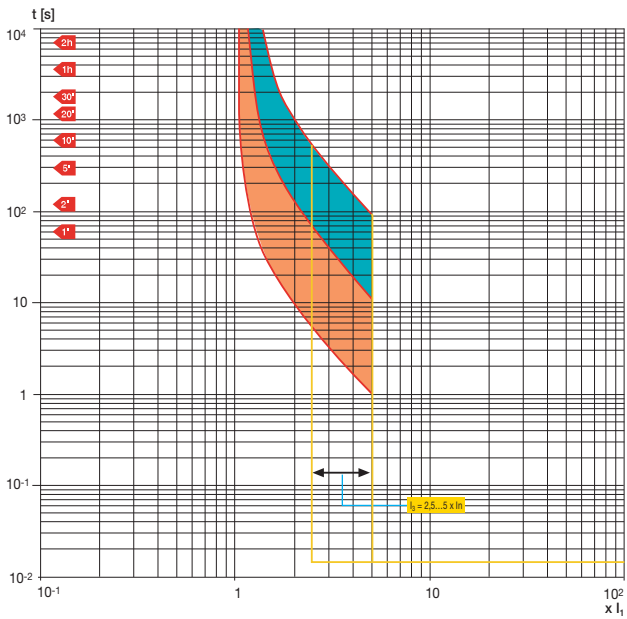

1SDC210E14F0001

T6 630 – TMA

$I_n = 630 \text{ A}$

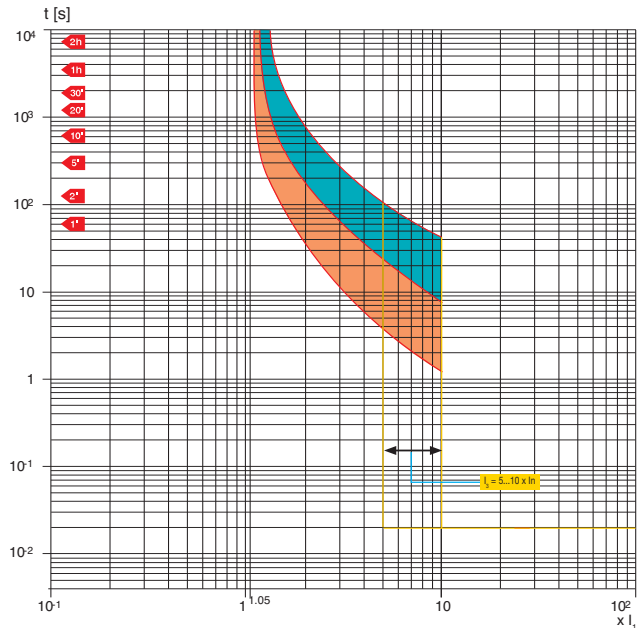

1SDC210E15F0001

T6 800 – TMA

$I_n = 800 \text{ A}$

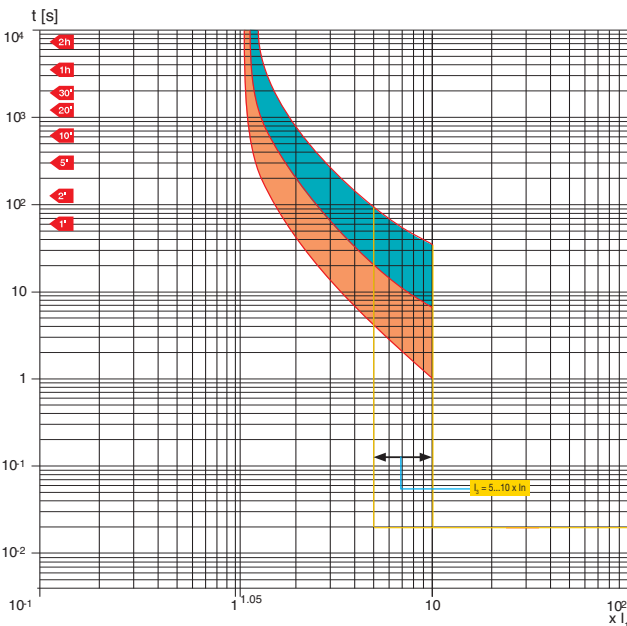

1SDC210E16F0001

4

Trip curves for power distribution

Circuit-breakers with electronic trip units

T4 250/320 - T5 400/630 - T6 630/800/1000 PR21DS

L-S Functions

Note: For T4 $I_n = 320$ A, T5 $I_n = 630$ A and T6 $I_n = 1000$ A $\Rightarrow I_{p,max} = 9.5 \times I_n$

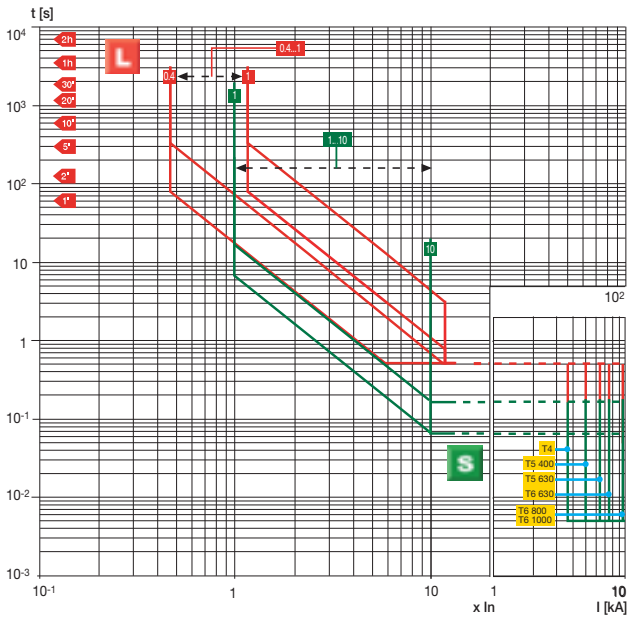

1SDC210E21F0001

T4 250/320 - T5 400/630 - T6 630/800/1000 PR22DS - PR22DS/PD - PR223DS

L-S-I Functions

Note: The dotted curve of function L corresponds to the maximum delay (t_L) which can be set at $6 \times I_{p,max}$ in the case where 320 A CTs are used for T4 and 630 A for T5. For all the CT sizes $t_L = 18$ s except with 320 A CT (T4), 630 A CT (T5) and 1000 A CT (T6) where $t_L = 10.5$ s. For T4 $I_n = 320$ A, T5 $I_n = 630$ A and T6 $I_n = 1000$ A $\Rightarrow I_{p,max} = 9.5 \times I_n$. For T6 $I_n = 800$ A $\Rightarrow I_{p,max} = 10.5 \times I_n$. For PR223DS the L protection function can be set to $I_L = 0.18 \dots 1 \times I_n$.

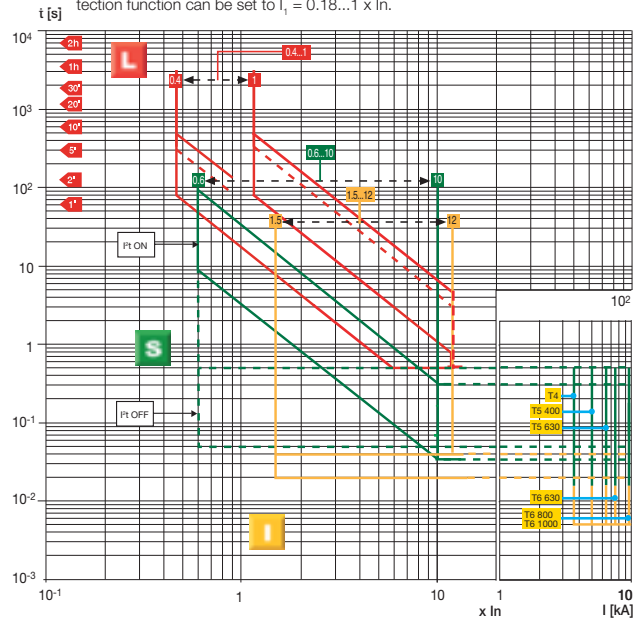

1SDC210E21F0001

T4 250/320 - T5 400/630 - T6 630/800/1000 PR22DS - PR22DS/PD - PR223DS

G Function

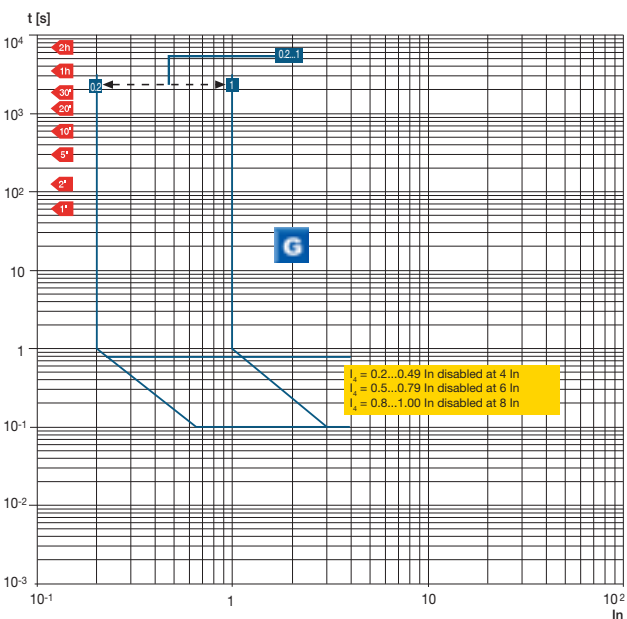

1SDC210E22F0001

T7 800/1000/1250/1600 - PR231/P

L-I Functions

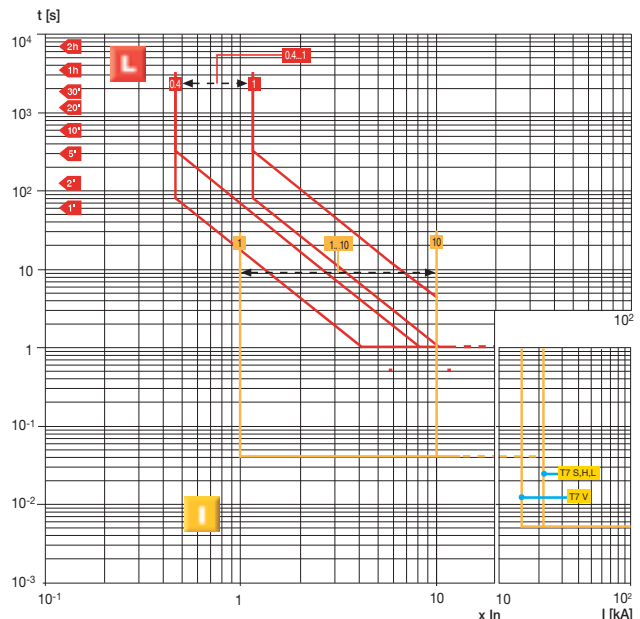

1SDC210E28F0001

Trip curves for power distribution

Circuit-breakers with electronic trip units

T7 800/1000/1250/1600 PR332/P with PR330/V

UV Function

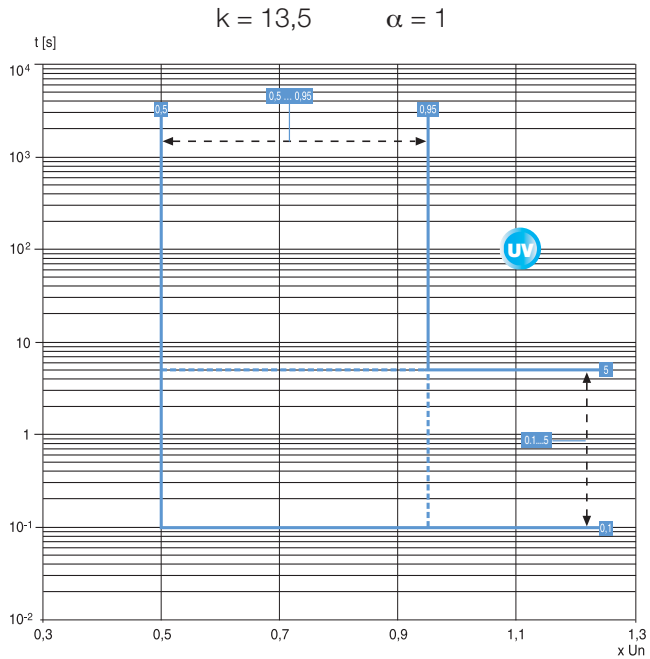

T7 800/1000/1250/1600 PR332/P with PR330/V

OV Function

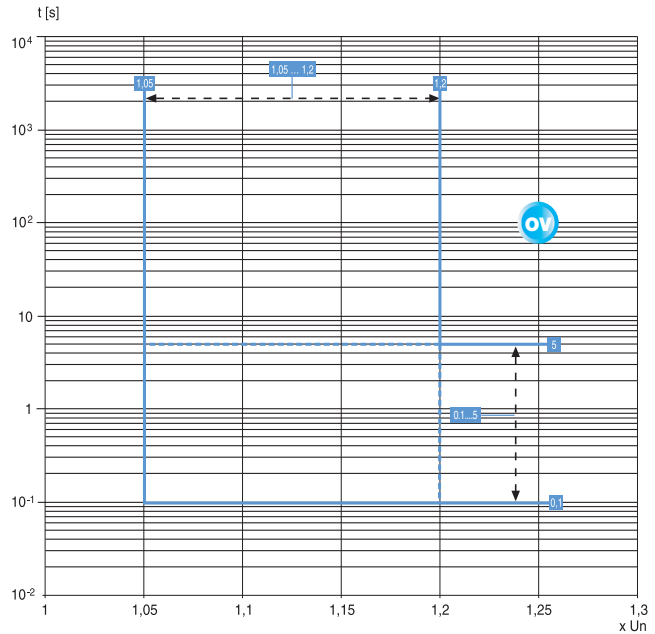

T7 800/1000/1250/1600 PR332/P with PR330/V

RV Function

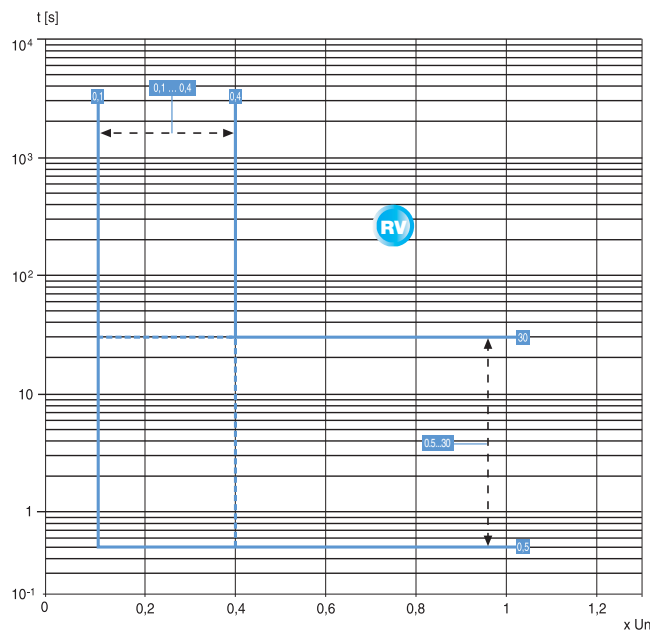

T7 800/1000/1250/1600 PR332/P with PR330/V

RP Function

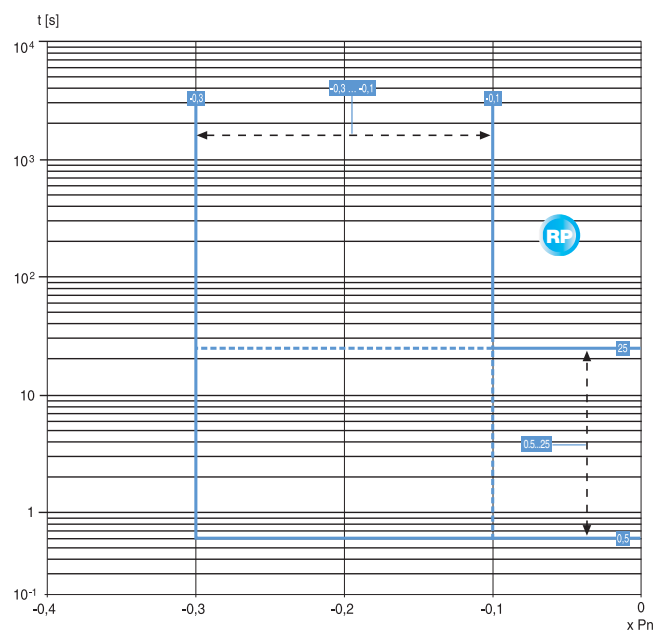

Trip curves for zone selectivity

Circuit-breakers with PR223EF trip unit

T4L 250/320 - T5L 400/630 - T6L 630/800/1000 PR223EF - Vaux ON

L-S-EF Functions

Note: The dotted curve of function L corresponds to the maximum delay (t_1) which can be set at $6 \times I_n$, in the case where 320 A CTs are used for T4 and 630 A for T5. For all the CT sizes $t_1 = 18$ s except with 320 A CT (T4), 630 A CT (T5) and 1000 A CT (T6) where $t_1 = 10.5$ s. For T4 $I_n = 320$ A, T5 $I_n = 630$ A and T6 $I_n = 1000$ A $\Rightarrow I_{p,max} = 9.5 \times I_n$ and $I_{r,max} = 9.5 \times I_n$. For T6 $I_n = 800$ A $\Rightarrow I_{p,max} = 10.5 \times I_n$.

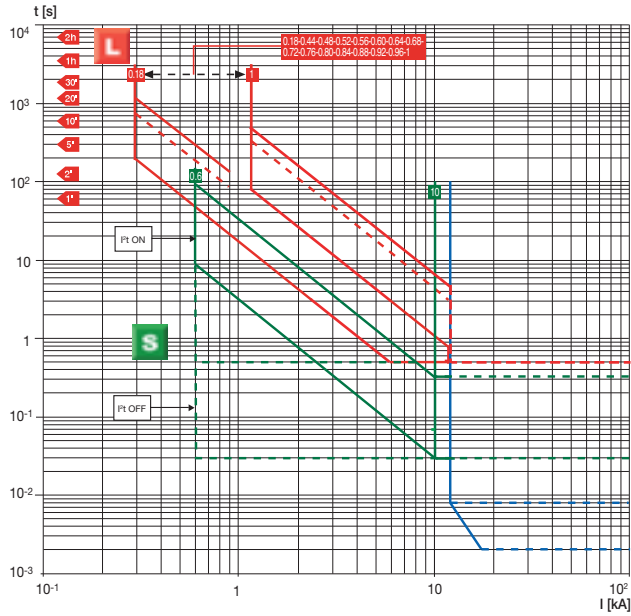

T4L 250/320 - T5L 400/630 - T6L 630/800/1000 PR223EF - Vaux OFF

L-S-I Functions

Note: The dotted curve of function L corresponds to the maximum delay (t_1) which can be set at $6 \times I_n$, in the case where 320 A CTs are used for T4 and 630 A for T5. For all the CT sizes $t_1 = 18$ s except with 320 A CT (T4), 630 A CT (T5) and 1000 A CT (T6) where $t_1 = 10.5$ s. For T4 $I_n = 320$ A, T5 $I_n = 630$ A and T6 $I_n = 1000$ A $\Rightarrow I_{p,max} = 9.5 \times I_n$ and $I_{r,max} = 9.5 \times I_n$. For T6 $I_n = 800$ A $\Rightarrow I_{p,max} = 10.5 \times I_n$.

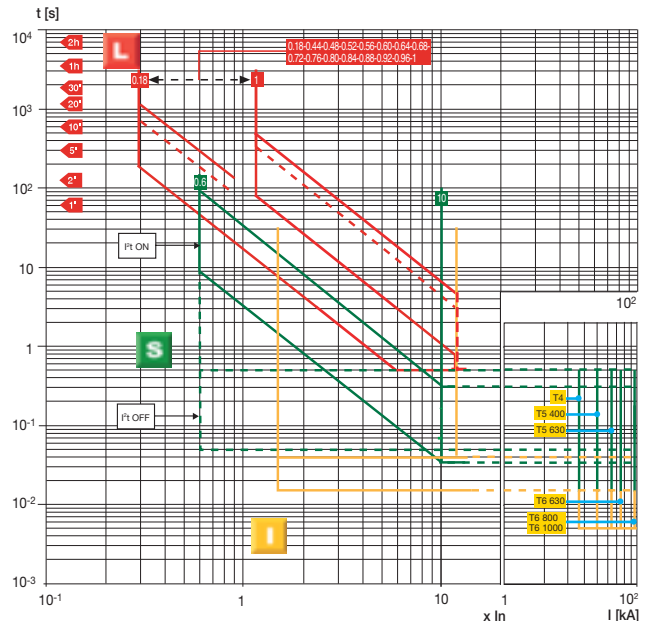

T4L 250/320 - T5L 400/630 - T6L 630/800/1000 PR223EF - Vaux ON/OFF

G Function

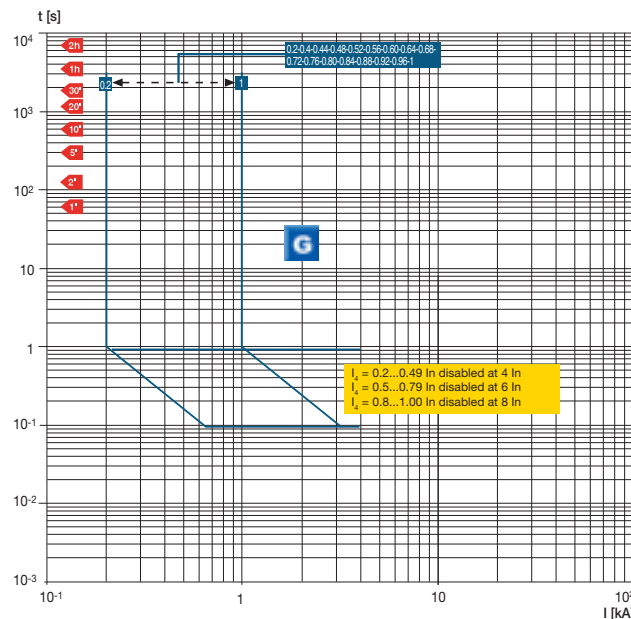

Trip curves for motor protection

Circuit-breakers with magnetic only trip units

T2 160 – MF

$$I_3 = 13 \times I_n$$

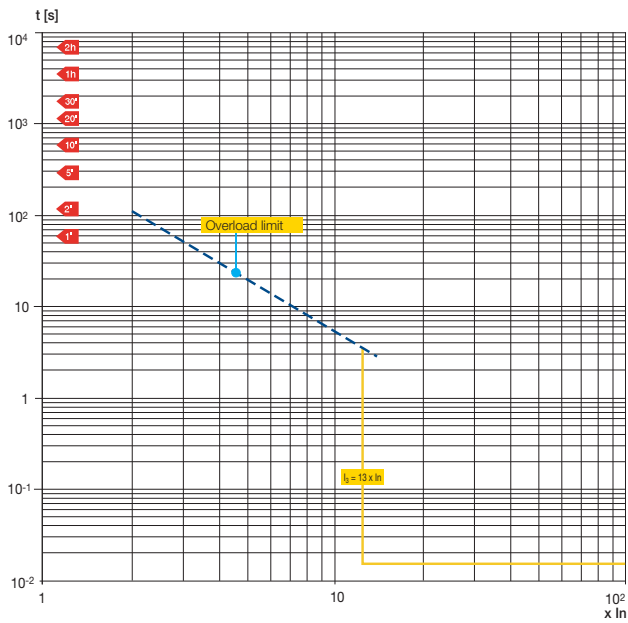

1SDC210227F0001

T2 160 - T3 250 – MA

$$I_3 = 6 \dots 12 \times I_n$$

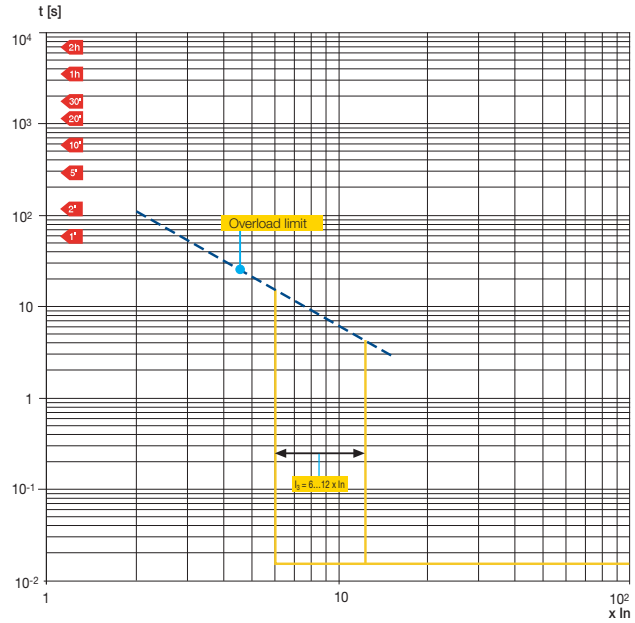

1SDC210228F0001

T4 250 – MA

$$I_3 = 6 \dots 14 \times I_n$$

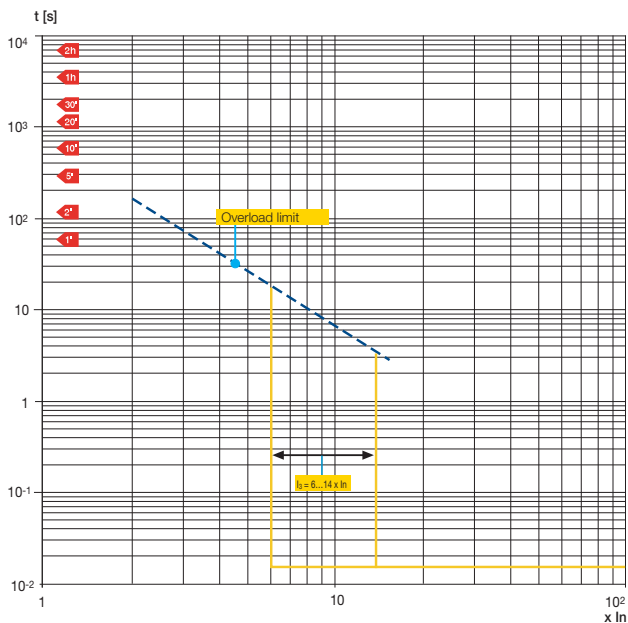

1SDC210229F0001

Trip curves for motor protection

Circuit-breakers with PR221DS, PR231/P and PR221MP electronic trip unit

T2 160 – PR221DS-I

I Function

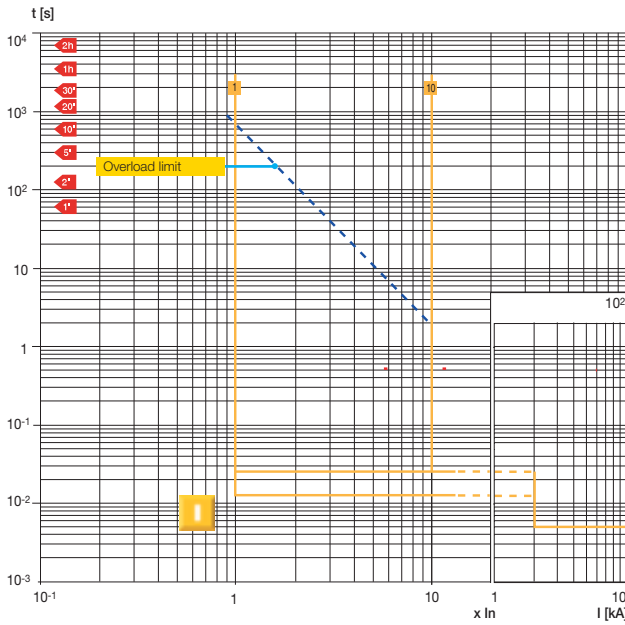

T4 250/320 - T5 400/630 - T6 630/800 PR221DS-I

I Function

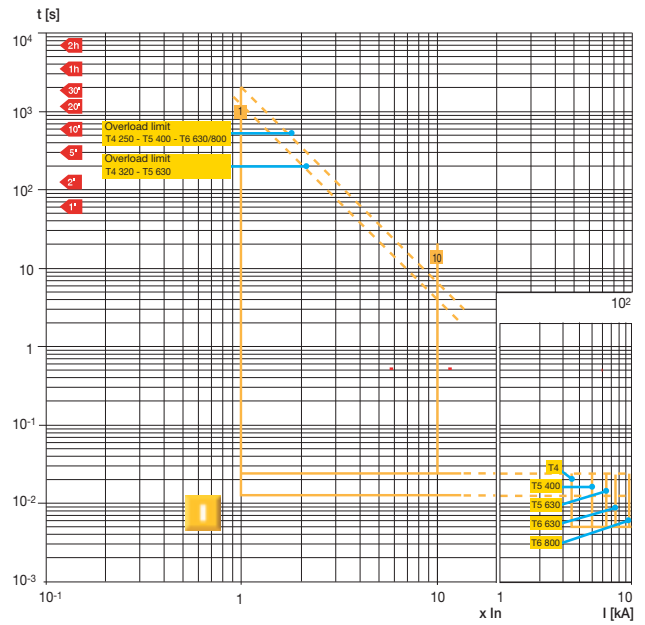

T7 800/1000/1250 – PR231/P-I

I Function

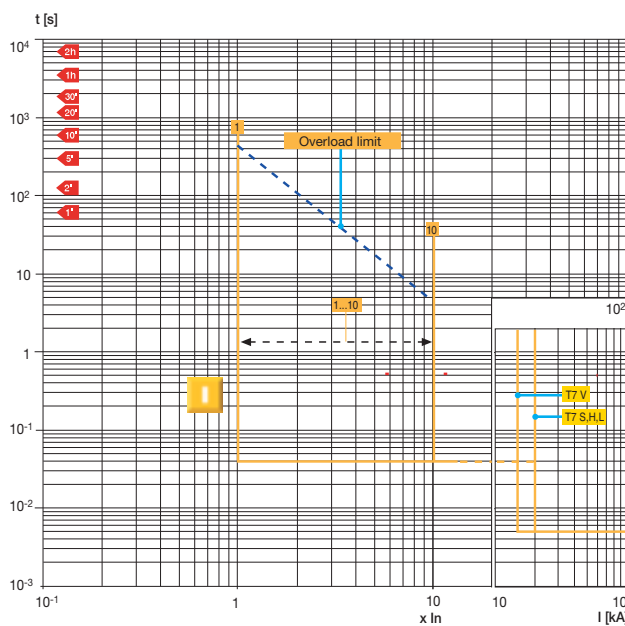

T2 100 – PR221MP

L-I Functions

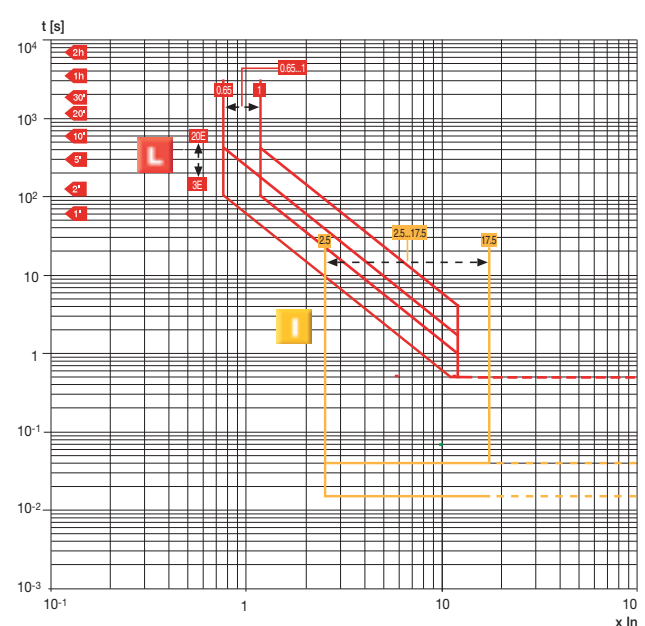

Trip curves for motor protection

Use of the trip curves of circuit-breakers with PR222MP electronic trip unit

For correct parameter setting of the SACE PR222MP electronic trip unit, it may be useful to compare the overall circuit-breaker curve with the motor starting curve.

For this purpose, with the protection function graphics shown on the following pages, it is possible to draw the overall curve required for the circuit-breaker fitted with SACE PR222MP trip unit simply and immediately.

N.B. For function L, as for all the other functions, make sure you place a glossy tracing sheet over the curve so that the times on the axis of the co-ordinates coincide.

Function L (cannot be excluded)

Protection against overload

To protect the motor against any overloads, as a first step it is necessary to adjust function L to a current I_1 higher than or equal to the rated current of the motor I_e : $I_1 \geq I_e$.

For example, if $I_e = 135$ A, an T4 250 circuit-breaker can be selected with $I_n = 160$ A and the following adjustment carried out: $I_1 = 0.85 \times I_n = 136$ A.

The second step is to select the trip class according to the motor starting time. For a motor with a start-up overload of 6 seconds, class 10 can be selected, with a trip time of 8s at $7.2 \times I_1$.

To trace the curve correctly on the glossy sheet, according to I/I_n , simply place the glossy sheet over the graph of function L so that $I/I_n = 0.85$ (on the glossy sheet) corresponds to $I/I_1 = 1$ (on the graph) and draw the curve relative to class 10.

Function R (can be excluded)

Protection against rotor blockage

Protection against rotor blockage can be set both with regard to the trip current $I_5 = 3 \dots 10 \times I_1$ (in this case $I_5 = 3 \dots 10 \times 0.85 \times 160$), and with regard to the trip time t_5 .

To trace the curve correctly on the glossy sheet, simply place the glossy sheet over the graph of function R so that $I/I_n = I_1/I_n$ (on the glossy sheet) corresponds to $I/I_1 = 1$ (on the graph). In this case $I/I_n = I_1/I_n = 0.85$, and draw the desired curve.

Function I (cannot be excluded)

Protection against short-circuit

This protection function against short-circuit recognises whether the motor is in the starting phase, thereby avoiding unwarranted trips; the trip threshold can be set from $6 \times I_n$ to $13 \times I_n$.

To trace the curve correctly on the glossy sheet, simply place the glossy sheet over the graph of function I so that $I/I_n = 1$ (on the glossy sheet) corresponds to $I/I_n = 1$ (on the graph) and draw the desired curve.

Function U (can be excluded)

Protection against loss and/or unbalance of a phase

Protection against loss or unbalance of a phase, if set to ON, intervenes when one or two phases have a current lower than $0.4 \times I_1$ ($0.4 \times 0.85 \times I_n = 0.4 \times 0.85 \times 160$ A = 54.4 A in this case).

To trace the curve correctly on the glossy sheet, simply place the glossy sheet over the graph of function U so that $I/I_n = I_1/I_n$ (on the glossy sheet) corresponds to $I/I_1 = 1$ (on the graph). In this case $I/I_n = I_1/I_n = 0.85$, and draw the desired curve.

Characteristic operating curve of an asynchronous motor

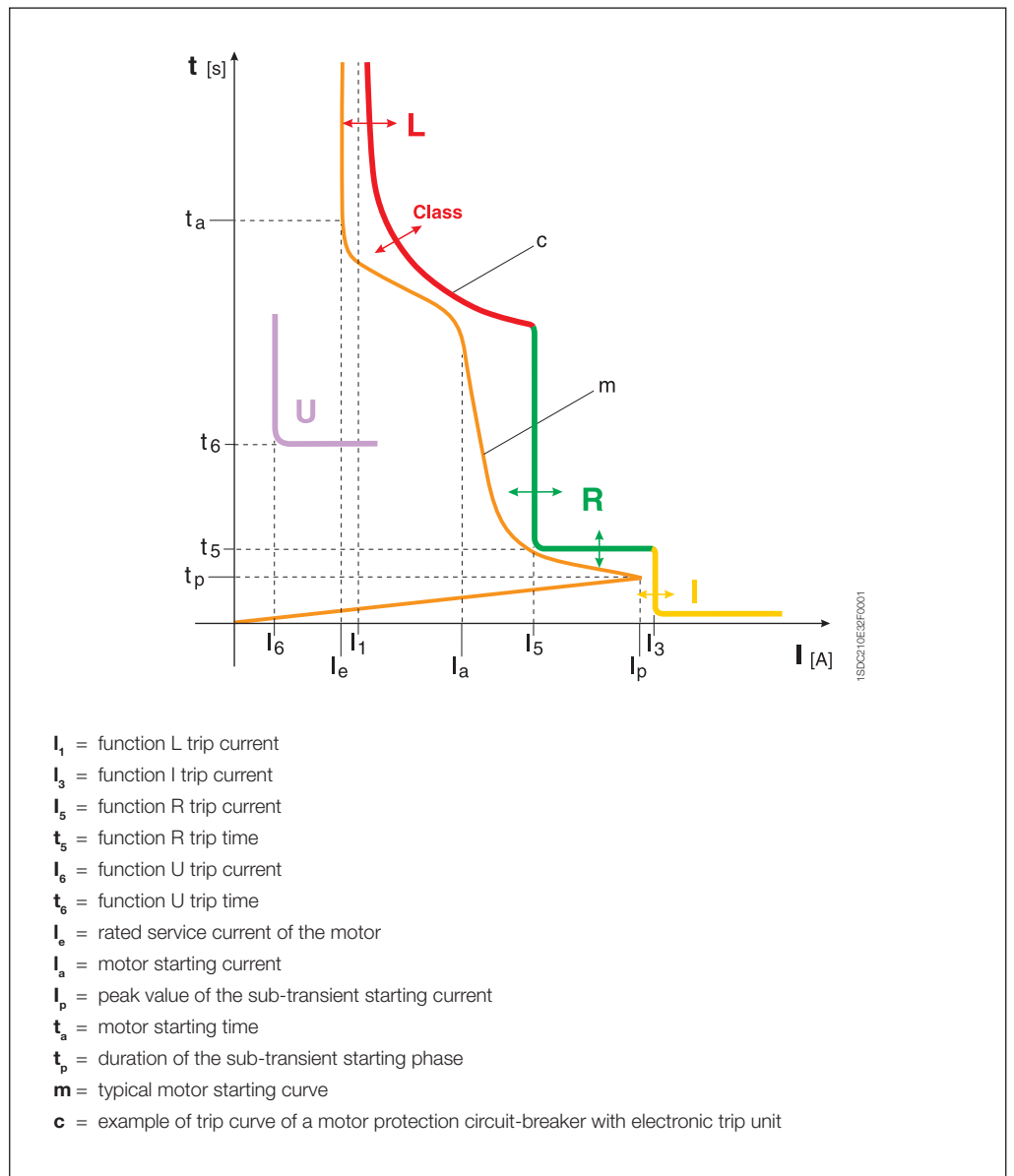

Trip curves for motor protection

Circuit-breakers with PR222MP electronic trip unit

T4 250 - T5 400 - T6 800 - PR222MP

L Function (hot and cold trip)

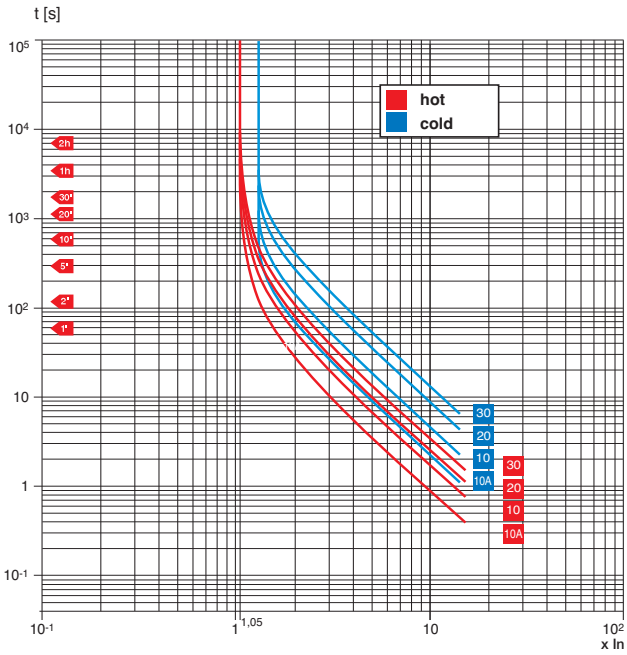

1SDC210E39F0001

T4 250 - T5 400 - T6 800 - PR222MP

L Function (hot trip with 1 or 2 phases supplied)

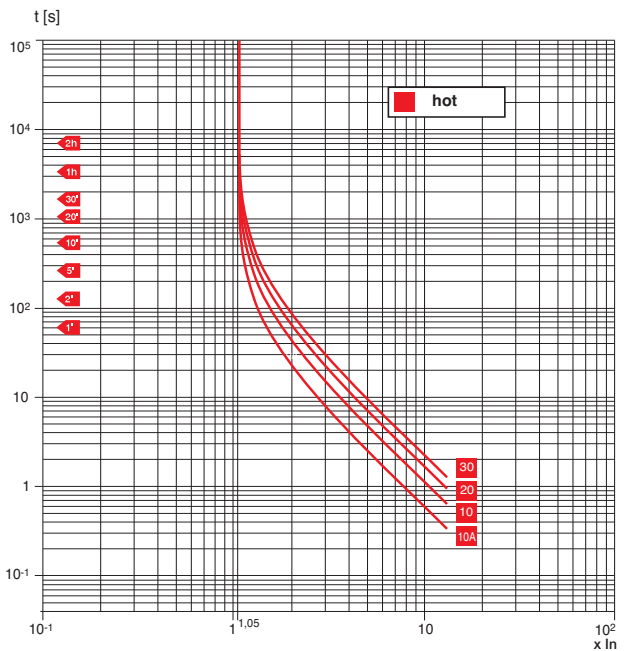

1SDC210E39F0001

T4 250 - T5 400 - T6 800 - PR222MP

R-U Functions

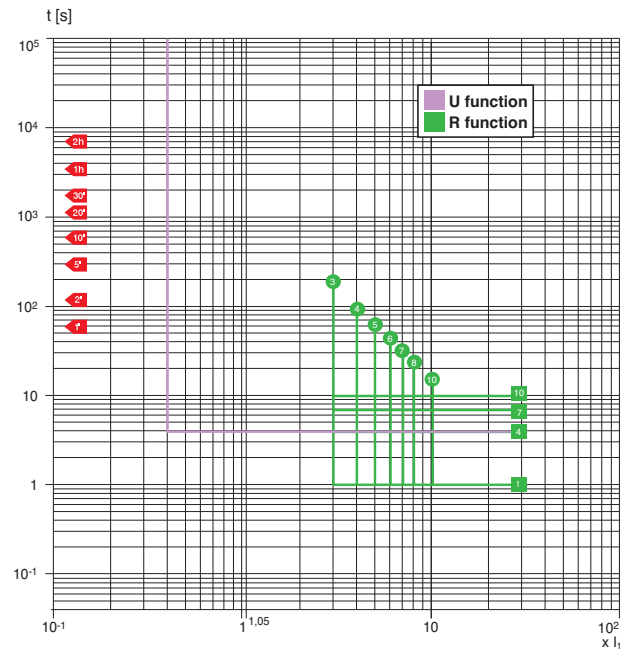

1SDC210E39F0001

T4 250 - T5 400 - T6 800 - PR222MP

I Function

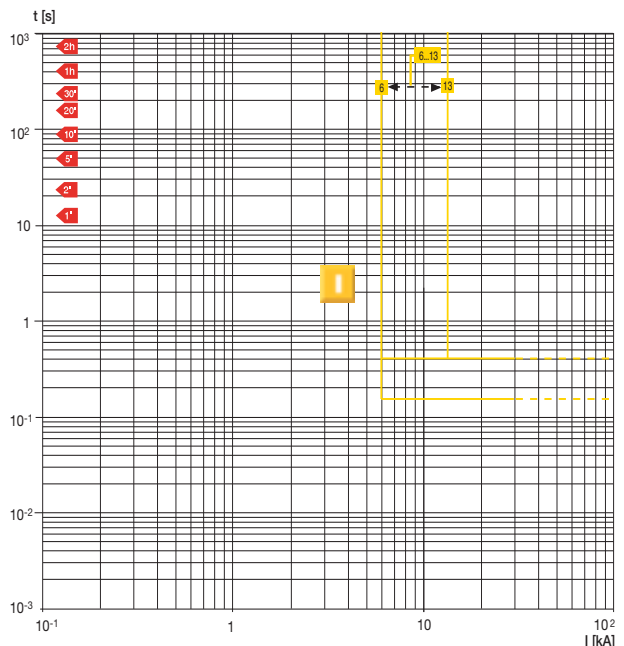

1SDC210E39F0001

Specific let-through energy curves

T1 160

230 V

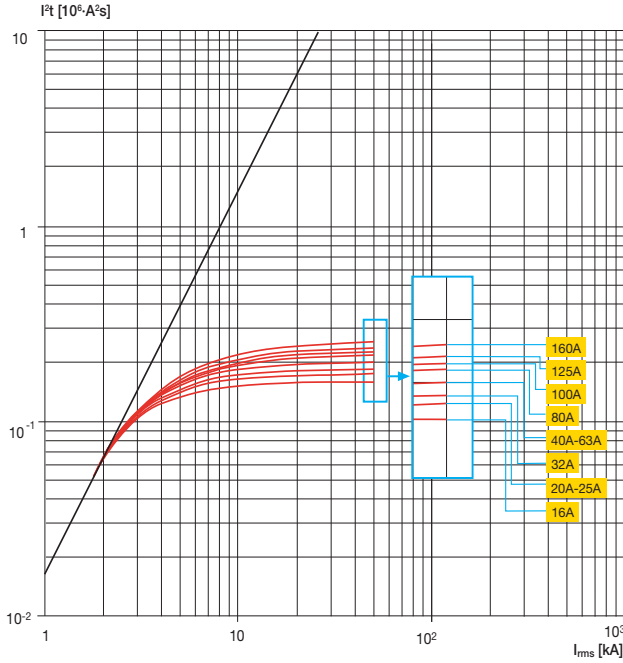

1SDC210E37F0001

T2 160

230 V

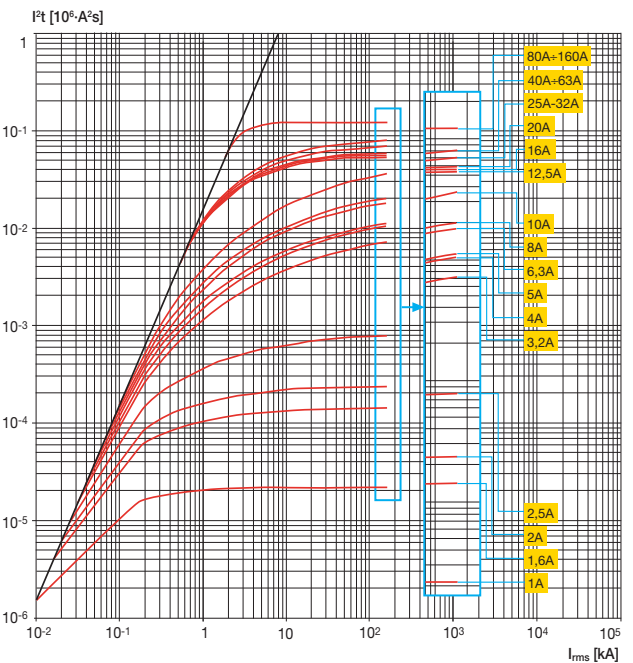

1SDC210E38F0001

T3 250

230 V

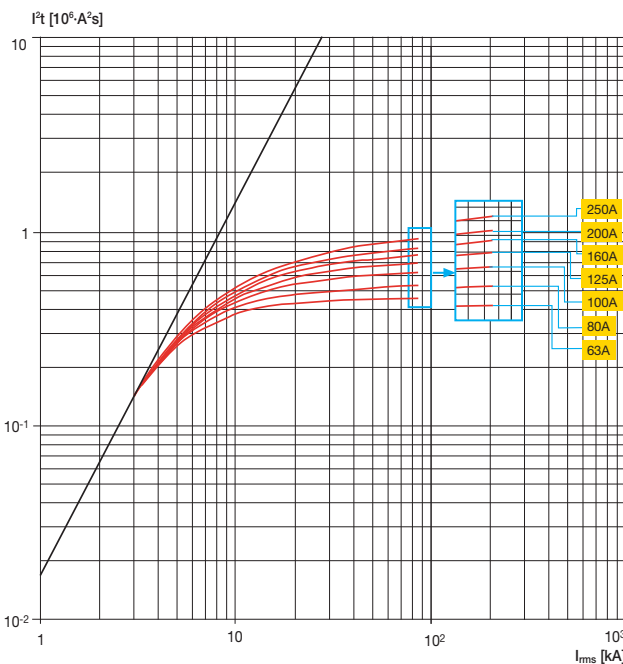

1SDC210E39F0001

T4 250/320

230 V

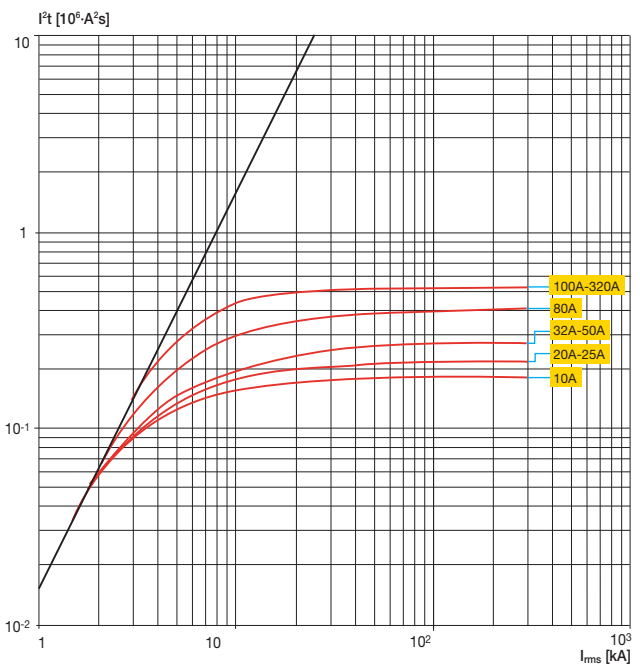

1SDC210E40F0001

Specific let-through energy curves

T5 400/630

230 V

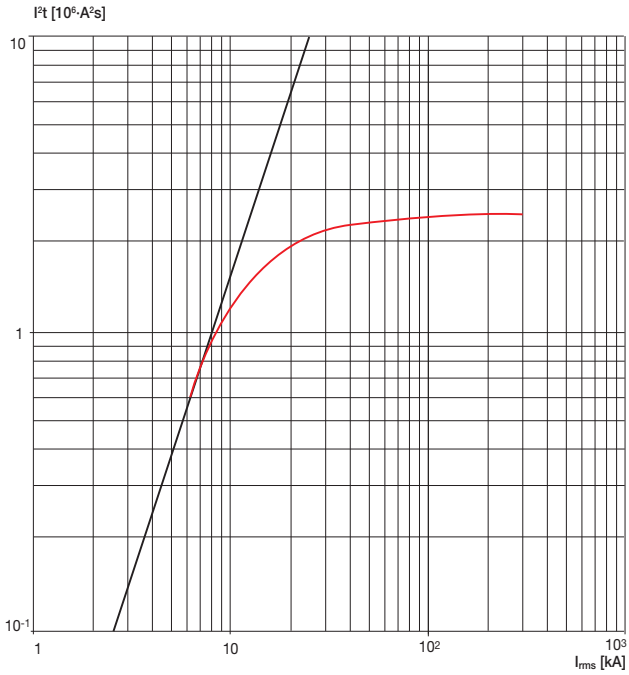

1SDC210541F0001

T6 630/800/1000

230 V

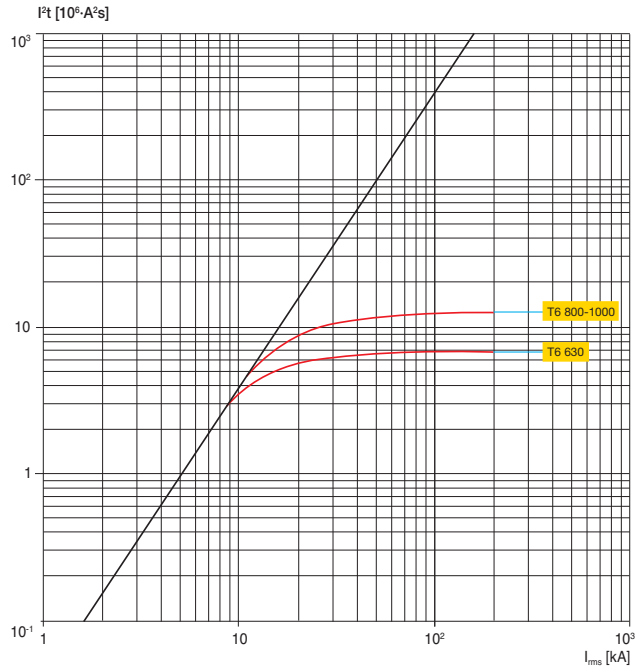

1SDC210542F0001

T7 800/1000/1250/1600

230 V

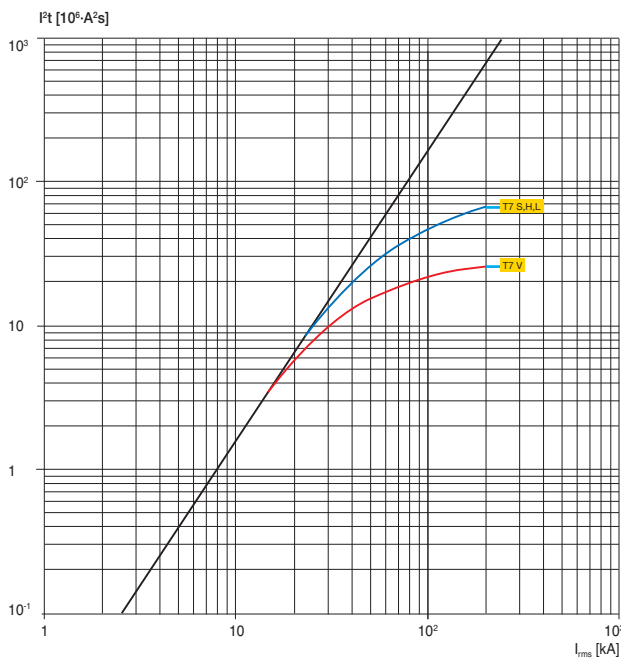

1SDC210540F0001

T1 160

400-440 V

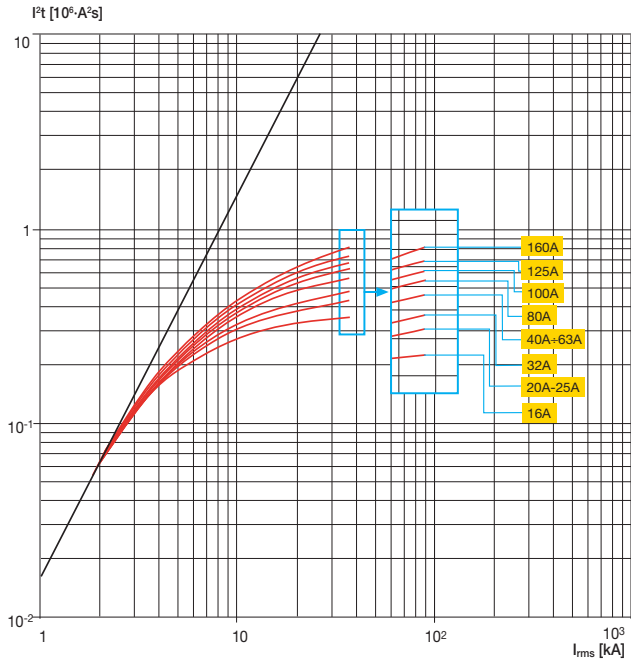

1SDC210E44F0001

T2 160

400-440 V

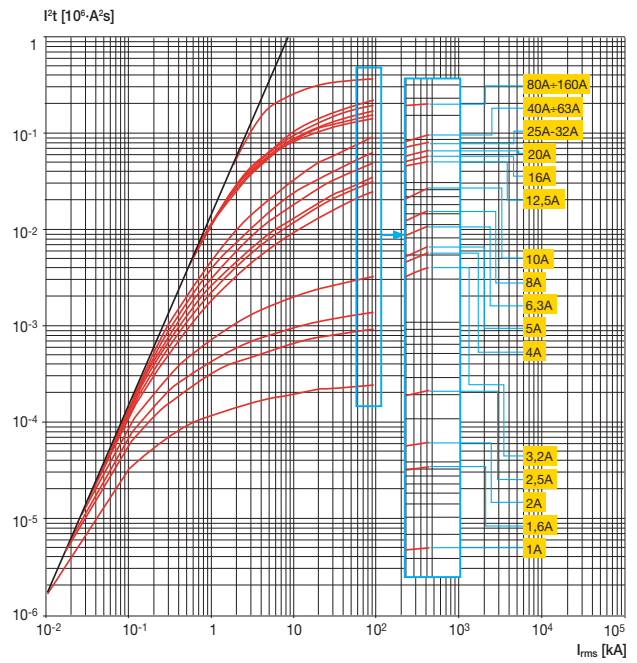

1SDC210E44F0001

T3 250

400-440 V

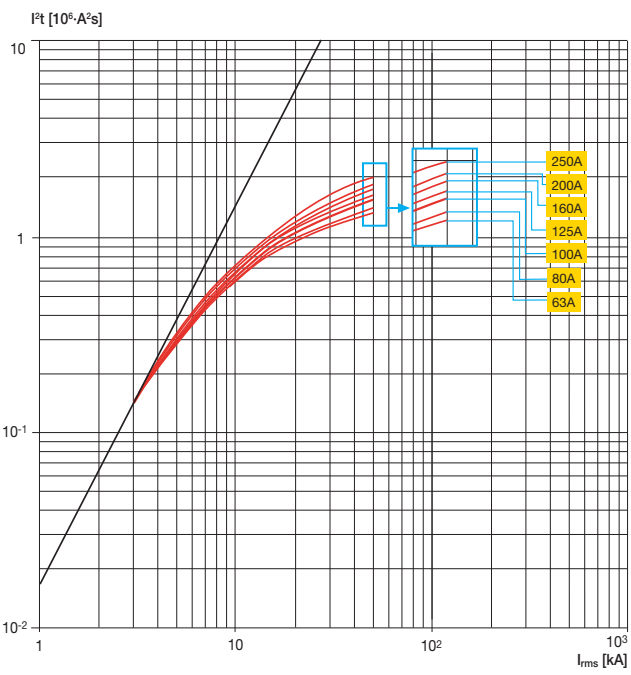

1SDC210E46F0001

T4 250/320

400-440 V

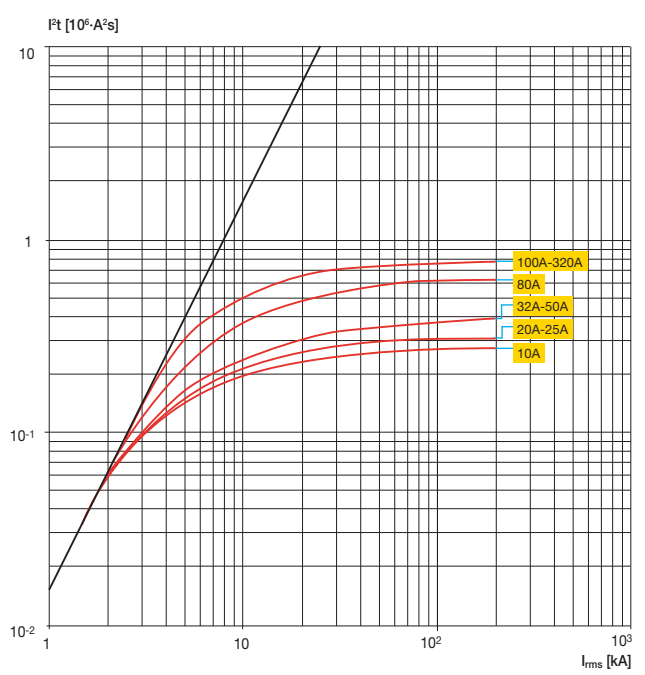

1SDC210E46F0001

Specific let-through energy curves

T5 400/630

400-440 V

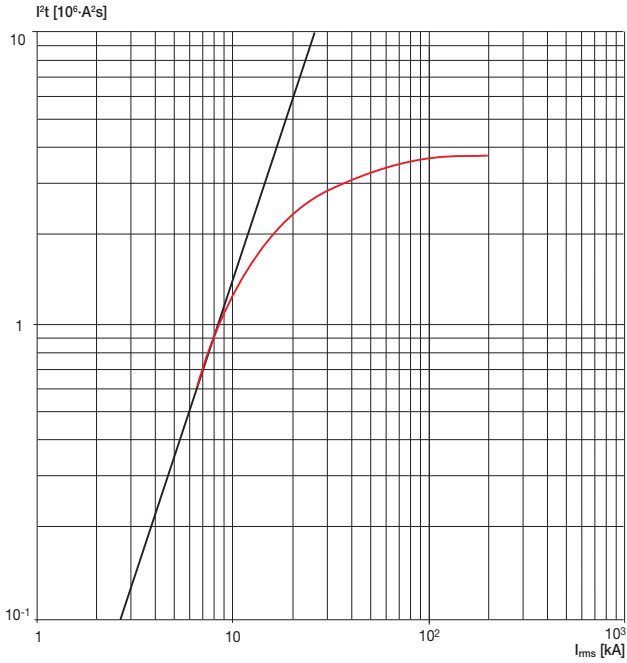

1SDC210647F0001

T6 630/800/1000

400-440 V

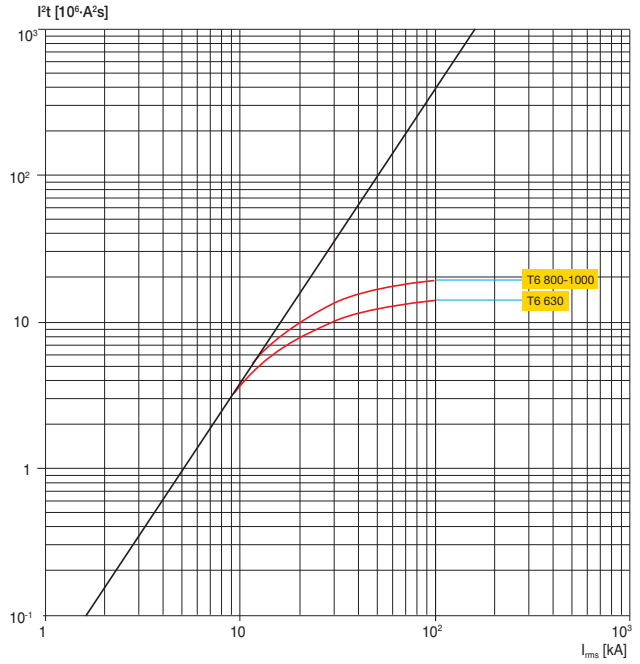

1SDC210648F0001

T7 800/1000/1250/1600

400-440 V

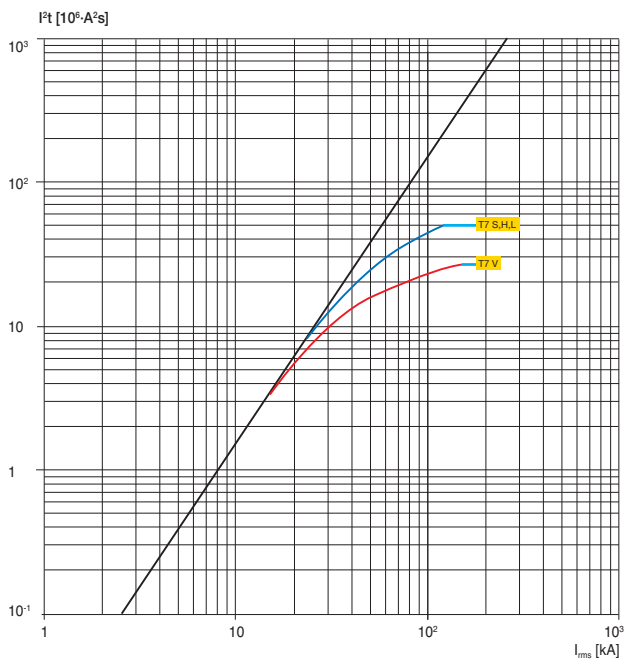

1SDC210641F0001

4

T1 160

500 V

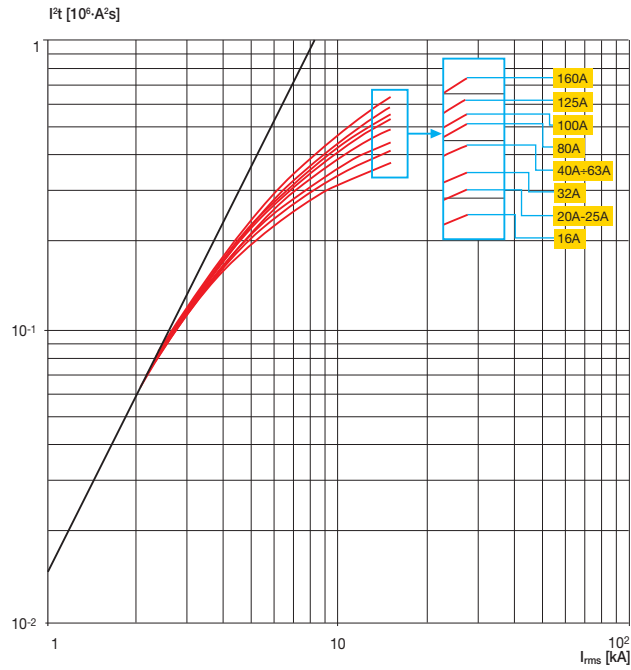

1SDC210E59F0001

T2 160

500 V

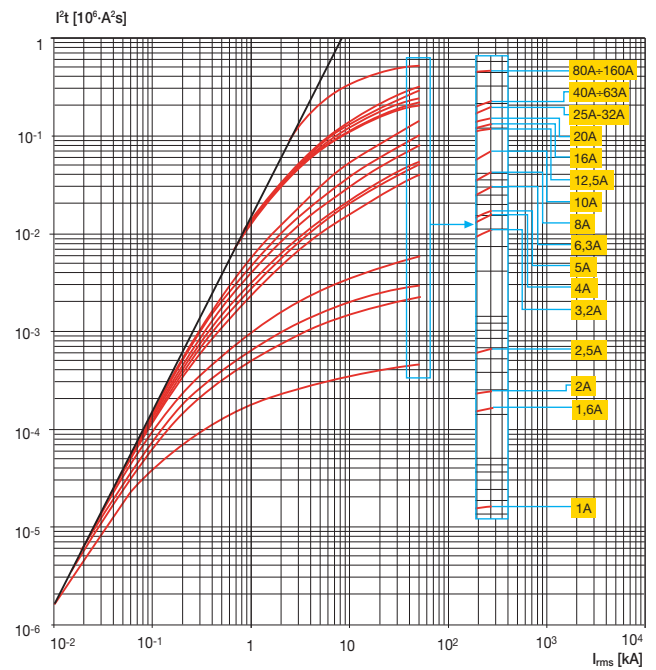

1SDC210E59F0001

T3 250

500 V

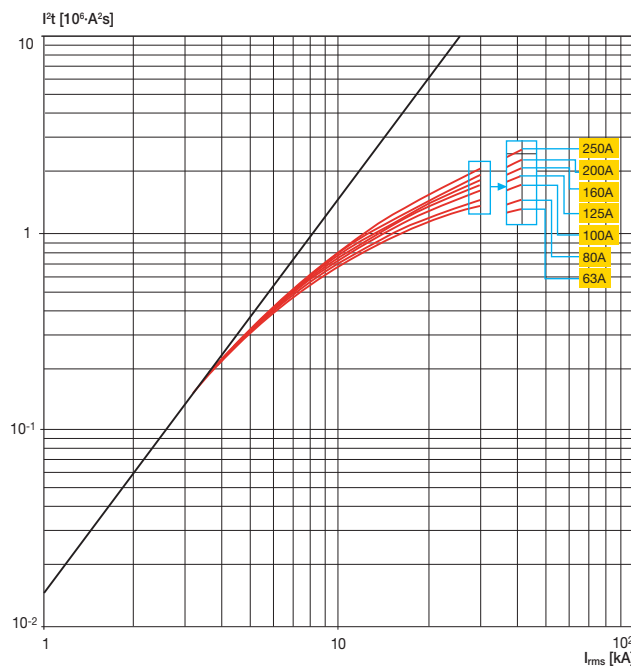

1SDC210E59F0001

T4 250/320

500 V

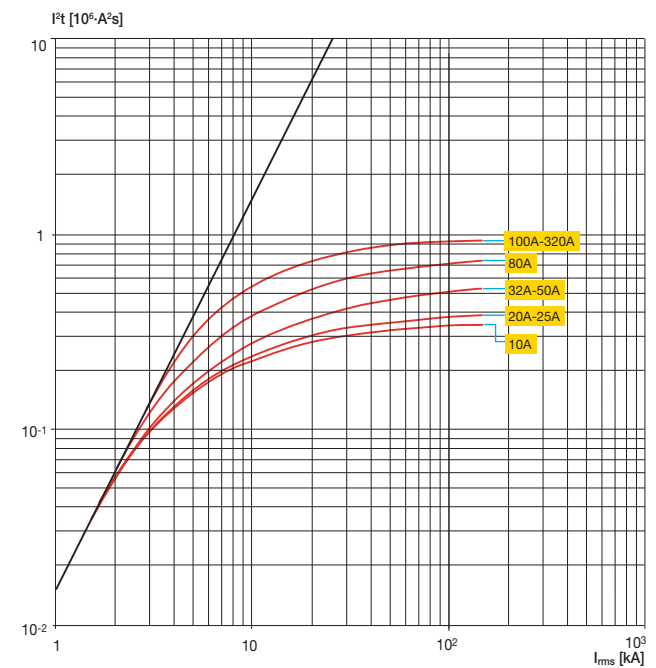

1SDC210E59F0001

Specific let-through energy curves

T5 400/630

500 V

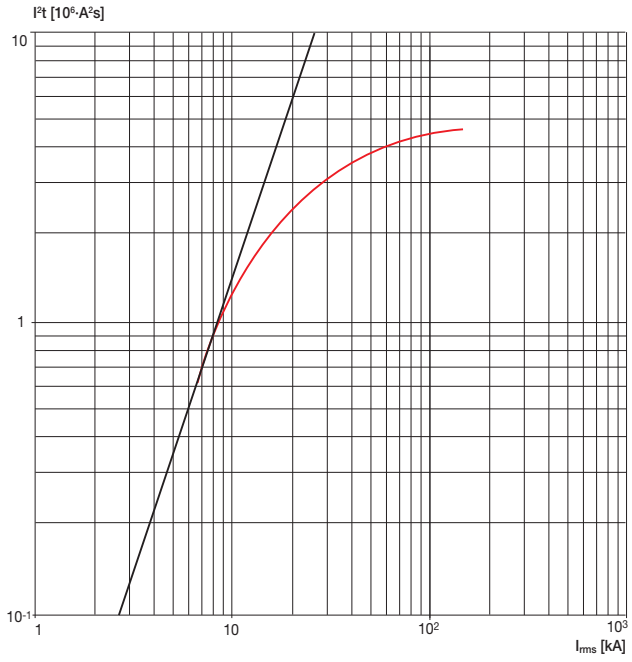

T6 630/800/1000

500 V

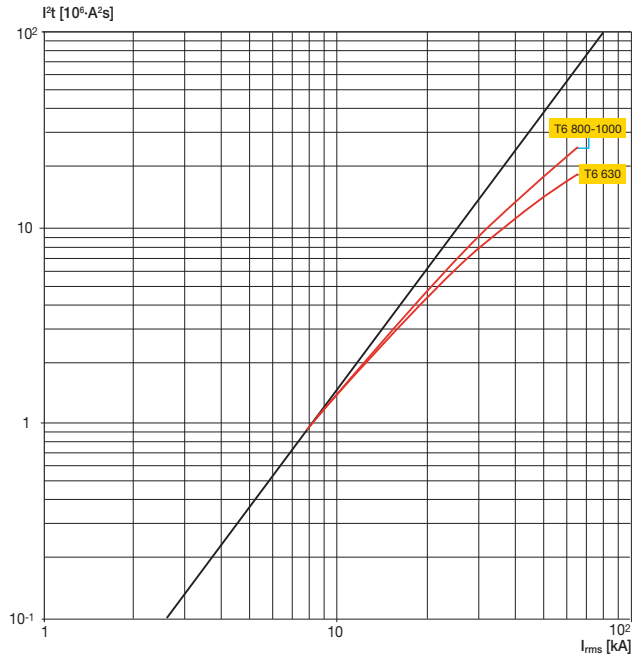

T7 800/1000/1250/1600

500 V

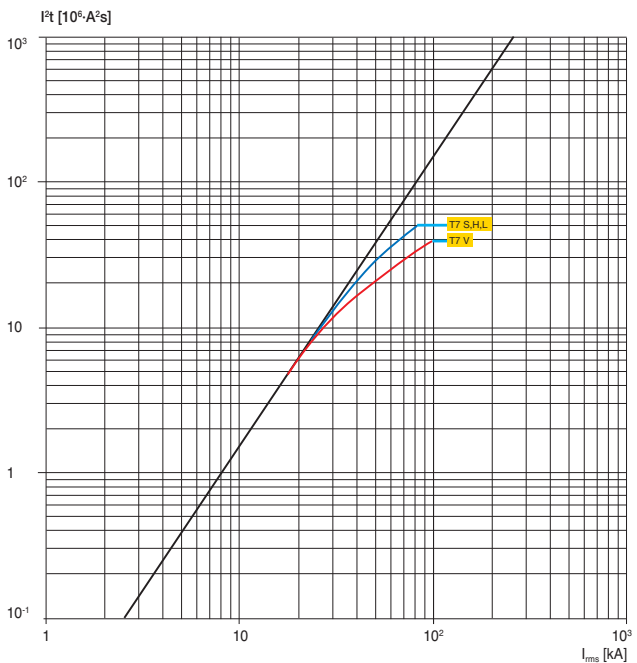

4

T1 160

690 V

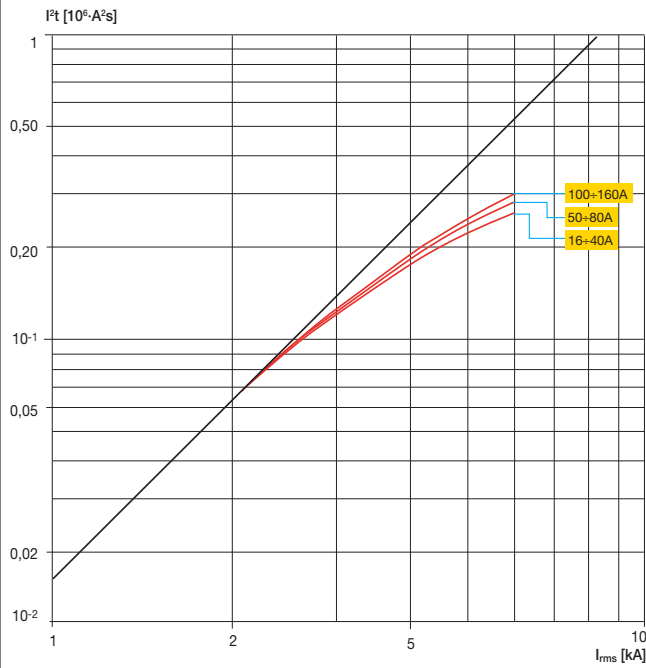

T2 160

690 V

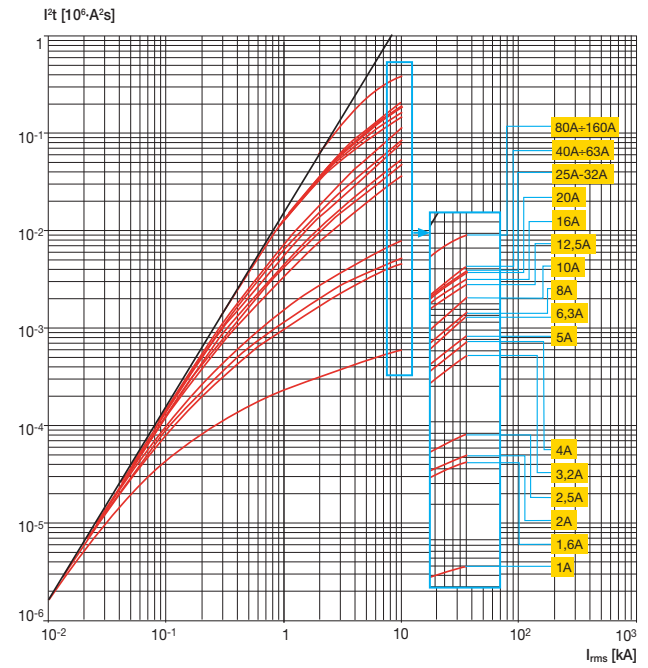

T3 250

690 V

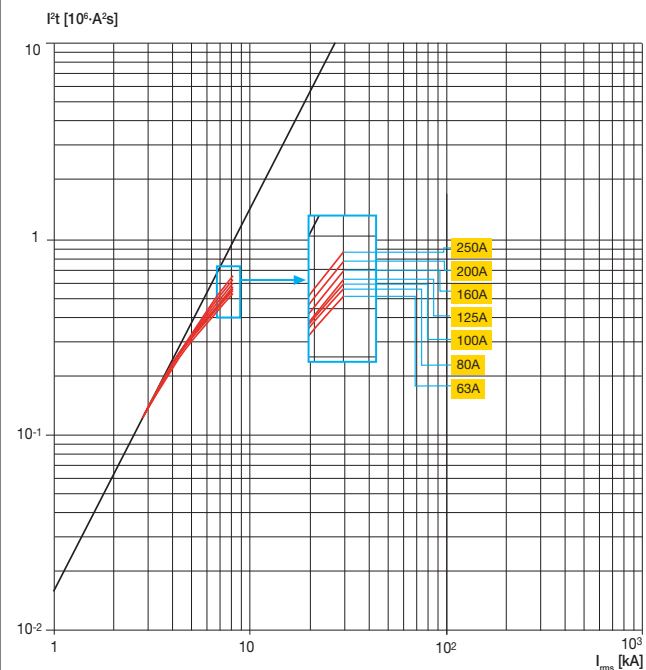

T4 250/320

690 V

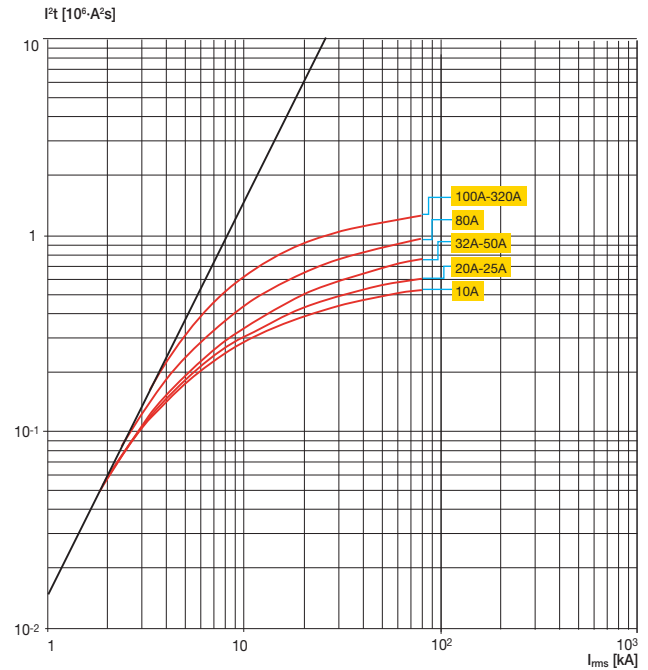

Specific let-through energy curves

T5 400/630

690 V

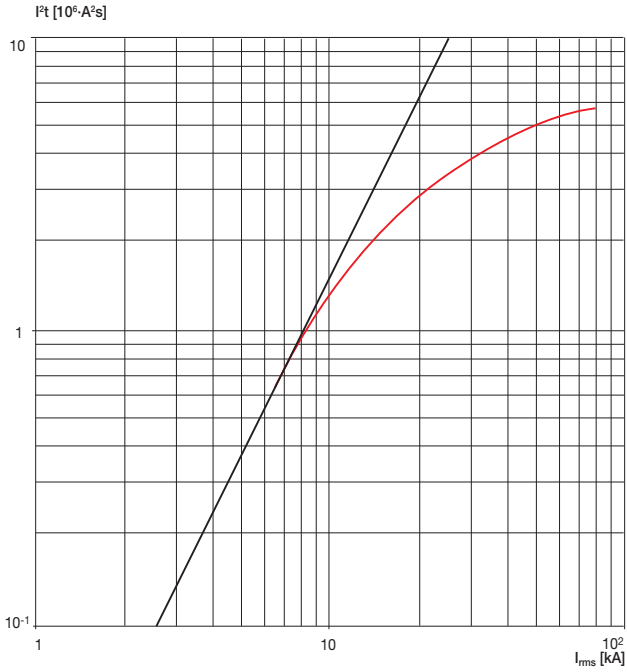

1SDC210E69F0001

T6 630/800/1000

690 V

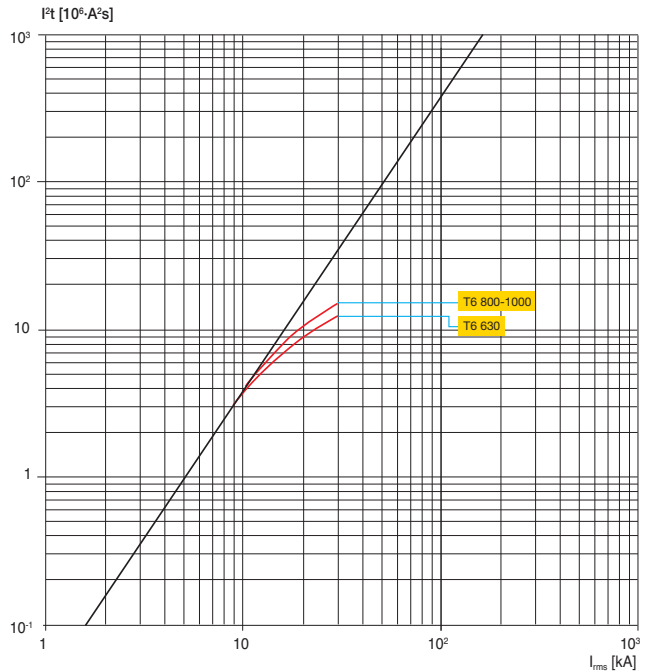

1SDC210E69F0001

T7 800/1000/1250/1600

690 V

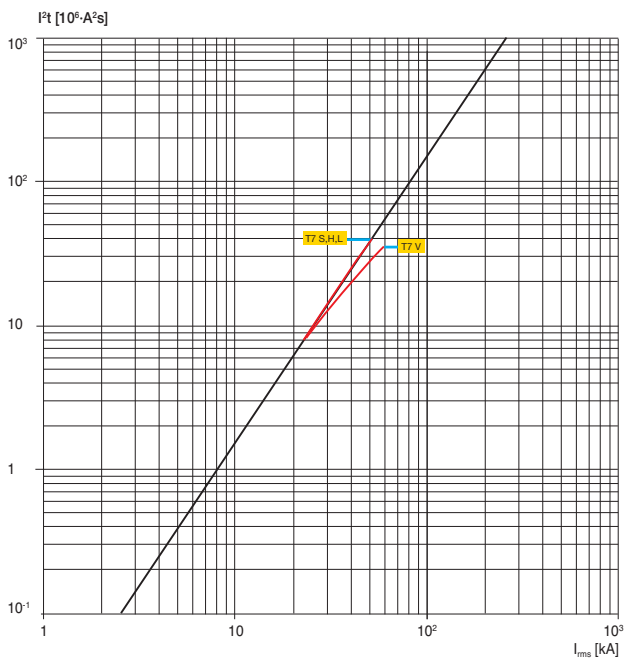

1SDC210F49F0001

4

T4 250

1000 V

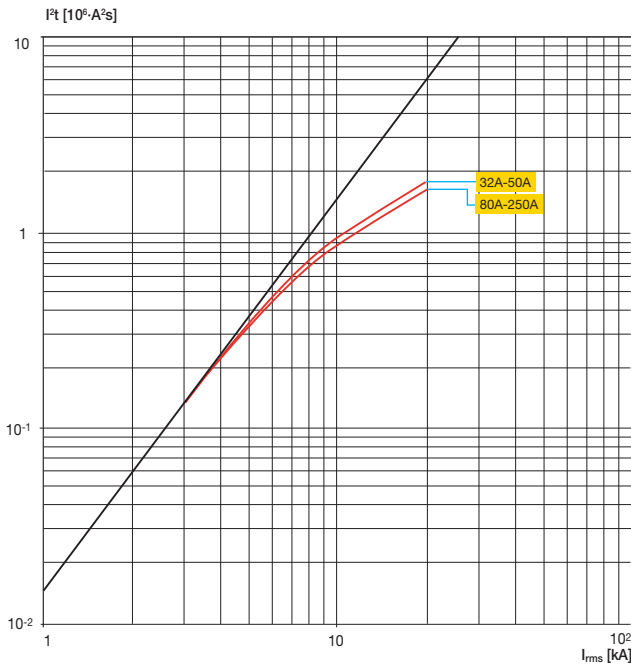

T5 400/630

1000 V

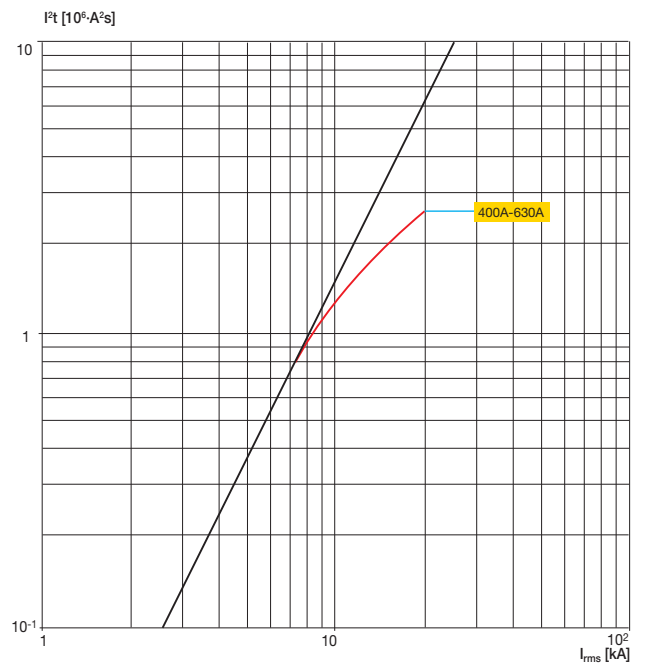

T6

1000 V

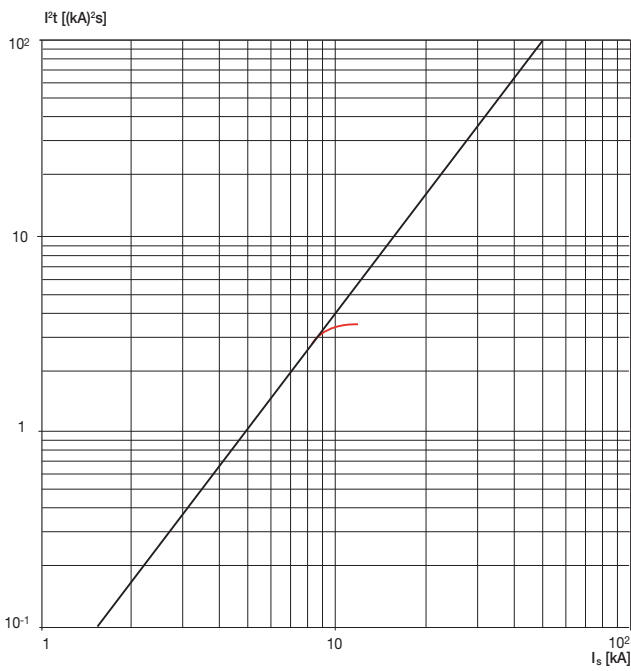

Specific let-through energy curves

T4 250

1150 V

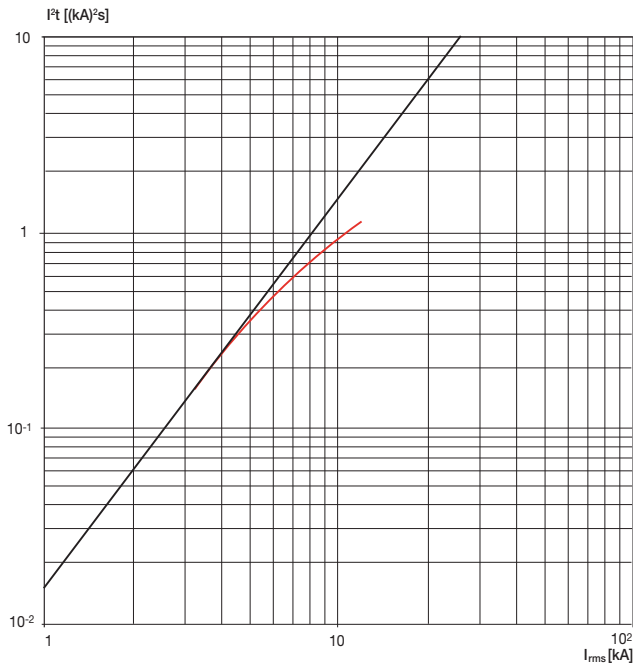

T5 400/630

1150 V

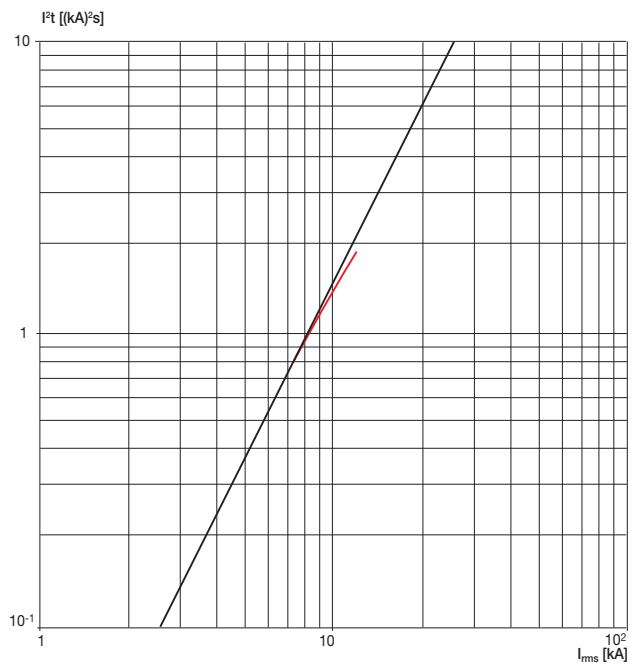

Limitation curves

T1 160

230 V

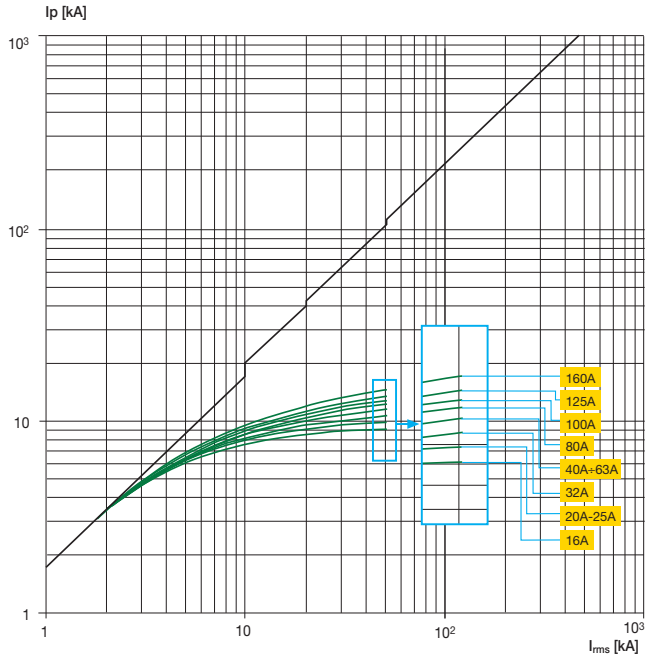

T2 160

230 V

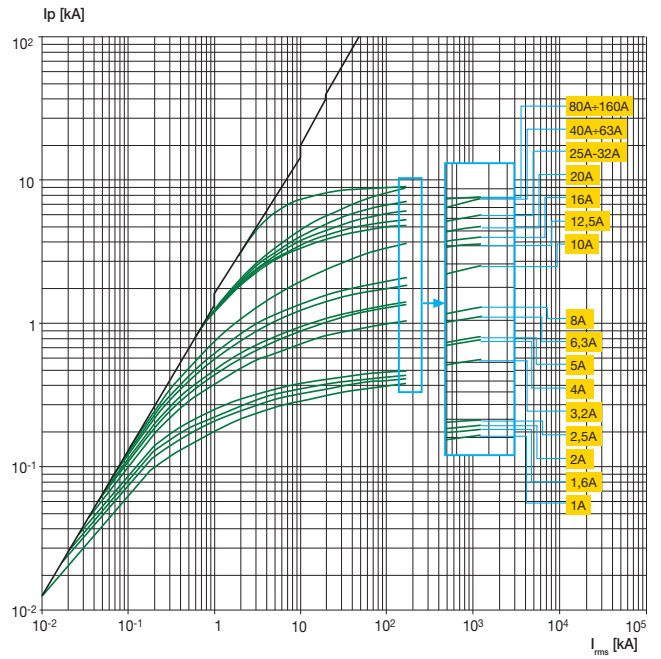

T3 250

230 V

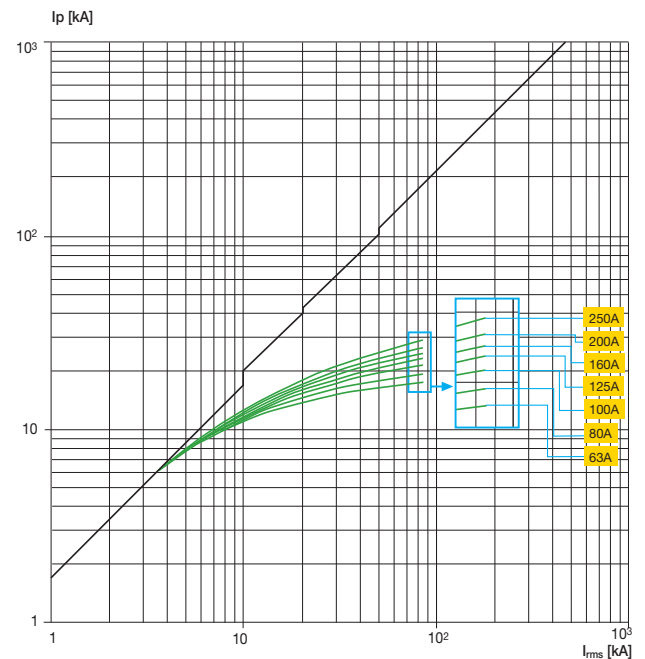

T4 250/320

230 V

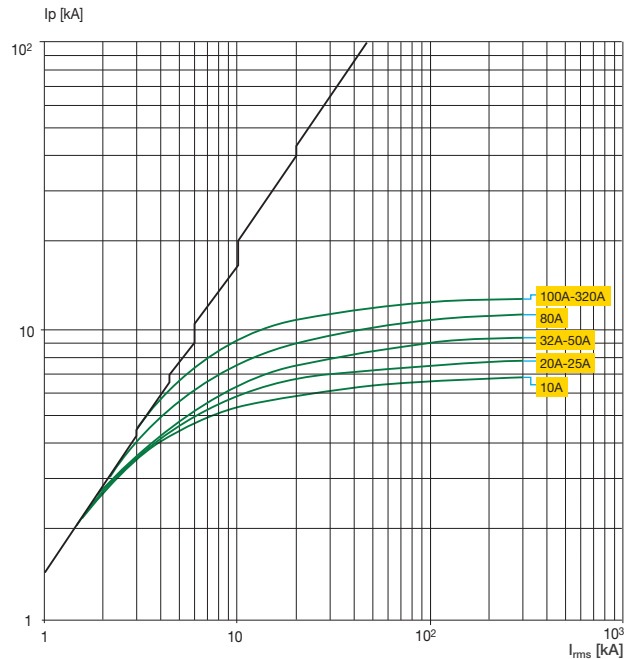

Limitation curves

T5 400/630

230 V

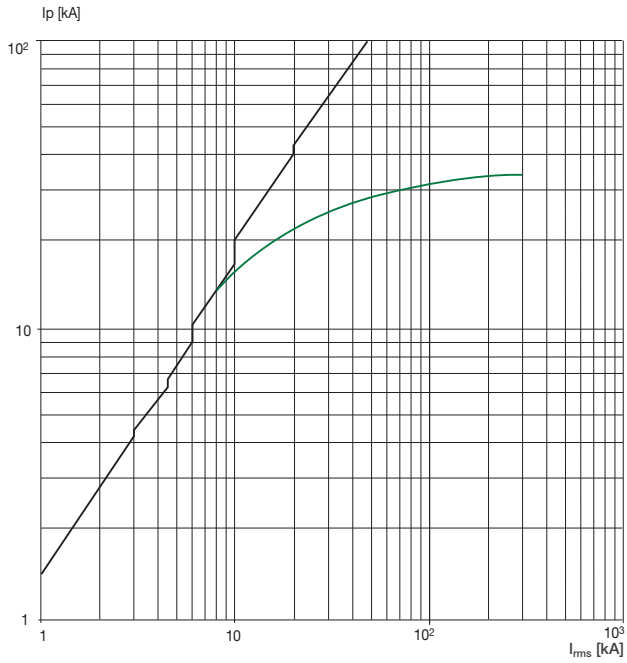

1SDC210E87F0001

T6 630/800/1000

230 V

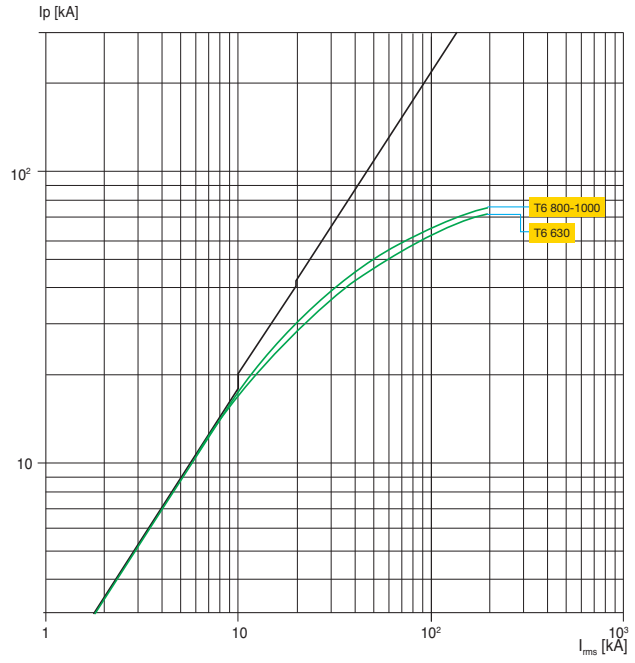

1SDC210E88F0001

T7 800/1000/1250/1600

230 V

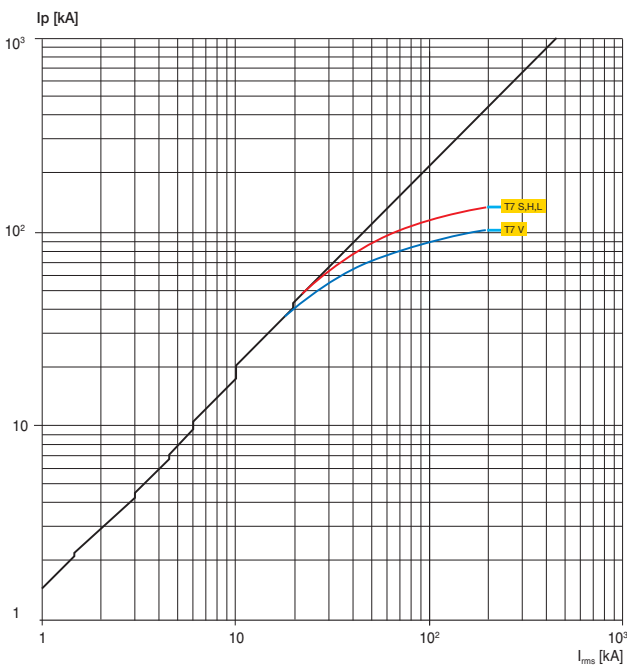

1SDC210F44F0001

4

T1 160

400-440 V

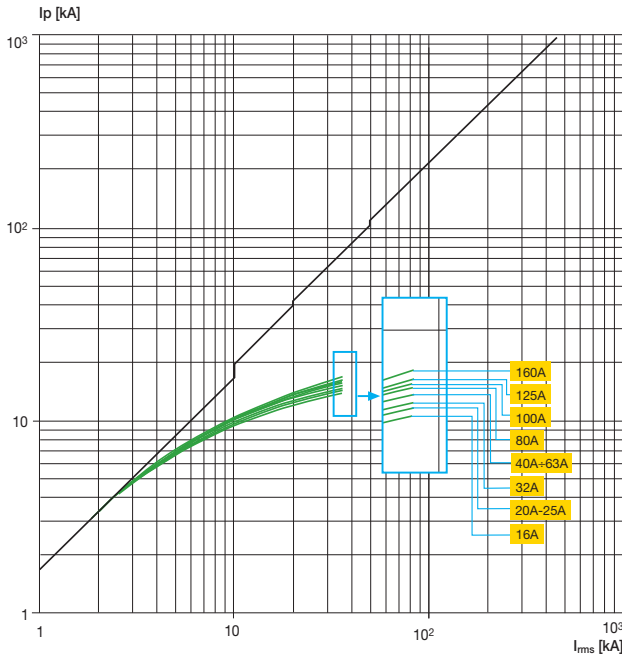

1SDC210E69F0001

T2 160

400-440 V

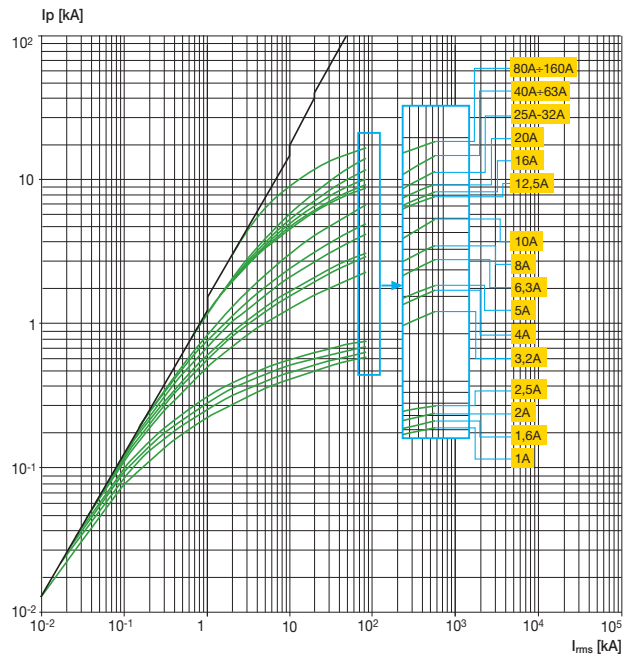

1SDC210E70F0001

T3 250

400-440 V

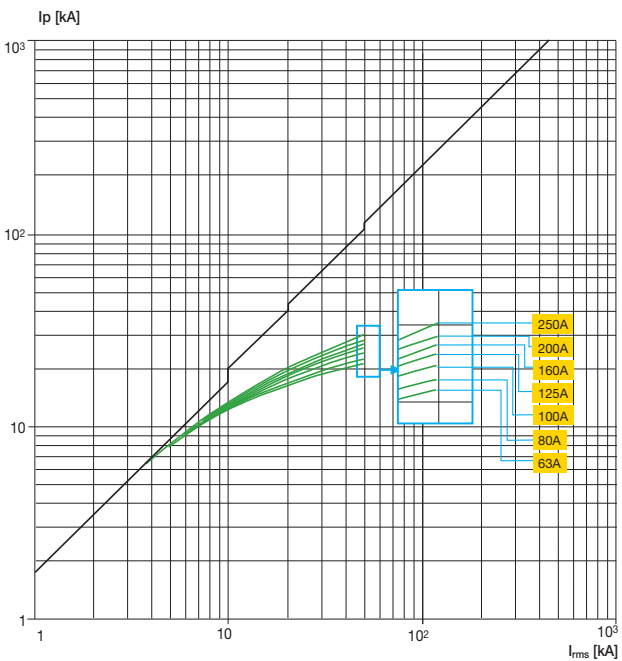

1SDC210E71F0001

T4 250/320

400-440 V

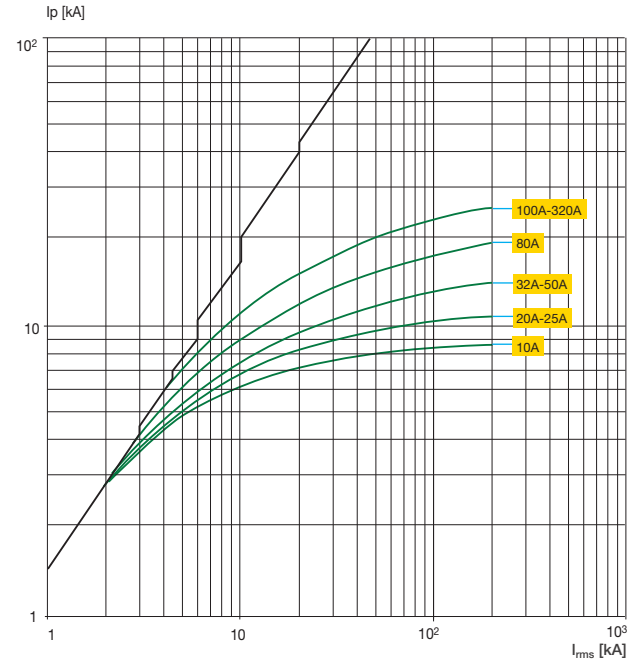

1SDC210E72F0001

Limitation curves

T5 400/630

400-440 V

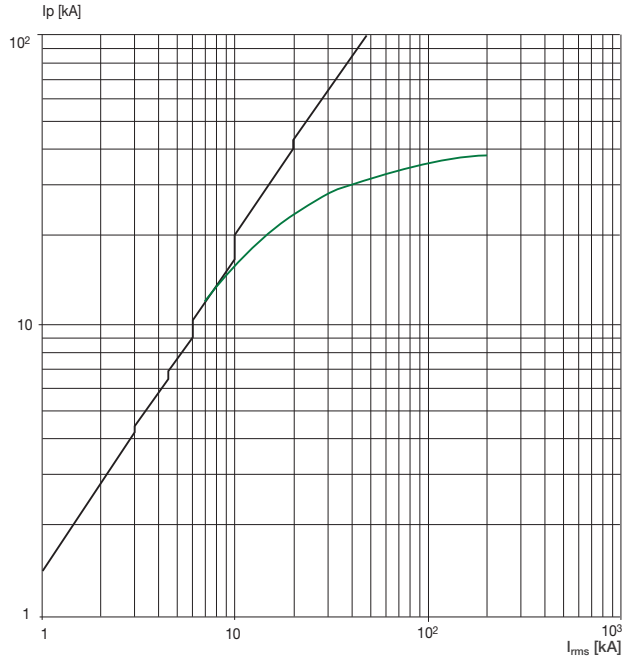

1SDC210E73F0001

T6 630/800/1000

400-440 V

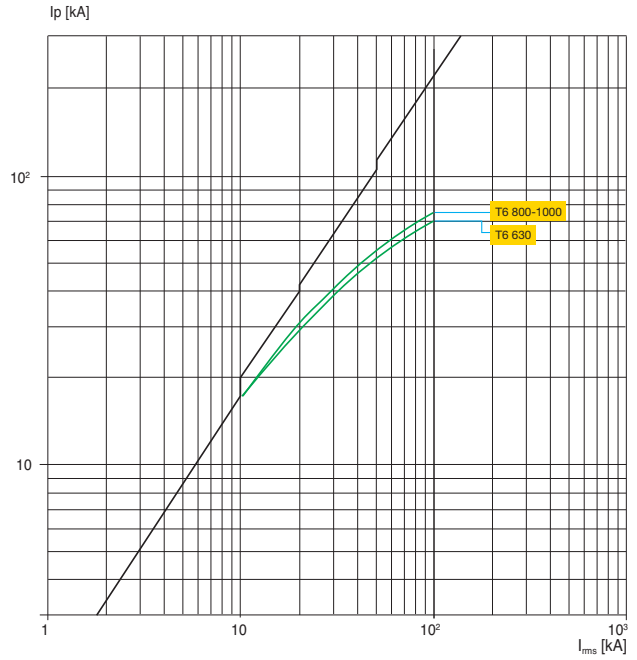

1SDC210E74F0001

T7 800/1000/1250/1600

400-440 V

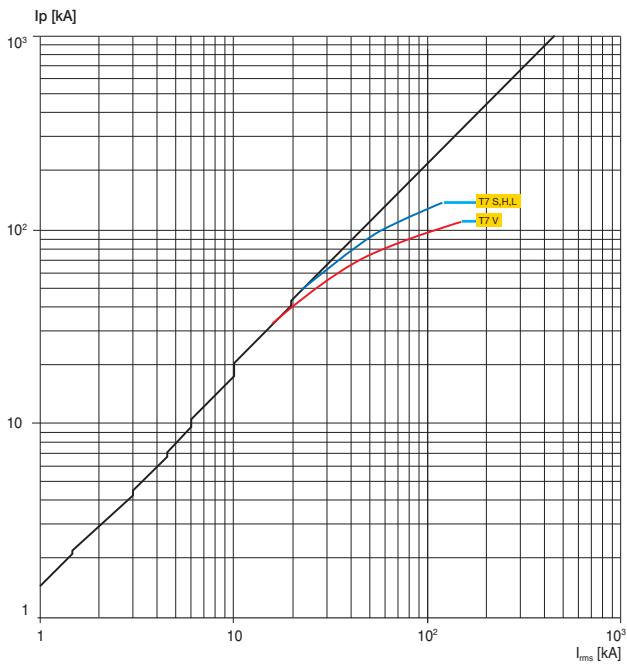

1SDC210F46F0001

4

T1 160

500 V

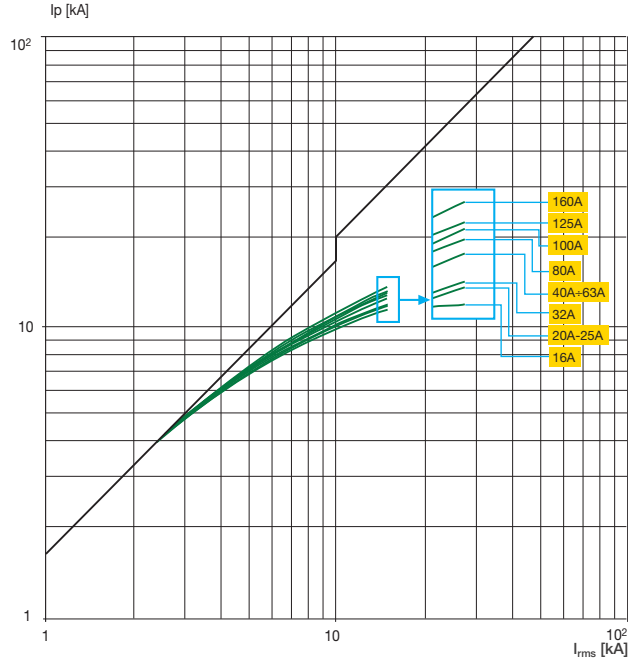

1SDC210E77F0001

T2 160

500 V

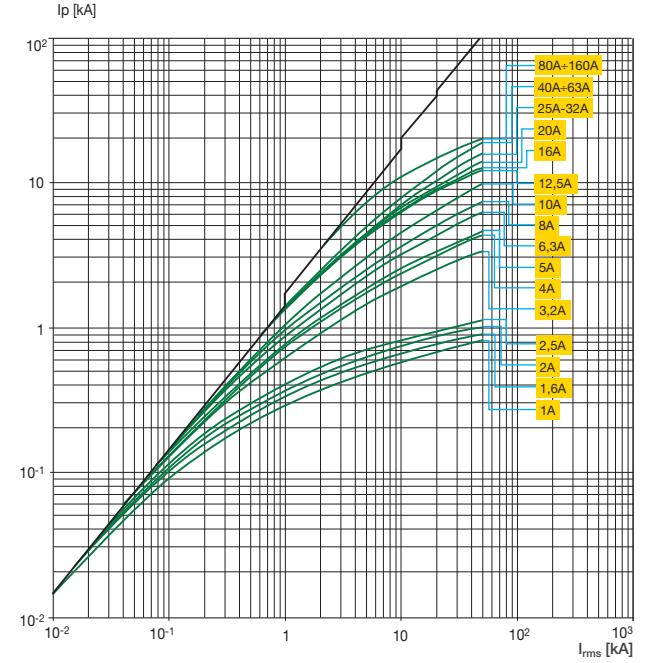

1SDC210E77F0001

T3 250

500 V

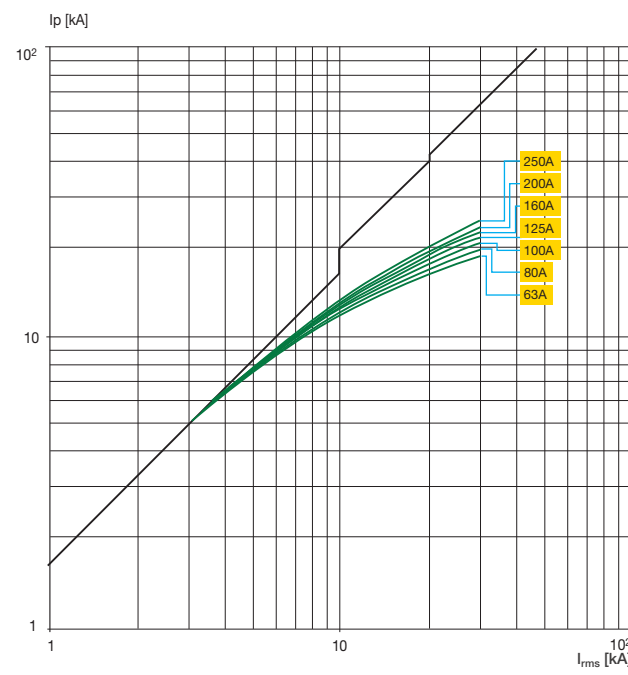

1SDC210E77F0001

T4 250/320

500 V

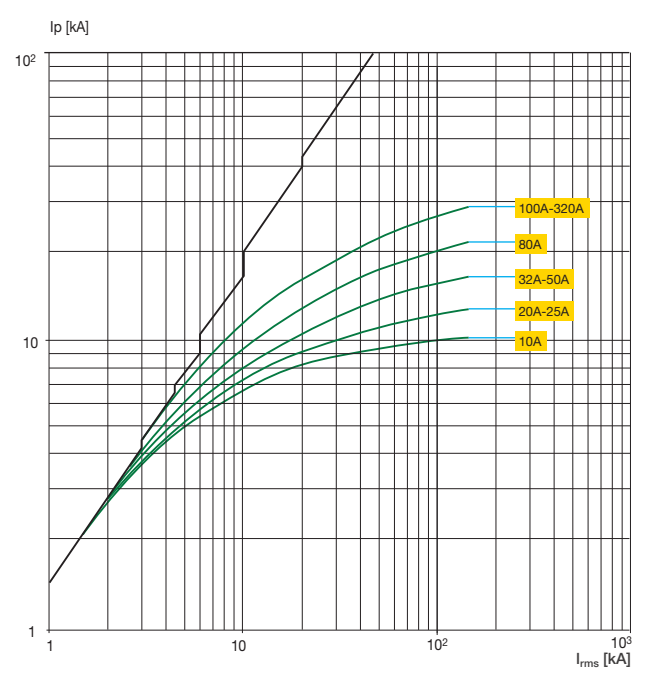

1SDC210E77F0001

Limitation curves

T5 400/630

500 V

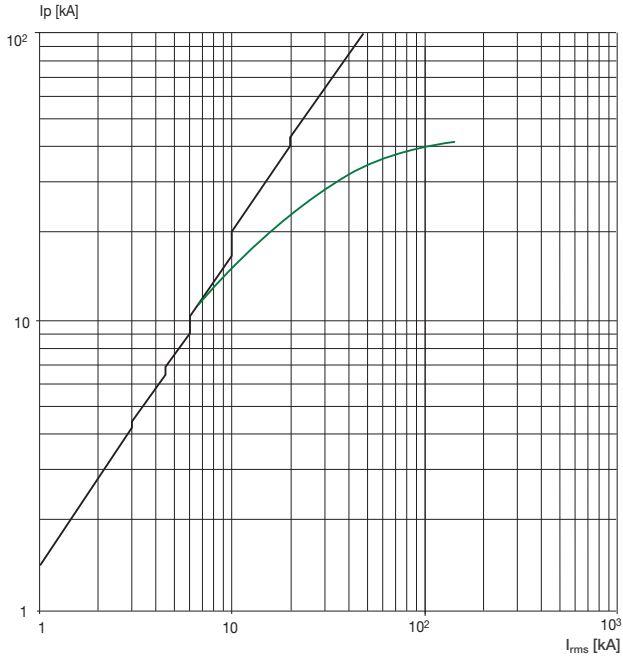

1SDC210E79F0001

T6 630/800/1000

500 V

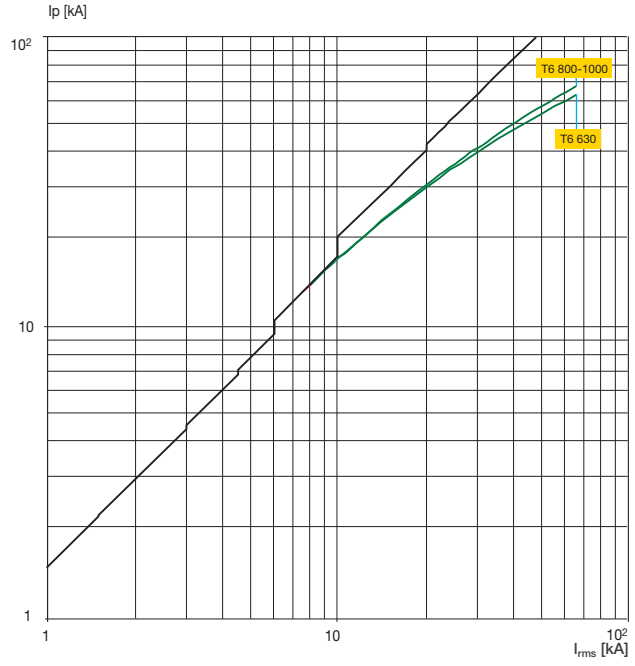

1SDC210E80F0001

T7 800/1000/1250/1600

500 V

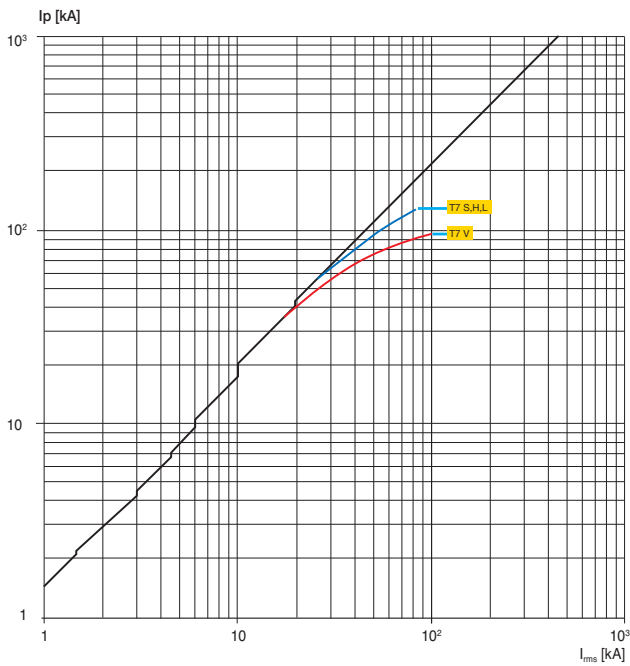

1SDC210E49F0001

4

T1 160

690 V

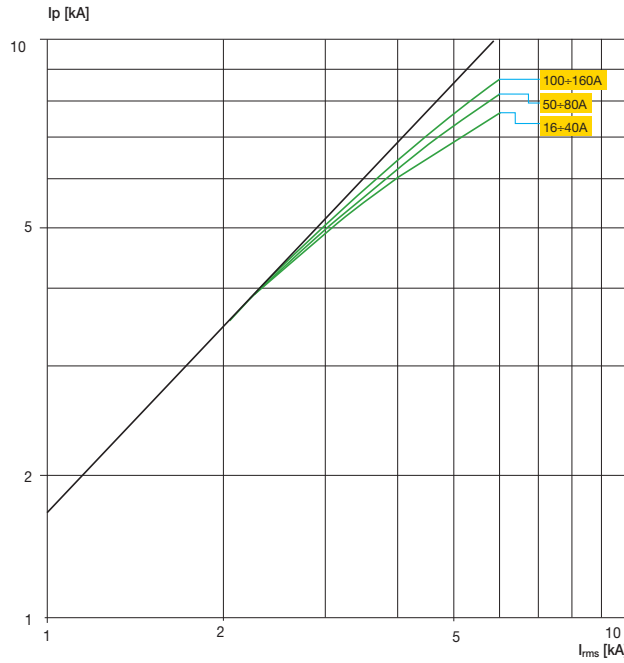

T2 160

690 V

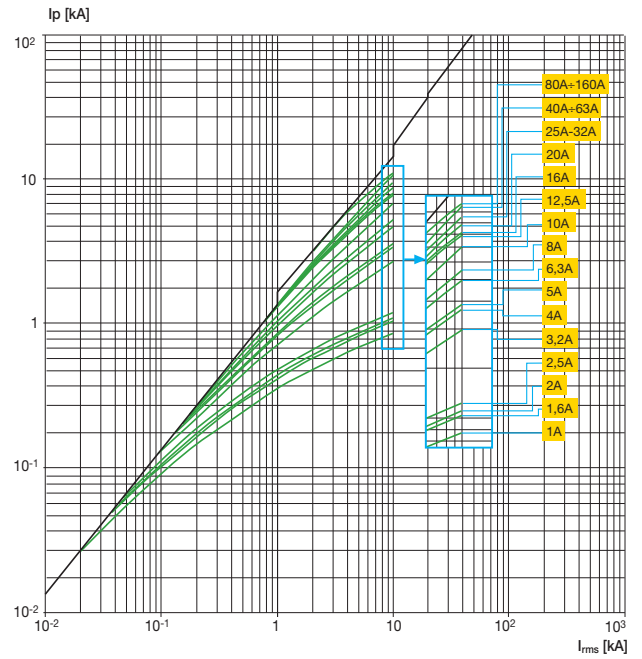

T3 250

690 V

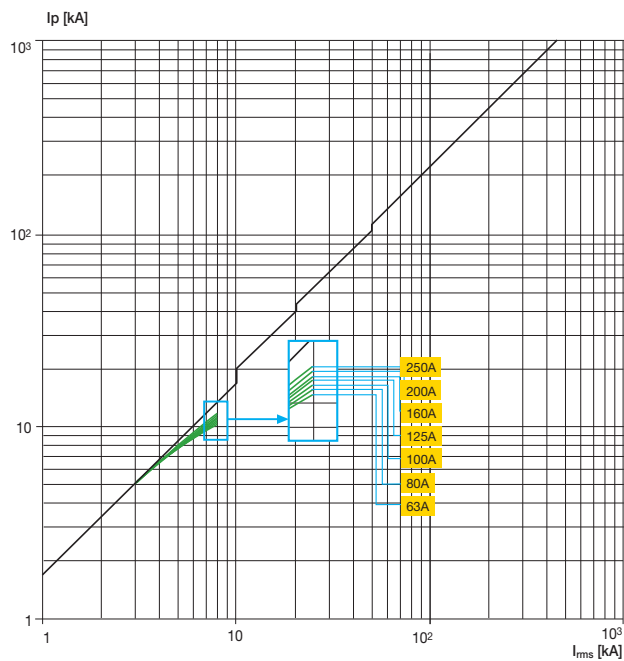

T4 250/320

690 V

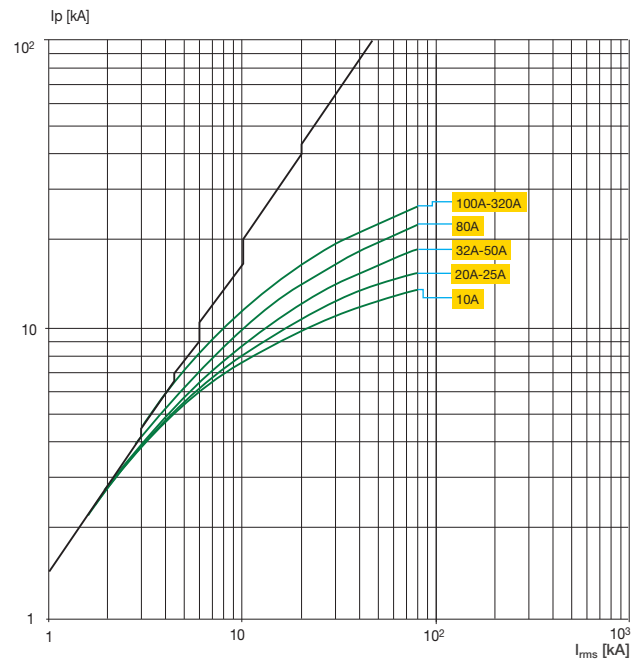

Limitation curves

T5 400/630

690 V

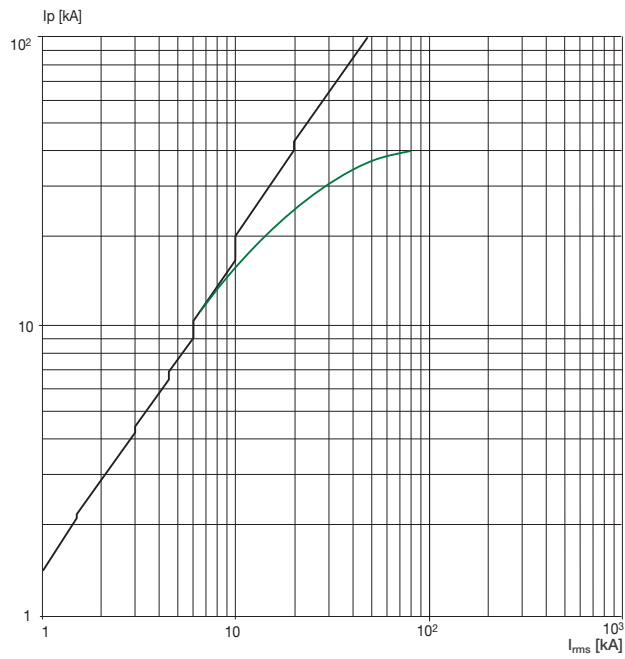

1SDC210E96F0001

T6 630/800/1000

690 V

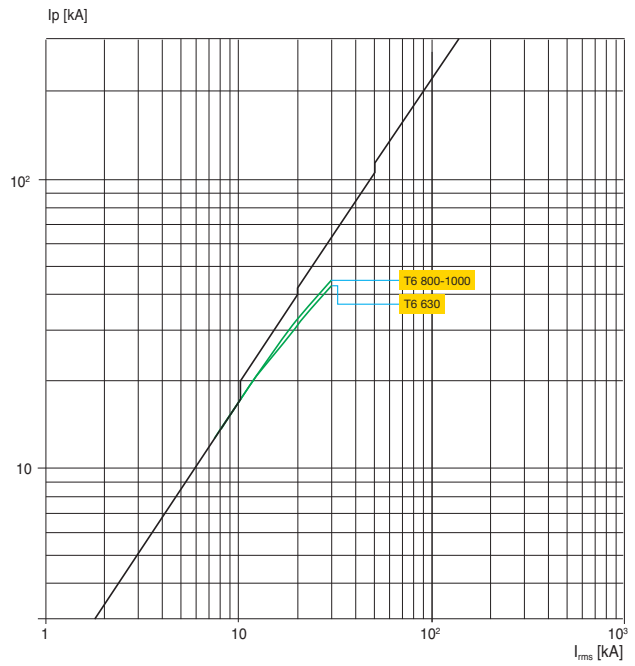

1SDC210E96F0001

T7 800/1000/1250/1600

690 V

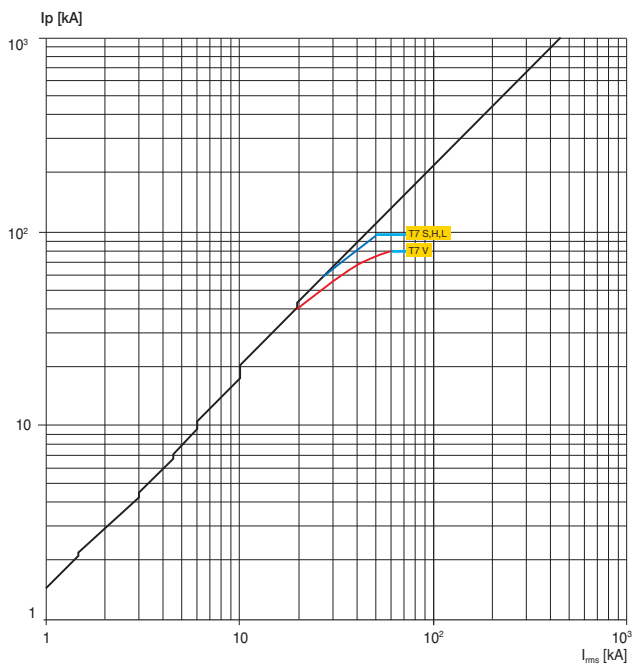

1SDC210F47F0001

4

T4 250

1000 V

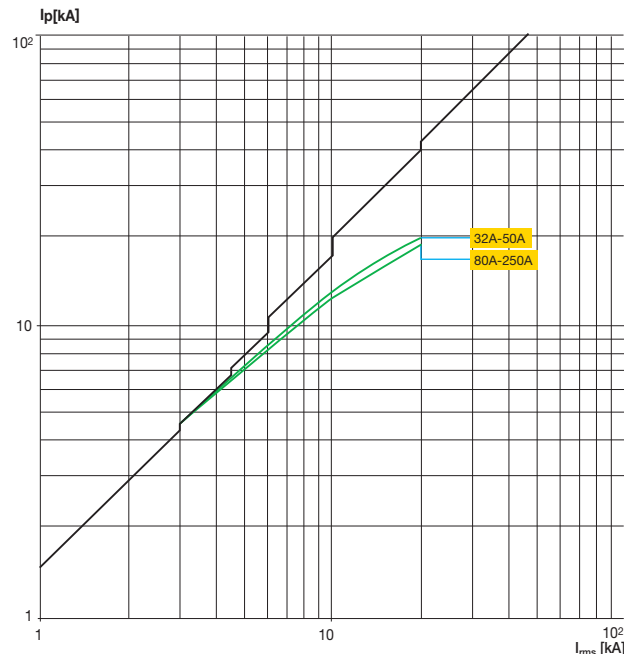

T5 400/630

1000 V

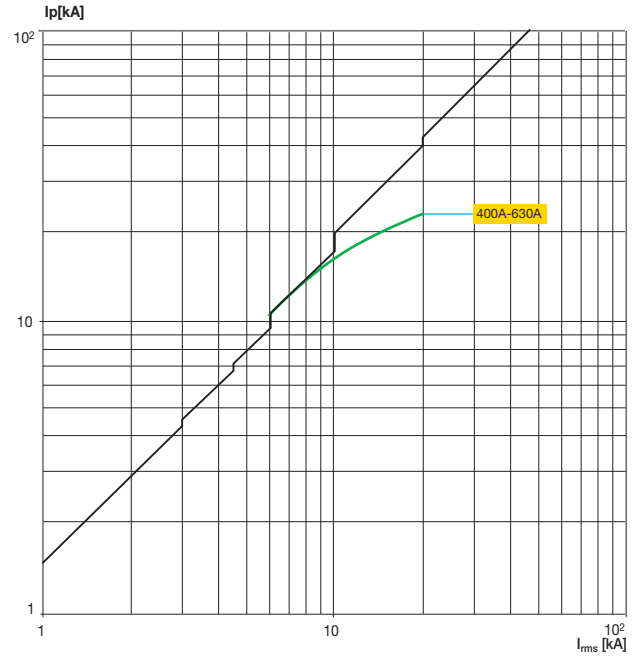

T6

1000 V

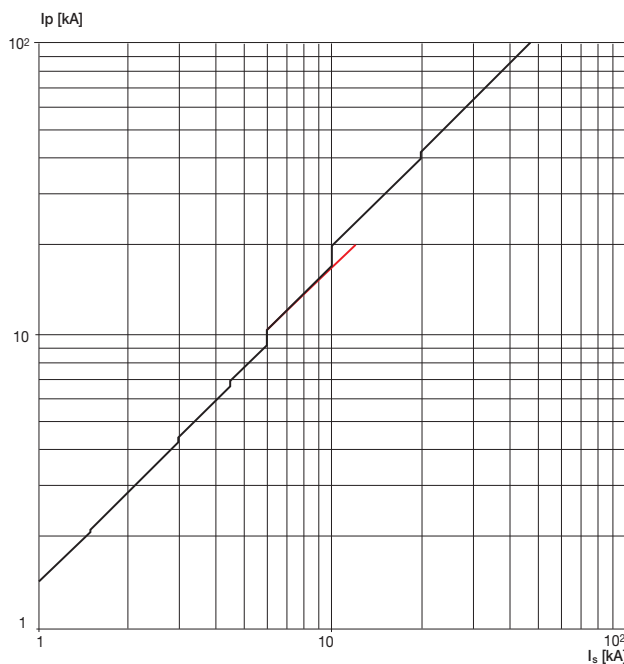

Limitation curves

T4 250

1150 V

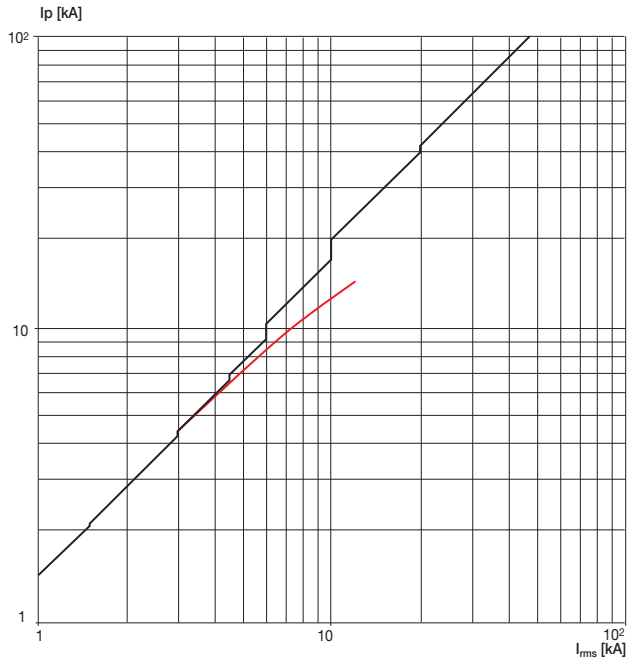

1SDC210F69F0001

T5 400/630

1150 V

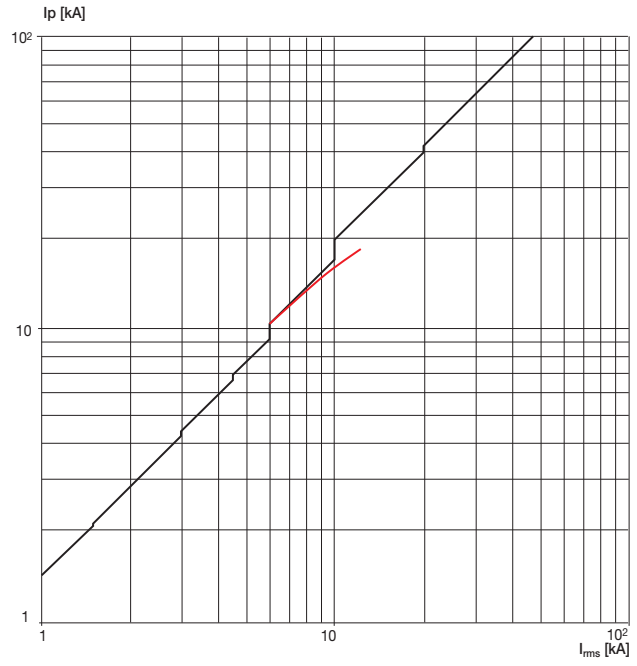

1SDC210F70F0001

Temperature performances

Circuit-breakers with magnetic only or electronic trip units and switch-disconnectors

T1D 160

	up to 40 °C	50 °C	60 °C	70 °C
	I_{max} [A]	I_{max} [A]	I_{max} [A]	I_{max} [A]
FC	160	160	152	136
F	160	160	152	136

FC = Front cable terminals

F = Front flat terminals

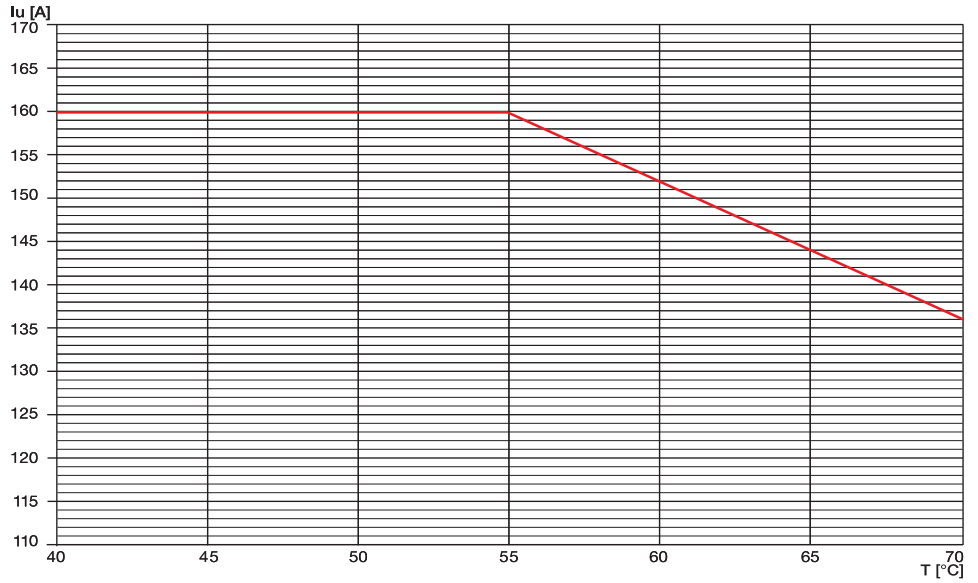

1SDC210E89P001

Temperature performances

Circuit-breakers with magnetic only or electronic trip units and switch-disconnectors

T2 160

	up to 40 °C		50 °C		60 °C		70 °C	
	I _{max} [A]	I _t	I _{max} [A]	I _t	I _{max} [A]	I _t	I _{max} [A]	I _t
F	160	1	153.6	0.96	140.8	0.88	128	0.8
EF	160	1	153.6	0.96	140.8	0.88	128	0.8
ES	160	1	153.6	0.96	140.8	0.88	128	0.8
FC Cu	160	1	153.6	0.96	140.8	0.88	128	0.8
FC CuAl	160	1	153.6	0.96	140.8	0.88	128	0.8
R	160	1	153.6	0.96	140.8	0.88	128	0.8

F = Front flat terminals
 FC Cu = Front terminals for copper cables
 EF = Front extended terminals
 FC CuAl = Front terminals for CuAl cables
 ES = Front extended spread terminals
 R = Rear terminals

Note: in the plug-in version the maximum setting is derated by 10% at 40 °C.

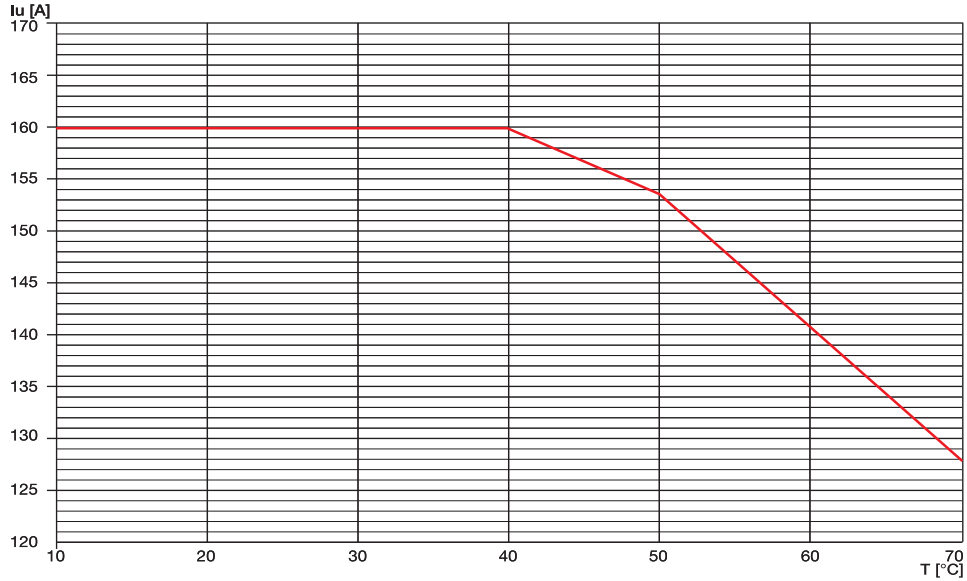

1SDC210E001

T2 160

Plug-in

	up to 40 °C		50 °C		60 °C		70 °C	
	I _{max} [A]	I _t	I _{max} [A]	I _t	I _{max} [A]	I _t	I _{max} [A]	I _t
F	144	0.9	138	0.84	126	0.80	112	0.68
EF	144	0.9	138	0.84	126	0.80	112	0.68
ES	144	0.9	138	0.84	126	0.80	112	0.68
FC Cu	144	0.9	138	0.84	126	0.80	112	0.68
FC CuAl	144	0.9	138	0.84	126	0.80	112	0.68
R	144	0.9	138	0.84	126	0.80	112	0.68

F = Front flat terminals
 FC Cu = Front terminals for copper cables
 EF = Front extended terminals
 FC CuAl = Front terminals for CuAl cables
 ES = Front extended spread terminals
 R = Rear terminals

Note: in the plug-in version the maximum setting is derated by 10% at 40 °C.

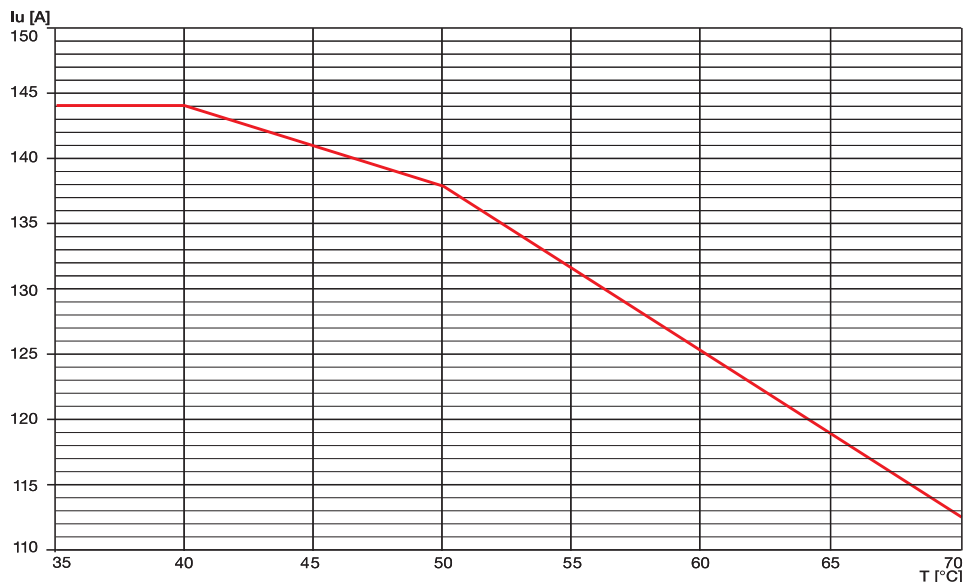

1SDC210R001

T3D 250

	up to 40 °C	50 °C	60 °C	70 °C
F	I_{max} [A]	I_{max} [A]	I_{max} [A]	I_{max} [A]
	250	250	227	204

F = Front flat terminals

Note: in the plug-in version the maximum setting is derated by 10% at 40 °C.

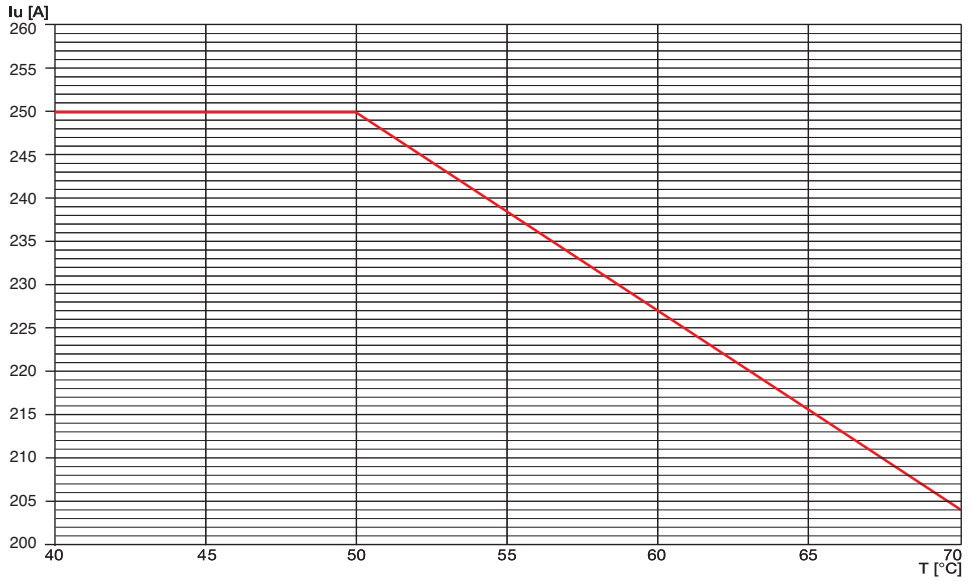

1SDC210015D0205

T3D 250

Plug-in

	up to 40 °C	50 °C	60 °C	70 °C
	I_{max} [A]	I_{max} [A]	I_{max} [A]	I_{max} [A]
F	225	208	190	170
EF	225	208	190	170
ES	225	208	190	170
FC Cu	225	208	190	170
FC CuAl	225	208	190	170

F = Front flat terminals

FC Cu = Front terminals for copper cables

EF = Front extended terminals

FC CuAl = Front terminals for CuAl cables

ES = Front extended spread terminals

Note: in the plug-in version the maximum setting is derated by 10% at 40 °C.

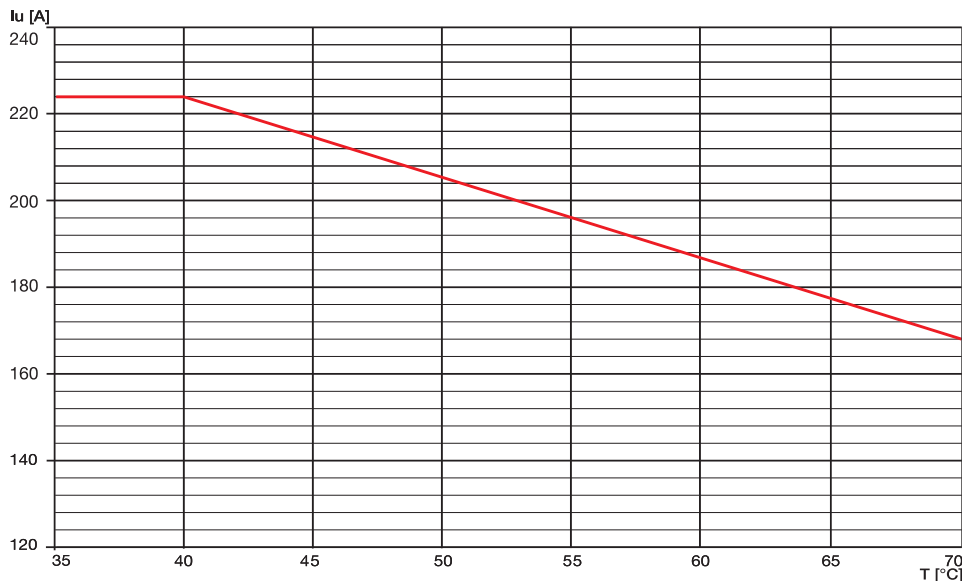

1SDC210015D0205

Temperature performances

Circuit-breakers with magnetic only or electronic trip units and switch-disconnectors

T4 250 and T4D 250

Fixed

	up to 40 °C		50 °C		60 °C		70 °C	
	I _{max} [A]	I ₁	I _{max} [A]	I ₁	I _{max} [A]	I ₁	I _{max} [A]	I ₁
FC	250	1	250	1	250	1	220	0.88
F	250	1	250	1	250	1	220	0.88
R (HR)	250	1	250	1	250	1	220	0.88
R (VR)	250	1	250	1	250	1	230	0.92

FC = Front cables terminals
R (VR) = Rear terminals (vertical)

F = Front flat terminals
R (HR) = Rear terminals (horizontal)

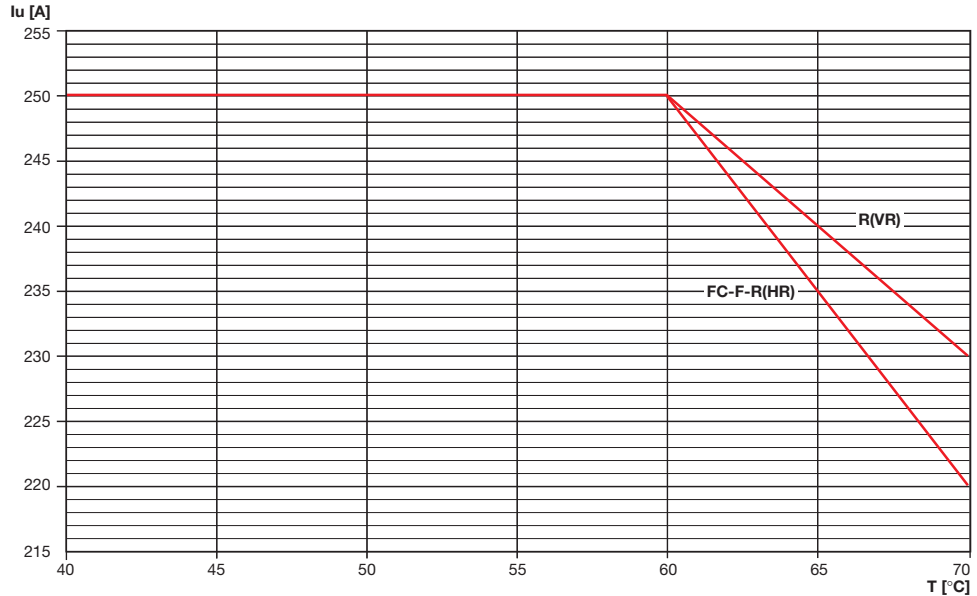

1SDC210E94P0001

T4 250 and T4D 250

Plug-in / Withdrawable

	up to 40 °C		50 °C		60 °C		70 °C	
	I _{max} [A]	I ₁	I _{max} [A]	I ₁	I _{max} [A]	I ₁	I _{max} [A]	I ₁
FC	250	1	250	1	230	0.92	210	0.84
F	250	1	250	1	230	0.92	210	0.84
HR	250	1	250	1	230	0.92	210	0.84
VR	250	1	250	1	240	0.96	220	0.88

FC = Front cables terminals
VR = Rear flat vertical terminals

F = Front flat terminals
HR = Rear flat horizontal terminals

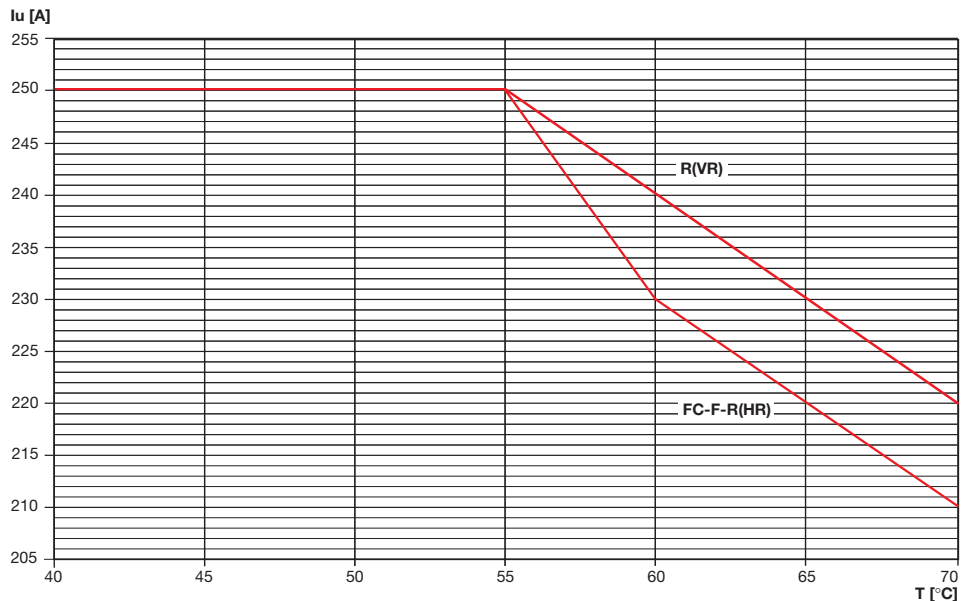

1SDC210E94P0001

T4 320 and T4D 320

Fixed

	up to 40 °C		50 °C		60 °C		70 °C	
	I_{max} [A]	I_1	I_{max} [A]	I_1	I_{max} [A]	I_1	I_{max} [A]	I_1
FC	320	1	294	0.92	269	0.84	243	0.76
F	320	1	294	0.96	269	0.84	243	0.76
R (HR)	320	1	294	0.92	269	0.84	243	0.76
R (VR)	320	1	307	0.96	281	0.88	256	0.80

FC = Front cables terminals
R (VR) = Rear terminals (vertical)

F = Front flat terminals

R (HR) = Rear terminals (horizontal)

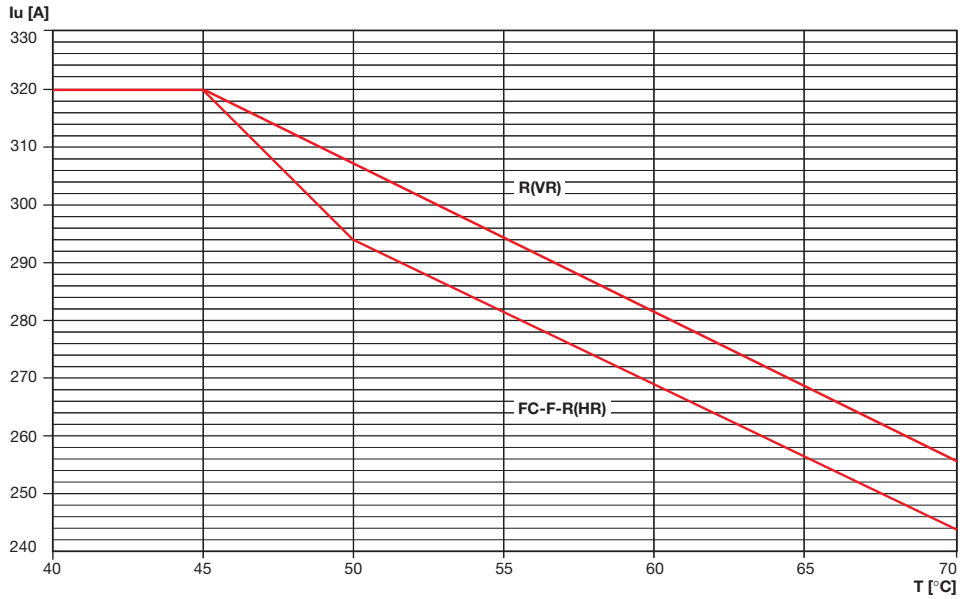

T4 320 and T4D 320

Plug-in / Withdrawable

	up to 40 °C		50 °C		60 °C		70 °C	
	I_{max} [A]	I_1	I_{max} [A]	I_1	I_{max} [A]	I_1	I_{max} [A]	I_1
FC	320	1	294	0.92	268	0.84	242	0.76
F	320	1	294	0.92	268	0.84	242	0.76
HR	320	1	294	0.92	268	0.84	242	0.76
VR	320	1	307	0.96	282	0.88	256	0.80

FC = Front cables terminals
VR = Rear flat vertical terminals

F = Front flat terminals

HR = Rear flat horizontal terminals

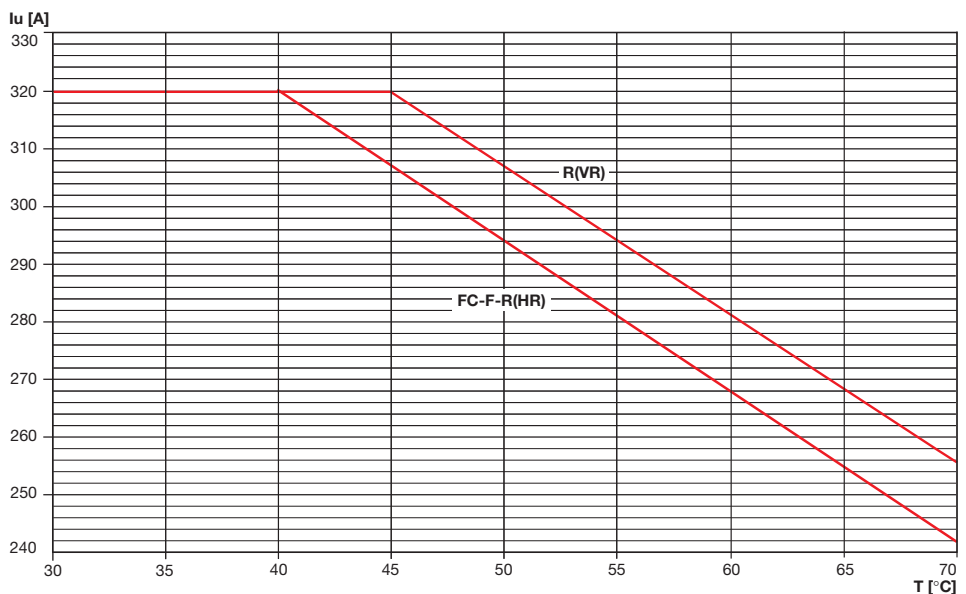

1SDC210694F001

1SDC210694F001

Temperature performances

Circuit-breakers with magnetic only or electronic trip units and switch-disconnectors

T4 320 and T4D 320 Plug-in / Withdrawable with RC222

	up to 40 °C		50 °C		60 °C		70 °C	
	I _{max} [A]	I _n	I _{max} [A]	I _n	I _{max} [A]	I _n	I _{max} [A]	I _n
FC	282	0.88	262	0.82	230	0.72	212	0.66
F	282	0.88	262	0.82	230	0.72	212	0.66
HR	282	0.88	262	0.82	230	0.72	212	0.66
VR	282	0.88	269	0.82	250	0.78	224	0.70

FC = Front cables terminals
VR = Rear flat vertical terminals

F = Front flat terminals
HR = Rear flat horizontal terminals

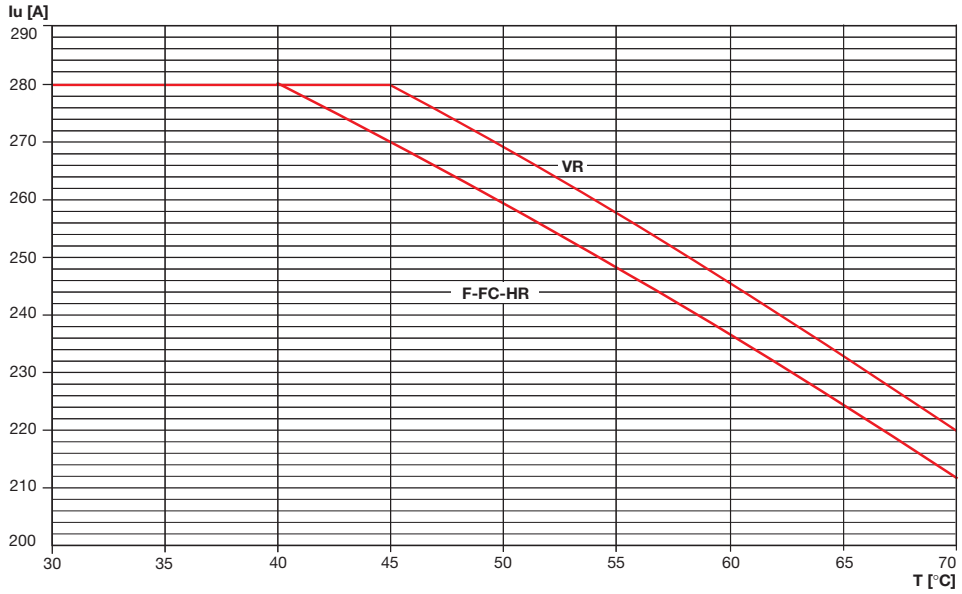

1SDC210R6F0001

T5 400 and T5D 400

Fixed

	up to 40 °C		50 °C		60 °C		70 °C	
	I_{max} [A]	I_1	I_{max} [A]	I_1	I_{max} [A]	I_1	I_{max} [A]	I_1
FC	400	1	400	1	400	1	352	0.88
F	400	1	400	1	400	1	352	0.88
R (HR)	400	1	400	1	400	1	352	0.88
R (VR)	400	1	400	1	400	1	368	0.92

FC = Front cables terminals
R (VR) = Rear terminals (vertical)

F = Front flat terminals

R (HR) = Rear terminals (horizontal)

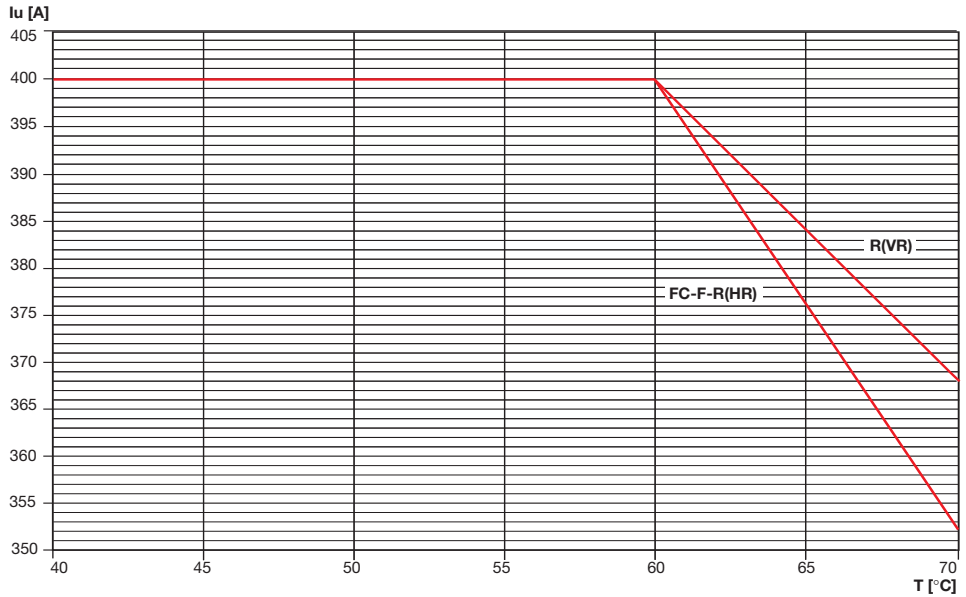

T5 400 and T5D 400

Plug-in / Withdrawable

	up to 40 °C		50 °C		60 °C		70 °C	
	I_{max} [A]	I_1	I_{max} [A]	I_1	I_{max} [A]	I_1	I_{max} [A]	I_1
FC	400	1	400	1	368	0.92	336	0.84
F	400	1	400	1	368	0.92	336	0.84
HR	400	1	400	1	368	0.92	336	0.84
VR	400	1	400	1	382	0.96	350	0.88

FC = Front cables terminals
VR = Rear flat vertical terminals

F = Front flat terminals

HR = Rear flat horizontal terminals

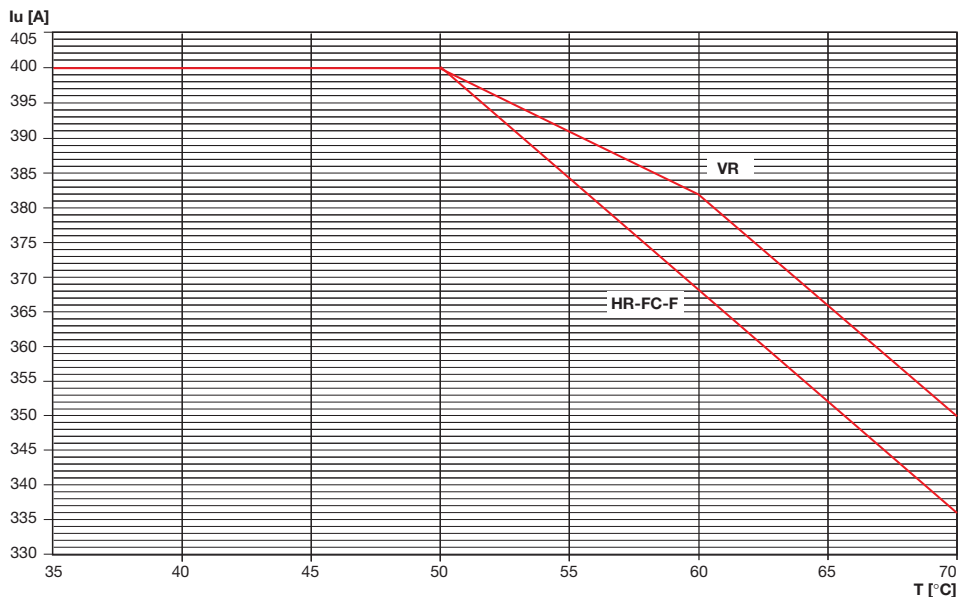

1SDC210594F001

1SDC210597F001

Temperature performances

Circuit-breakers with magnetic only or electronic trip units and switch-disconnectors

T5 630 and T5D 630

Fixed

	up to 40 °C		50 °C		60 °C		70 °C	
	I _{max} [A]	I _t	I _{max} [A]	I _t	I _{max} [A]	I _t	I _{max} [A]	I _t
FC	630	1	580	0.92	529	0.84	479	0.76
F	630	1	580	0.92	529	0.84	479	0.76
R (HR)	630	1	580	0.92	529	0.84	479	0.76
R (VR)	630	1	605	0.96	554	0.88	504	0.80

FC = Front cables terminals
R (VR) = Rear terminals (vertical)
F = Front flat terminals
R (HR) = Rear terminals (horizontal)

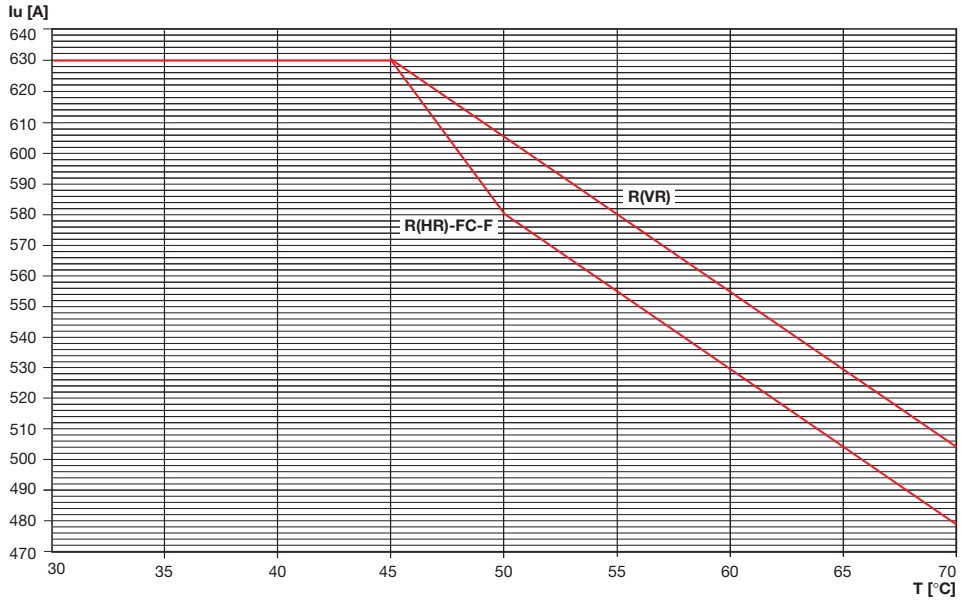

1SDC210699F001

T5 630 and T5D 630

Plug-in / Withdrawable

	up to 40 °C		50 °C		60 °C		70 °C	
	I _{max} [A]	I _t	I _{max} [A]	I _t	I _{max} [A]	I _t	I _{max} [A]	I _t
EF	567	0.9	502	0.80	458	0.72	409	0.64
HR	567	0.9	502	0.80	458	0.72	409	0.64
VR	567	0.9	526	0.82	480	0.76	429	0.68

EF = Front extended terminals
HR = Rear flat horizontal terminals
VR = Rear flat vertical terminals

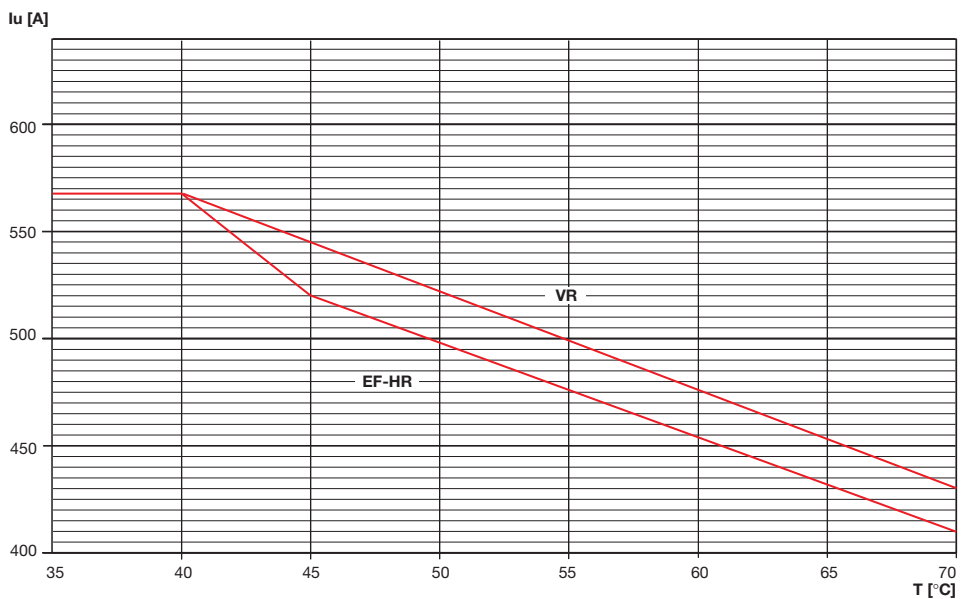

1SDC210699F001

T6 630 and T6D 630

Fixed

FC - F
R (VR)
R (HR)

FC = Front cables terminals
R (VR) = Rear terminals (vertical)

up to 40 °C		50 °C		60 °C		70 °C	
I _{max} [A]	I ₁	I _{max} [A]	I ₁	I _{max} [A]	I ₁	I _{max} [A]	I ₁
630	1	630	1	598.5	0.95	567	0.9
630	1	630	1	630	1	598.5	0.95
630	1	630	1	567	0.9	504	0.8

F = Front flat terminals

R (HR) = Rear terminals (horizontal)

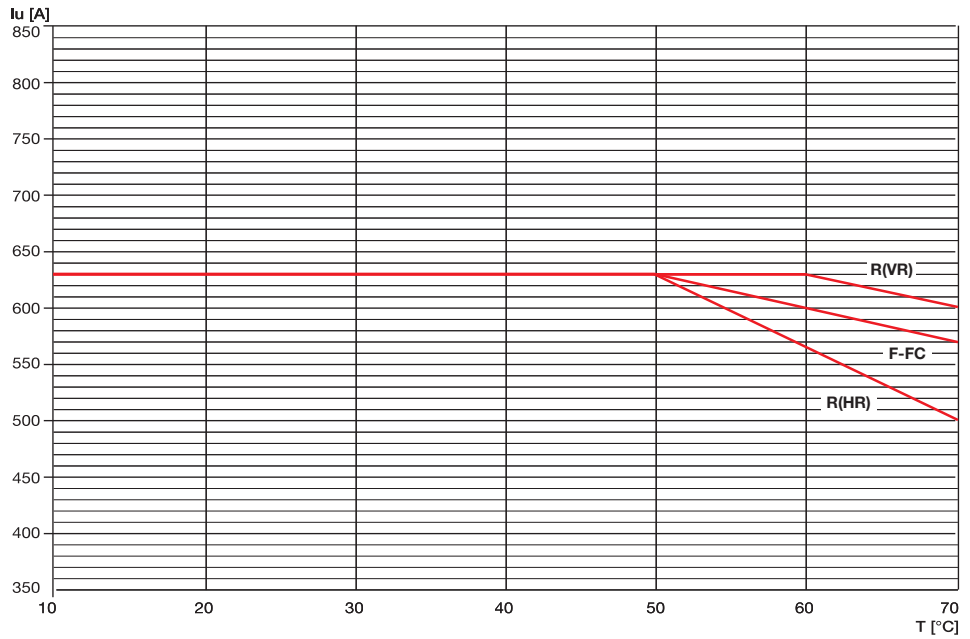

T6 630 and T6D 630

Withdrawable

EF
VR
HR

EF = Front extended terminals

up to 40 °C		50 °C		60 °C		70 °C	
I _{max} [A]	I ₁	I _{max} [A]	I ₁	I _{max} [A]	I ₁	I _{max} [A]	I ₁
630	1	598.5	0.95	567	0.9	504	0.8
630	1	630	1	598.5	0.95	567	0.9
630	1	598.5	0.95	567	0.9	504	0.8

HR = Rear flat horizontal terminals

VR = Rear flat vertical terminals

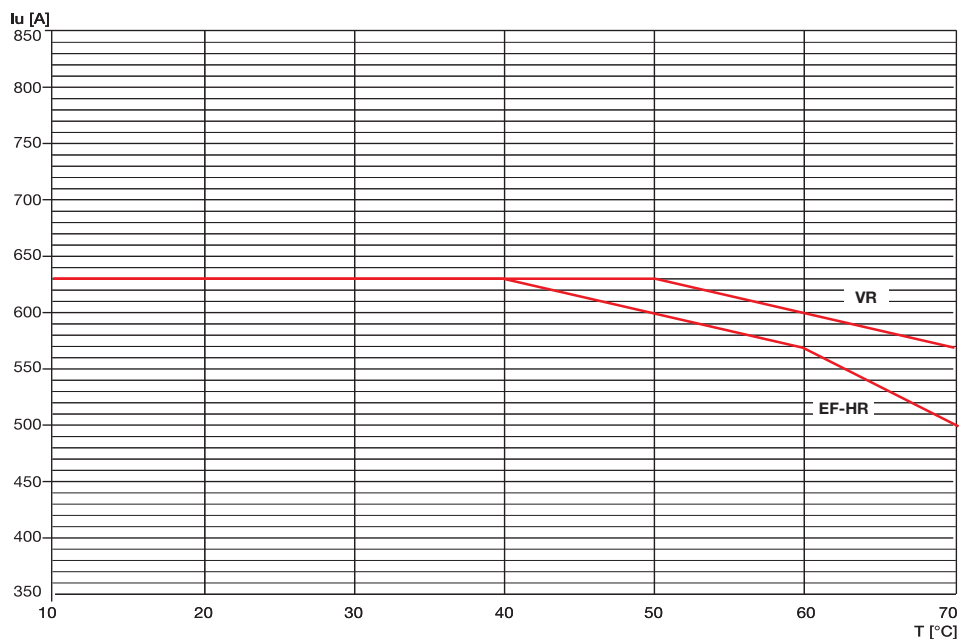

Temperature performances

Circuit-breakers with magnetic only or electronic trip units and switch-disconnectors

T6 800 and T6D 800

Fixed

	up to 40 °C		50 °C		60 °C		70 °C	
	I_{max} [A]	I_t	I_{max} [A]	I_t	I_{max} [A]	I_t	I_{max} [A]	I_t
FC - F	800	1	800	1	760	0.95	720	0.9
R (VR)	800	1	800	1	800	1	760	0.95
R (HR)	800	1	800	1	720	0.9	640	0.8

FC = Front cables terminals
R (VR) = Rear terminals (vertical)
F = Front flat terminals
R (HR) = Rear terminals (horizontal)

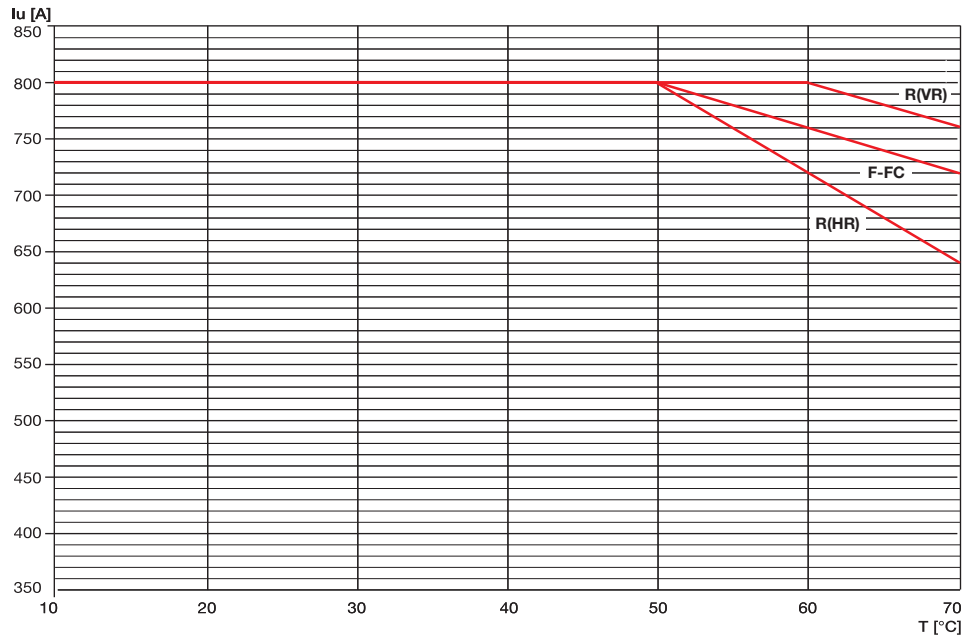

1SDC210F000001

T6 800 and T6D 800

Withdrawable

	up to 40 °C		50 °C		60 °C		70 °C	
	I_{max} [A]	I_t	I_{max} [A]	I_t	I_{max} [A]	I_t	I_{max} [A]	I_t
EF	800	1	760	0.95	720	0.9	640	0.8
VR	800	1	800	1	760	0.95	720	0.9
HR	800	1	760	0.95	720	0.9	640	0.8

EF = Front extended terminals
HR = Rear flat horizontal terminals
VR = Rear flat vertical terminals

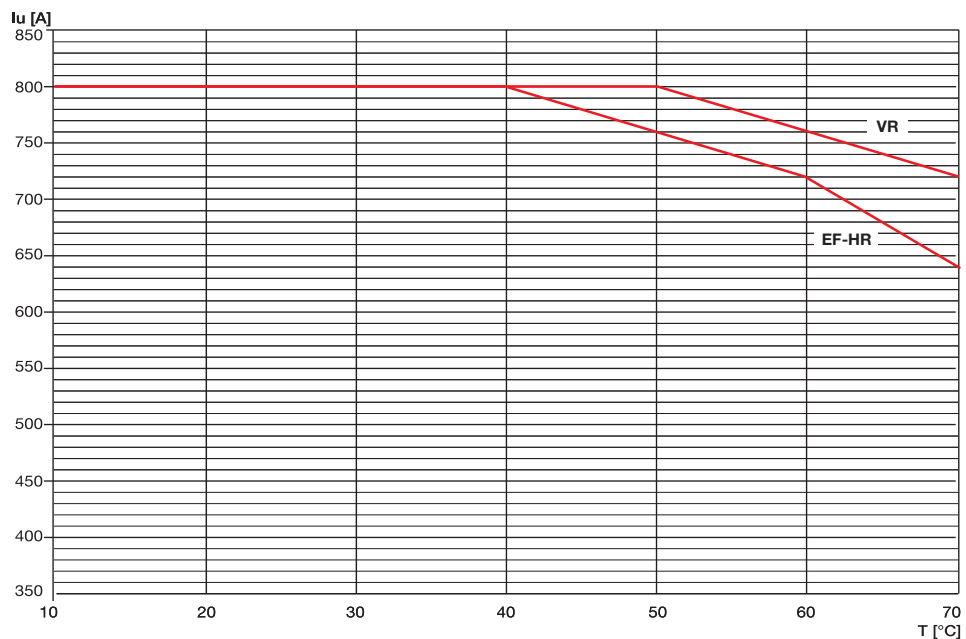

1SDC210F000001

T6 1000 and T6D 1000

Fixed

	up to 40 °C		50 °C		60 °C		70 °C	
	I_{max} [A]	I_1	I_{max} [A]	I_1	I_{max} [A]	I_1	I_{max} [A]	I_1
FC	1000	1	960	0.96	877	0.88	784	0.78
R (HR)	1000	1	926	0.93	845	0.85	756	0.76
R (VR)	1000	1	1000	1	913	0.91	817	0.82
ES	1000	1	900	0.90	820	0.82	720	0.72

FC = Front cables terminals
 ES = Front extended spread terminals

R (HR) = Rear terminals (horizontal)

R (VR) = Rear terminals (vertical)

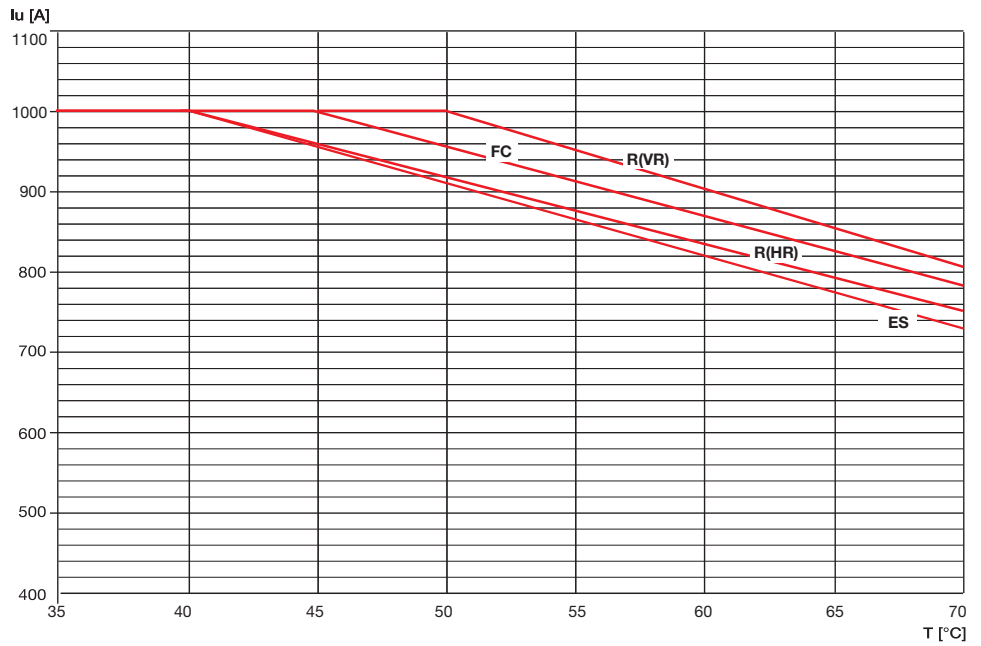

1SDC210015D0205

Temperature performances

Circuit-breakers with magnetic only or electronic trip units and switch-disconnectors

T7 S,H,L 800 and T7D 800

Fixed

	up to 40 °C		50 °C		60 °C		70 °C	
	I_{max} [A]	I_1	I_{max} [A]	I_1	I_{max} [A]	I_1	I_{max} [A]	I_1
VR	800	1	800	1	800	1	755	0.94
F-EF-HR	800	1	800	1	800	1	700	0.87

VR = Rear flat vertical
HR = Rear flat horizontal
F = Front flat terminals
EF = Extended front

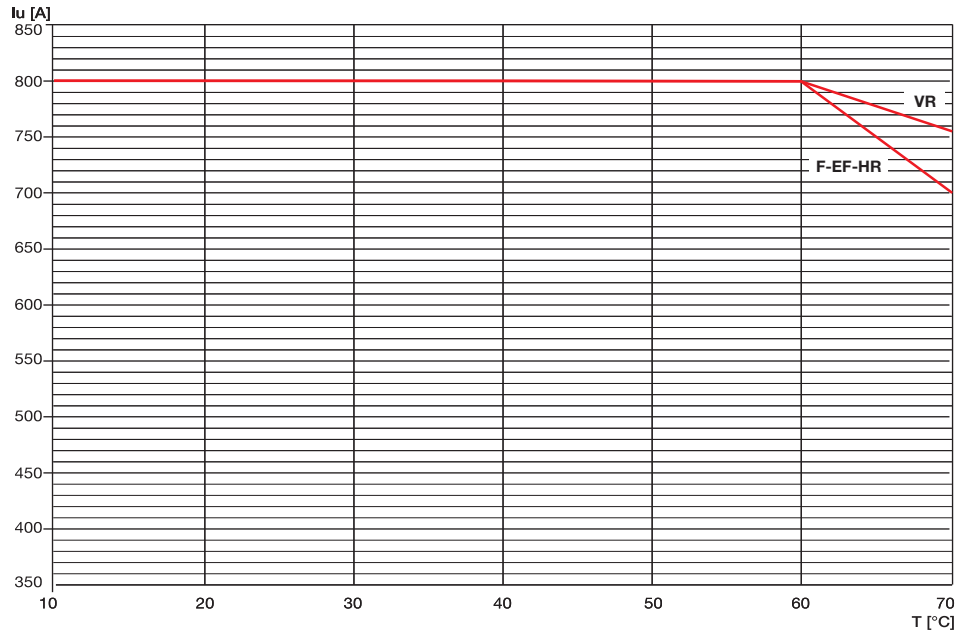

1SDC21001FFR001

T7 V 800

Fixed

	up to 40 °C		50 °C		60 °C		70 °C	
	I_{max} [A]	I_1	I_{max} [A]	I_1	I_{max} [A]	I_1	I_{max} [A]	I_1
VR	800	1	800	1	800	1	755	0.94
F-EF-HR	800	1	800	1	800	1	700	0.87

VR = Rear flat vertical
HR = Rear flat horizontal
F = Front flat terminals
EF = Extended front

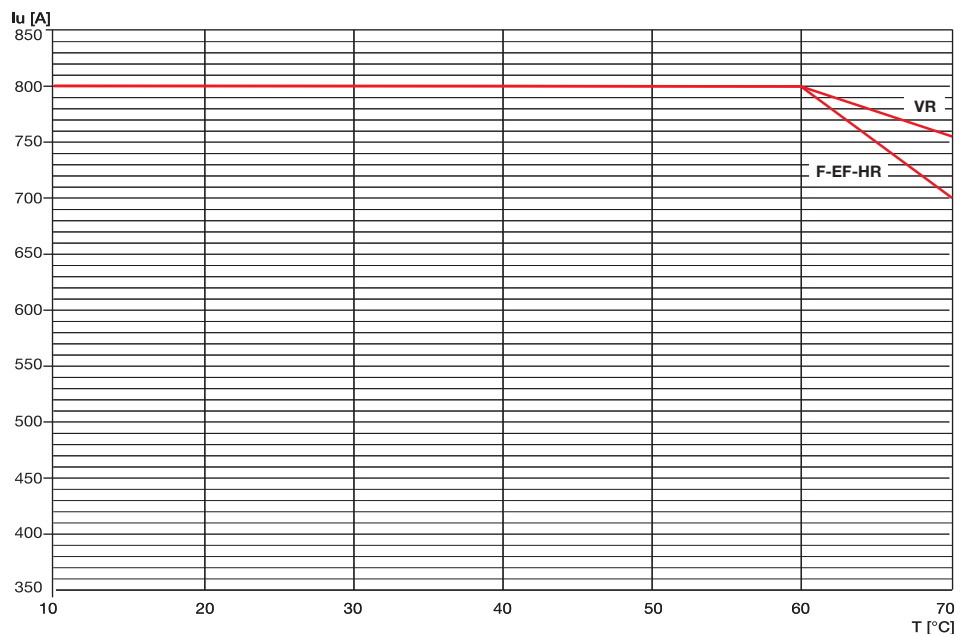

1SDC21001FFR001

T7 S,H,L 800 and T7D 800

Withdrawable

VR
F-EF-HR

VR = Rear flat vertical
HR = Rear flat horizontal

up to 40 °C		50 °C		60 °C		70 °C	
I _{max} [A]	I ₁	I _{max} [A]	I ₁	I _{max} [A]	I ₁	I _{max} [A]	I ₁
800	1	800	1	800	1	718	0.89
800	1	800	1	800	1	700	0.87

F = Front flat terminals

EF = Extended front

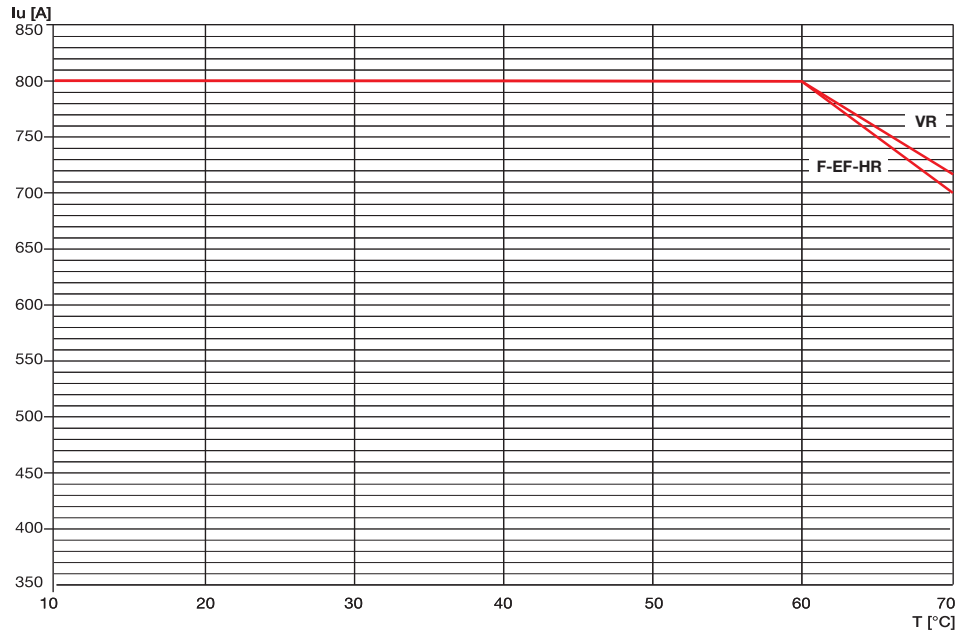

1SDC21038FF0001

T7 V 800

Withdrawable

VR
F-EF-HR

VR = Rear flat vertical
HR = Rear flat horizontal

up to 40 °C		50 °C		60 °C		70 °C	
I _{max} [A]	I ₁	I _{max} [A]	I ₁	I _{max} [A]	I ₁	I _{max} [A]	I ₁
800	1	800	1	800	1	716	0.89
800	1	800	1	763	0.95	682	0.85

F = Front flat terminals

EF = Extended front

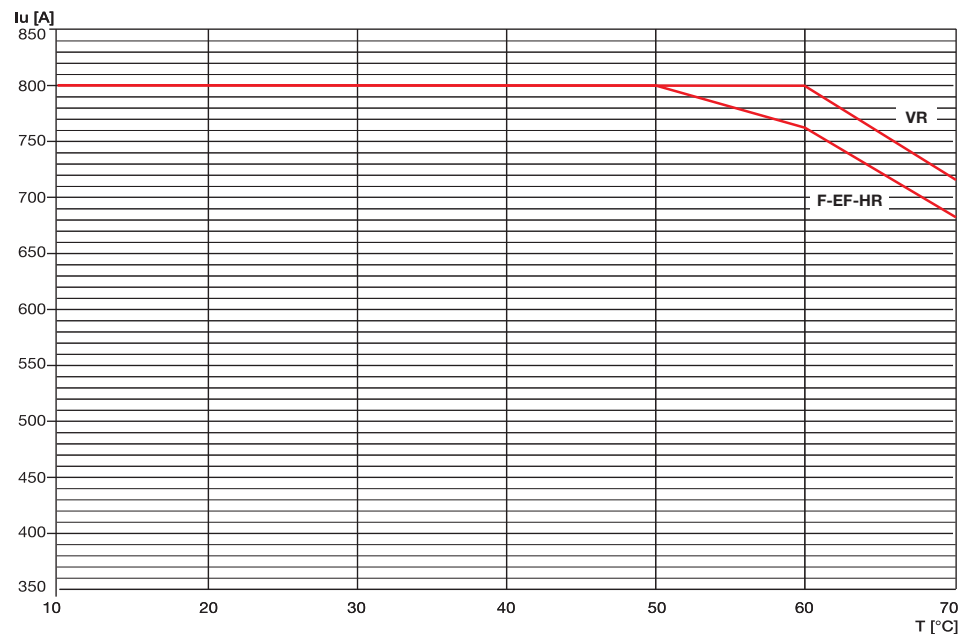

1SDC21038FF0001

Temperature performances

Circuit-breakers with magnetic only or electronic trip units and switch-disconnectors

T7 S,H,L 1000 and T7D 1000

Fixed

	up to 40 °C		50 °C		60 °C		70 °C	
	I _{max} [A]	I _t	I _{max} [A]	I _t	I _{max} [A]	I _t	I _{max} [A]	I _t
VR	1000	1	1000	1	1000	1	942	0.94
F-EF-HR	1000	1	1000	1	942	0.94	827	0.83

VR = Rear flat vertical
HR = Rear flat horizontal
F = Front flat terminals
EF = Extended front

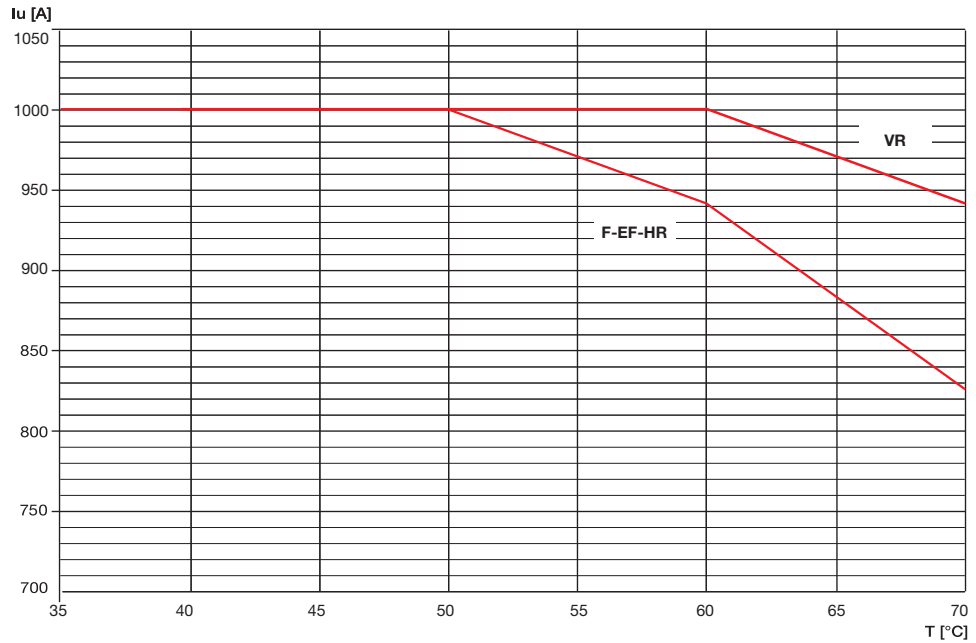

1SDC21034FF001

T7 S,H,L 1000 and T7D 1000

Withdrawable

	up to 40 °C		50 °C		60 °C		70 °C	
	I _{max} [A]	I _t	I _{max} [A]	I _t	I _{max} [A]	I _t	I _{max} [A]	I _t
VR	1000	1	1000	1	952	0.95	852	0.85
F-EF-HR	1000	1	1000	1	942	0.94	827	0.83

VR = Rear flat vertical
HR = Rear flat horizontal
F = Front flat terminals
EF = Extended front

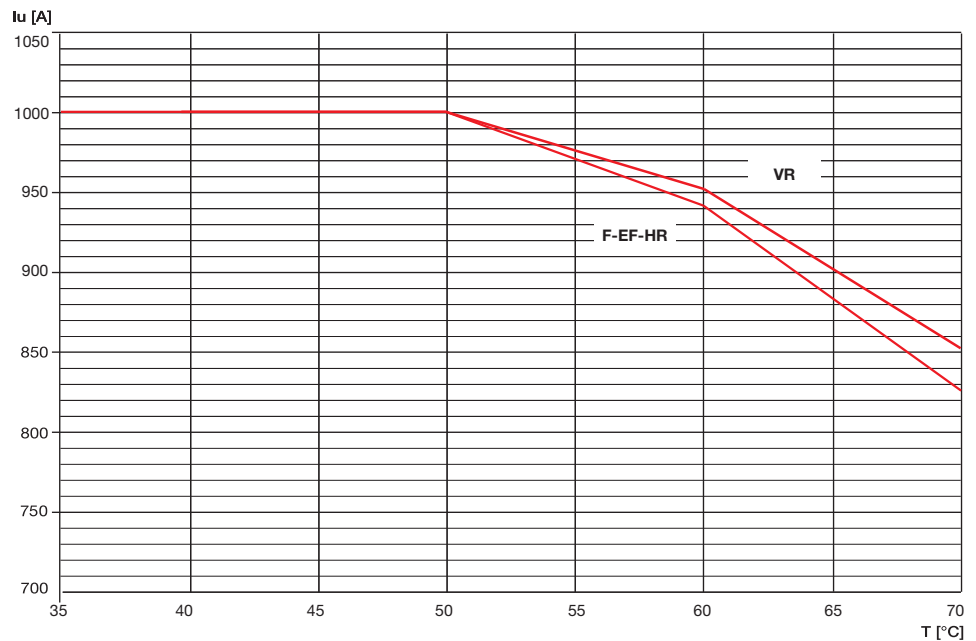

1SDC21035FF001

T7 V 1000

Fixed

	up to 40 °C		50 °C		60 °C		70 °C	
	I_{max} [A]	I_f	I_{max} [A]	I_f	I_{max} [A]	I_f	I_{max} [A]	I_f
VR	1000	1	1000	1.00	1000	1.00	894	0.89
EF-HR	1000	1	1000	1.00	895	0.89	784	0.78

EF = Extended front

VR = Rear flat vertical

HR = Rear flat horizontal

Note: For ratings below 1000 A Tmax T7 does not undergo any thermal derating.

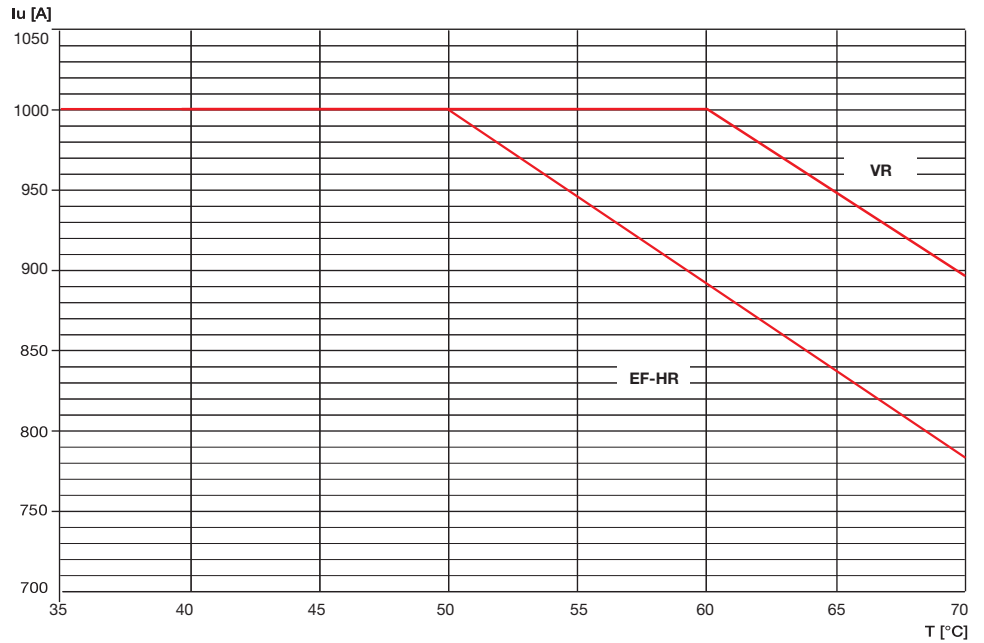

T7 V 1000

Withdrawable

	up to 40 °C		50 °C		60 °C		70 °C	
	I_{max} [A]	I_f	I_{max} [A]	I_f	I_{max} [A]	I_f	I_{max} [A]	I_f
VR	1000	1	1000	1.00	913	0.91	816	0.82
EF-HR	1000	1	1000	1.00	895	0.89	784	0.78

EF = Extended front

VR = Rear flat vertical

HR = Rear flat horizontal

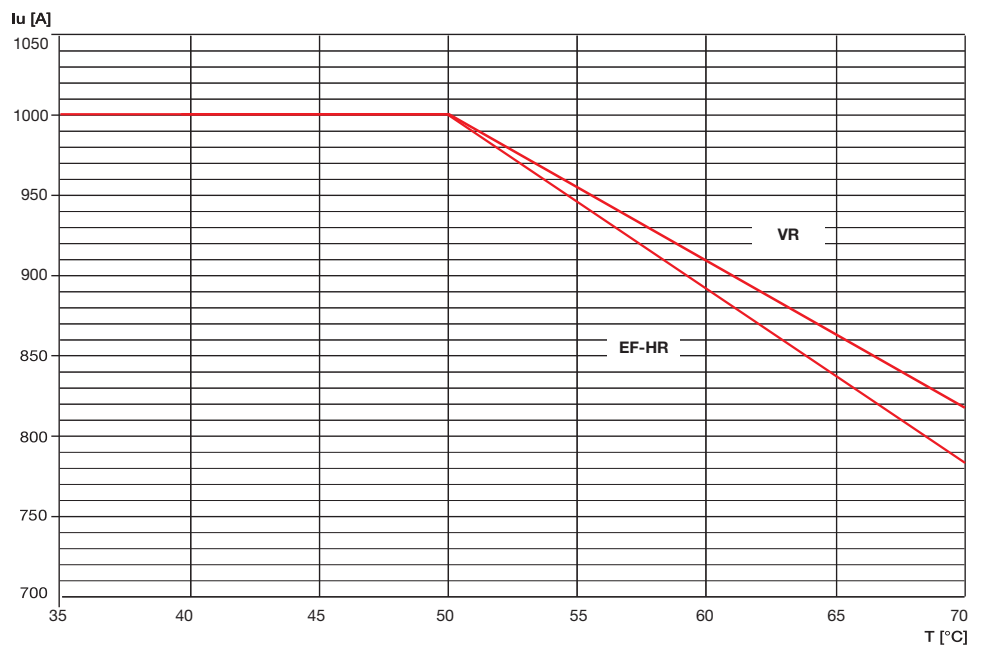

1SDC210554F0001

1SDC210554F0001

Temperature performances

Circuit-breakers with magnetic only or electronic trip units and switch-disconnectors

T7 S,H,L, 1250 and T7D 1250

Fixed

	up to 40 °C		50 °C		60 °C		70 °C	
	I_{max} [A]	I_t	I_{max} [A]	I_t	I_{max} [A]	I_t	I_{max} [A]	I_t
VR	1250	1	1250	1.00	1250	1.00	1118	0.89
EF-HR	1250	1	1250	1.00	1118	0.89	980	0.78

EF = Extended front VR = Rear flat vertical HR = Rear flat horizontal

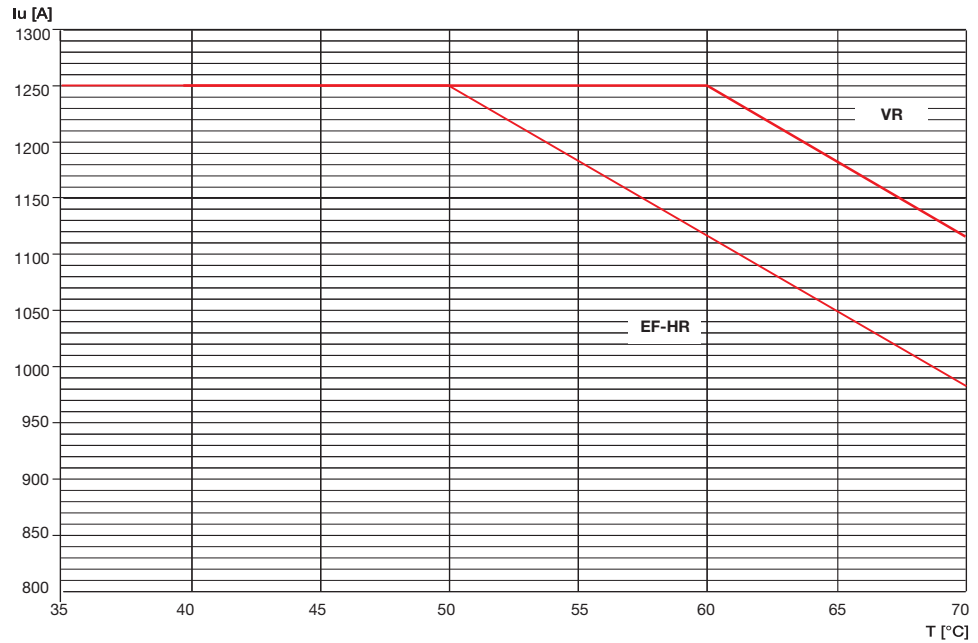

1SDC210F55F0001

T7 V 1250

Fixed

	up to 40 °C		50 °C		60 °C		70 °C	
	I_{max} [A]	I_t	I_{max} [A]	I_t	I_{max} [A]	I_t	I_{max} [A]	I_t
VR	1250	1	1201	0.96	1096	0.88	981	0.78
EF-HR	1250	1	1157	0.93	1056	0.85	945	0.76

EF = Extended front VR = Rear flat vertical HR = Rear flat horizontal

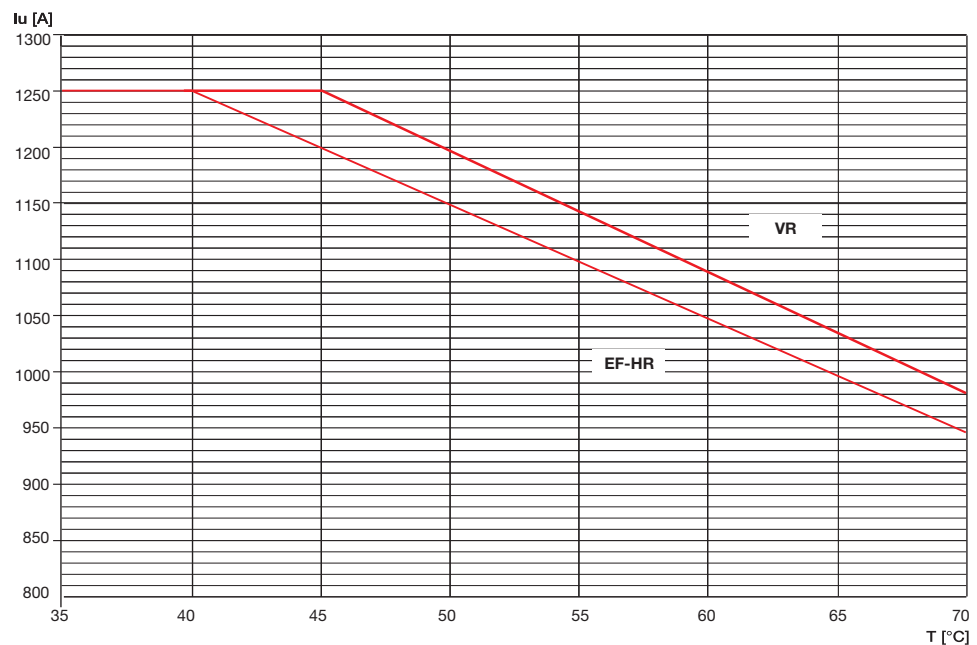

1SDC210F56F0001

T7 S,H,L, 1250 and T7D 1250

Withdrawable

	up to 40 °C		50 °C		60 °C		70 °C	
	I_{max} [A]	I_1	I_{max} [A]	I_1	I_{max} [A]	I_1	I_{max} [A]	I_1
VR	1250	1	1250	1.00	1141	0.91	1021	0.82
EF-HR	1250	1	1250	1.00	1118	0.89	980	0.78

EF = Extended front VR = Rear flat vertical HR = Rear flat horizontal

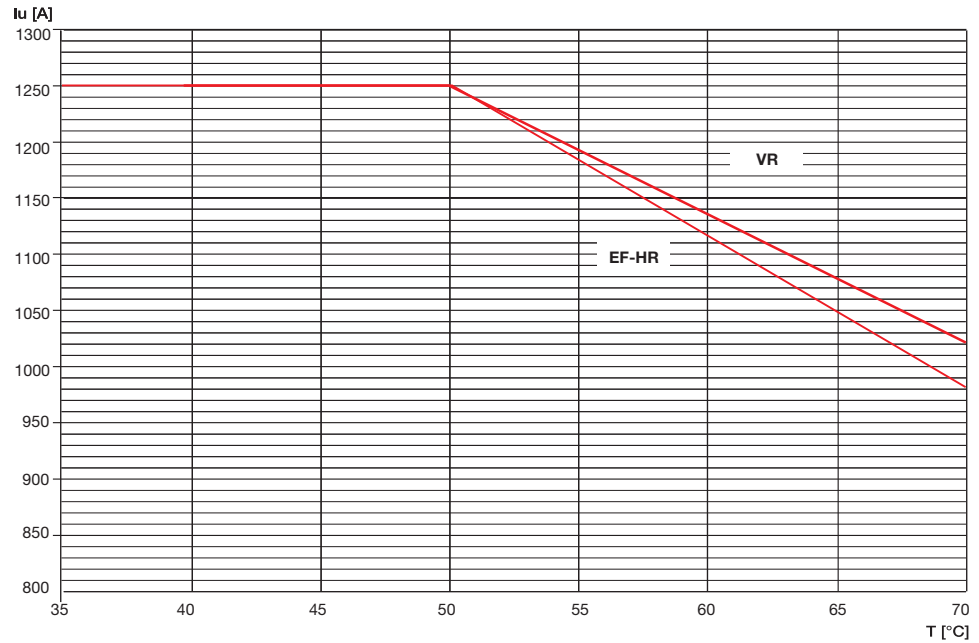

T7 V 1250

Withdrawable

	up to 40 °C		50 °C		60 °C		70 °C	
	I_{max} [A]	I_1	I_{max} [A]	I_1	I_{max} [A]	I_1	I_{max} [A]	I_1
VR	1250	1	1157	0.93	1056	0.85	945	0.76
EF-HR	1250	1	1000	0.80	913	0.73	816	0.65

EF = Extended front VR = Rear flat vertical HR = Rear flat horizontal

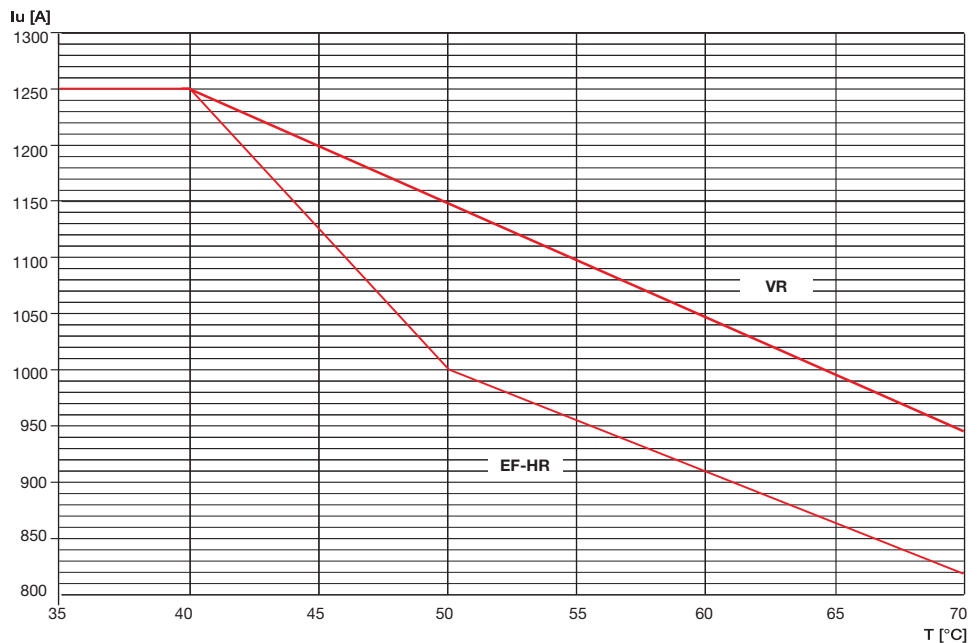

1SDC2105570001

1SDC2105590001

Temperature performances

Circuit-breakers with magnetic only or electronic trip units and switch-disconnectors

T7 S,H,L, 1600 and T7D 1600

Fixed

	up to 40 °C		50 °C		60 °C		70 °C	
	I_{max} [A]	I_t	I_{max} [A]	I_t	I_{max} [A]	I_t	I_{max} [A]	I_t
VR	1600	1	1537	0.96	1403	0.88	1255	0.78
EF-HR	1600	1	1481	0.93	1352	0.85	1209	0.76

EF = Extended front VR = Rear flat vertical HR = Rear flat horizontal

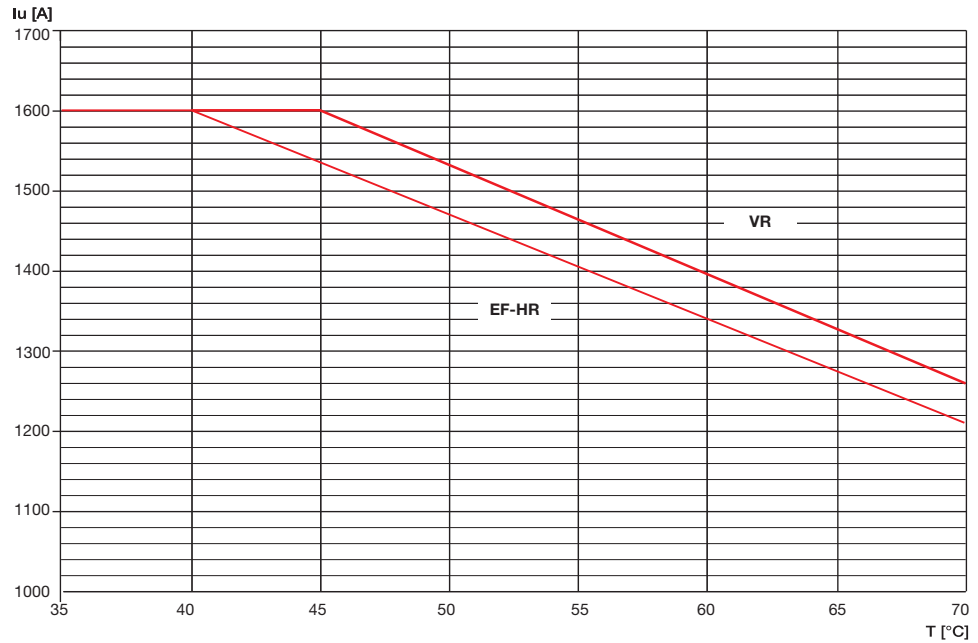

1SDC21015D0205

T7 S,H,L, 1600 and T7D 1600

Withdrawable

	up to 40 °C		50 °C		60 °C		70 °C	
	I_{max} [A]	I_t	I_{max} [A]	I_t	I_{max} [A]	I_t	I_{max} [A]	I_t
VR	1600	1	1481	0.93	1352	0.85	1209	0.76
EF-HR	1600	1	1280	0.80	1168	0.73	1045	0.65

EF = Extended front VR = Rear flat vertical HR = Rear flat horizontal

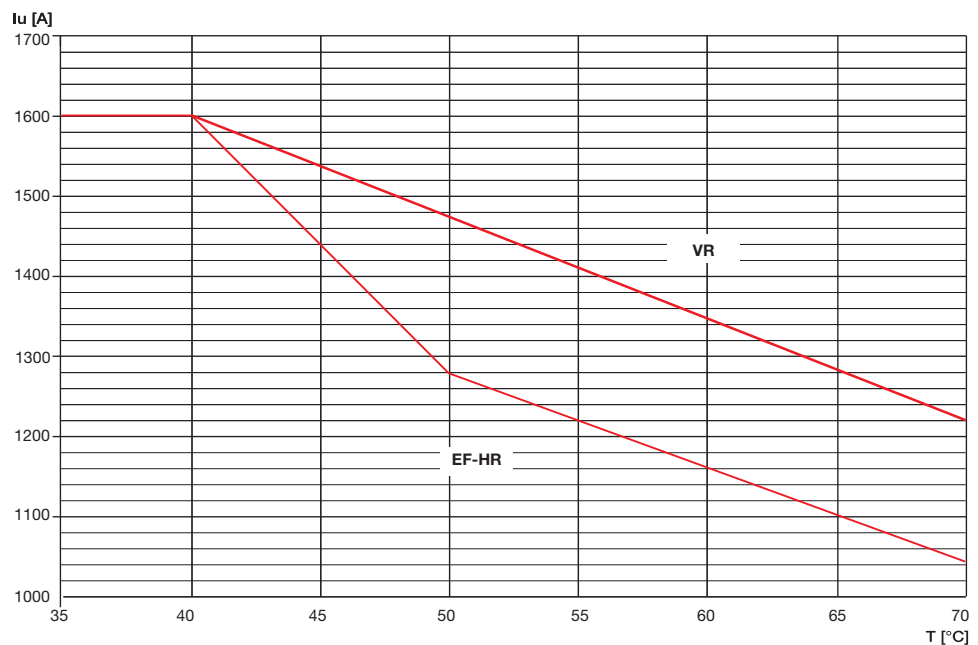

1SDC21015D0205

Temperature performances

Circuit-breakers with thermomagnetic trip units

Tmax T1 and T1 1P⁽¹⁾

In [A]	10 °C		20 °C		30 °C		40 °C		50 °C		60 °C		70 °C	
	MIN	MAX	MIN	MAX	MIN	MAX	MIN	MAX	MIN	MAX	MIN	MAX	MIN	MAX
16	13	18	12	18	12	17	11	16	11	15	10	14	9	13
20	16	23	15	22	15	21	14	20	13	19	12	18	11	16
25	20	29	19	28	18	26	18	25	16	23	15	22	14	20
32	26	37	25	35	24	34	22	32	21	30	20	28	18	26
40	32	46	31	44	29	42	28	40	26	38	25	35	23	33
50	40	58	39	55	37	53	35	50	33	47	31	44	28	41
63	51	72	49	69	46	66	44	63	41	59	39	55	36	51
80	64	92	62	88	59	84	56	80	53	75	49	70	46	65
100	81	115	77	110	74	105	70	100	66	94	61	88	57	81
125	101	144	96	138	92	131	88	125	82	117	77	109	71	102
160	129	184	123	176	118	168	112	160	105	150	98	140	91	130

⁽¹⁾ For the T1 1p circuit-breaker (fitted with TMF fixed thermomagnetic trip unit), only consider the column corresponding to the maximum adjustment of the TMD trip units.

Tmax T2

In [A]	10 °C		20 °C		30 °C		40 °C		50 °C		60 °C		70 °C	
	MIN	MAX	MIN	MAX	MIN	MAX	MIN	MAX	MIN	MAX	MIN	MAX	MIN	MAX
1.6	1.3	1.8	1.2	1.8	1.2	1.7	1.1	1.6	1	1.5	1	1.4	0.9	1.3
2	1.6	2.3	1.5	2.2	1.5	2.1	1.4	2	1.3	1.9	1.2	1.7	1.1	1.6
2.5	2	2.9	1.9	2.8	1.8	2.6	1.8	2.5	1.6	2.3	1.5	2.2	1.4	2
3.2	2.6	3.7	2.5	3.5	2.4	3.4	2.2	3.2	2.1	3	1.9	2.8	1.8	2.6
4	3.2	4.6	3.1	4.4	2.9	4.2	2.8	4	2.6	3.7	2.4	3.5	2.3	3.2
5	4	5.7	3.9	5.5	3.7	5.3	3.5	5	3.3	4.7	3	4.3	2.8	4
6.3	5.1	7.2	4.9	6.9	4.6	6.6	4.4	6.3	4.1	5.9	3.8	5.5	3.6	5.1
8	6.4	9.2	6.2	8.8	5.9	8.4	5.6	8	5.2	7.5	4.9	7	4.5	6.5
10	8	11.5	7.7	11	7.4	10.5	7	10	6.5	9.3	6.1	8.7	5.6	8.1
12.5	10.1	14.4	9.6	13.8	9.2	13.2	8.8	12.5	8.2	11.7	7.6	10.9	7.1	10.1
16	13	18	12	18	12	17	11	16	10	15	10	14	9	13
20	16	23	15	22	15	21	14	20	13	19	12	17	11	16
25	20	29	19	28	18	26	18	25	16	23	15	22	14	20
32	26	37	25	35	24	34	22	32	21	30	19	28	18	26
40	32	46	31	44	29	42	28	40	26	37	24	35	23	32
50	40	57	39	55	37	53	35	50	33	47	30	43	28	40
63	51	72	49	69	46	66	44	63	41	59	38	55	36	51
80	64	92	62	88	59	84	56	80	52	75	49	70	45	65
100	80	115	77	110	74	105	70	100	65	93	61	87	56	81
125	101	144	96	138	92	132	88	125	82	117	76	109	71	101
160 ⁽¹⁾	129	184	123	178	118	168	112	160	105	150	97	139	90	129

⁽¹⁾ For CB in plug-in version further 10% derating.

Tmax T3

In [A]	10 °C		20 °C		30 °C		40 °C		50 °C		60 °C		70 °C	
	MIN	MAX	MIN	MAX	MIN	MAX	MIN	MAX	MIN	MAX	MIN	MAX	MIN	MAX
63	51	72	49	69	46	66	44	63	41	59	38	55	35	51
80	64	92	62	88	59	84	56	80	52	75	48	69	45	64
100	80	115	77	110	74	105	70	100	65	93	61	87	56	80
125	101	144	96	138	92	132	88	125	82	116	76	108	70	100
160	129	184	123	176	118	168	112	160	104	149	97	139	90	129
200	161	230	154	220	147	211	140	200	130	186	121	173	112	161
250	201	287	193	278	184	263	175	250	163	233	152	216	141	201

⁽¹⁾ For CB in plug-in version further 10% derating.

Temperature performances

Circuit-breakers with thermomagnetic trip units

Tmax T4

In [A]	10 °C		20 °C		30 °C		40 °C		50 °C		60 °C		70 °C	
	MIN	MAX	MIN	MAX	MIN	MAX	MIN	MAX	MIN	MAX	MIN	MAX	MIN	MAX
20	19	27	18	24	16	23	13	20	12	17	10	15	8	13
32	26	43	24	39	22	36	20	32	16	27	14	24	11	21
50	37	62	35	58	33	54	32	50	27	46	25	42	22	39
80	59	98	55	92	52	86	50	80	44	74	40	66	32	58
100	83	118	80	113	74	106	70	100	66	95	59	85	49	75
125	103	145	100	140	94	134	88	125	80	115	73	105	63	95
160	130	185	124	176	118	168	112	160	106	150	100	140	90	130
200	162	230	155	220	147	210	140	200	133	190	122	175	107	160
250	200	285	193	275	183	262	175	250	168	240	160	230	150	220

Tmax T5

In [A]	10 °C		20 °C		30 °C		40 °C		50 °C		60 °C		70 °C	
	MIN	MAX	MIN	MAX	MIN	MAX	MIN	MAX	MIN	MAX	MIN	MAX	MIN	MAX
320	260	368	245	350	234	335	224	320	212	305	200	285	182	263
400	325	465	310	442	295	420	280	400	265	380	250	355	230	325
500	435	620	405	580	380	540	350	500	315	450	280	400	240	345

Tmax T6

In [A]	10 °C		20 °C		30 °C		40 °C		50 °C		60 °C		70 °C	
	MIN	MAX	MIN	MAX	MIN	MAX	MIN	MAX	MIN	MAX	MIN	MAX	MIN	MAX
630	520	740	493	705	462	660	441	630	405	580	380	540	350	500
800	685	965	640	905	605	855	560	800	520	740	470	670	420	610

Power losses

Power [W/pole]	In [A]	T1/T1 1P	T2		T3		T4		T5		T6		T7 S,H,L		T7 V	
		F	F	P	F	P	F	P/W	F	P/W	F	W	F	W	F	W
TMD	1		1.5	1.7												
TMA	1.6		2.1	2.5												
TMG	2		2.5	2.9												
MF	2.5		2.6	3												
MA	3.2		2.9	3.4												
	4		2.6	3												
	5		2.9	3.5												
	6.3		3.5	4.1												
	8		2.7	3.2												
	10		3.1	3.6												
	12.5		1.1	1.3												
	16	1.5	1.4	1.6												
	20	1.8	1.7	2			3.6	3.6								
	25	2	2.3	2.8												
	32	2.1	2.7	3.2			3.7	3.7								
	40	2.6	3.9	4.6												
	50	3.7	4.3	5			3.9	4.1								
	63	4.3	5.1	6	4.3	5.1										
	80	4.8	6.1	7.2	4.8	5.8	4.6	5								
	100	7	8.5	10	5.6	6.8	5.2	5.8								
	125	10.7	12	14.7	6.6	7.9	6.2	7.2								
	160	15	17	20	7.9	9.5	7.4	9								
	200				13.2	15.8	9.9	12.4								
	250				17.8	21.4	13.7	17.6								
	320								13.6	20.9						
	400								19.5	31						
	500								28.8	36.7						
	630										30.6	39				
	800										31	39.6				
PR22..	10		0.5	0.6												
PR23..	25		1	1.2												
PR33..	63		3.5	4												
	100		8	9.2			1.7	2.3								
	160		17	20			4.4	6								
	250						10.7	14.6								
	320						17.6	24	10.6	17.9						
	400								16.5	28			5	9	8	12
	630								41	53.6	30	38.5	12	22	20	30
	800										32	41.6	19.3	35.3	32	48
	1000										50		30	55	50	75
	1250												47	86	78.3	117.3
	1600												77	141		

Magnetic trip values

	Release	I_n [A]	I_3 [A]	Single-phase trip current (% I_3) ⁽¹⁾	
T1 1p 160	TMF	16...160	500...1600		
T1 160	TMD	16...50	500	150%	
		16...50	630 ⁽²⁾	200%	
		63...160	630...1600	200%	
T2 160	TMD	1.6...25	16...500	200%	
		32...50	500	180%	
		63...160	630...1600	150%	
	MF/MA	1...20	13...240	200%	
		32...52	192...624	180%	
		80...100	480...1200	150%	
T3 250	PR221	10...160	1...10 x I_n	100%	
	TMG	63...250	400...750	150%	
	TMD	63...250	630...2500	150%	
	MA	100...200	600...2400	150%	
T4 250/320	TMD	20...50	320...500	150%	
		TMA	80...250	400...2500	150%
		MA	10...200	60...2800	150%
	PR221DS	100...320	1...10 x I_n	100%	
	PR222DS/P-PR222DS/PD	100...320	1...12 x I_n	100%	
	PR223DS	100...320	1.5...12 x I_n	100%	
T5 400/630	TMG	320...500	1600...2500	150%	
		TMA	320...500	3200...5000	150%
		PR221DS	320...630	1...10 x I_n	100%
	PR222DS/P-PR222DS/PD	320...630	1...12 x I_n	100%	
	PR223DS	320...630	1.5...12 x I_n	100%	
	T6 630/800/1000	TMA	630...800	3150...8000	150%
PR221DS			630...1000	1...10 x I_n	100%
PR222DS/P-PR222DS/PD		630...1000	1...12 x I_n	100%	
PR223DS		630...1000	1.5...12 x I_n	100%	
T7 800/1000/1250/1600	PR231/P-PR232/P	400...1600	1.5...12 x I_n	100%	
	PR331/P-PR332/P	400...1600	1.5...15 x I_n	100%	

I_3 = instantaneous trip current
 TMF = thermomagnetic release with fixed thermal and magnetic threshold
 TMD = thermomagnetic release with adjustable thermal and fixed magnetic threshold
 TMA = thermomagnetic release with adjustable thermal and magnetic threshold
 TMG = thermomagnetic release for generator protection
 PR22_, PR23_, PR33_ = electronic releases

⁽¹⁾ Satisfies the requirements of the IEC 60947-2 Standard, section 8.3.3.1.2

⁽²⁾ Only T1B and T1C

Special applications

Use of apparatus at 16 2/3 Hz

The series of thermomagnetic Tmax circuit-breakers are suitable for operation at 16 2/3 Hz frequencies - an application mainly used in the railway sector.

The electrical performances are given below (Breaking capacity I_{cu}) according to the voltage and the number of poles to be connected in series with reference to the connection diagrams.

I _{cu} [kA]	Connection diagram	T1			T2				T3		T4					T5					T6			
		B	C	N	N	S	H	L	N	S	N	S	H	L	V	N	S	H	L	V	N	S	H	L
250 V (AC) 2 poles in series	A	16	25	36	36	50	70	85	36	50	36	50	70	100	150	36	50	70	100	150	36	50	70	100
250 V (AC) 3 poles in series	B-C	20	30	40	40	55	85	100	40	55	-	-	-	-	-	-	-	-	-	-	-	-	-	-
500 V (AC) 2 poles in series	A	-	-	-	-	-	-	-	-	-	25	36	50	70	100	25	36	50	70	100	20	35	50	70
500 V (AC) 3 poles in series	B-C	16	25	36	36	50	70	85	36	50	-	-	-	-	-	-	-	-	-	-	-	-	-	
750 V (AC) 3 poles in series	B-C	-	-	-	-	-	-	-	-	-	16	25	36	50	70	16	25	36	50	70	16	20	36	50
750 V (AC) 4 poles in series ⁽¹⁾	D	-	-	-	-	-	-	50	-	-	-	-	-	-	-	-	-	-	-	-	-	-	-	
1000 V (AC) 4 poles in series ⁽²⁾	D	-	-	-	-	-	-	-	-	-	-	-	-	40	-	-	-	-	40	-	-	-	40	

⁽¹⁾ Circuit-breakers with neutral at 100%
⁽²⁾ Use 1000 V DC version circuit-breakers

Connection diagrams

Diagram A: Interruption with one pole for polarity

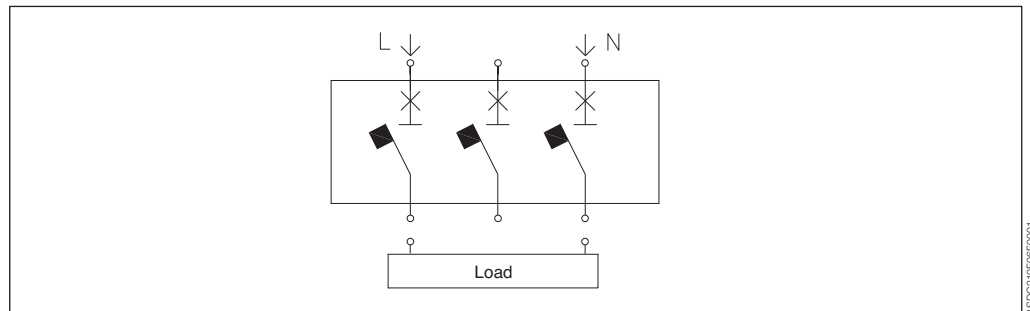

Note: Without neutral connected to earth, the installation method must be such as to make the probability of a second earth fault nil.

Diagram B: Interruption with two poles in series for one polarity and one pole for the other polarity

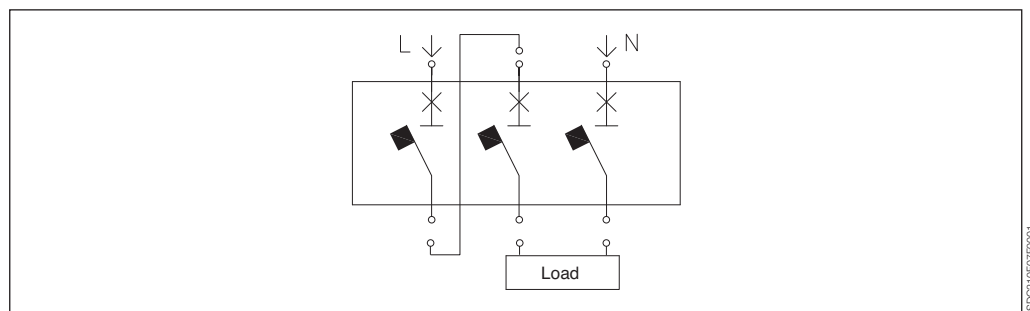

Note: Without neutral connected to earth, the installation method must be such as to make the probability of a second earth fault nil.

1SDC210015D0205

1SDC210015D0205

Special applications

Use of apparatus at 16 2/3 Hz

Diagram C: Interruption with three poles in series for one polarity (with neutral earthed)

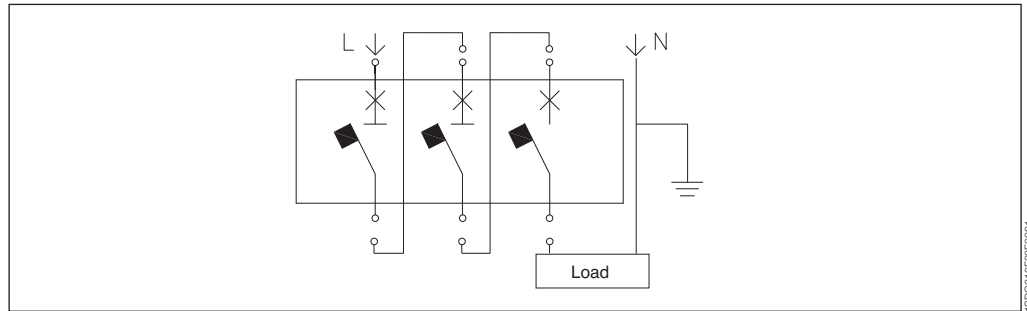

Diagram D: Interruption with four poles in series for one polarity (with neutral earthed)

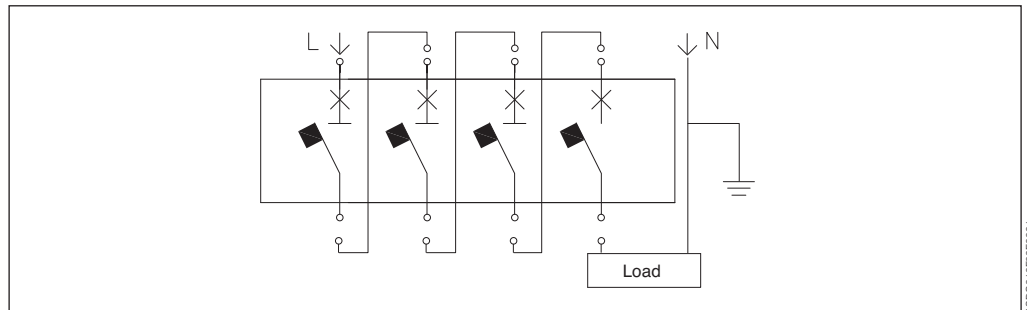
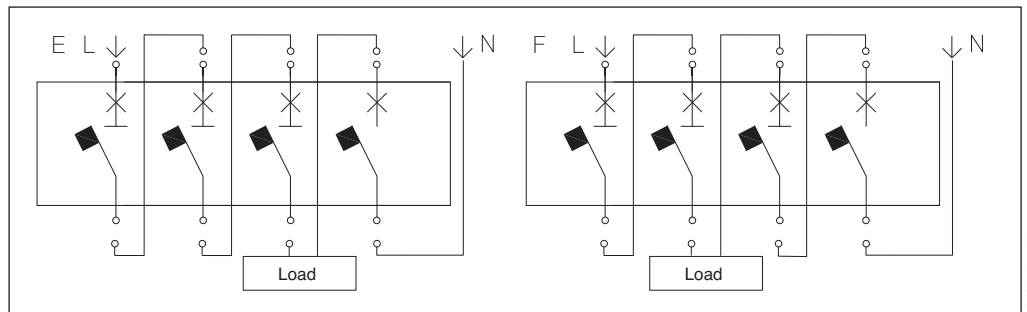

Diagram E: Interruption with three poles in series for one polarity and one pole for the other polarity, and interruption with two poles in series for each polarity



Note: Without neutral connected to earth, the installation method must be such as to make the probability of a second earth fault negligible

Trip thresholds

The thermal threshold of the circuit-breaker is the same as the normal version.

For the magnetic threshold, a correction coefficient must be used to be made on the protection thresholds as indicated in the table:

Circuit-breaker	Diagram A	Diagram B-C	Diagram D
T1	1	1	–
T2	0.9	0.9	0.9
T3	0.9	0.9	–
T4	0.9	0.9	0.9
T5	0.9	0.9	0.9

Setting adjustment of the magnetic threshold

The correction factor takes into consideration the phenomena that, with frequencies differing from 50-60 Hz, modifies the tripping value of protection threshold against short circuit. The value that must be set on the trip unit is therefore the real wanted tripping value divided by the correction factor.

Example

- Service current: $I_b = 200 \text{ A}$
- Circuit-breaker: T4 250 In = 250 A
- Desired magnetic protection: $I_3 = 2000 \text{ A}$
- Magnetic threshold value to be set:

$$\text{Set: } \frac{I_3}{k_m}$$

therefore in this specific case, the setting for the adjustment value for the magnetic threshold is:

$$\text{Set: } \frac{2000}{0.9} = 2222 \text{ A (roughly equal to } 9 I_n)$$

Special applications

Use of apparatus at 400 Hz

At high frequencies, the performances of the circuit-breakers are reclassified to take the following phenomena into account:

- the increase in the skin effect and increase in the inductive reactance, in a way directly proportional to the frequency, cause overheating of the conductor or of the copper components which normally carry the current in the circuit-breaker;
- the elongation of the hysteresis ring and the reduction in the magnetic saturation value, with consequent variation in the forces associated with the magnetic field at a given current value.

In general, these phenomena have effects on the behaviour of both the thermomagnetic releases and of the elements of the circuit-breaker for interrupting the current.

The following tables refer to circuit-breakers with thermomagnetic releases, with a breaking capacity of less than 36 kA. This value is normally more than sufficient for protection of 400 Hz plants, normally characterised by fairly low short-circuit currents.

As can be seen from the data indicated, the trip threshold of the thermal component (I_n) decreases as the frequency increases due to the reduced conductivity of the materials and to the increase in associated thermal phenomena. In general, derating of this performance is equal to 10%.

Vice versa, the magnetic threshold (I_3) increases as the frequency increases: for this reason, use of a 5- I_n version is recommended. In these tables, K_m is the multiplication factor of I_3 due to the induced magnetic fields.

T1 160 - TMD 16÷80 A

	I_1 (400 Hz)			I_3			
	I_n	MIN	MED	MAX	I_3 (50 Hz)	K_m	I_3 (400 Hz)
T1B 160	16	10	12	14	500	2	1000
T1C 160	20	12	15	18	500	2	1000
T1N 160	25	16	19	22	500	2	1000
	32	20	24.5	29	500	2	1000
	40	25	30.5	36	500	2	1000
	50	31	38	45	500	2	1000
	63	39	48	57	630	2	1260
	80	50	61	72	800	2	1600

T2 160 - TMD 1.6÷80 A

	I_1 (400 Hz)			I_3			
	I_n	MIN	MED	MAX	I_3 (50 Hz)	K_m	I_3 (400 Hz)
T2N 160	1.6	1	1.2	1.4	16	1.7	27.2
	2	1.2	1.5	1.8	20	1.7	34
	2.5	1.5	1.9	2.2	25	1.7	42.5
	3.2	2	2.5	2.9	32	1.7	54.4
	4	2.5	3	3.6	40	1.7	68
	5	3	3.8	4.5	50	1.7	85
	6.3	4	4.8	5.7	63	1.7	107.1
	8	5	6.1	7.2	80	1.7	136
	10	6.3	7.6	9	100	1.7	170
	12.5	7.8	9.5	11.2	125	1.7	212.5
	16	10	12	14	500	1.7	850
	20	12	15	18	500	1.7	850
	25	16	19	22	500	1.7	850
	32	20	24.5	29	500	1.7	850
	40	25	30.5	36	500	1.7	850
	50	31	38	45	500	1.7	850
	63	39	48	57	630	1.7	1071
	80	50	61	72	800	1.7	1360

T2 160 - TMG 16÷160 A

	I_1 (400 Hz)				I_3		
	In	MIN	MED	MAX	I_3 (50 Hz)	K_m	I_3 (400 Hz)
T2N 160	16	10	12	14	160	1.7	272
	25	16	19	22	160	1.7	272
	40	25	30.5	36	200	1.7	340
	63	39	48	57	200	1.7	340
	80	50	61	72	240	1.7	408
	100	63	76.5	90	300	1.7	510
	125	79	96	113	375	1.7	637.5
	160	100	122	144	480	1.7	816

T3 250 - TMG 63÷250 A

	I_1 (400 Hz)				I_3		
	In	MIN	MED	MAX	I_3 (50 Hz)	K_m	I_3 (400 Hz)
T3N 250	63	39	48	57	400	1.7	680
	80	50	61	72	400	1.7	680
	100	63	76.5	90	400	1.7	680
	125	79	96	113	400	1.7	680
	160	100	122	144	480	1.7	816
	200	126	153	180	600	1.7	1020
	250	157	191	225	750	1.7	1275

T3 250 - TMD 63÷125 A

	I_1 (400 Hz)				I_3		
	In	MIN	MED	MAX	I_3 (50 Hz)	K_m	I_3 (400 Hz)
T3N 250	80	50	61	72	800	1.7	1360
	100	63	76.5	90	1000	1.7	1700
	125	79	96	113	1250	1.7	2125

T4 250 - TMD 20÷50 A

	I_1 (400 Hz)				I_3		
	In	MIN	MED	MAX	I_3 (50 Hz)	K_m	I_3 (400 Hz)
T4N 250	20	12	15	18	320	1.7	544
	32	20	24.5	29	320	1.7	544
	50	31	38	45	500	1.7	850

T4 250/320 - TMA 80÷250 A

	I_1 (400 Hz)				I_3 settings (MIN=5xIn)		
	In	MIN	MED	MAX	I_3 (50 Hz)	K_m	I_3 (400 Hz)
T4N 250/320	80	50	61	72	400	1.7	680
	100	63	76.5	90	500	1.7	850
	125	79	96	113	625	1.7	1060
	160	100	122	144	800	1.7	1360
	200	126	153	180	1000	1.7	1700
	250	157	191	225	1250	1.7	2125

Special applications

Use of apparatus at 400 Hz

T5 400/630 - TMA 320÷500 A

	I_1 (400 Hz)				I_3 settings (MIN=5xIn)		
	In	MIN	MED	MAX	I_3 (50 Hz)	K_m	I_3 (400 Hz)
T5N	320	201	244	288	1600	1.5	2400
400/630	400	252	306	360	2000	1.5	3000
	500	315	382	450	2500	1.5	3750

T5 400/630 - TMG 320÷500 A

	I_1 (400 Hz)				I_3 settings (MIN=5xIn)		
	In	MIN	MED	MAX	I_3 (50 Hz)	K_m	I_3 (400 Hz)
T5N	320	201	244	288	800...1600	1.5	1200...2400
400/630	400	252	306	360	1000...2000	1.5	1500...3000
	500	315	382	450	1250...2500	1.5	1875...3750

T6 630/800 - TMA

	I_1 (400 Hz)				I_3 settings (MIN=5xIn)		
	In	MIN	MED	MAX	I_3 (50 Hz)	K_m	I_3 (400 Hz)
T6N 630	630	397	482	567	3150	1.5	4725
T6N 800	800	504	602	720	4000	1.5	6000

Example

Network data:

- rated voltage 400 V AC
- rated frequency 400 Hz
- load current 240 A (I_b)
- current carrying capacity of cable 260 A (I_z)
- short circuit current 32 kA

To decide which circuit-breaker is suitable for this application, the two fundamental conditions for correct use of the circuit-breaker at 400 Hz must be remembered:

- derating of the thermal protection equal to 10%;
- increase in the magnetic threshold according to the K_m coefficient.

Should the installation be at power frequency (50/60 Hz), a T4N 250 TMA In = 250 circuit-breaker would be adequate, based on the rated load current (240 A) and on the installation short-circuit current.

However, since the circuit-breaker must be sized for an application at 400 Hz, it is necessary to consider the prescriptions listed above and, in particular, the derating of the thermal protection means a maximum adjustment of:

$$I_{1 \max 400 \text{ Hz}} = 250 - \left(\frac{250 \cdot 10}{100} \right) = 225 \text{ A}$$

As can be noted, this value is less than the load current and the circuit-breaker with In = 250 A is not adequate. It is therefore necessary to use a T4N 320 TMA In = 320 circuit-breaker, since by adjusting the thermomagnetic release to the median value (0.85) and considering the derating of 10%, the following magnetic trip threshold is obtained:

$$I_{1 \text{ med } 400 \text{ Hz}} = 0.85 \cdot \left[320 - \left(\frac{320 \cdot 10}{100} \right) \right] \cong 244 \text{ A}$$

This value is higher than the rated load current and lower than the current-carrying capacity of the cable and therefore the circuit-breaker is adequate for 400 Hz application. With regard to the magnetic threshold, an adjustment at the minimum of the settings available is recommended (5 x In for a TMA) so as not to have too high a trip value:

$$I_3 = 5 \cdot I_n \cdot K_m = 5 \cdot 320 \cdot 1.7 = 2720 \text{ A}$$

Special applications

Use of direct current apparatus

Use of direct current apparatus

To obtain the number of poles in series needed to guarantee the required breaking capacity at the various operating voltages, suitable connection diagrams must be used. For the breaking capacity (I_{cu}), according to the voltage and the number of poles connected in series with reference to the connection diagrams, please refer to the table on page 4/58.

Protection and isolation of the circuit with three-pole circuit-breakers

Diagram A: Interruption with one pole for polarity

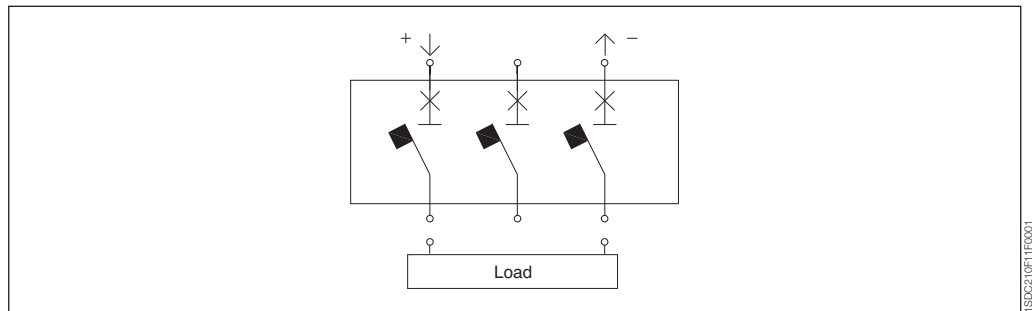

Note: With negative polarity not connected to earth, the installation method must be such as to make the probability of a second earth fault nil.

Diagram B: Interruption with two poles in series for one polarity and one pole for the other polarity

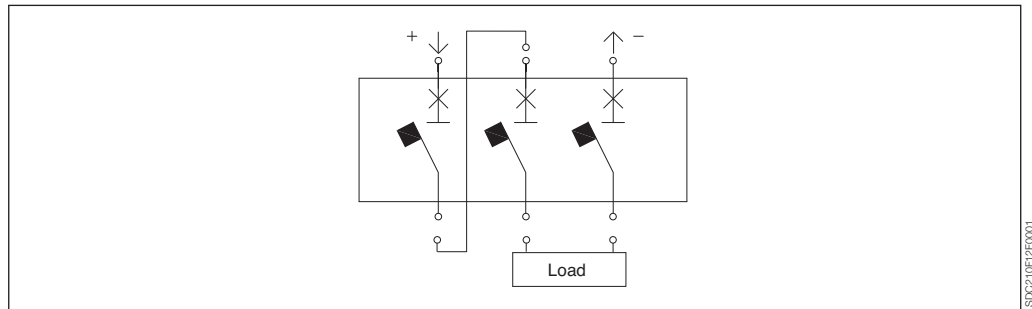

Note: With negative polarity not connected to earth, the installation method must be such as to make the probability of a second earth fault nil.

Diagram C: Interruption with three poles in series for polarity

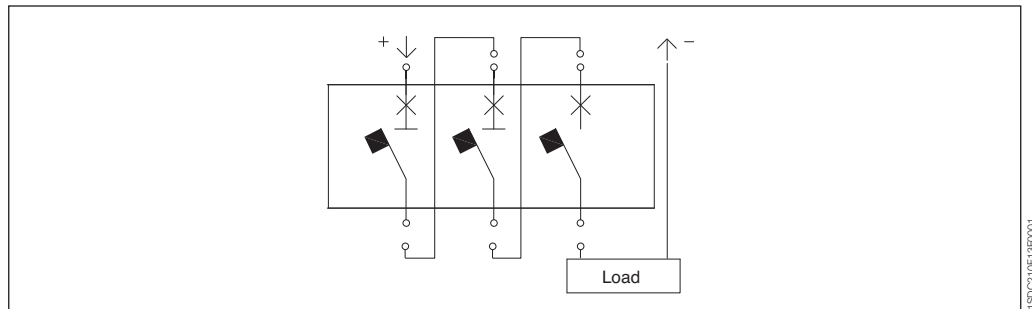

Special applications

Use of direct current apparatus

Diagram D: Interruption with four poles in series for one polarity (for use at 1000 V DC)

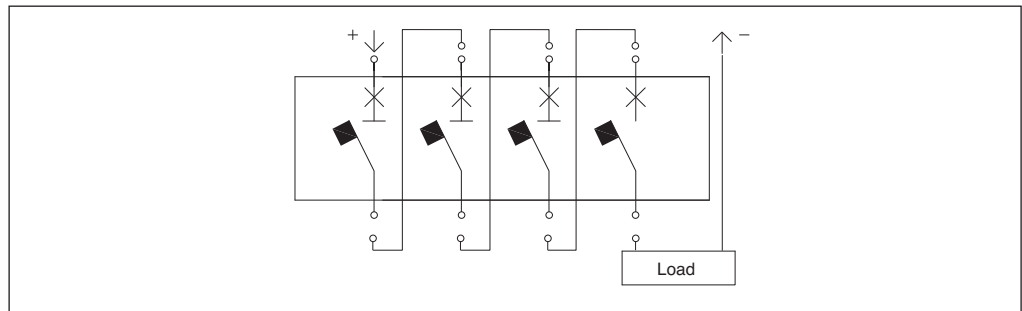

1SDC210F14F0001

Diagram E: Interruption with three poles in series on one polarity and one pole on the remaining polarity

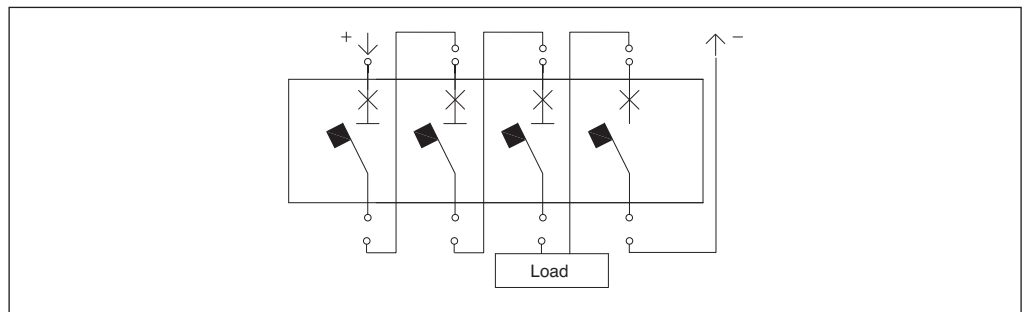

1SDC210F15F0001

Note: With negative polarity not connected to earth, the installation method must be such as to make the probability of a second earth fault nil.

Diagram F: Interruption with two poles in series for polarity

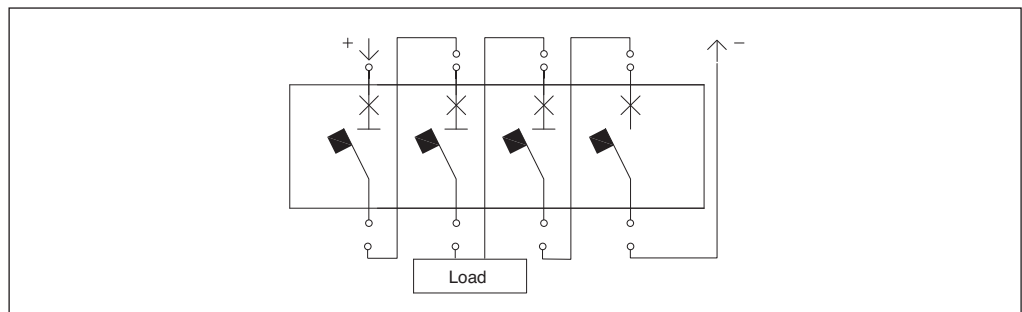

1SDC210F16F0001

Note: With negative polarity not connected to earth, the installation method must be such as to make the probability of a second earth fault nil.

The following table shows which connection diagram to use according to the number of poles to be connected in series to obtain the required breaking capacity, in relation to the type of distribution network:

Distribution system

Voltage	T1-T2-T3	T4-T5-T6	Insulated network ⁽¹⁾	Earthed polarity ⁽²⁾	Earthed midpoint
≤ 250 V DC	■	–	A - B	B - C - E	F ⁽³⁾
	–	■	A	B	F ⁽³⁾
≤ 500 V DC	■	–	B	C - E	F
	–	■	A	B	F ⁽³⁾
≤ 750 V DC	–	■	B	C - E	F
≤ 1000 V DC	–	■	E - F	D	F

¹⁾ The likelihood of a double earth fault is assumed to be nil

²⁾ Assuming a negative (-) earthed polarity

³⁾ Consult ABB on the use of three-pole breakers

General note:

The suitability of the wiring of the poles must be assessed in the light of the short circuit current value and the breaking power specified for the various circuit breakers. The pole connecting methods C and D are used to achieve a protective function, not to disconnect the earthed polarity.

In the following table, the correction value to be used for the protection thresholds against short circuit is indicated for each circuit-breaker (the thermal threshold does not undergo any alteration).

Circuit-breaker	Diagram A	Diagram B	Diagram C	Diagram D	Diagram E	Diagram F
T1	1.3	1	1	–	–	–
T2	1.3	1.15	1.15	–	–	–
T3	1.3	1.15	1.15	–	–	–
T4	1.3	1.15	1.15	1	1	1
T5	1.1	1	1	0.9	0.9	0.9
T6	1.1	1	1	0.9	0.9	0.9

Special applications

Use of direct current apparatus

Example of setting the trip thresholds in DC - Diagram A

Setting In [A]	T1 160		T2 160		T3 250		T4 250	
	$I_1=0.7\div 1xI_n$	$I_3=10xI_n$	$I_1=0.7\div 1xI_n$	$I_3=10xI_n$	$I_1=0.7\div 1xI_n$	$I_3=10xI_n$	$I_1=0.7\div 1xI_n$	$I_3=10xI_n$
1.6			1.12÷1.6	20.8				
2			1.4÷2	26				
2.5			1.75÷2.5	32.5				
3.2			2.24÷3.2	41.6				
4			2.8÷4	52				
5			3.5÷5	65				
6.3			4.41÷6.3	81.9				
8			5.6÷8	104				
10			7÷10	130				
12.5			8.75÷12.5	162.5				
16	11.2÷16	650	11.2÷16	650				
20	14÷20	650	14÷20	650			14÷20	416
25	17.5÷25	650	17.5÷25	650				
32	22.4÷32	650	22.4÷32	650			22.4÷32	416
40	28÷40	650	28÷40	650				
50	35÷50	650	35÷50	650			35÷50	650
63	44.1÷63	819	44.1÷63	819	44.1÷63	819		
80	56÷80	1040	56÷80	1040	56÷80	1040	56÷80	5200÷1040
100	70÷100	1300	70÷100	1300	70÷100	1300	70÷100	650÷1300
125	87.5÷125	1625	87.5÷125	1625	87.5÷125	1625	87.5÷125	812.5÷1625
160	112÷160	2080	112÷160	2080	112÷160	2080	112÷160	1040÷2080
200					140÷200	260	140÷200	1300÷2600
250					175÷250	325	175÷250	1625÷3250

Setting In [A]	T4 320		T5 400		T5 630		T6 630		T6 800	
	$I_1=0.7\div 1xI_n$	$I_3=5\div 10xI_n$	$I_1=0.7\div 1xI_n$	$I_3=5\div 10xI_n$	$I_1=0.7\div 1xI_n$	$I_3=5\div 10xI_n$	$I_1=0.7\div 1xI_n$	$I_3=5\div 10xI_n$	$I_1=0.7\div 1xI_n$	$I_3=5\div 10xI_n$
20	14÷20	416								
25										
32	22.4÷32	416								
40										
50	35÷50	650								
63										
80	56÷80	5200÷1040								
100	70÷100	650÷1300								
125	87.5÷125	812.5÷1625								
160	112÷160	1040÷2080								
200	140÷200	1300÷2600								
250	175÷250	1625÷3250								
320			224÷320	1760÷3520						
400			280÷400	2200÷4400						
500					350÷500	2750÷5500				
630							441÷630	3465÷6930		
800									480÷800	4000÷8000

Setting adjustment of the magnetic threshold

The correction factor takes into consideration the phenomena that, with direct current applications, modifies the tripping value of the protection threshold against short circuit. The value that must be set on the trip unit is therefore the real and wanted trip value divided by the correction factor.

Example

- Service current: $I_b = 550$ A
- Circuit-breaker: T6 630 $I_n = 630$ A
- Desired magnetic protection: $I_3 = 5500$ A
- Magnetic threshold value to be set (according to diagram A):

$$\text{Set: } \frac{I_3}{k_m}$$

therefore, in this specific case, setting of the adjustment value for the magnetic threshold is:

$$\text{Set: } \frac{5500}{1.1} = 5000 \text{ A (roughly equal to } 8 I_n)$$

Special applications

Use of direct current apparatus

The residual current trip units are associated with the circuit-breaker in order to obtain two main functions in a single device:

- protection against overloads and short-circuits;
- protection against indirect contacts (presence of voltage on exposed conductive parts due to loss of insulation).

Besides, they can guarantee an additional protection against the risk of fire deriving from the evolution of small fault or leakage currents which are not detected by the standard protections against overload.

Residual current devices having a rated residual current not exceeding 30 mA are also used as a means for additional protection against direct contact in case of failure of the relevant protective means.

Their logic is based on the detection of the vectorial sum of the line currents through an internal or external toroid.

This sum is zero under service conditions or equal to the earth fault current (I_{Δ}) in case of earth fault. When the trip unit detects a residual current different from zero, it opens the circuit-breaker through an opening solenoid.

As we can see in the picture the protection conductor or the equipotential conductor have to be installed outside the eventual external toroid.

Distribution system (IT, TT, TN)

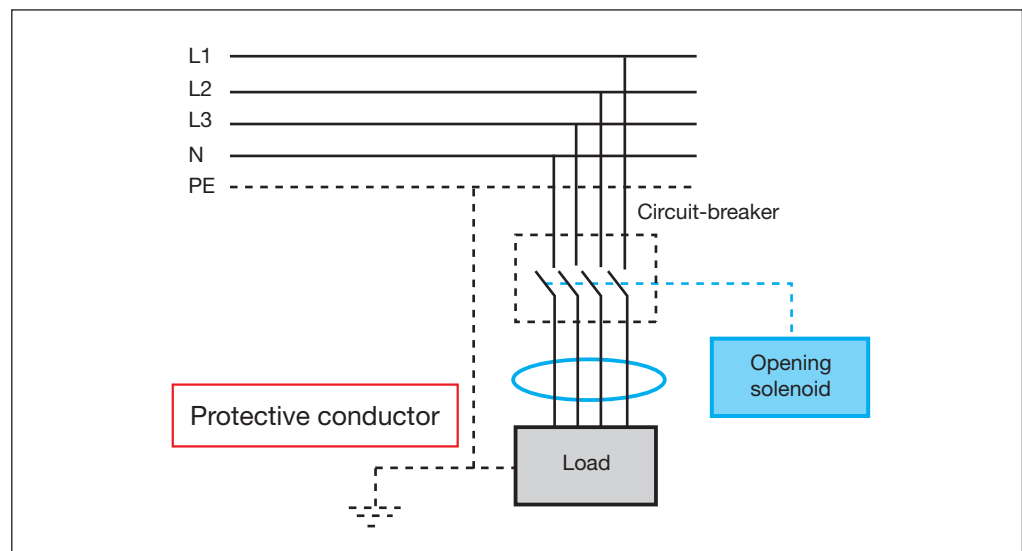

The operating principle of the residual current release makes it suitable for TT, IT distribution systems (although with particular attention to the latter) and TN-S, but not for the TN-C systems. In fact, in these systems the neutral is also used as a protection conductor and therefore determination of the residual current would not be possible even if the neutral, called PEN in these distribution systems, passed through the toroid, since the vectorial sum of the currents would always be equal to zero. One of the main characteristics of a residual current protection is its minimum rated current $I_{\Delta n}$. This represents the sensitivity of the release.

- According to their sensitivity to the fault current the RCDs are classified as:
- type **AC**: the tripping is ensured for residual sinusoidal alternating currents
 - type **A**: the tripping is ensured for residual sinusoidal alternating currents in the presence of specified residual pulsating direct currents
 - type **B**: like the type A and also in presence of residual direct currents

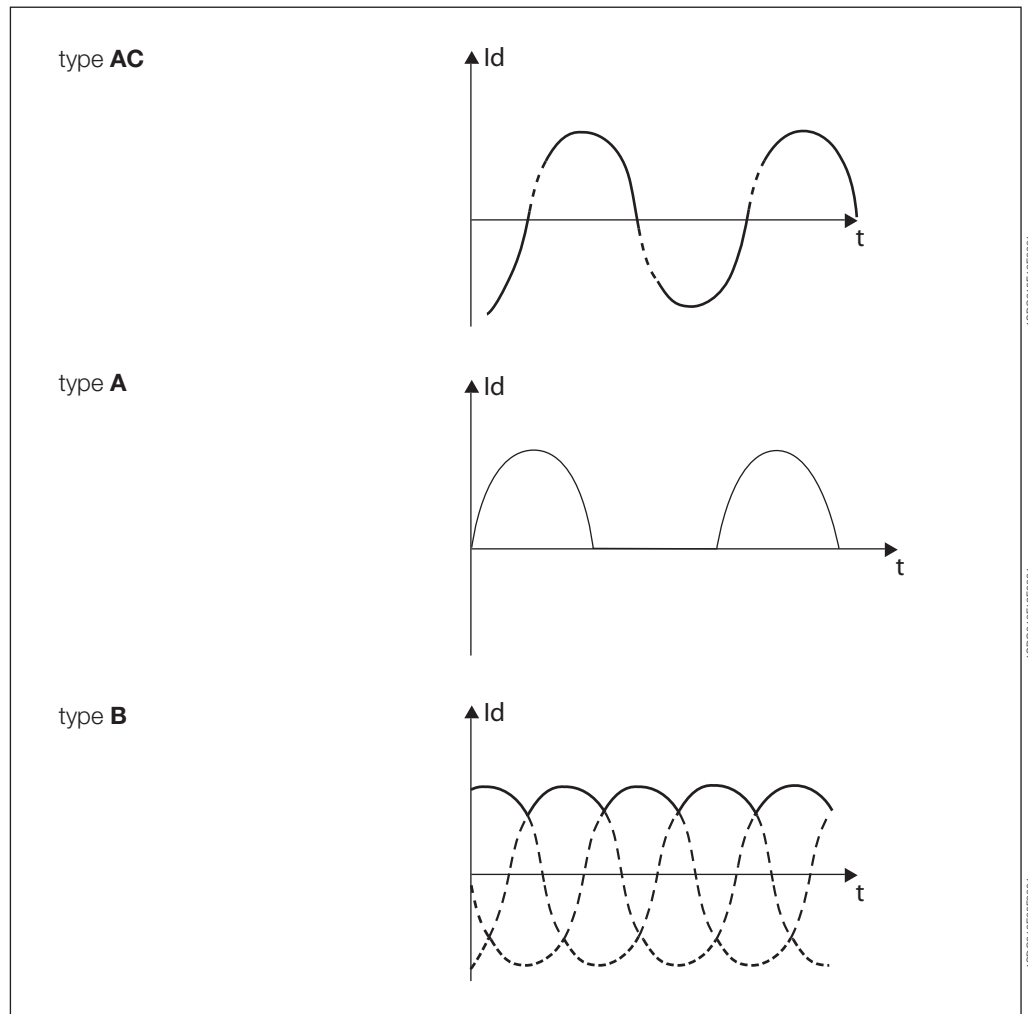

In presence of electrical apparatuses with electronic components (computers, photocopiers, fax etc.) the earth fault current might assume a non sinusoidal shape but a type of a pulsating unidirectional dc shape. In these cases it is necessary to use a residual current trip unit classified as type A. In presence of rectifying circuits (i.e. single phase connection with capacitive load causing smooth direct current, three pulse star connection or six pulse bridge connection, two pulse connection line-to-line) the earth fault current might assume a unidirectional DC shape. In these case it is necessary to use a residual current trip unit classifield as type B.

Special applications

Use of direct current apparatus

Standard EN 50178 "Electronic equipment for use in power installations" shows several examples of electronic circuits where it is correct to use a type B RCD.

A relevant example of the using of the type B RCD RC223 is a network supplying a three-phase bridge rectifier:

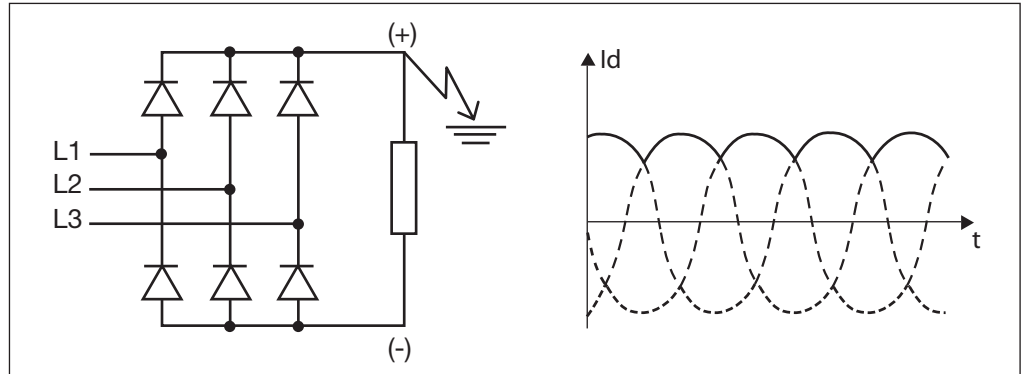

In fact, in the case of an earth fault occurring in the plant section with direct current supply, a fault current with marked "direct" characteristics shall practically flow through the section with alternate current.

The RCD, both A as well as AC type, could be not sensitive to this current and, consequently, not able to trip the circuit by disconnecting the fault.

On the contrary, the type B RCD results to be suitable to detect the residual currents with continuous components and thus able to interrupt the circuit in case of earth fault.

The following table shows the main characteristics of ABB SACE residual current devices; they can be mounted both on circuit-breakers as well as on switch disconnectors (in case of fault currents to earth lower than the apparatus breaking capacity), are type A devices and they do not need auxiliary supply since they are self-supplied.

4

	RC221		RC222		RC223
Suitable for circuit-breaker type/switch-disconnectors	T1-T2-T3 T1D-T3D	T1-T2-T3 T1D-T3D	T4 T4D	T5 T5D	T4 T4D
Primary service voltage [V]	85-500	85-500	85-500	85-500	110...500
Rated service current [A]	250	250	250	250	250
Rated residual current trip $I_{\Delta n}$ [A]	0.03-0.1-0.3-0.5-1-3	0.03-0.05-0.1-0.3-0.5-1-3-5-10	0.03-0.05-0.1-0.3-0.5-1-3-5-10	0.03-0.05-0.1-0.3-0.5-1-3-5-10	0.03-0.05-0.1-0.3-0.5-1
Time limit for non-trip (s)	instantaneous	inst. -0.1-0.2-0.3-0.5-1-2-3	inst. -0.1-0.2-0.3-0.5-1-2-3	inst. -0.1-0.2-0.3-0.5-1-2-3	inst. -0.1-0.2-0.3-0.5-1-2-3
Tolerance over trip times [%]		±20%	±20%	±20%	±20%

Tmax T7 can be equipped with a toroid fitted on the back of the circuit-breaker so as to ensure protection against earth faults. In particular, the electronic trip unit types able to perform this function are:

- PR332/P-LSIG
- PR332/P-LSIRc

Furthermore ABB SACE moulded-case circuit-breakers serie Tmax can be combined with the switchboard residual current relay type RCQ, type A, with separate toroid (to be installed externally on the line conductors).

			RCQ
Power supply voltage	AC	[V]	80-500
	DC	[V]	48-125
Trip threshold adjustments $I\Delta n$			
	1st range of adjustments	[A]	0.03-0.05-0.1-0.3-0.5
	2st range of adjustments	[A]	1-3-5-10-30
Trip time adjustment		[s]	0-0.1-0.2-0.3-0.5-0.7-1-2-3-5
Tolerance over trip times		[%]	±20%

The versions with adjustable trip times allow to obtain a residual current protection system coordinated from a discrimination point of view, from the main switchboard up to the ultimate load.

Special applications

Zone selectivity

This type of coordination, a development of time coordination, is made by means of logic connections between current measuring devices which, once the set threshold having been exceeded is detected, allow just the fault area to be identified and to have its power supply cut off. By means of zone selectivity it is possible obtain selectivity considerably reducing the trip times and therefore the thermal stresses all the plant components are subjected to during the fault.

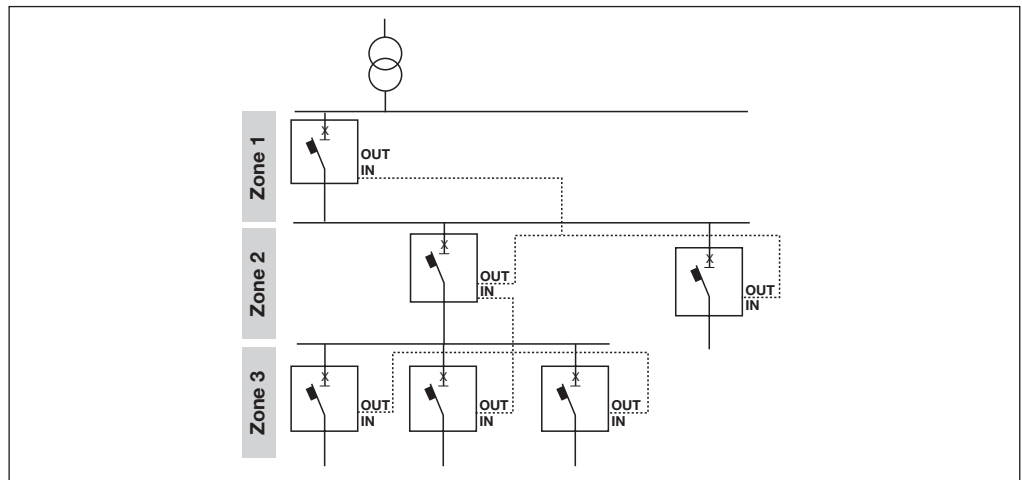

EFDP Zone selectivity (T4L-T5L-T6L with PR223EF)

By means of the new PR223EF electronic trip unit, it is possible to realise EFDP zone selectivity between moulded-case circuit-breakers of the Tmax T4L, T5L and T6L series, obtaining total selectivity between these circuit-breakers.

The PR223EF implements the new EF protection function, capable of detecting the short-circuit at its onset. This is thanks to “predicting” the fault, based on analysis of the trend of the current derivative in relation to the time, $di(t)/dt$ vs $i(t)$.

If the EF protection is enabled, it intervenes for faults of considerable size, replacing the I protection function against instantaneous short-circuit when there is an auxiliary power supply.

Between PR223EF trip units, EFDP zone selectivity is implemented simultaneously on functions S, G and EF. It is carried out by means of an interlocking protocol (Interlocking, IL), guaranteed by a couple of shielded twisted pair cables for modbus RS485 which connect the circuit-breakers equipped with the PR223EF (ask ABB for further information about cable type).

In the case of a short-circuit, the circuit-breaker immediately to the supply side sends a lock signal to the hierarchically higher level protection by means of the bus and, before tripping, checks that a similar lock signal has not come from the load-side protection.

System integrity is controlled by a monitoring function: in the case of a short-circuit, if a fault is found in the interlocking system, the EF protection function trips (with trip times in the order of tens of ms), but zone selectivity is not guaranteed.

Furthermore, if the load-side circuit-breaker does not manage to trip, it asks the supply-side circuit-breaker for help and the latter opens even if it does not detect the fault (SOS function).

A 24 V DC auxiliary power supply is required for operation of the EF protection and zone selectivity. All the protection functions can be programmed remotely, exploiting the dialogue function on the trip unit, or locally by means of the PR010/T, which can be connected to a serial port on the front of the PR223EF.

One of the main advantages in using zone selectivity between MCCBs is the reduction in size of the circuit-breakers it makes possible.

In fact, in looking for selectivity between moulded-case circuit-breakers with the classic techniques, it is often necessary to increase the size of the supply-side circuit-breakers to obtain selectivity limits congruous with the short-circuit current of the installation.

By means of suitably cabled PR223EF releases, it is possible to obtain total selectivity even between two circuit-breakers of the same size.

An example is given below of how, by means of zone selectivity between moulded-case circuit-breakers, a reduction in sizes and a considerable reduction in the peak current and specific energy let through by the circuit-breakers is possible, whilst still maintaining total selectivity.

The main parameters, characteristic of the trip unit, are:

- Trip delayed** Enabling this parameter introduces a trip delay in the case when, on the load side of a trip unit, Tmax or modular circuit-breakers are installed. The aim of this parameter is to obtain selectivity with the other devices on the load side not equipped with PR223EF. This parameter is only enabled in the circuit-breakers which have the device outside the zone selectivity chain on the load side.
- EF enable/disable** Enabling/disabling protection EF.
If protection EF is enabled: the presence of Vaux leads to automatic exclusion of function I and enabling of protection EF, the lack of Vaux leads to exclusion of protection EF and to the return of function I (if enabled).
- 16** Maximum number of trip units which can be connected to the BUS of a level.
- 1 kilometer** Maximum overall length of the connection cable. Cabling the different trip units is carried out as in the classic "Bus topology" (see figure)

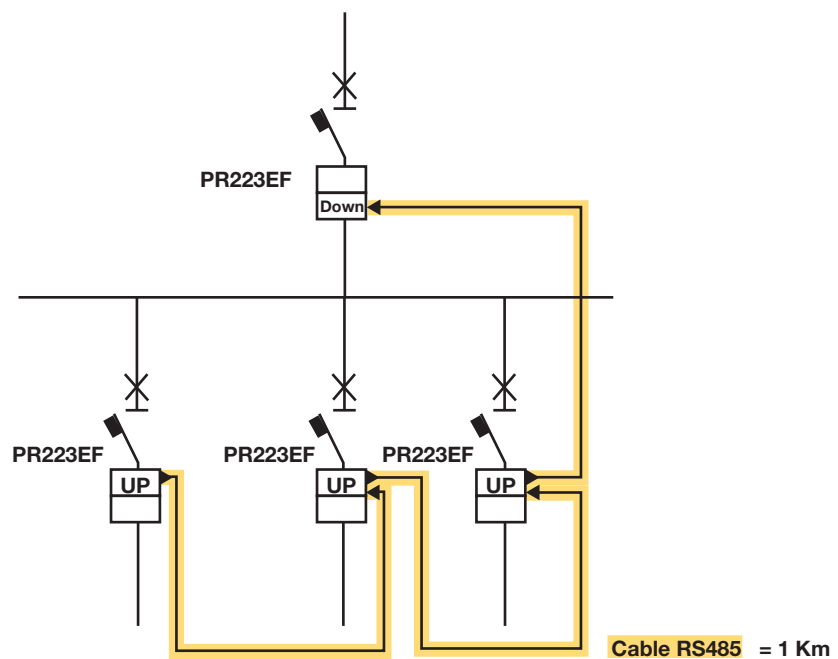

Special applications

Zone selectivity

Example of application

The following example shows an installation where selectivity is obtained through EFDP system available on PR223EF. Besides, in brackets, the circuit-breakers to obtain selectivity with the traditional solution are reported.

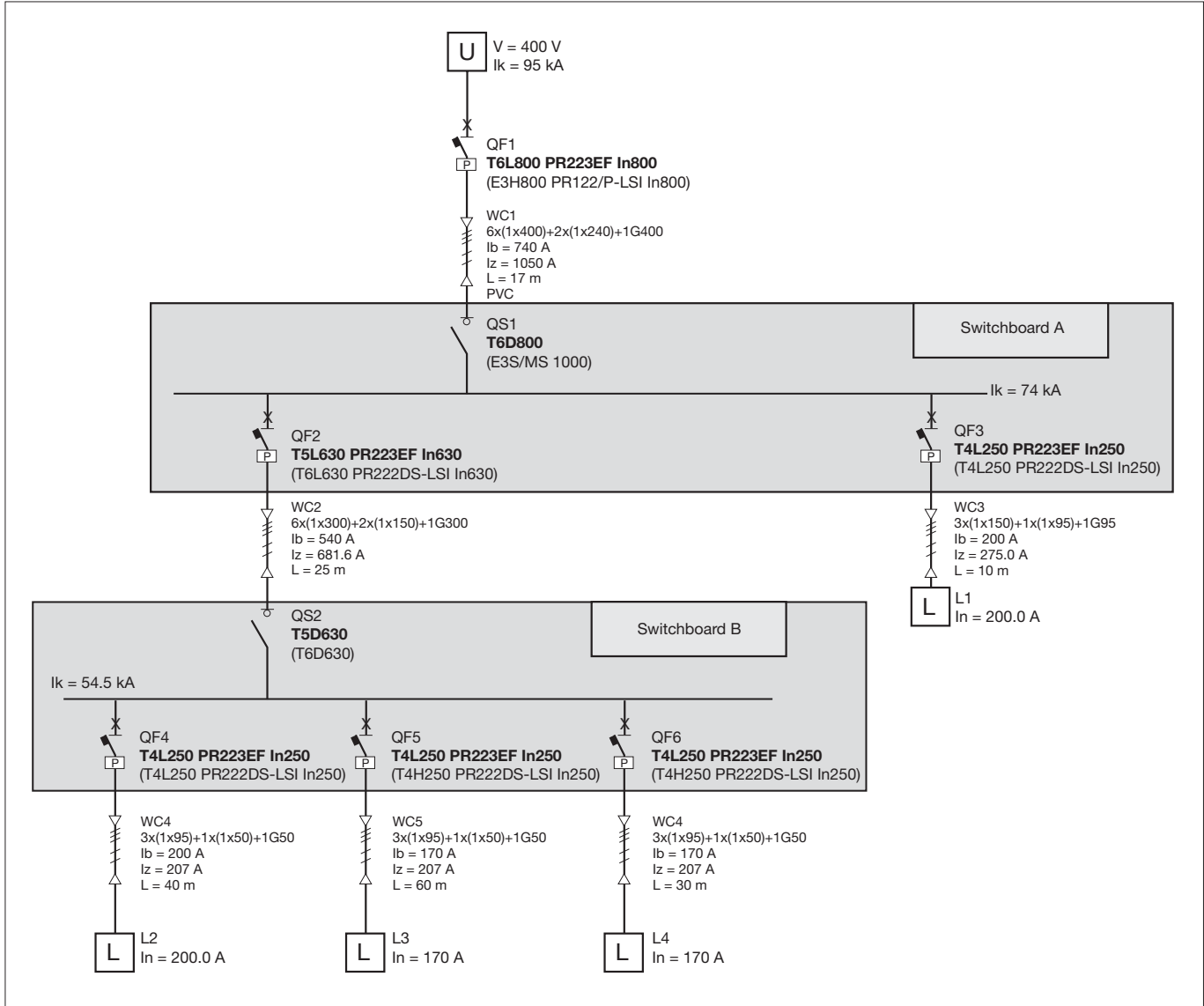

It is evident that selectivity through the traditional techniques affects deeply the choice of the protection devices and direct it towards differentiated sizes according to the location of the circuit-breakers in the installation.

The following table summarizes the advantages from a dimensional and economical point of view which derive from the use of the new electronic trip unit.

	Traditional solution	Solution with EFDP
QF1	E3H800 PR122/P	T6L800 PR223EF
QS1	E3S/MS1000	T6D800
QF2	T6L630 PR221DS	T5L630 PR223EF
QS2	T6D630	T5D630

Index

Information for reading - Circuit-breakers T1...T6.....	5/2
Information for reading - Circuit-breakers T7.....	5/6
Information for reading - ATS010 for T4-T5-T6.....	5/10
Information for reading - ATS010 for T7.....	5/11
Graphic symbols (IEC 60617 and CEI 3-14...3-26 Standards).....	5/12
Wiring diagram of the T1...T6 circuit-breakers.....	5/13
Wiring diagram of the T7 circuit-breakers.....	5/15
Electrical accessories for T1...T6.....	5/17
Electrical accessories for T7.....	5/26
Automatic transfer-switch ATS010 for T4-T5-T6.....	5/30
Automatic transfer-switch ATS010 for T7.....	5/34

Wiring diagrams

Information for reading - Circuit-breakers T1...T6

State of operation represented

The diagram is shown in the following conditions:

- plug-in version circuit-breaker open and racked-in
- contactor for motor starting open
- circuits de-energised
- trip units not tripped
- motor operator with springs charged.

Version

The diagram shows a circuit-breaker or switch-disconnector in the plug-in version (only T2, T3, T4 and T5) or in the withdrawable version (T6). The diagram is also valid for the fixed and withdrawable version circuit-breakers or switch-disconnectors.

With the fixed version circuit-breakers or switch-disconnectors, the applications indicated in figures 26-27-28-29-30-31 and 32 cannot be provided.

Caption

□	= Figure number of the diagram
*	= See note indicated by the letter
A1	= Circuit-breaker applications
A11	= FDU interfacing unit (front display)
A12	= AUX-E type signalling unit, with auxiliary relays for electrical signalling of circuit-breaker open and circuit-breaker tripped
A13	= PR021/K type signalling unit, with auxiliary relays for electrical signalling of the protection functions of electronic trip unit
A14	= MOE-E type actuation unit, with auxiliary relays for carrying out the commands coming from the dialogue unit
A15	= PR212/CI type contactor control unit for motor starting
A16	= Solenoid operating mechanism
A17	= Unit for M motor electrical latching
A18	= VM210 type voltage measuring unit
A2	= Applications of the solenoid operator or motor operator
A3	= Applications of the RC221, RC222 or RC223 type residual current release
A4	= Indication apparatus and connections for control and signalling, outside the circuit-breaker
D	= Electronic time-delay device of the undervoltage release (outside the circuit-breaker)
H, H1	= Signalling lamps
K	= Contactor for motor starting
K51	= Electronic trip unit: <ul style="list-style-type: none">- PR221 type overcurrent release, with the following protection functions:<ul style="list-style-type: none">- L against overload with inverse long time delay- S against short-circuit with inverse or definite short time delay- I against short-circuit with instantaneous trip- PR222DS/P, PR222DS/PD, PR223DS or PR223EF, type overcurrent release, with the following protection functions:<ul style="list-style-type: none">- L against overload with inverse long time delay- S against short-circuit with inverse or definite short time delay- I against short-circuit with instantaneous trip time- G against earth fault with short time trip- EFDP protection (Earth Fault Detector Prevention) for PR223EF trip unit only- PR222MP motor protection type trip unit, with the following protection functions:<ul style="list-style-type: none">- against overload (thermal protection)- against rotor block- against short-circuit- against missing or unbalanced current between the phases
K51/1...8	= Contact for electrical signalling of the protection functions of the electronic trip unit
K87	= RC221, RC222 or RC223 type residual current trip unit
M	= Motor for circuit-breaker opening and circuit-breaker closing spring charging
M1	= Three-phase asynchronous motor
Q	= Main circuit-breaker
Q/0,1,2,3	= Auxiliary circuit-breaker contacts

R	= Resistor (see note F)
R1	= Motor thermistor
R2	= Thermistor in the motor operator
S1, S2	= Contacts controlled by the cam of the motor operator
S3, S3/1	= Change-over contact for electrical signalling of local/remote selector status
S4/1-2	= Contacts activated by the circuit-breaker rotary handle (see note C)
S51/S	= Contact for electrical signalling of overload in progress (start)
S75I/1...3	= Contacts for electrical signalling of circuit-breaker in racked-in position (only provided with circuit-breakers in plug-in and withdrawable version)
S75S/1...3	= Contacts for electrical signalling of circuit-breaker in racked-out position (only provided with circuit-breakers in plug-in and withdrawable version)
S87/1	= Contact for electrical signalling of RC222 or RC223 type residual current release pre-alarm
S87/2	= Contact for electrical signalling of RC222 Change-over contact for electrical signalling of local/remote selector status type residual current release alarm
S87/3	= Contact for electrical signalling of circuit-breaker open due to RC221, RC222 or RC223 type residual current release trip
SC	= Pushbutton or contact for closing the circuit-breaker
SC3	= Pushbutton for motor starting
SD	= Switch-disconnector of the power supply of the RC221 or RC222 type residual current release
SO	= Pushbutton or contact for opening the circuit-breaker
SO1, SO2	= Pushbuttons or contacts for the circuit-breaker opening (see Resetting instructions for circuit-breaker tripped by trip units)
SO3	= Pushbutton for stopping the motor
SQ	= Contact for electrical signalling of circuit-breaker open
SY	= Contact for electrical signalling of circuit-breaker open due to YO, YO1, YO2 or YU thermomagnetic trip unit intervention (tripped position)
TI	= Toroidal current transformer
TI/L1	= Current transformer placed on phase L1
TI/L2	= Current transformer placed on phase L2
TI/L3	= Current transformer placed on phase L3
TI/N	= Current transformer placed on the neutral
W1	= Serial interface with the control system (EIA RS485 interface. See note D)
W2	= Interface to upstream circuit-breaker for zone selectivity interlocking (for PR223EF trip unit only)
W3	= Interface to downstream circuit-breaker for zone selectivity interlocking (for PR223EF trip unit only)
X1,X2,X5...X9	= Connectors for the circuit-breaker auxiliary circuits (in the case of circuit-breakers in plug-in version, removal of the connectors takes place simultaneously with that of the circuit-breaker. See note E)
X11	= Back-up terminal box
X3,X4	= Connectors for the circuits of the electronic trip unit (in the case of circuit-breakers in the plug-in version, removal of the connectors takes place simultaneously with that of the circuit-breaker)
XA	= Interfacing connector of the PR222DS/P, PR222DS/PD, PR223DS or PR223EF trip unit
XA1	= Three-way connector for YO/YU (see note E)
XA10	= Six-way connector for solenoid operator
XA2	= Twelve-way connector for auxiliary contacts (see note E)
XA5	= Three-way connector for contact of electrical signalling of circuit-breaker open due to trip of the RC221, RC222 or RC223 type residual current release (see note E)
XA6	= Three-way connector for contact of electrical signalling of circuit-breaker open due to trip of the overcurrent release (see note E)
XA7	= Six-way connector for auxiliary contacts (see note E)
XA8	= Six-way connector for contacts operated by the rotary handle or for the motor operator (see note E)
XA9	= Six-way connector for the electrical signalling of RC222 or RC223 type residual current release pre-alarm and alarm and for opening by means of the release itself (see note E)
XB,XC,XE	= Interfacing connectors of the AUX-E unit
XD	= Interfacing connector of the FDU unit

Wiring diagrams

Information for reading - Circuit-breakers T1...T6

XF	= Interfacing connector of the MOE-E unit
XO	= Connector for the YO1 trip coil
XO1	= Connector for the YO2 trip coil
XV	= Terminal boxes of the applications
YC	= Closing release of the motor operating mechanism
YO	= Opening release
YO1	= Trip coil of the electronic trip unit
YO2	= Trip coil of the RC221, RC222 or RC223 type residual current release
YO3	= Shunt opening release of the solenoid operator
YU	= Undervoltage release (see note B).

Description of figures

- Fig. 1 = Opening release.
- Fig. 2 = Permanent opening release.
- Fig. 3 = Instantaneous undervoltage release (see note B and F).
- Fig. 4 = Undervoltage release with electronic time-delay device outside the circuit-breaker (see note B).
- Fig. 5 = Instantaneous undervoltage release in version for machine tools with one contact in series (see note B, C, and F).
- Fig. 6 = Instantaneous undervoltage release in version for machine tools with two contacts in series (see note B, C, and F).
- Fig. 7 = One changeover contact for electrical signalling of circuit-breaker open due to RC221, RC222 or RC223 type residual current release trip.
- Fig. 8 = RC222 or RC223 type residual current release circuits.
- Fig. 9 = Two electrical signalling contacts for RC222 or RC223 type residual current release pre-alarm and alarm.
- Fig. 10 = Solenoid operator.
- Fig. 11 = Stored energy motor operator.
- Fig. 12 = Local/remote auxiliary contact for stored-energy motor operating mechanism.
- Fig. 21 = Three changeover contacts for electrical signalling of circuit-breaker open or closed and one changeover contact for electrical signalling of circuit-breaker open due to YO, YO1, YO2 and YU thermomagnetic trip unit intervention (tripped position).
- Fig. 22 = One changeover contact for electrical signalling of circuit-breaker open or closed and a changeover contact for electrical signalling of circuit-breaker open due to YO, YO1, YO2 or YU the thermomagnetic trip unit intervention (tripped position).
- Fig. 23 = Two changeover contacts for electrical signalling of circuit-breaker open or closed.
- Fig. 24 = One changeover contact for electrical signalling of circuit-breaker open due to overcurrent release trip (T2).
- Fig. 25 = One contact for electrical signalling of circuit-breaker open due to overcurrent release trip (T4-T5-T6).
- Fig. 26 = First position of circuit-breaker changeover contact, for electrical signalling of racked-in.
- Fig. 27 = Second position of circuit-breaker changeover contact, for electrical signalling of racked-in.
- Fig. 28 = Third position of circuit-breaker changeover contact, for electrical signalling of racked-in.
- Fig. 29 = First position of circuit-breaker changeover contact, for electrical signalling of isolated.
- Fig. 30 = Second position of circuit-breaker changeover contact, for electrical signalling of isolated.
- Fig. 31 = Third position of circuit-breaker changeover contact, for electrical signalling of isolated.
- Fig. 32 = Circuit of the current transformer on neutral conductor outside the circuit-breaker (for plug-in and withdrawable version circuit-breaker).
- Fig. 39 = Auxiliary circuits of the PR223DS trip units connected to VM210 voltage measuring unit.
- Fig. 40 = Auxiliary circuits of the PR223EF trip units connected to VM210 voltage measuring unit.
- Fig. 41 = Auxiliary circuits of the PR222DS/P, PR222DS/PD, PR223DS or PR223EF electronic trip unit connected with FDU front display unit.
- Fig. 42 = Auxiliary circuits of the PR222DS/PD, PR223DS or PR223EF electronic trip unit connected with PR021/K type signalling unit.
- Fig. 43 = Auxiliary circuits of the PR222DS/PD, PR223DS or PR223EF electronic trip unit connected with FDU front display unit and with PR021/K type signalling unit.
- Fig. 44 = Auxiliary circuits of the PR222DS/PD, PR223DS or PR223EF electronic trip unit connected with the AUX-E auxiliary contacts.
- Fig. 45 = Auxiliary circuits of the PR222DS/PD, PR223DS or PR223EF electronic trip unit connected with the auxiliary contacts AUX-E and with MOE-E type actuation unit.
- Fig. 46 = Auxiliary circuits of the PR222DS/PD, PR223DS or PR223EF electronic trip unit connected with FDU front display unit and with the AUX-E auxiliary contacts.

- Fig. 47 = Auxiliary circuits of the PR222MP electronic trip unit connected with PR021/K signalling unit (see note I).
- Fig. 48 = Auxiliary circuits of the PR222MP electronic trip unit connected with PR021/K signalling unit and with PR212/CI type contactor control unit for motor starting (see note I).
- Fig. 49 = Auxiliary circuits of the PR222MP electronic trip unit connected with PR021/K signalling unit and with PR212/CI type contactor control unit and an ABB series AF contactor (see note I).
- Fig. 51 = Auxiliary circuit of the PR222MP trip unit connected to SACE PR212/CI motor starting contactor control unit and 24 V DC auxiliary supply (see note I).

Incompatibility

The circuits indicated by the following figures cannot be supplied at the same time on the same circuit-breaker:

1 - 2 - 3 - 4 - 5 - 6

5 - 6 - 11

10 - 11 - 45

10 - 12

21 - 22 - 23 - 44 - 45 - 46

24 - 25

26 - 32

39 - 40 - 41 - 42 - 43 - 44 - 45 - 46 - 47 - 48 - 49 - 50 - 51

Notes

- A) The circuit-breaker is only fitted with the applications specified in the ABB SACE order confirmation. To make out the order, please consult this catalogue.
- B) The undervoltage release is supplied for power supply branched on the supply side of the circuit-breaker or from an independent source: circuit-breaker closing is only allowed with the release energised (the lock on closing is made mechanically).
- C) The S4/1 and S4/2 contacts shown in figures 5-6 open the circuit with the circuit-breaker open and close it again when a manual closing command is given by means of the rotary handle, in accordance with the Standards regarding machine tools (in any case, closing does not take place if the undervoltage release is not supplied).
- E) Connectors XA1, XA2, XA5, XA6, XA7, XA8 and XA9 are supplied on request. They are always supplied with T2 and T3 circuit-breakers in the plug-in version, and with T4 and T5 circuit-breakers in the plug-in version equipped with unwired electronic accessories. Connectors X1, X2, X5, X6, X7, X8 and X9 are supplied on request. They are always supplied with T4, T5 and T6 circuit-breakers in the fixed version or in the withdrawable version equipped with unwired electronic accessories.
- F) Additional external resistor for undervoltage release supplied at 250 V DC, 380/440 V AC and 480/500 V AC.
- G) In the case of fixed version circuit-breaker with current transformer on external neutral conductor outside the circuit-breaker, when the circuit-breaker is to be removed, it is necessary to short-circuit the terminals of the TI/N transformer.
- H) SQ and SY contacts of AUX-E signalling unit are opto-isolated contacts.
- I) The connection to poles 3-4 of X4 connector can be used in two ways: connecting a generic digital input or connecting the motor thermistor. The two functions are alternative.

Wiring diagrams

Information for reading - Circuit-breakers T7

Warning

Before installing the circuit-breaker, carefully read notes F and O on the circuit diagrams.

Operating status shown

The circuit diagram is for the following conditions:

- withdrawable circuit-breaker, open and racked-in
- circuits de-energised
- releases not tripped
- motor operating mechanism with springs discharged.

Versions

Though the diagram shows a circuit-breaker in withdrawable version, it can be applied to a fixed version circuit-breaker as well.

Fixed version

The control circuits are fitted between terminals XV (connectors X12-X13-X14-X15 are not supplied). With this version, the applications indicated in figure 31A cannot be provided.

Withdrawable version

The control circuits are fitted between the poles of connectors X12-X13-X14-X15 (terminal box XV is not supplied).

Version without overcurrent release

With this version, the applications indicated in figures 13A, 14A, 41A, 42A, 43A, 44A, 45A, 62A cannot be provided.

Version with PR231/P or PR232/P electronic trip unit

With this version, the applications indicated in figures 41A, 42A, 43A, 44A, 45A, 62A cannot be provided.

Version with PR331/P electronic trip unit

With this version, the applications indicated in figures 42A, 43A, 44A, 45A cannot be provided.

Version with PR332/P electronic trip unit

With this version, the applications indicated in figure 41A cannot be provided.

Caption

□	= Circuit diagram figure number
*	= See note indicated by letter
A1	= Circuit-breaker accessories
A3	= Accessories applied to the fixed part of the circuit-breaker (for withdrawable version only)
A4	= Example switchgear and connections for control and signalling, outside the circuit-breaker
A13	= PR021/K signalling unit (outside the circuit-breaker)
A19	= PR330/R actuation unit
AY	= SOR TEST UNIT Test/monitoring Unit (see note R)
D	= Electronic time-delay device of the undervoltage release, outside the circuit-breaker
K51	= PR231/P, PR232/P, PR331/P, PR332/P type electronic trip unit with the following protection functions: <ul style="list-style-type: none">- L overload protection with inverse long time-delay trip - setting I_1- S short-circuit protection with inverse or definite short time-delay trip - setting I_2- I short-circuit protection with instantaneous time-delay trip - setting I_3- G earth fault protection with inverse short time-delay trip - setting I_4
K51/1...8	= Contacts of the PR021/K signalling unit
K51/GZin (DBin)	= Zone selectivity: input for protection G or "reverse" direction input for protection D (only with Uaux. and PR332/P trip unit)
K51/GZout (DBout)	= Zone selectivity: output for protection G or "reverse" direction output for protection D (only with and PR332/P trip unit)
K51/SZin (DFin)	= Zone selectivity: input for protection S or "direct" input for protection D (only with Uaux. and PR332/P trip unit)

K51/SZout (DFout)	= Zone selectivity: output for protection S or “direct” output for protection D (only with Uaux. and PR332/P trip unit)
K51/YC	= Closing control from PR332/P electronic trip unit with communication module PR330/D-M and PR330/R actuation unit
K51/YO	= Opening control from PR332/P electronic trip unit with communication module PR330/D-M and PR330/R actuation unit
M	= Motor for charging the closing springs
Q	= Circuit-breaker
Q/1...6	= Circuit-breaker auxiliary contacts
S33M/1...3	= Limit contacts for spring-charging motor
S4/1-2-3	= Contacts activated by the rotary handle of the circuit-breaker – only for circuit-breakers with manual control (see note C)
S43	= Switch for setting remote/local control
S51	= Contact for electrical signalling of circuit-breaker open due to tripping of the overcurrent trip unit. The circuit-breaker may be closed only after pressing the reset pushbutton, or after energizing the coil for electrical reset (if available)
S51/P1	= Programmable contact (as default it signals overload present - start)
S75E/1...2	= Contacts for electrical signalling of circuit-breaker in racked-out position (only with withdrawable circuit-breakers)
S75I/1...7	= Contacts for electrical signalling of circuit-breaker in racked-in position (only with withdrawable circuit-breakers)
S75T/1..2	= Contacts for electrical signalling of circuit-breaker in test isolated position (only with withdrawable circuit-breakers)
SC	= Pushbutton or contact for closing the circuit-breaker
SO	= Pushbutton or contact for opening the circuit-breaker
SO1	= Pushbutton or contact for opening the circuit-breaker with delayed trip
SO2	= Pushbutton or contact for opening the circuit-breaker with instantaneous trip
SR	= Pushbutton or contact for electrical circuit-breaker reset
SRTC	= Contact for electrical signalling of circuit-breaker open, with springs charged and ready to close
SY	= Contact for electrical signalling of circuit-breaker open due to trip units tripped, YO, YO1, YO2, YU (tripped position) only for circuit-breakers with direct control
TI/L1	= Current transformer located on phase L1
TI/L2	= Current transformer located on phase L2
TI/L3	= Current transformer located on phase L3
T0	= Homopolar Toroidal current transformer (see note T)
TU	= Insulating voltage transformer
Uaux.	= Auxiliary power supply voltage (see note F)
UI/L1	= Current sensor (Rogowski coil) located on phase L1
UI/L2	= Current sensor (Rogowski coil) located on phase L2
UI/L3	= Current sensor (Rogowski coil) located on phase L3
UI/N	= Current sensor (Rogowski coil) located on neutral
UI/0	= Current sensor (Rogowski coil) located on the conductor connecting to earth the star point of the MV/LV transformer (see note G)
W1	= Serial interface with control system (external bus): EIA RS485 interface (see note E)
W2	= Serial interface with the accessories of PR331/P and PR332/P trip units (internal bus)
X12...X15	= Delivery connectors for auxiliary circuits of withdrawable version circuit-breaker
XB1...XB7	= Connectors for the accessories of the circuit-breaker
XF	= Delivery terminal box for the position contacts of the withdrawable circuit-breaker (located on the fixed part of the circuit-breaker)
XO	= Connector for YO1 release
XR1 – XR2	= Connector for power circuits of PR231/P, PR232/P, PR331/P, and PR332/P trip units
XR5 – XR13	= Connector for power circuits of PR332/P trip unit
XV	= Delivery terminal box for the auxiliary circuits of the fixed circuit-breaker
XK5	= Connectors for the auxiliary circuits of the PR332 trip unit
YC	= Shunt closing release
YO	= Shunt opening release
YO1	= Overcurrent shunt opening release (trip coil)
YO2	= Second shunt opening release (see note Q)
YR	= Coil to electrically reset the circuit-breaker
YU	= Undervoltage release (see notes B, C and Q)

Wiring diagrams

Information for reading - Circuit-breakers T7

Description of figures

- Fig. 1A = Motor circuit to charge the closing springs.
- Fig. 2A = Circuit of shunt closing release.
- Fig. 4A = Shunt opening release.
- Fig. 6A = Instantaneous undervoltage release (see notes B, C and Q).
- Fig. 7A = Undervoltage release with electronic time-delay device, outside the circuit-breaker (see notes B and Q).
- Fig. 8A = Second shunt opening release (see note Q).
- Fig. 11A = Contact for electrical signalling of springs charged or discharged.
- Fig. 12A = Contact for electrical signalling of circuit-breaker open, with springs charged, and ready to close.
- Fig. 13A = Contact for electrical signalling of circuit-breaker open due to tripping of the overcurrent release. The circuit-breaker may be closed only after pressing the reset pushbutton, or after energizing the coil for electronic reset (if available).
- Fig. 14A = Electrical reset control.
- Fig. 15A = Contact operated by the circuit-breaker rotary handle – for circuit-breakers with manual control only (see note C).
- Fig. 21A = Circuit-breaker auxiliary contacts (for circuit-breakers with manual control only).
- Fig. 22A = Circuit-breaker auxiliary contacts (for circuit-breakers with motor control only).
- Fig. 31A = First set of contacts for electrical signalling of circuit-breaker in racked-in, test isolated, racked out position.
- Fig. 41A = Auxiliary circuits of PR331/P trip unit (see note F).
- Fig. 42A = Auxiliary circuits of PR332/P trip units (see notes F and N).
- Fig. 43A = Circuits of the measuring module PR330/V of the PR332/P trip units internally connected to the circuit-breaker (optional).
- Fig. 44A = Circuits of the measuring module PR330/V of the PR332/P trip units externally connected to the circuit-breaker (optional; see note O).
- Fig. 45A = Circuits of the PR332/P trip unit with communication module PR330/D-M connected to PR330/V actuation unit (see notes E, F and N).
- Fig. 46A = Circuits of the PR332/P trip unit PR330/V measuring module connected internally to the three-pole circuit-breaker with external neutral conductor (optional)
- Fig. 61A = SOR TEST UNIT Test/monitoring unit (see note R).
- Fig. 62A = Circuits of the PR021/K signalling module (outside the circuit-breaker).

Incompatibilities

The circuits indicated in the following figures cannot be supplied simultaneously on the same circuit-breaker:

- 6A - 7A - 8A
- 21A - 22A
- 41A - 42A - 45A
- 43A - 44A - 46A

Notes

- A) The circuit-breaker is only fitted with the applications specified in the ABB SACE order confirmation. To make out the order, please consult this catalogue.
- B) The undervoltage release is supplied for operation using a power supply branched on the supply side of the circuit-breaker or from an independent source. The circuit-breaker can only close when the release is energized (there is a mechanical lock on closing).
- C) In conformity with the Standards governing machine tools, contacts S4 shown in Fig. 15A can be used to open the Yu undervoltage release circuit (Fig. 6A) when the circuit-breaker is open and close it again upon a manual closing command from the rotary handle.
- E) For the EIA RS485 serial interface connection see document RH0298 regarding MODBUS communication.
- F) The auxiliary voltage Vaux allows actuation of all operations of the PR331/P, PR332/P and trip units.
Having requested a Vaux insulated from earth, one must use “galvanically separated converters” in compliance with IEC 60950 (UL 1950) or equivalent standards that ensure a common mode current or leakage current (see IEC 478/1, CEI 22/3) not greater than 3.5 mA, IEC 60364-41 and CEI 64-8.
- G) Earth fault protection is available with the PR332/P trip unit by means of a current sensor located on the conductor connecting to earth the star centre of the MV/LV transformer.
The connections between terminals 1 and 2 (or 3) of current transformer UI/O and poles T7 and T8 of the X (or XV) connector must be made with a two-pole shielded and stranded cable (see user manual), no more than 15 m long. The shield must be earthed on the circuit-breaker side and current sensor side.
- N) With PR332/P trip unit, the connections to the zone selectivity inputs and outputs must be made with a two-pole shielded and stranded cable (see user manual), no more than 300 m long. The shield must be earthed on the selectivity input side.
- O) Systems with rated voltage greater than 690V require the use of an insulation voltage transformer to connect to the busbars.
- P) With PR332/P trip unit with communication module PR330/D-M, the coils YO and YC can be controlled directly from contacts K51/YO and K51/YC with maximum voltages of 110-120 V DC e 240-250 V AC.
- Q) The second opening release may be installed as an alternative to the undervoltage release.
- R) The SACE SOR TEST UNIT + opening release (YO) is guaranteed to operate starting at 75% of the Vaux of the opening release itself.
While the YO power supply contact is closing (short-circuit on terminals 4 and 5), the SACE SOR TEST UNIT is unable to detect the opening coil status. Consequently:
– For continuously powered opening coil, the TEST FAILED and ALARM signals will be activated
– If the coil opening command is of the pulsing type, the TEST FAILED signal may appear at the same time. In this case, the TEST FAILED signal is actually an alarm signal only if it remains lit for more than 20s.
- S) The connection cable shield must only be earthed on the circuit-breaker side.
- T) The connections between the TO toroidal transformer and the poles of the X13 (or XV) connector of the circuit-breaker must be made using a four-pole shielded cable with paired braided conductors (BELDEN 9696 paired type), with a length of not more than 15 m. The shield must be earthed on the circuit-breaker side.

Wiring diagrams

Information for reading - ATS010 for T4-T5-T6

State of operation represented

The circuit diagram is for the following conditions:

- circuit-breakers open and connected
- circuit-breakers de-energized
- closing springs discharged
- overcurrent relays not tripped *

The present diagram shows withdrawable circuit-breakers, but is also valid for fixed circuit-breakers: connect terminal 17 to 20 and terminal 35 to 38 on the ATS010 device.

* The present diagram shows circuit-breakers with overcurrent trip unit (T4-T5), but is also valid for circuit-breakers with thermomagnetic trip unit and to circuit-breakers with out relay (switch-disconnectors): connect terminal 18 to 20 and terminal 35 to 37 of the ATS010 device.

@ The present diagram shows four-pole circuit-breakers but is also valid for two-pole circuit-breakers: use only terminals 26 and 24 (phase and neutral) for the voltage connection of the normal power supply to the ATS010 device; also use the Q61/2 two-pole rather than four-pole auxiliary protection circuit-breaker.

Caption

A	= Device type ATS010 for the automatic transfer switch of two circuit-breakers
A17	= Unit for M motor electrical latching
K1	= Auxiliary contactor type VB6-30-01 for the emergency supply voltage presence
K2	= Auxiliary contactor type VB6-30-01 for the normal supply voltage presence
K51/Q1	= Overcurrent release for emergency supply line*
K51/Q2	= Overcurrent release for normal supply line*
KC1-KC2	= Auxiliary contactors type BC6-30 for circuit-breaker closing
KO1-KO2	= Auxiliary contactors type BC6-30 for circuit-breaker opening
M	= Motor with series energization for the circuit-breaker opening and closing
Q/1	= Circuit-breaker auxiliary contact
Q1	= Circuit-breaker for emergency supply line
Q2	= Circuit-breaker for normal supply line
Q61/1-2	= Miniature circuit-breakers for auxiliary circuits protection @
S1, S2	= Position contact operated by a cam of the operating mechanism
S3	= Key lock contact operated by the remote opening trip unit or the operating mechanism
S11...S16	= Contacts for the ATS010 device inputs
S75I/1	= Contact signalling circuit-breaker in withdrawable version connected #
SY	= Contact signalling circuit-breaker tripped through trip units operation (tripped position)*
TI/...	= Current transformers feeding the overcurrent relay
X2	= Connector for the circuit-breaker auxiliary circuits
XV	= Terminal boards of the accessories.

Wiring diagrams

Information for reading - ATS010 for T7

State of operation represented

The circuit diagrams are for the following conditions:

- circuit-breakers open and connected
- circuits de-energized
- closing springs discharged
- overcurrent relays not tripped *
- ATS010 not powered
- generator in automatic mode, not started
- transfer switch enabled
- generator not in alarm
- logic enabling command on (terminal 47).

The present diagram shows withdrawable circuit-breakers, but is also valid for fixed circuit-breakers: circuit-breaker auxiliary circuits are not connected to X12-X15 connectors but to the XV terminal board; furthermore connect terminal 17 to 20 and terminal 35 to 38 on the ATS010 device.

* The present diagram shows circuit-breakers with overcurrent trip unit, but is also valid for circuit-breakers with thermomagnetic trip unit and to circuit-breakers with out relay (switch-disconnectors): connect terminal 18 to 20 and terminal 35 to 37 of the ATS010 device.

@ The present diagram shows four-pole circuit-breakers but is also valid for two-pole circuit-breakers: use only terminals 26 and 24 (phase and neutral) for the voltage connection of the normal power supply to the ATS010 device; also use the Q61/2 two-pole rather than four-pole auxiliary protection circuit-breaker.

Caption

A	= Device type ATS010 for the automatic transfer switch of two circuit-breakers
K1	= Auxiliary contactor type VB6-30-01 for the emergency supply voltage presence
K2	= Auxiliary contactor type VB6-30-01 for the normal supply voltage presence
K51/Q1	= Overcurrent release for emergency supply line*
K51/Q2	= Overcurrent release for normal supply line*
KC1-KC2	= Auxiliary contactors type BC6-30 for circuit-breaker closing
KO1-KO2	= Auxiliary contactors type BC6-30 for circuit-breaker opening
M	= Motor with series energization for the circuit-breaker opening and closing
Q/1	= Circuit-breaker auxiliary contact
Q1	= Circuit-breaker for emergency supply line
Q2	= Circuit-breaker for normal supply line
Q61/1-2	= Miniature circuit-breakers for auxiliary circuits protection @
S11...S16	= Contacts for the ATS010 device inputs
S33M/1	= Limit switch of the closing springs
S51	= Contact signalling circuit-breaker tripped through the overcurrent relay *
S75I/1	= Contact signalling circuit-breaker in withdrawable version connected #
TI/...	= Current transformers feeding the overcurrent relay
X12-X15	= Connectors for the auxiliary circuits of the circuit-breaker in withdrawable version
XF	= Terminal board for the position contacts of the withdrawable circuit-breaker
XV	= Terminal boards of the accessories.
YC	= Shunt closing release
YO	= Shunt opening release

Note

- A) For the auxiliary circuits of the circuit-breakers see the relative diagrams. The applications indicated in the following figures are compulsory: 1A - 2A - 4A - 13A (only if the overcurrent release is supplied) - 22A - 31A (only for withdrawable version circuit-breakers).

Wiring diagrams

Graphic symbols (IEC 60617 and CEI 3-14...3-26 Standards)

	Thermal effect		Connection of conductors		Position switch (limit switch), break contact		Differential current relay
	Electromagnetic effect		Terminal		Position switch (limit switch) change-over break before make contact		Phase-failure detection relay in a three-phase system
	Delay		Plug and socket (male and female)		Contactor (contact open in the unoperated position)		Locked-rotor detection relay operating by current sensing
	Mechanical connection (link)		Resistor (general symbol)		Circuit-breaker disconnecter with automatic trip unit		Lamp, general symbol
	Manually operated control (general case)		Temperature dependent resistor		Switch-disconnector (on-load isolating switch)		Mechanical interlock between two devices
	Operated by turning		Motor (general symbol)		Operating device (general symbol)		Operated by electric motor
	Operated by pushing		Induction motor, three-phase, squirrel cage		Thermal relay		Motor with series energization
	Operated by key		Current transformer		Instantaneous overcurrent or rate-of-rise relay		Screen, shield (it may be drawn in any convenient shape)
	Operated by cam		Current transformer with four threaded winding and with one permanent winding with one tapping		Overcurrent relay with adjustable short time-lag characteristic		Equipotentiality
	Earth, ground (general symbol)		Make contact		Overcurrent relay with inverse short time-lag characteristic		Voltage transformer
	Converter with galvanic separator		Break contact		Overcurrent relay with inverse long time-lag characteristic		Winding of three-phase transformer, connection star
	Conductors in a screened cable, two conductors shown		Change-over break before make contact		Earth fault overcurrent relay with inverse short time-lag characteristic		Current sensing element
	Twisted conductors, two conductors shown		Position switch (limit switch), make contact		Phase-balance current relay		

Wiring diagrams

Wiring diagram of the T1...T6 circuit-breakers

State of operation

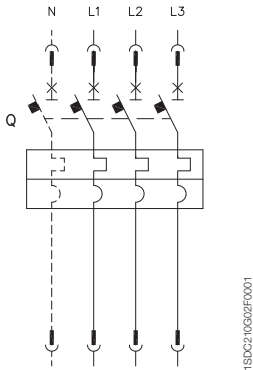

Three-pole or four-pole circuit-breaker with thermomagnetic trip unit

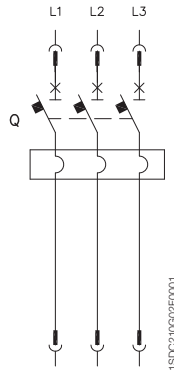

Three-pole circuit-breaker with magnetic trip unit

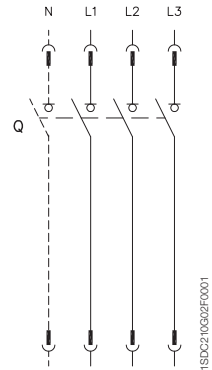

Three-pole or four-pole switch-disconnector (on-load isolating switch)

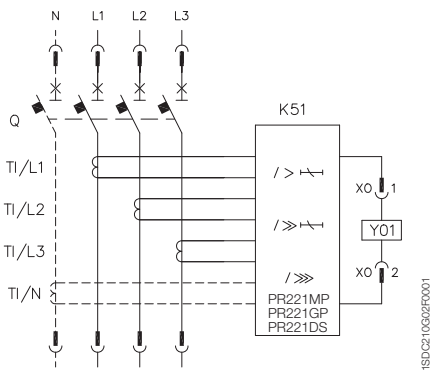

Three-pole or four-pole circuit-breaker with PR221 electronic trip unit

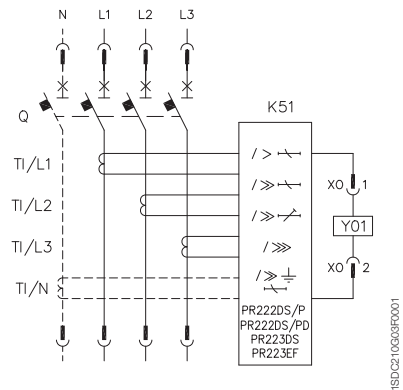

Three-pole or four-pole circuit-breaker with PR222DS/P, PR222DS/PD, PR223DS or PR223EF electronic trip unit (for T4, T5 and T6)

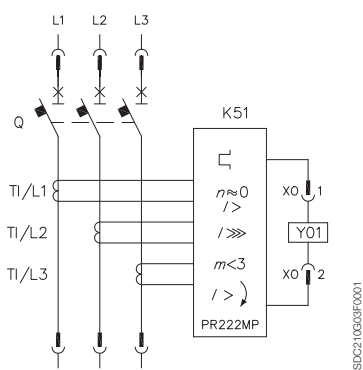

Three-pole circuit-breaker with PR222MP electronic trip unit

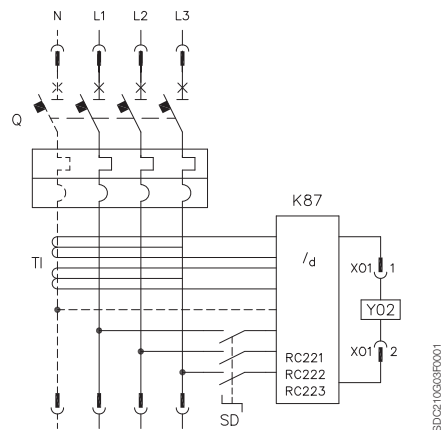

Three-pole or four-pole circuit-breaker with RC221, RC222 or RC223 residual current trip unit

Wiring diagrams

Wiring diagram of the T1...T6 circuit-breakers

State of operation

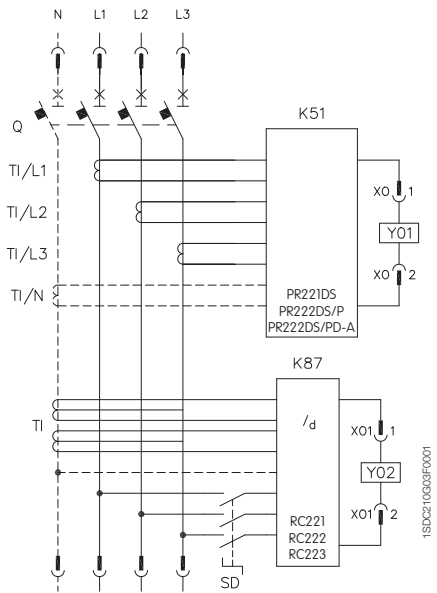

Three-pole or four-pole circuit-breaker with PR221DS, PR222DS/P or PR222DS/PD electronic trip unit and RC221, RC222 or RC223 residual current trip unit (for T4, T5 and T6 four-pole only)

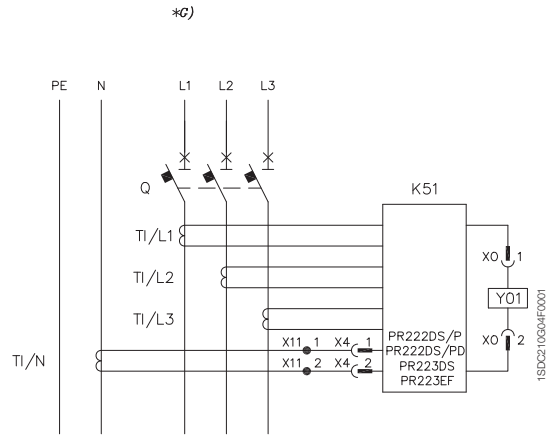

Fixed version three-pole circuit-breaker with current transformer on neutral conductor, external to circuit-breaker (for T4, T5 and T6)

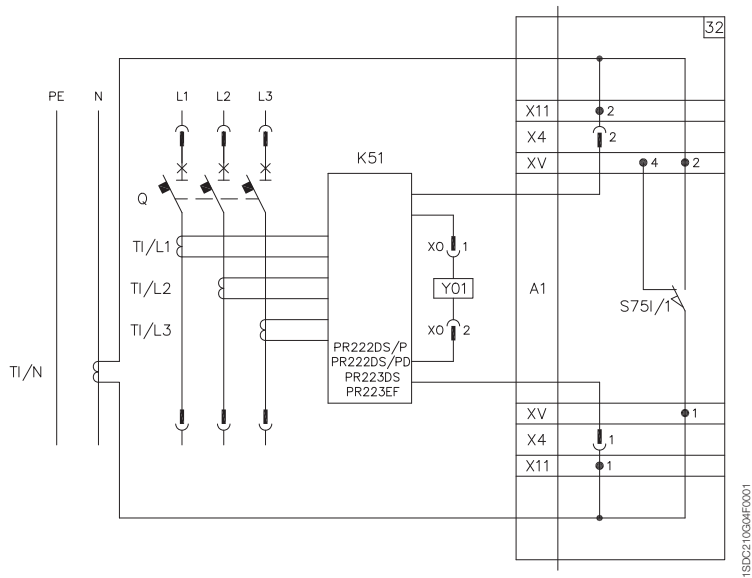

Plug-in or withdrawable version three-pole circuit-breaker with current transformer on neutral conductor, external to circuit-breaker (for T4, T5 and T6)

Wiring diagrams

Wiring diagram of the T7 circuit-breakers

State of operation

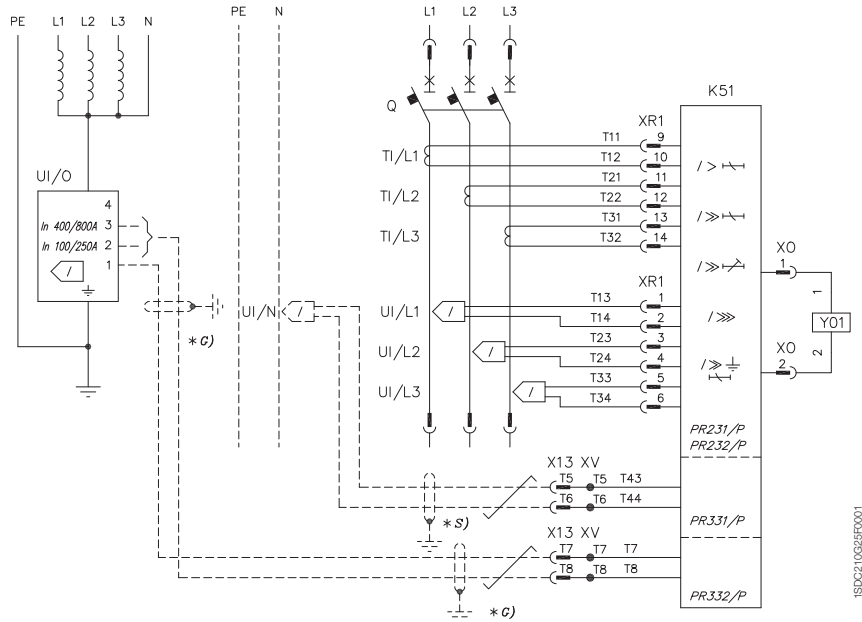

Three-pole circuit-breaker with PR231/P, PR232/P, PR331/P, PR332/P electronic trip unit

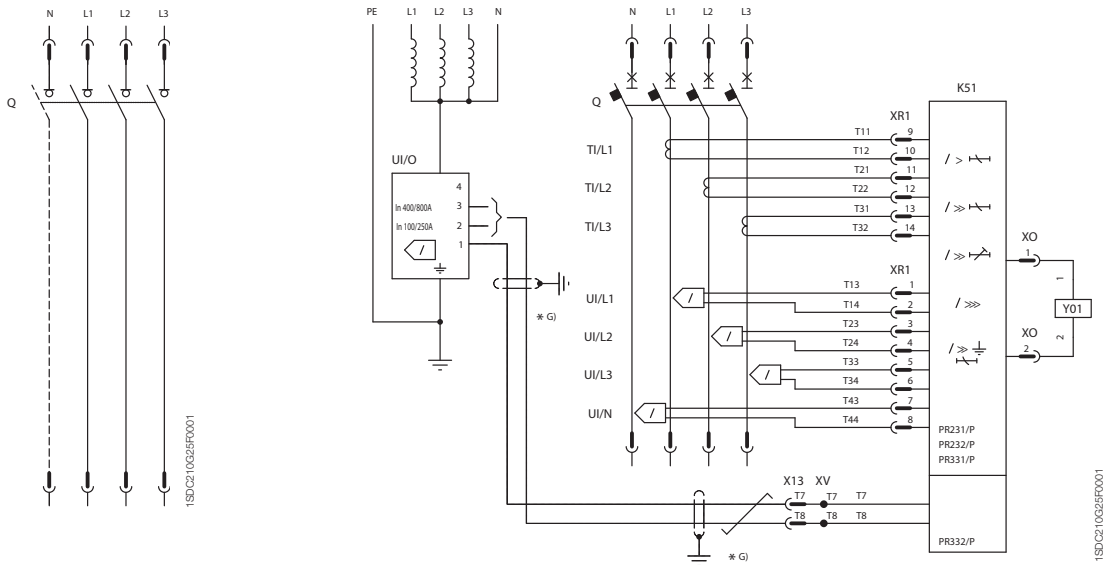

Three- or four-pole switch-disconnector

Four-pole circuit-breaker with PR231/P, PR232/P, PR331/P, PR332/P electronic trip unit

Wiring diagrams

Electrical accessories for T1...T6

Shunt opening and undervoltage releases

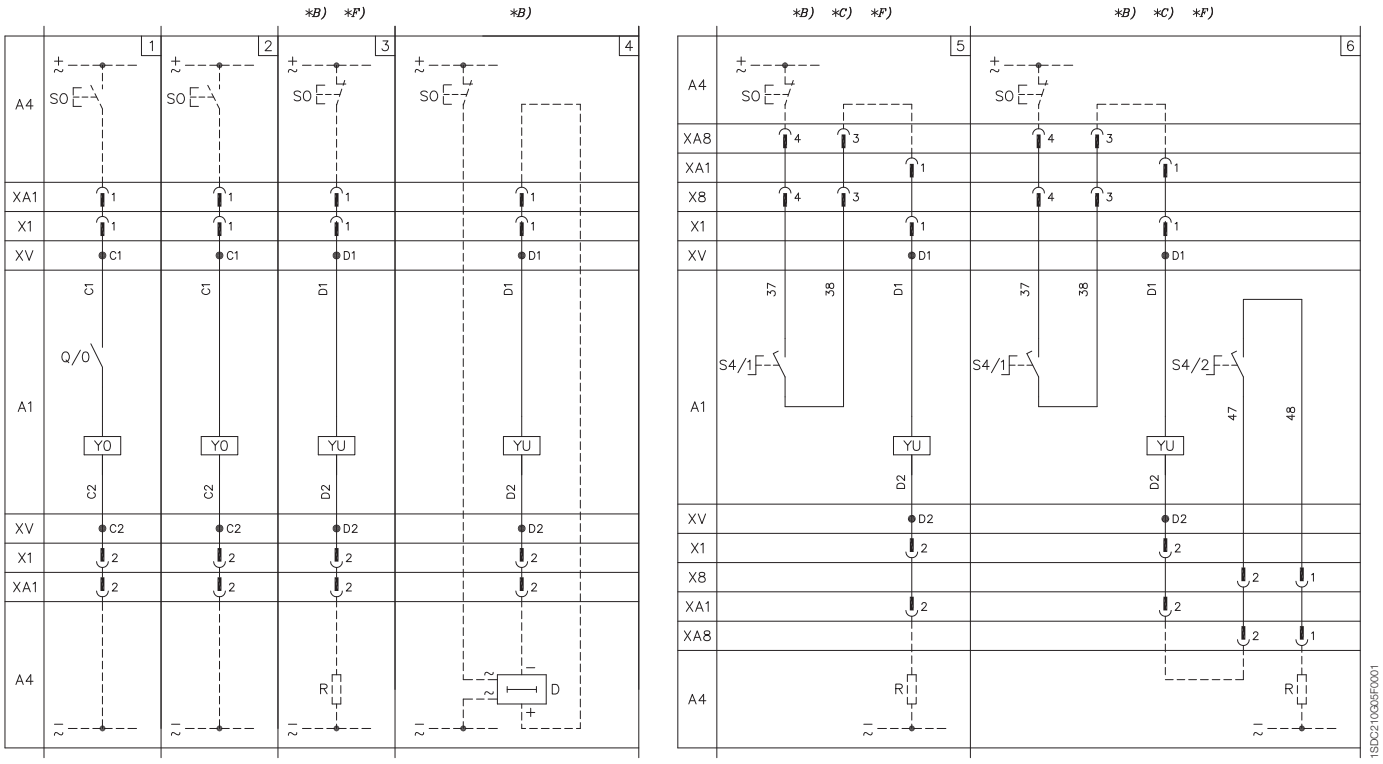

Residual current releases and remote controls

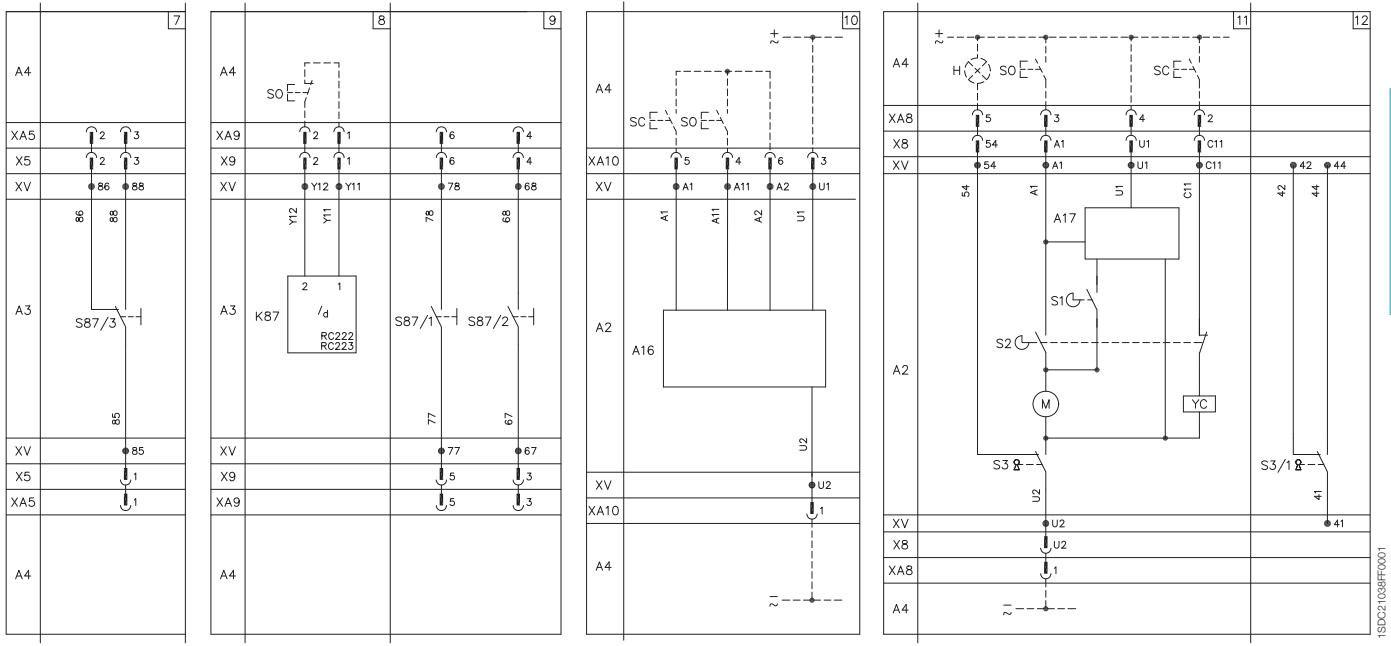

1SDC21036F0001

5

1SDC21036F0001

Wiring diagrams

Electrical accessories for T1...T6

Auxiliary contacts

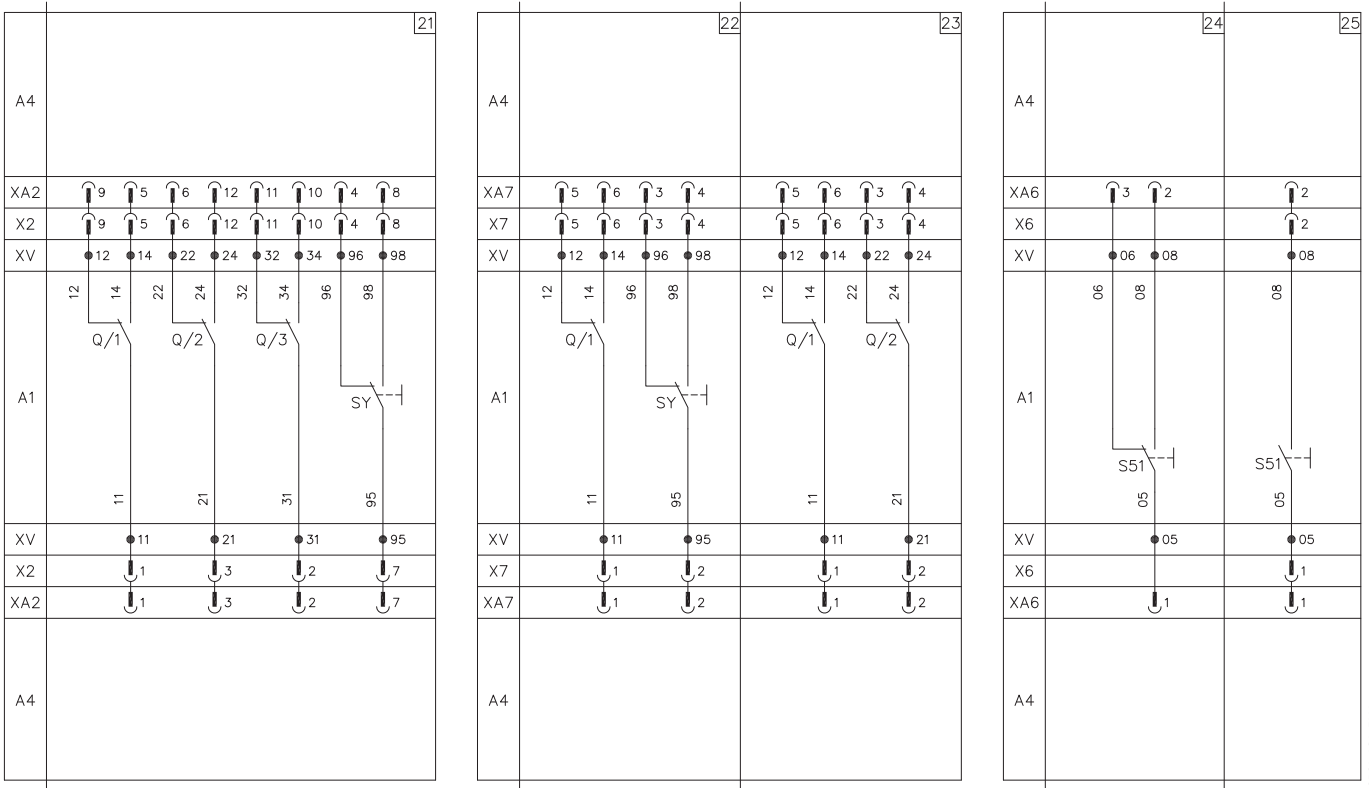

1SDC210G07F0001

Position contacts

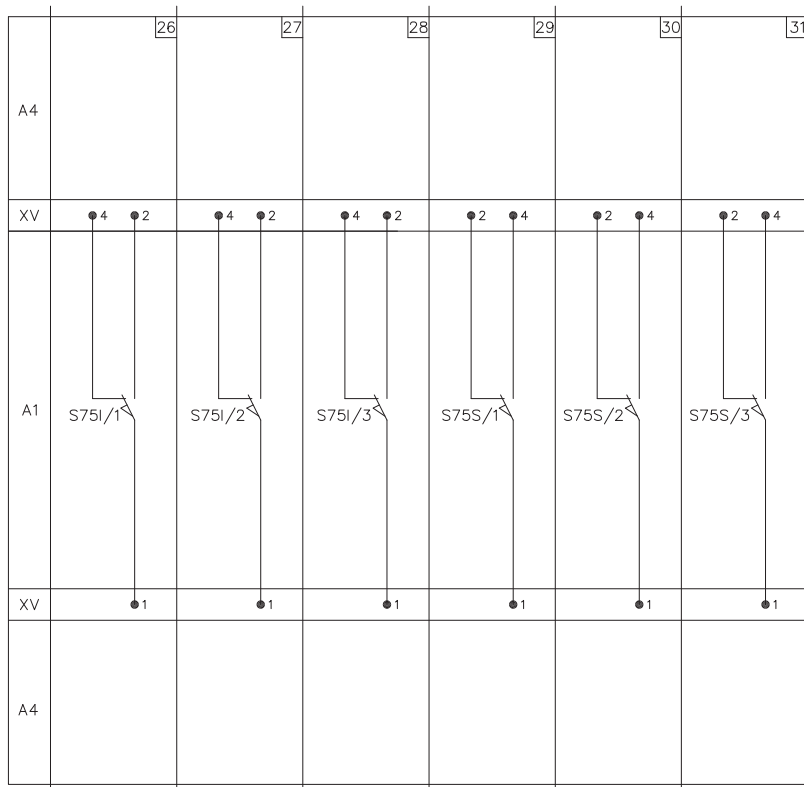

1SDC210G08F0001

PR223DS electronic trip unit connected with the VM210 voltage measuring device

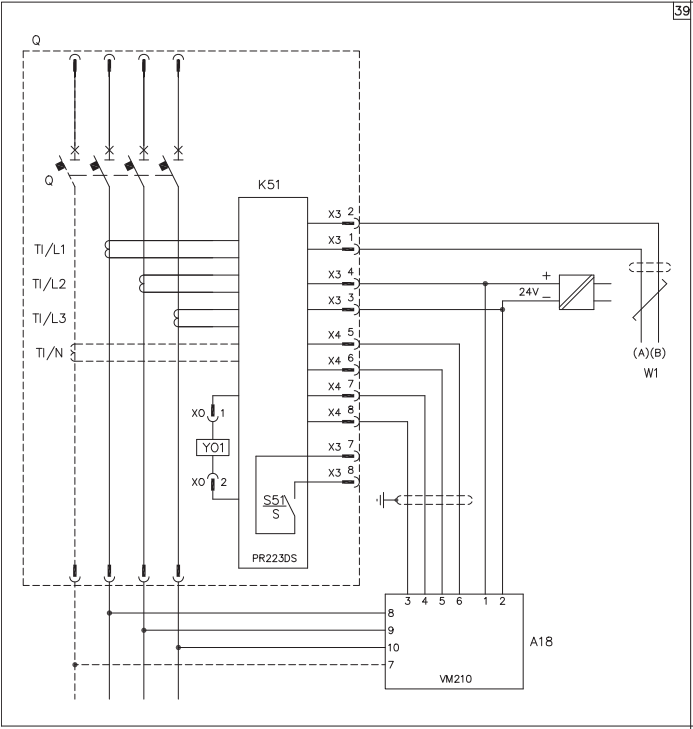

PR223EF electronic trip unit connected with the VM210 voltage measuring device

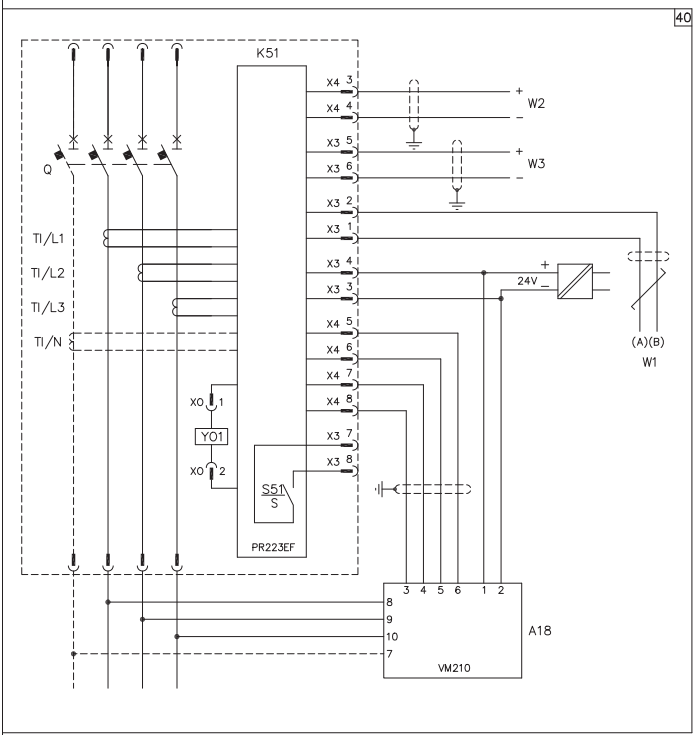

Wiring diagrams

Electrical accessories for T1...T6

PR222DS/P, PR222DS/PD, PR223DS or PR223EF electronic trip unit connected with the FDU front display unit

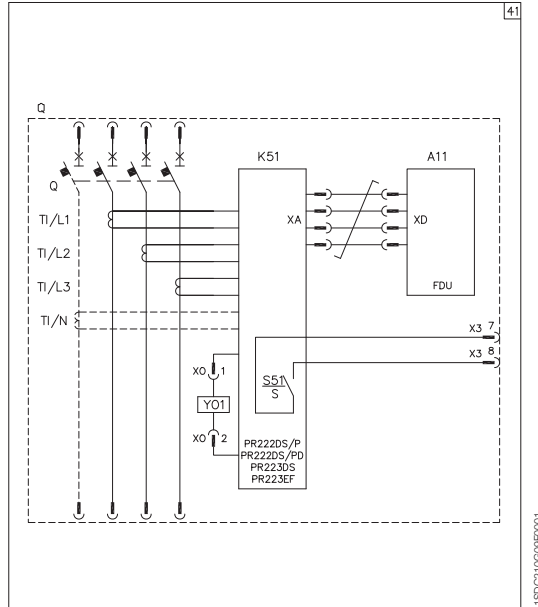

PR222DS/PD, PR223DS or PR223EF electronic trip unit connected with the PR021/K signalling unit

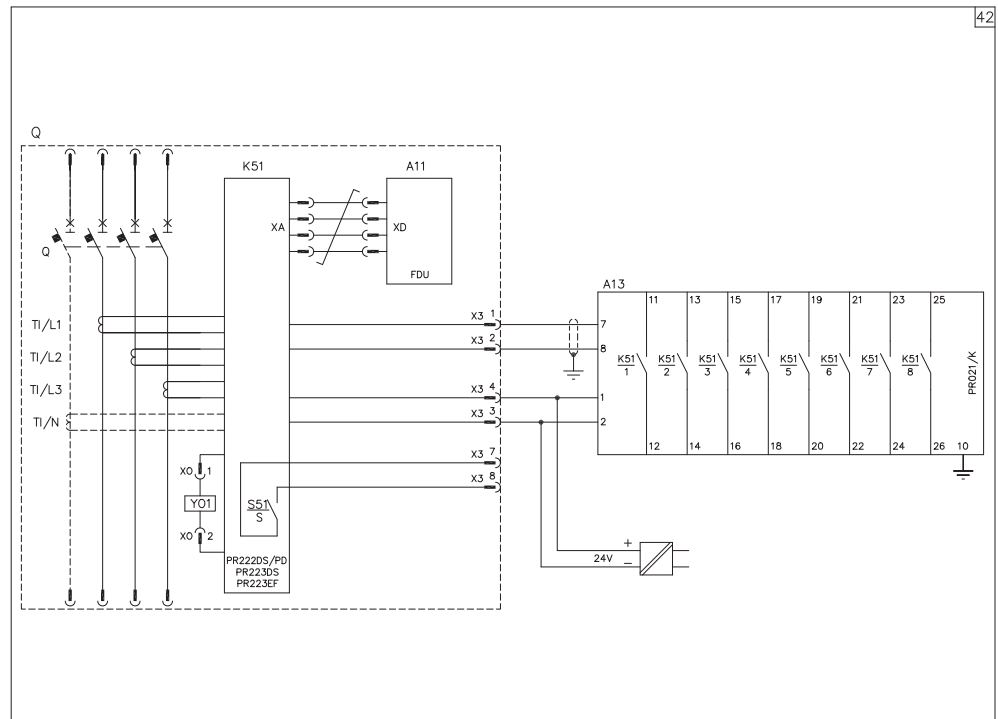

5

PR222DS/PD, PR223DS or PR223EF electronic trip unit connected with the FDU front display unit and the PR021/K signalling unit

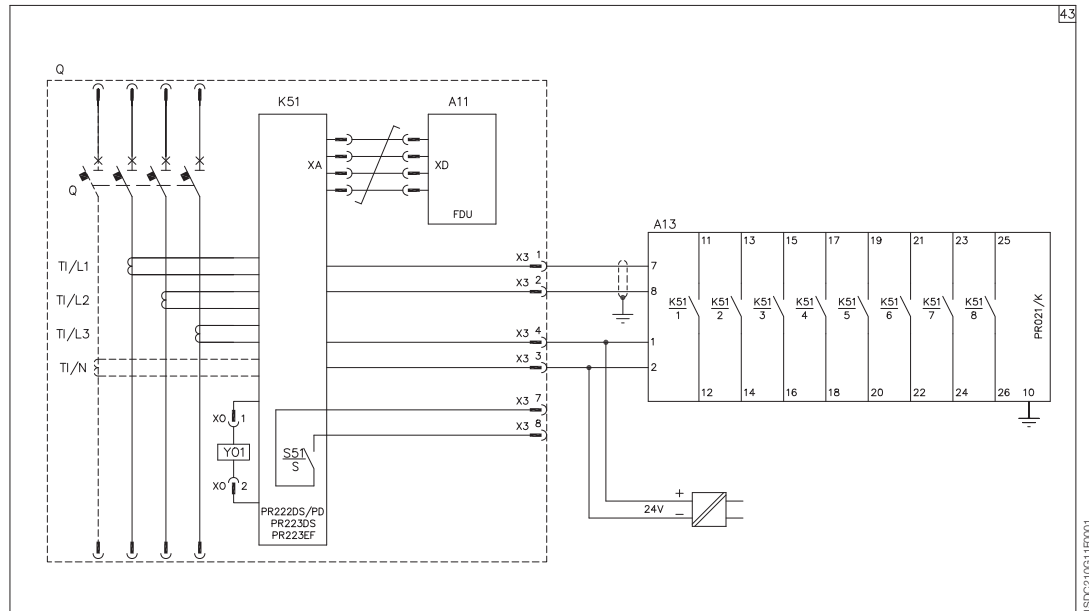

PR222DS/PD, PR223DS or PR223EF electronic trip unit connected with the AUX-E auxiliary contacts

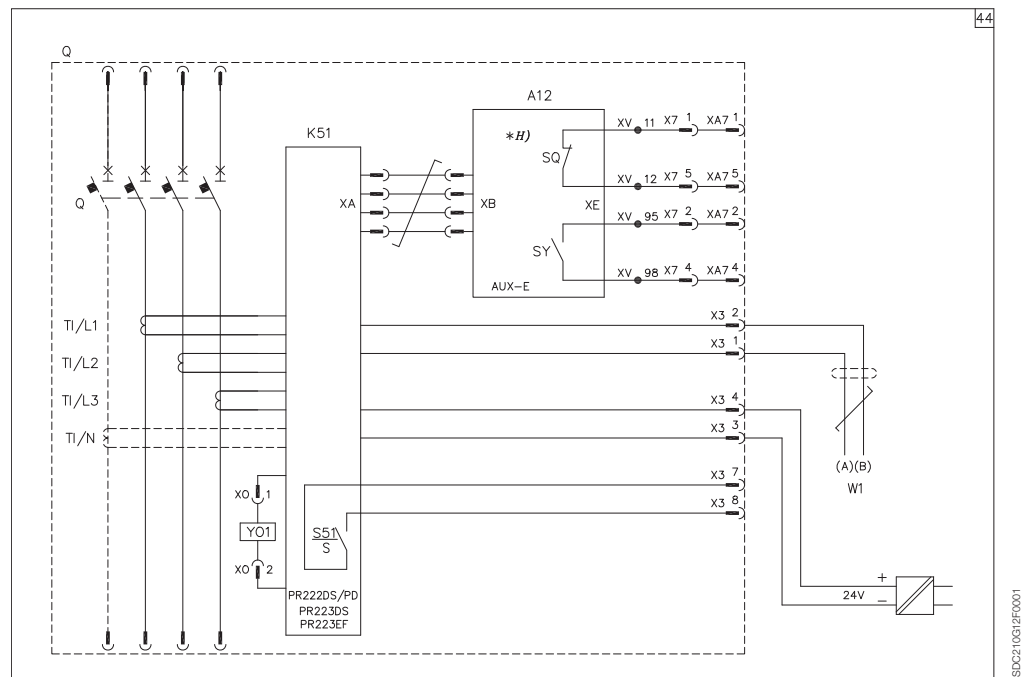

Wiring diagrams

Electrical accessories for T1...T6

PR222DS/PD, PR223DS or PR223EF electronic trip unit connected with the AUX-E auxiliary contacts and the MOE-E actuation unit

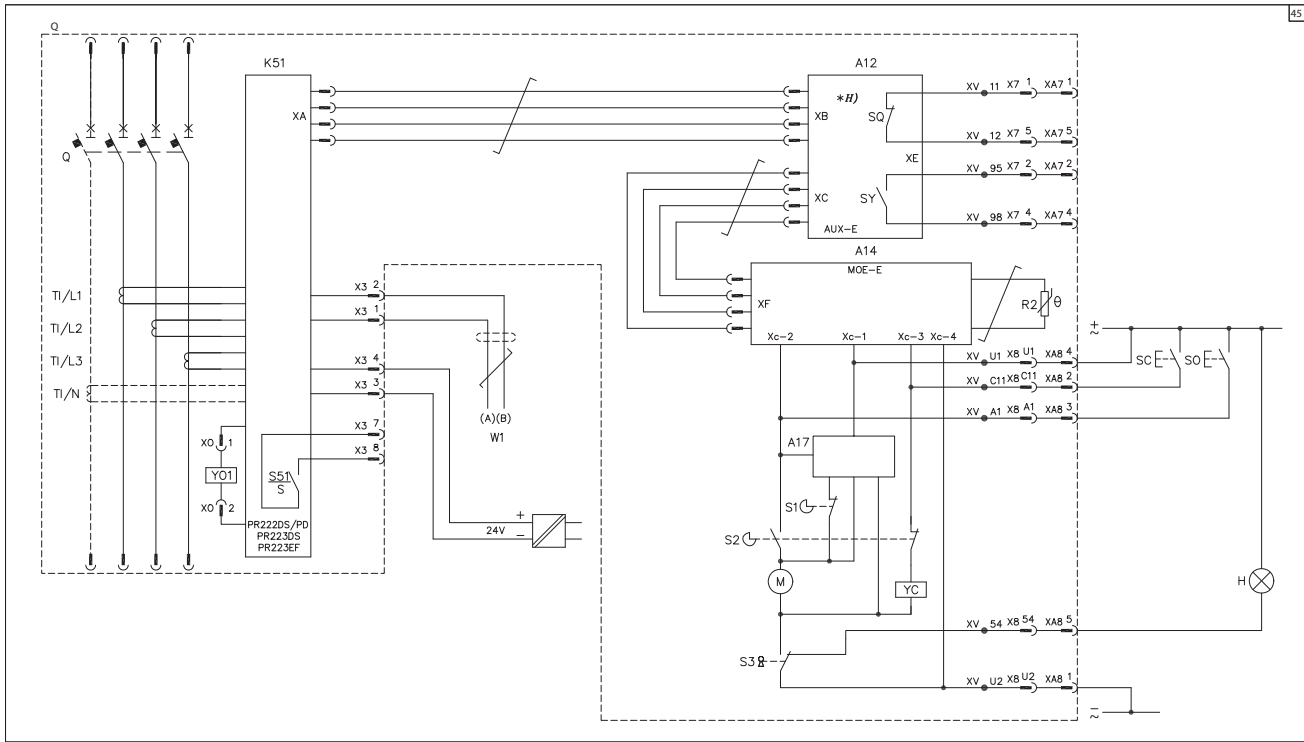

PR222DS/PD, PR223DS or PR223EF electronic trip unit connected with the FDU front display unit and with the AUX-E auxiliary contacts

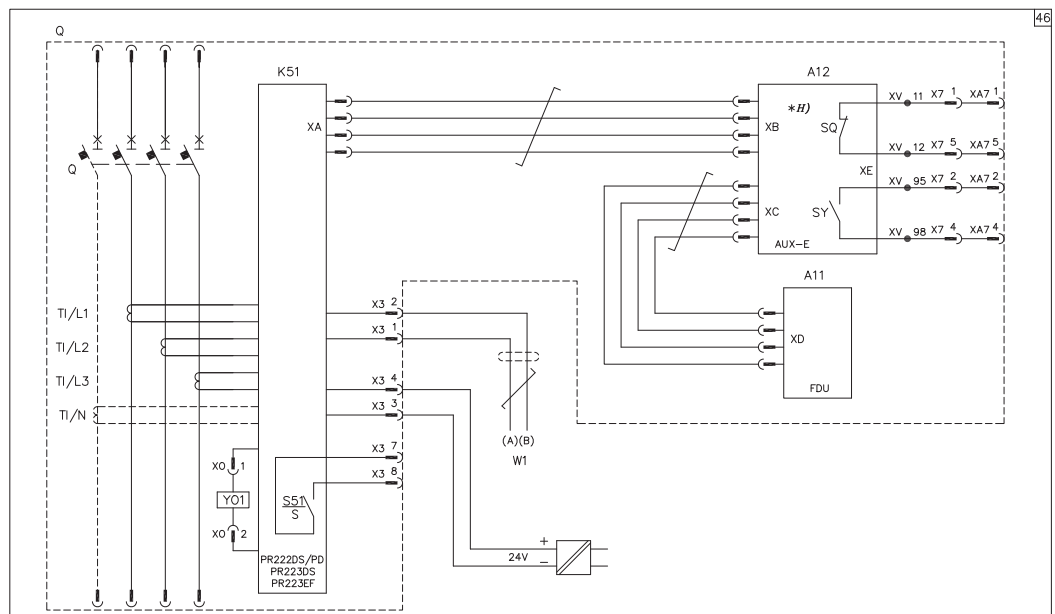

5

PR222MP electronic trip unit connected with the PR021/K signalling unit

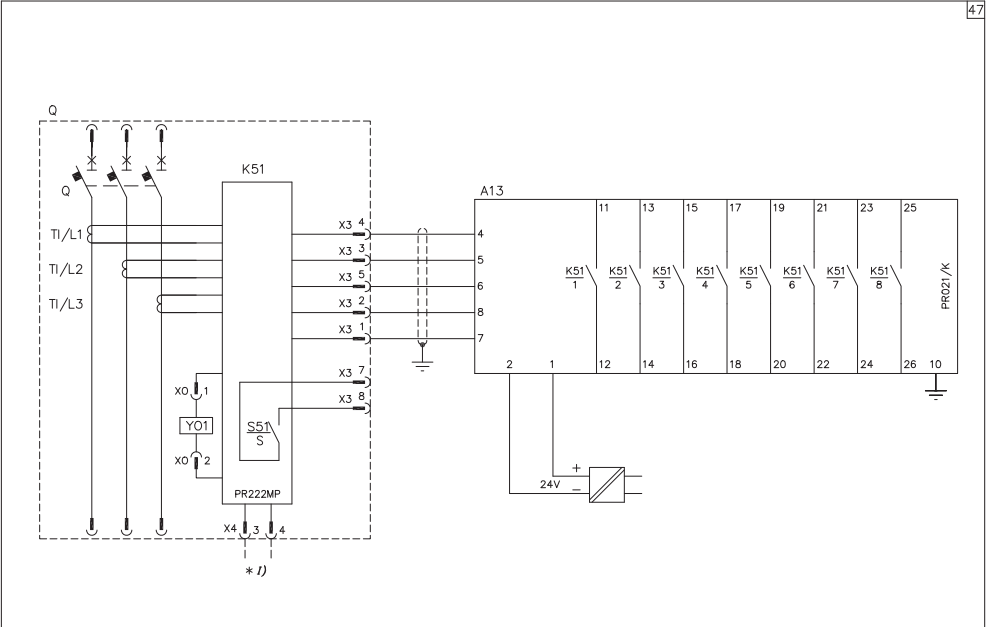

1SDC210318FC001

PR222MP electronic trip unit connected with the PR021/K signalling unit and with the PR212/CI contactor control unit

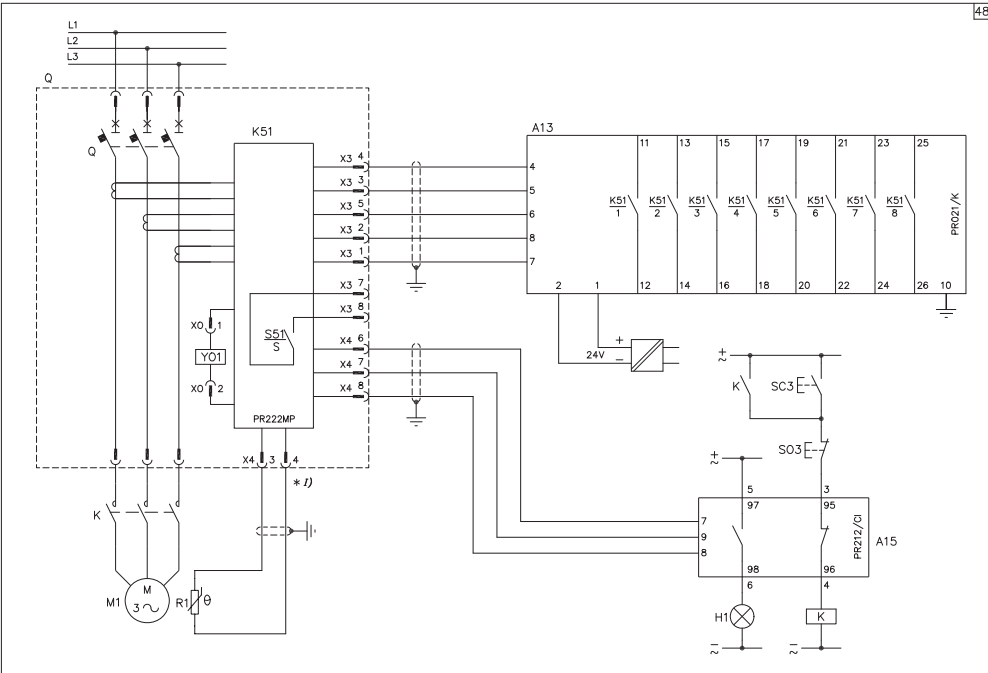

1SDC210318FC001

⁽¹⁾ As an alternative to generic contact 0/1

Wiring diagrams

Electrical accessories for T1...T6

PR22MP electronic trip unit connected with the PR021/K signalling unit, with the PR212/CI contactor control unit and with a contactor

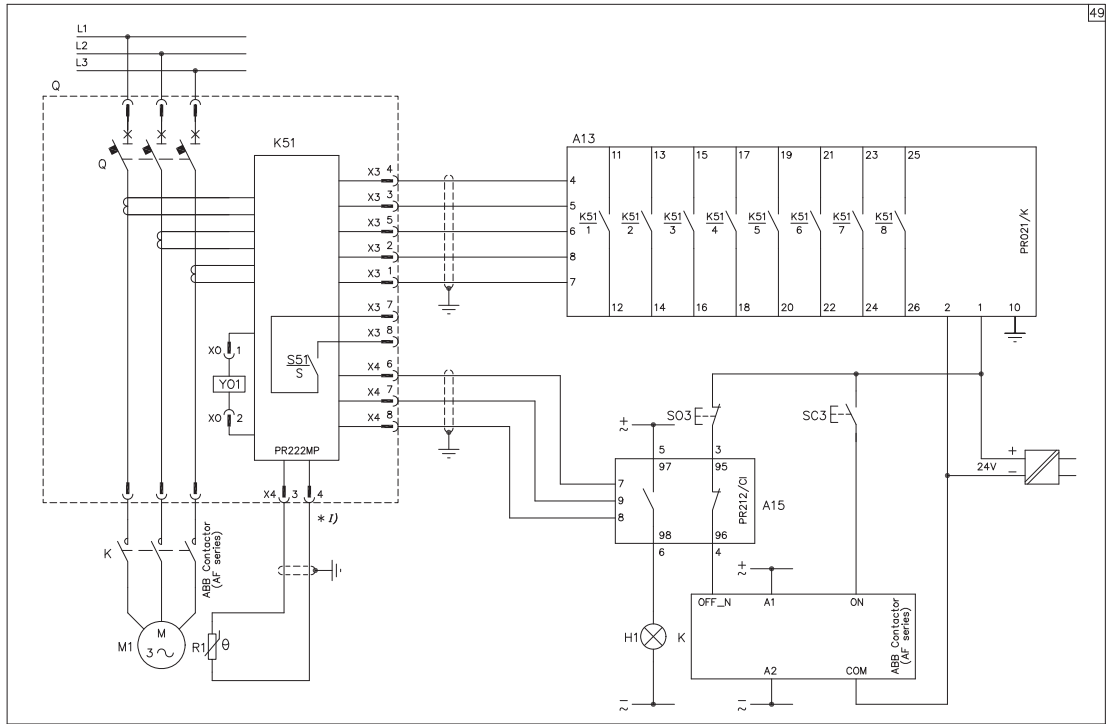

□ As an alternative to generic contact 0/1

1SDC21031TF0001

PR222MP electronic trip unit with auxiliary power supply and PR212/CI contactor control unit

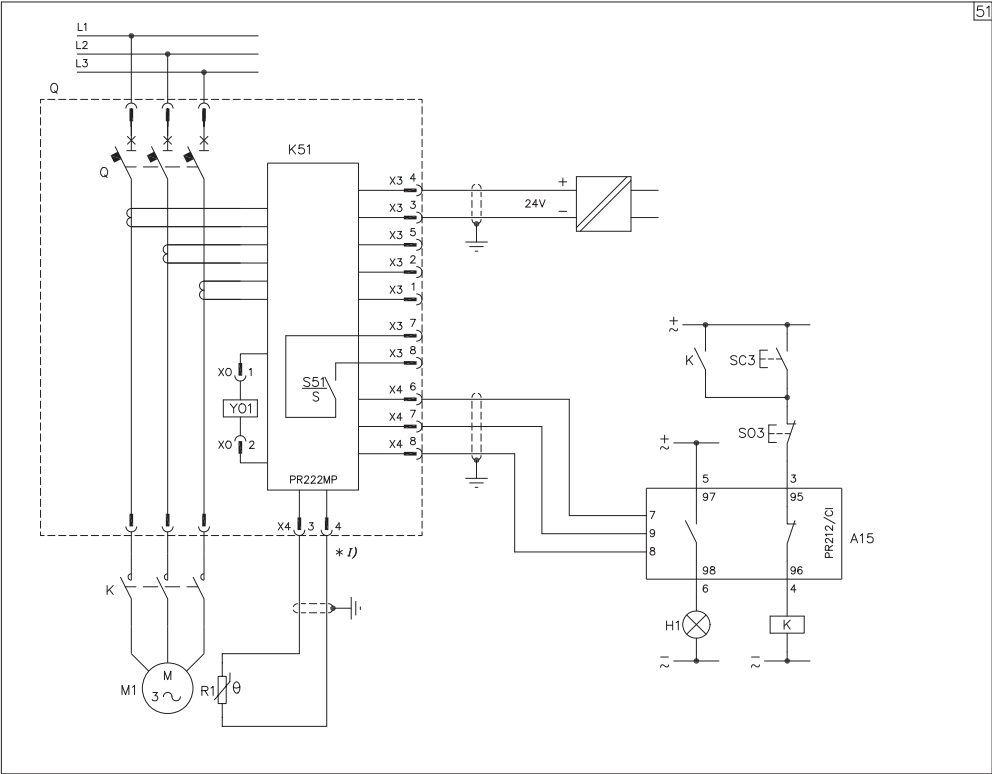

¹⁾ As an alternative to generic contact 0/1

1SDC210330F0001

Wiring diagrams

Electrical accessories for T7

Motor operating mechanism, opening, closing and undervoltage releases

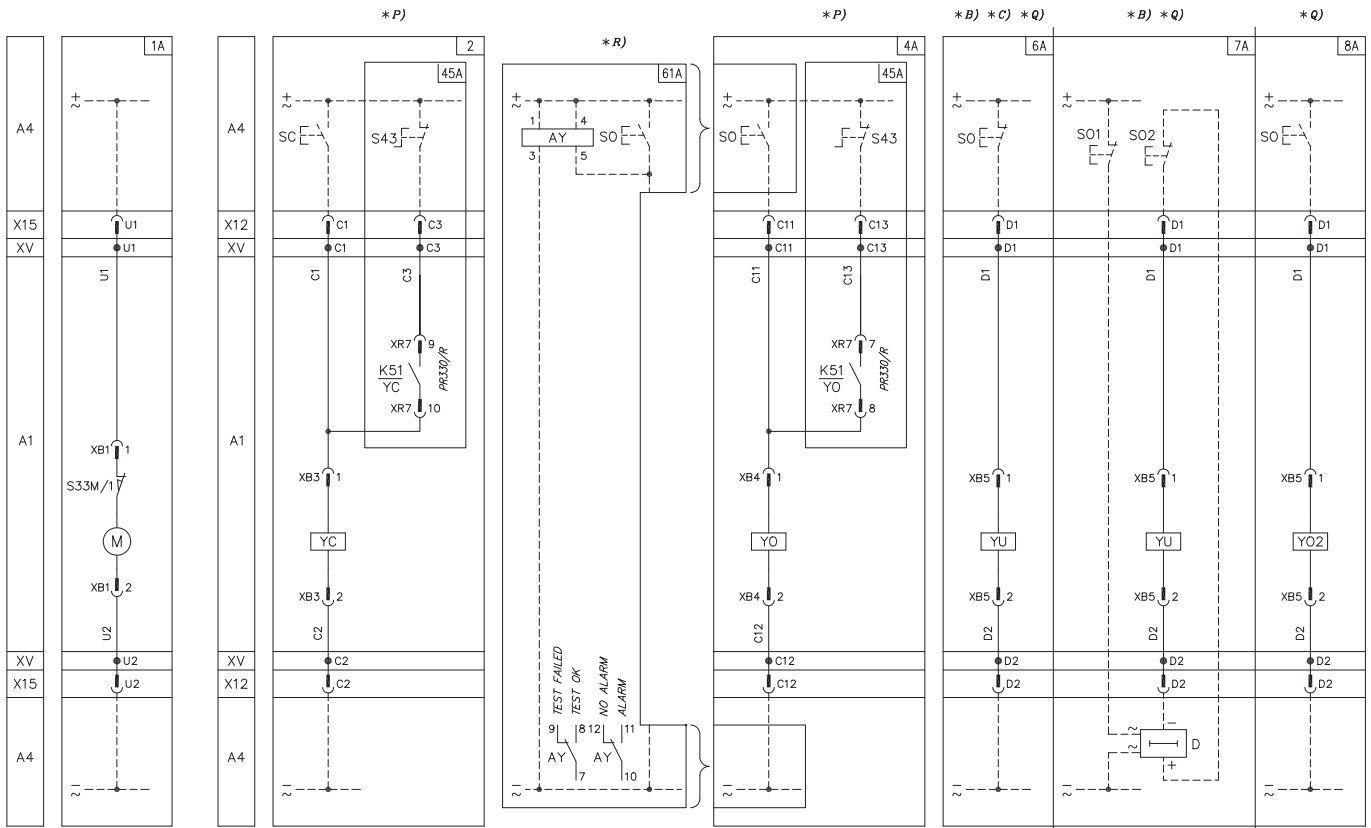

1SDC210G29F0001

Signalling contacts

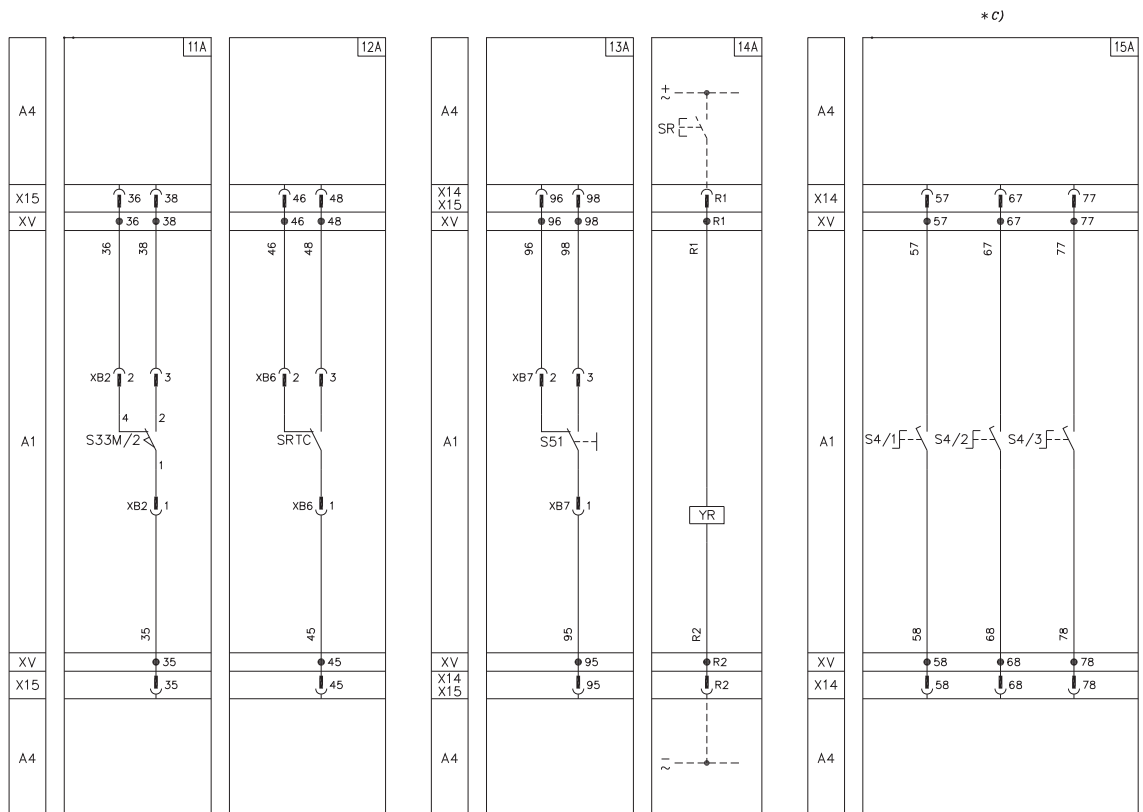

1SDC210G29F0001

Signalling contacts

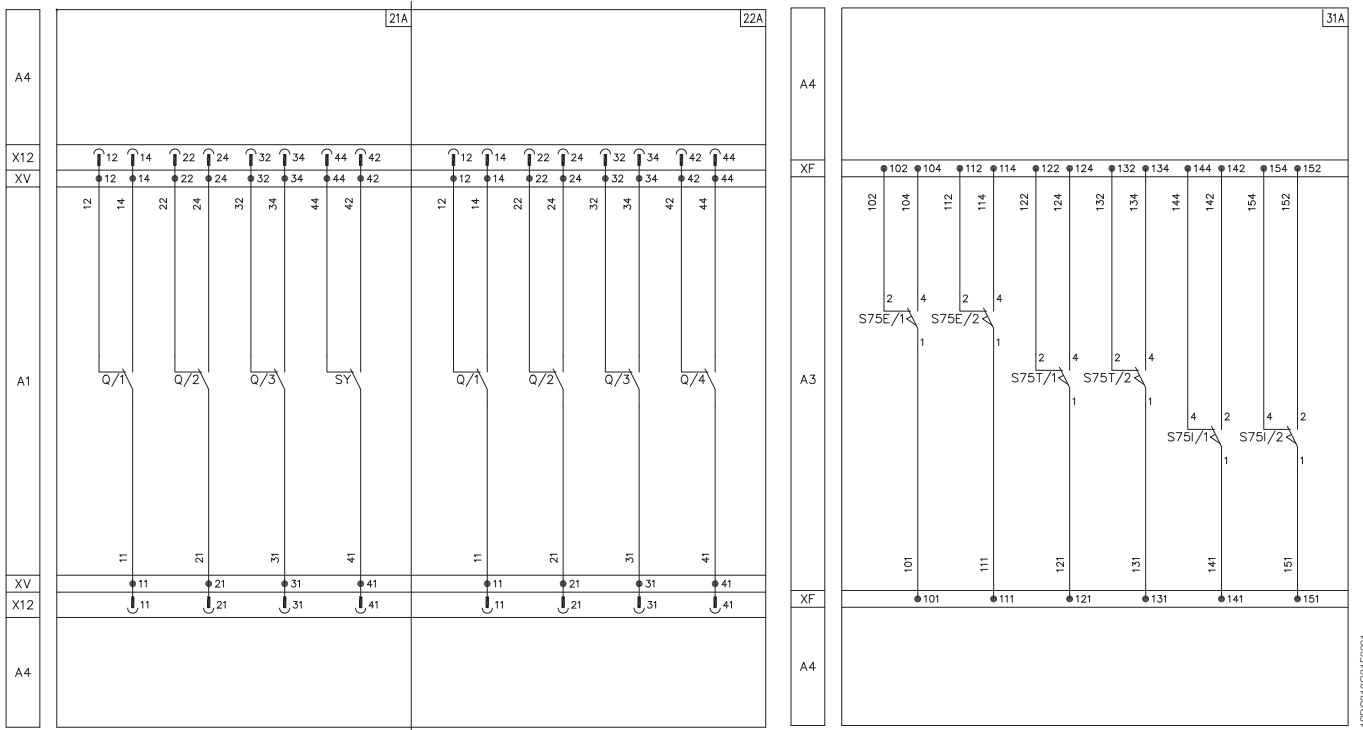

Auxiliary circuits of the PR331/P and PR332/P trip units

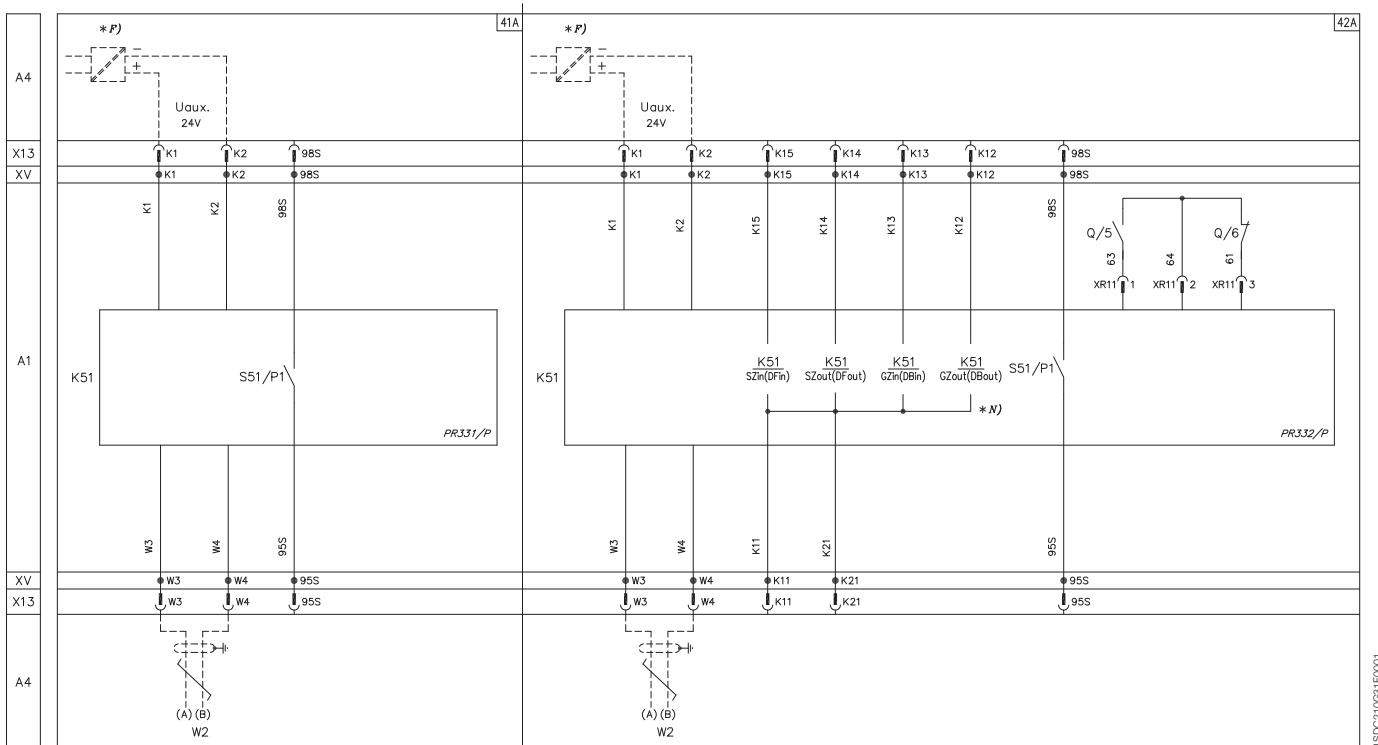

Wiring diagrams

Electrical accessories for T7

PR332/P electronic trip units connected to PR330/R actuation unit and PR330/D-M dialogue unit

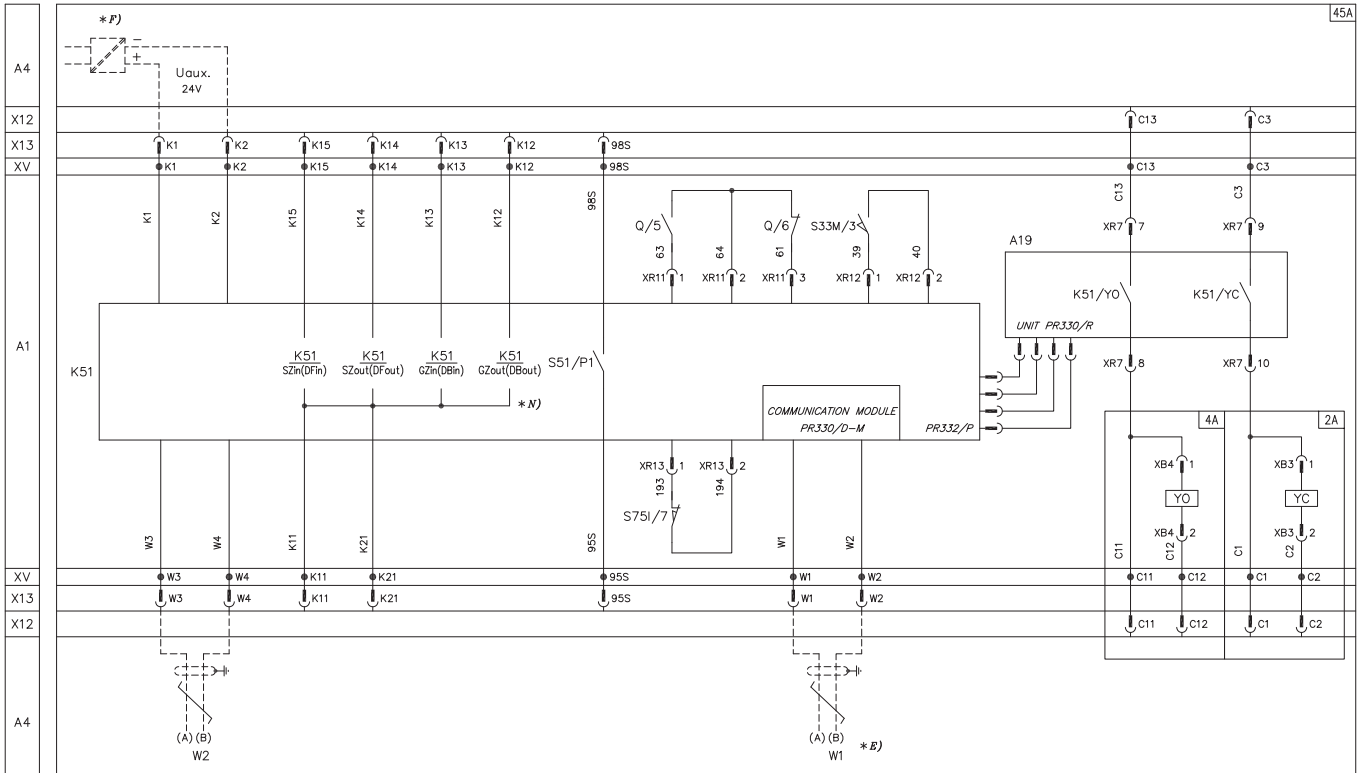

Measuring module PR330/V

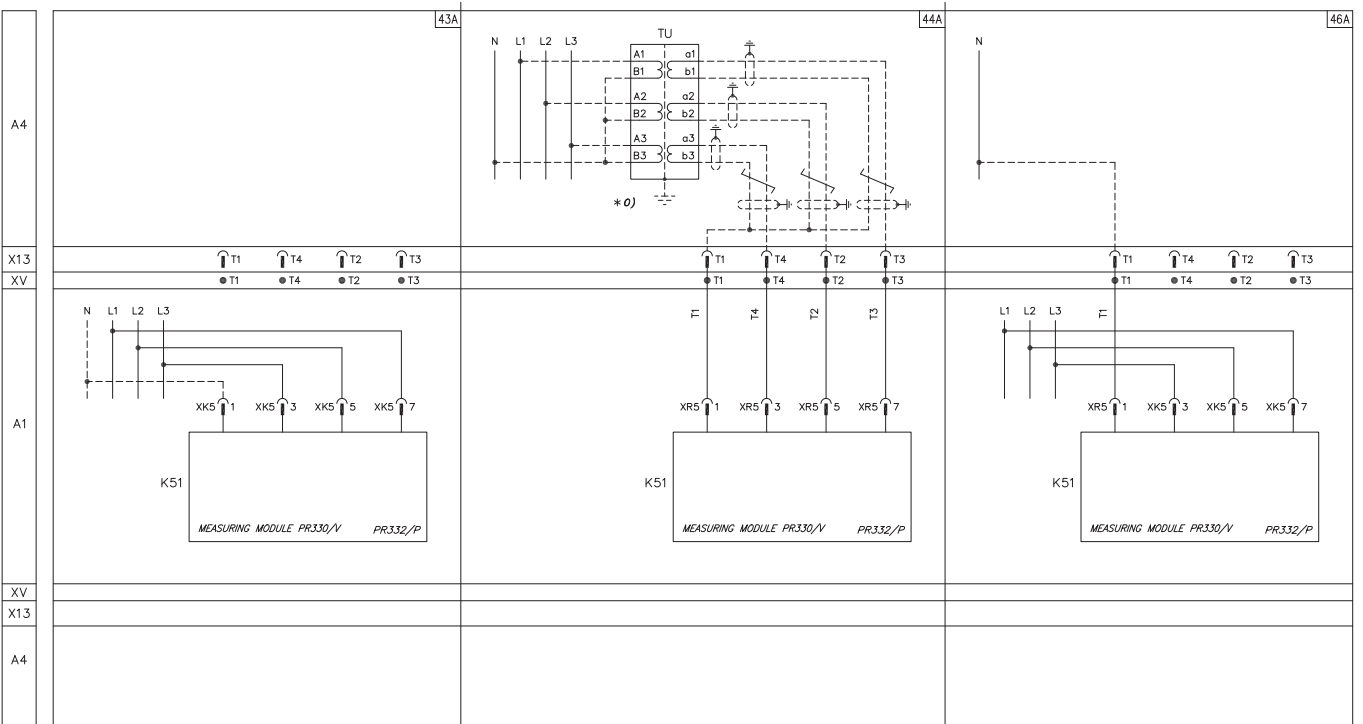

PR021/K signalling unit for PR331/P and PR332/P

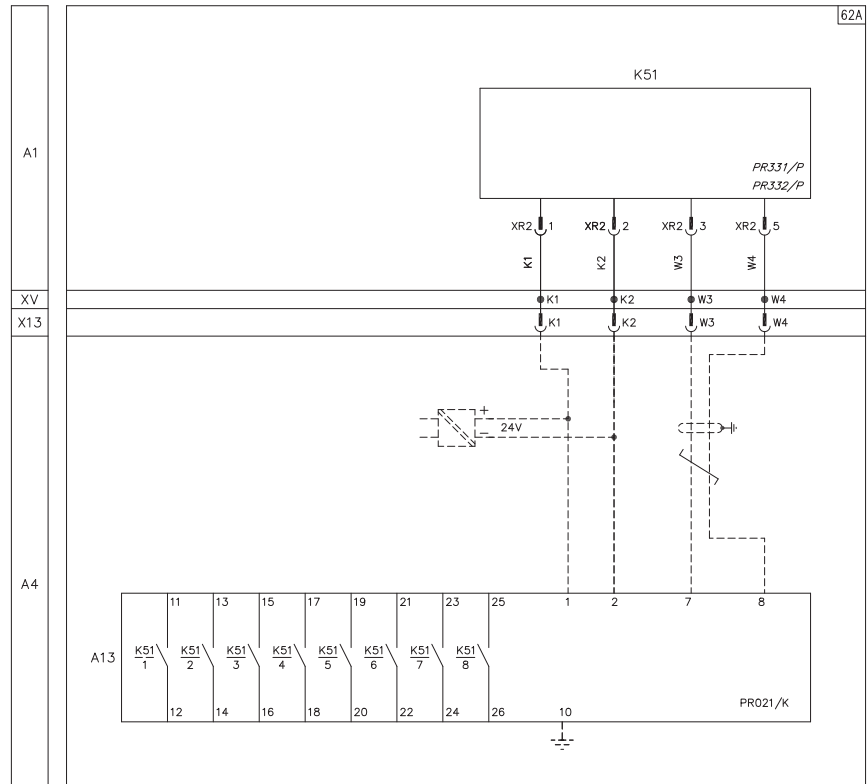

1SDC210048R0001

Wiring diagrams

Automatic transfer-switch ATS010 for T4-T5-T6

ATS010 device for the automatic transfer switch of two T4-T5-T6 circuit-breakers without safety auxiliary voltage supply

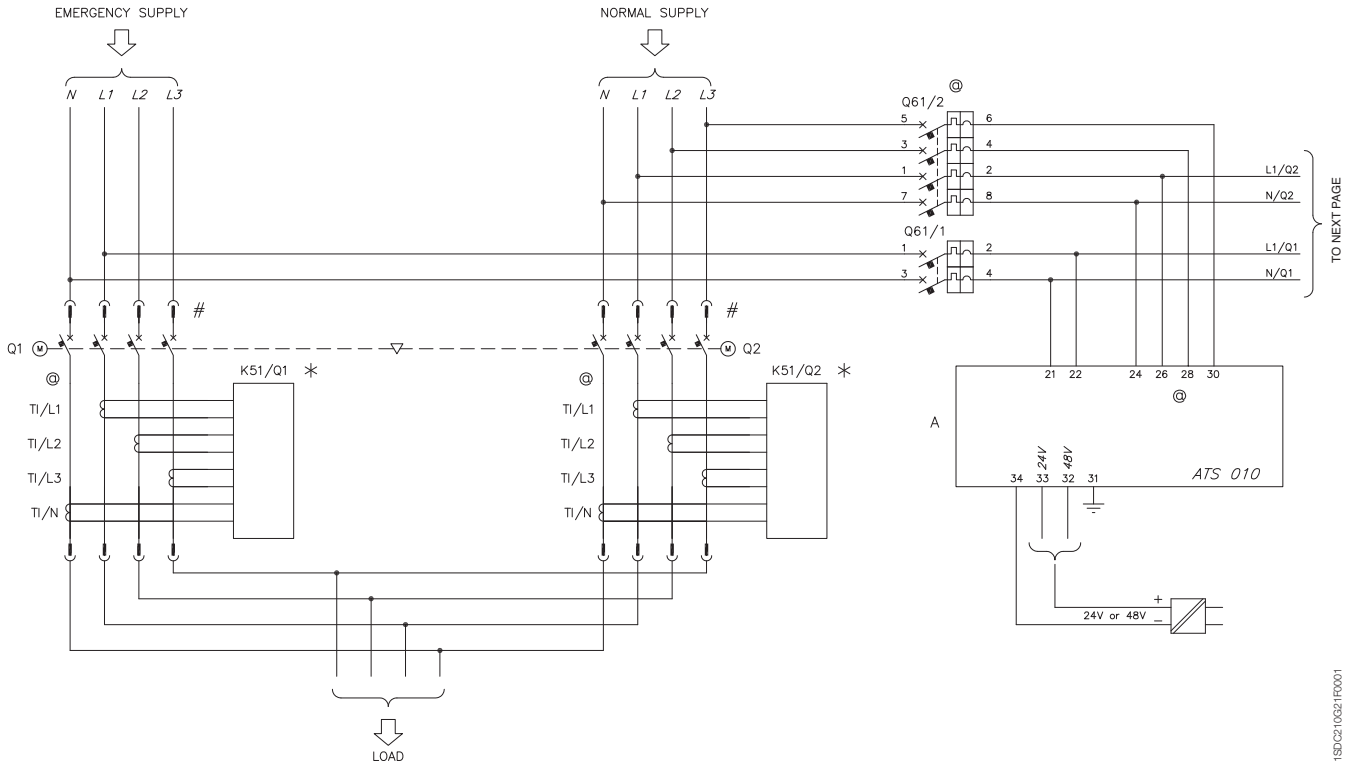

1SD0310621F0001

5

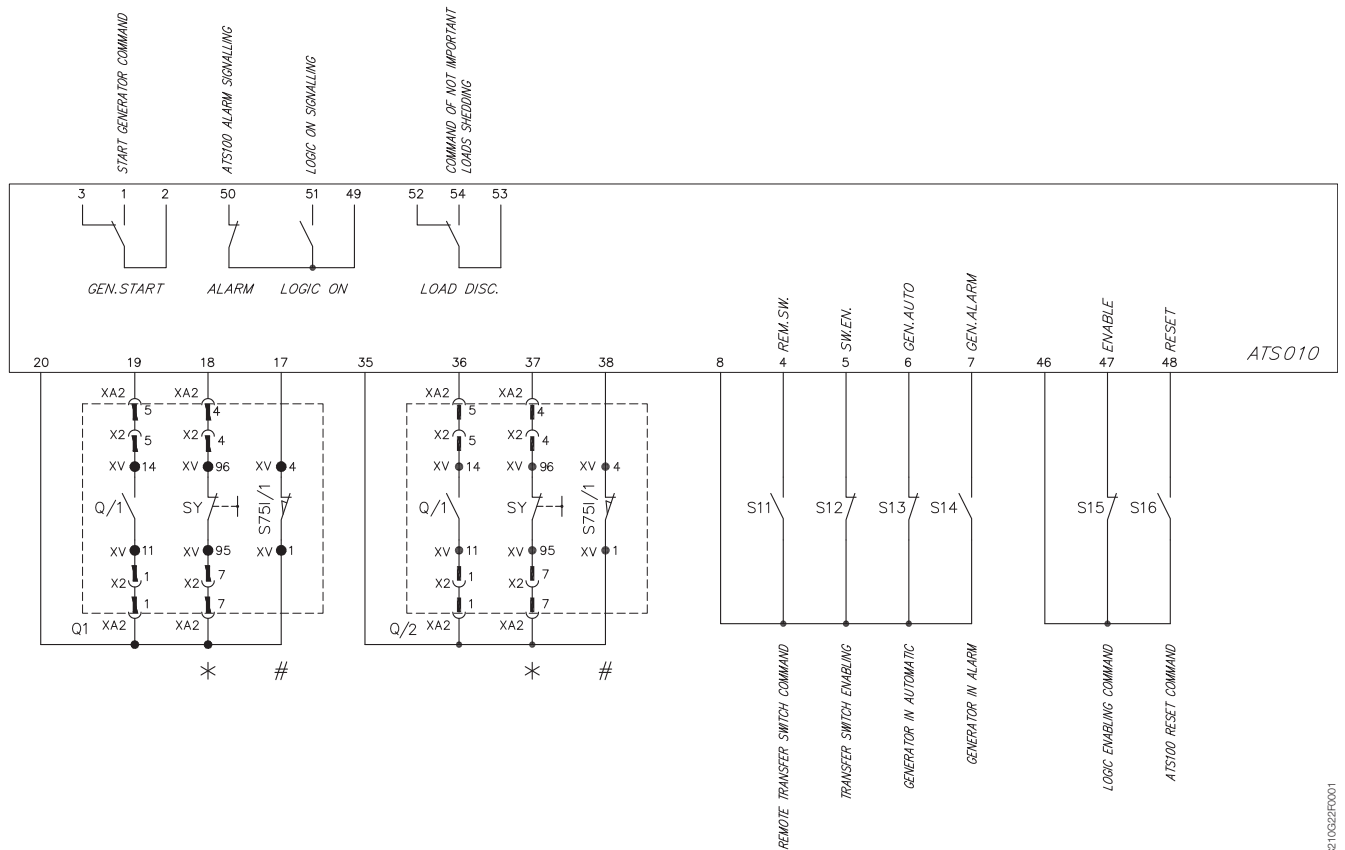

1SD0310622F0001

ATS010 device for the automatic transfer switch of two T4-T5-T6 circuit-breakers without safety auxiliary voltage supply

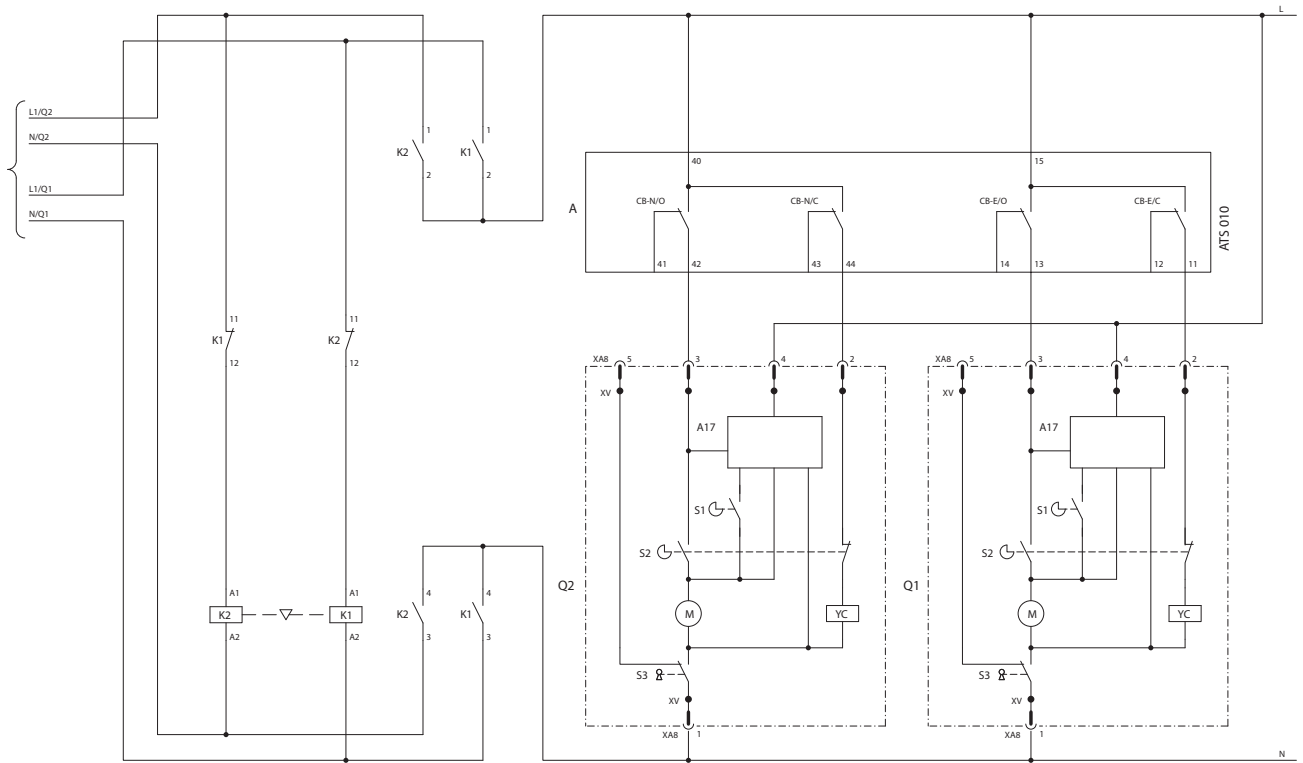

1SDC210023F0001

Wiring diagrams

Automatic transfer-switch ATS010 for T4-T5-T6

ATS010 device for the automatic transfer switch of two T4-T5-T6 circuit-breakers with safety auxiliary voltage supply in alternating current (AC)

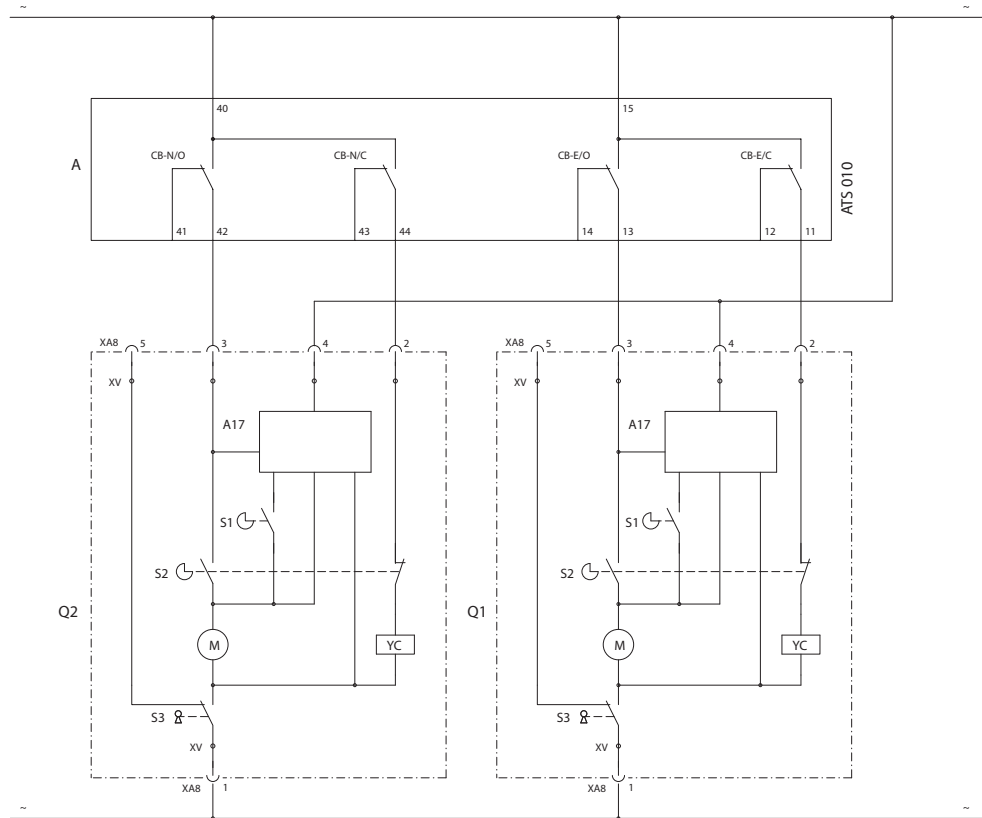

1SDC210C24FC001

ATS010 device for the automatic transfer switch of two T4-T5-T6 circuit-breakers with safety auxiliary voltage supply in direct current (DC)

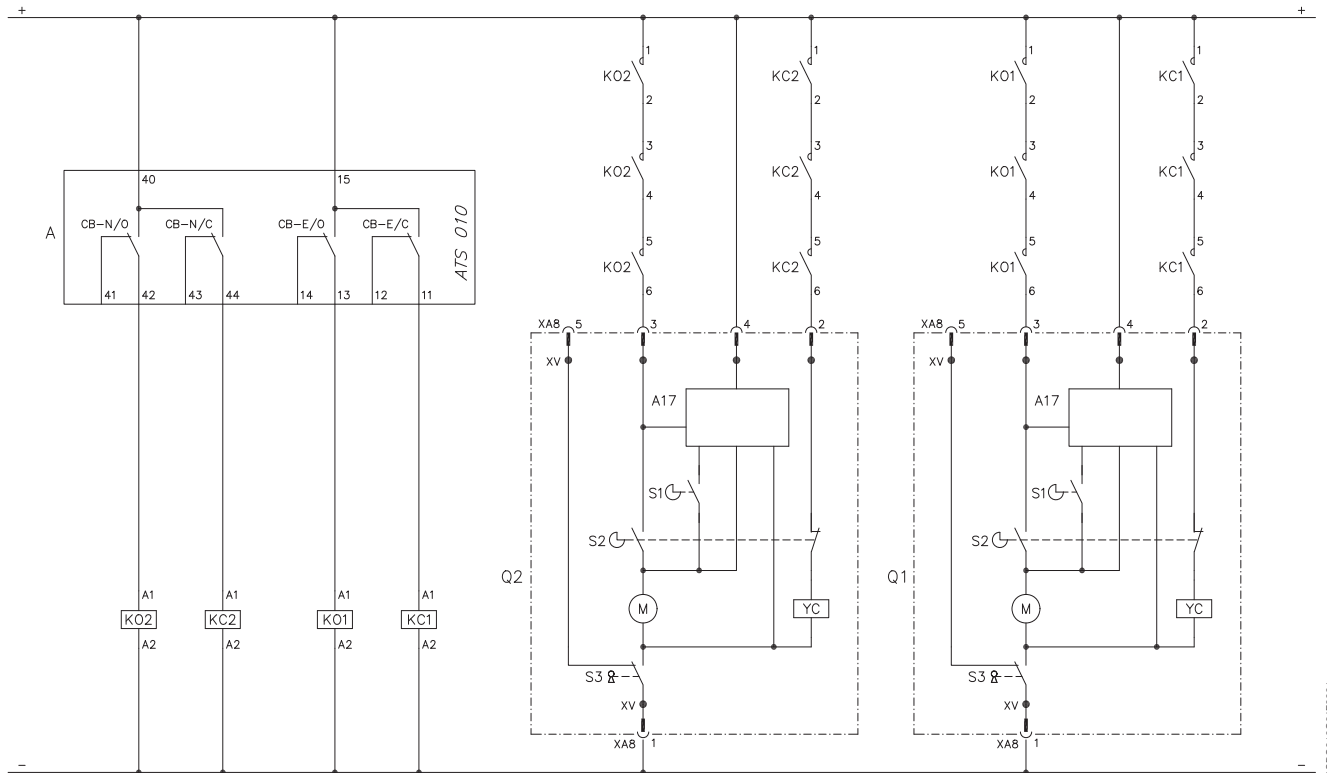

1SDC210034F0001

Wiring diagrams

Automatic transfer-switch ATS010 for T7

Automatic transfer-switch ATS010 for the automatic transfer switch of the two T7 circuit-breakers, without safety auxiliary voltage supply

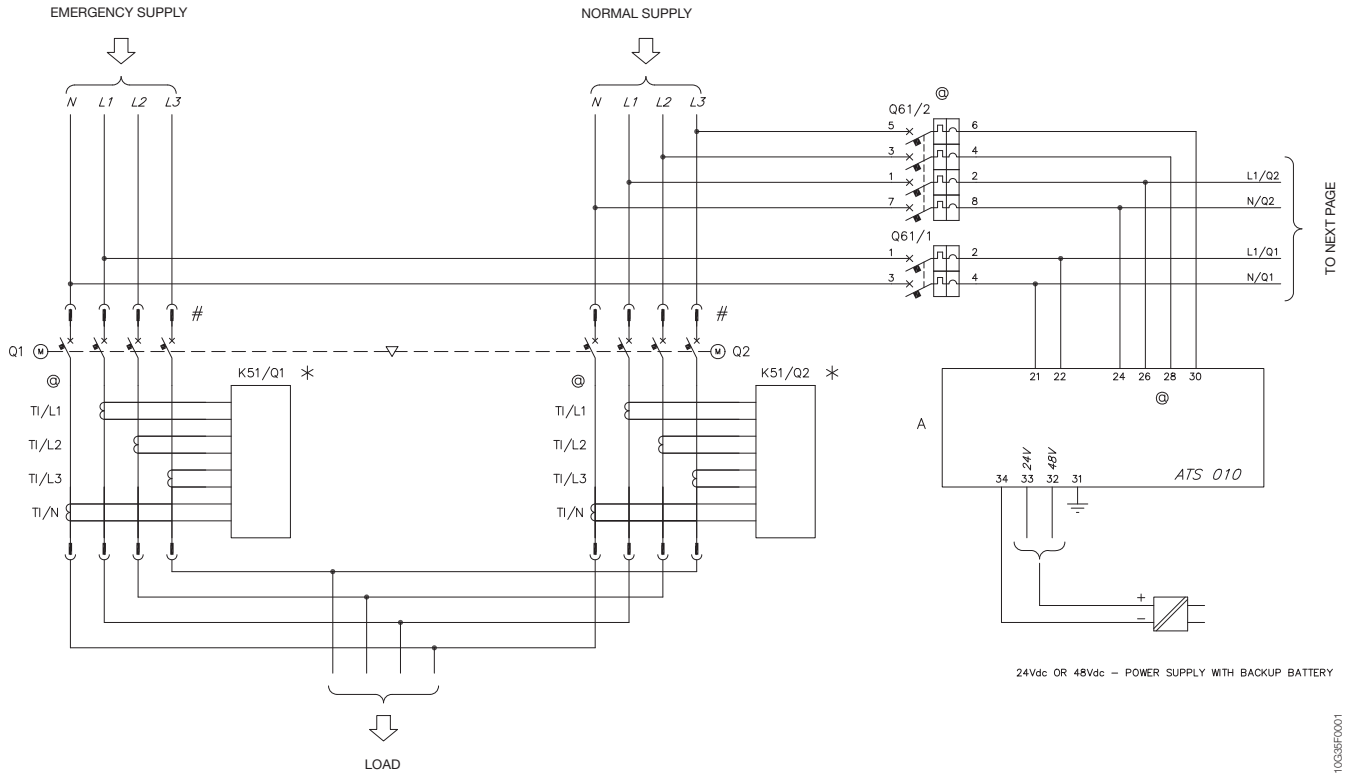

1SDC210G5BF0001

5

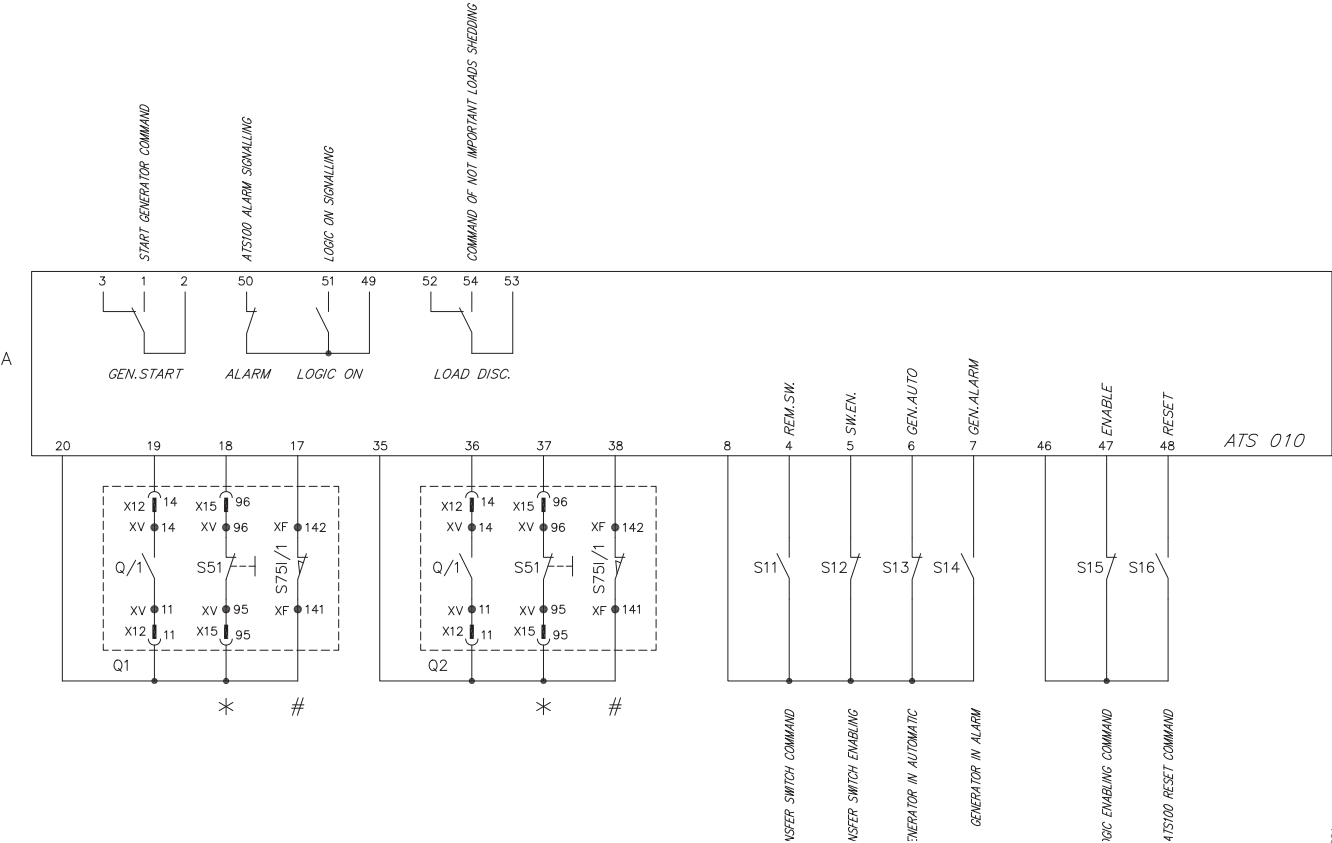

1SDC210G5BF0001

FROM PREVIOUS PAGE

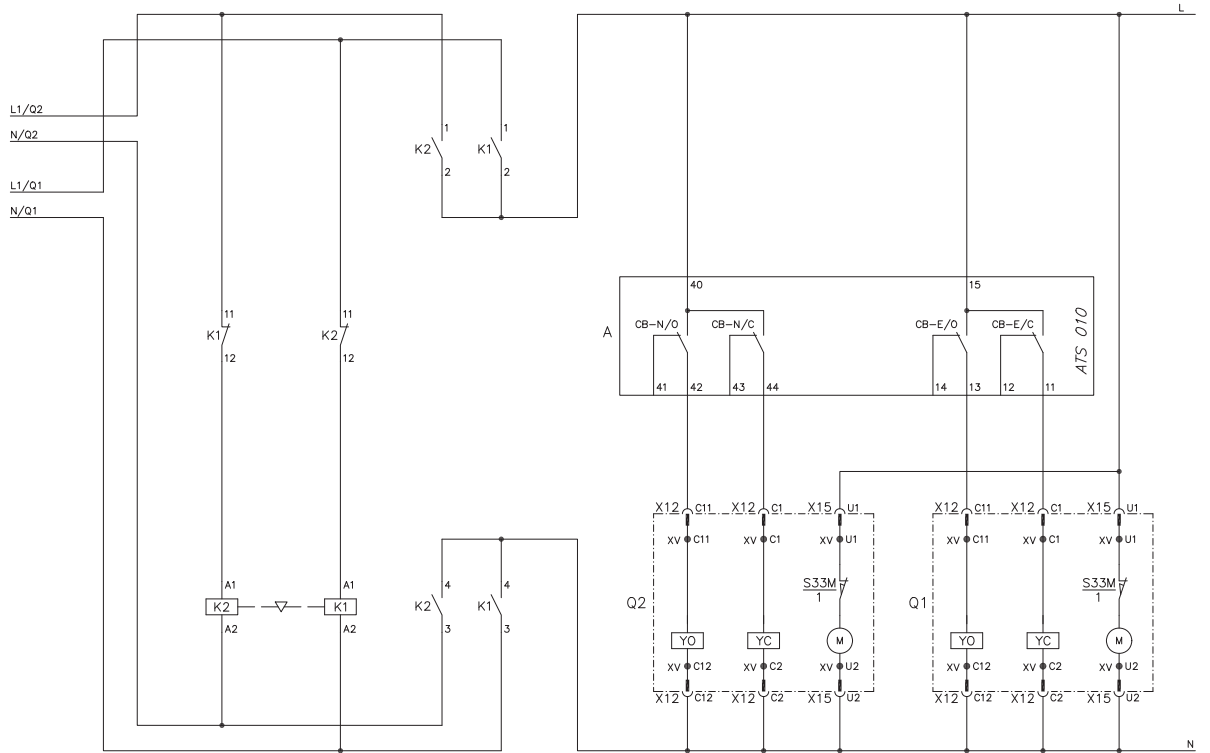

1SDC210028F0001

Wiring diagrams

Automatic transfer-switch ATS010 for T7

Automatic transfer-switch ATS010 for the automatic transfer switch of the two T7 circuit-breakers, with safety auxiliary voltage supply in alternating current (AC)

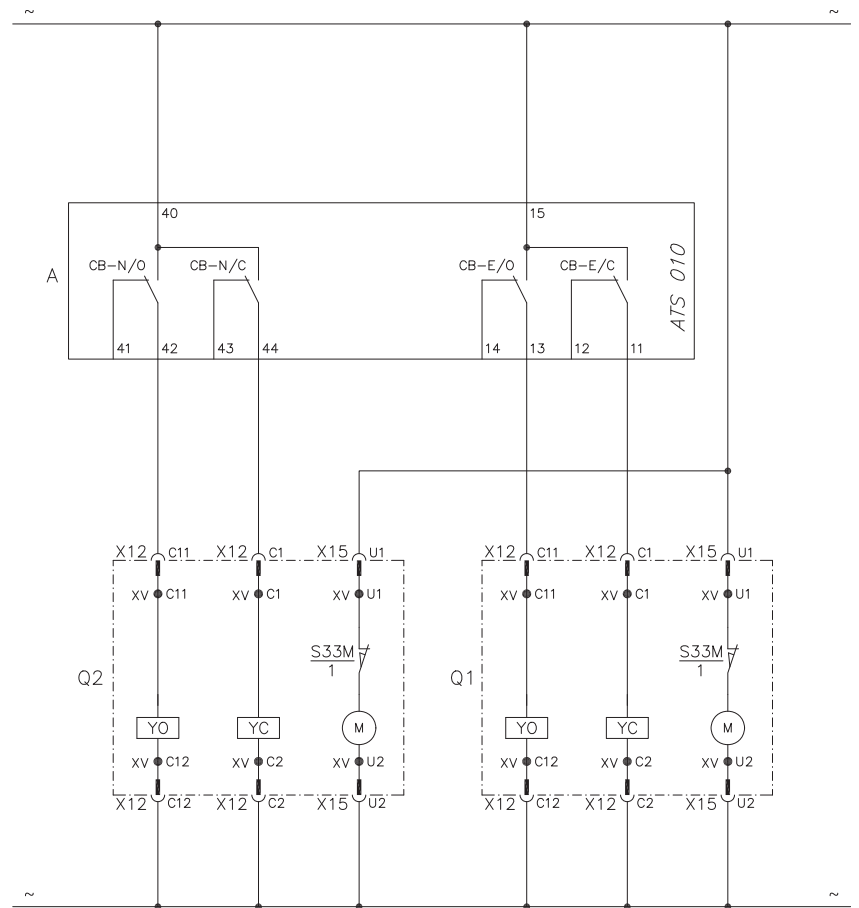

1SDC210G38F0001



Index

Fixed circuit-breaker and terminals

Tmax T1 and single-pole Tmax T1	6/2
Tmax T2	6/5
Tmax T3	6/8
Tmax T4	6/11
Tmax T5	6/14
Tmax T6	6/17
Tmax T7	6/22
Tmax T7M	6/27

Plug-in circuit-breaker and terminals

Tmax T2	6/32
Tmax T3	6/35
Tmax T4	6/38
Tmax T5	6/41

Withdrawable circuit-breaker and terminals

Tmax T4	6/44
Tmax T5	6/46
Tmax T6	6/49
Tmax T7	6/51
Tmax T7M	6/53
Circuit-breaker with RC221/222 residual current release	6/55

Accessories

Tmax T1 - T2 - T3	6/63
Tmax T4 - T5	6/70
Tmax T6	6/77
Tmax T7	6/83

Distances to be respected	6/88
---------------------------------	------

Overall dimensions

Tmax T1 and single-pole Tmax T1

Fixed circuit-breaker

Fixing on sheet

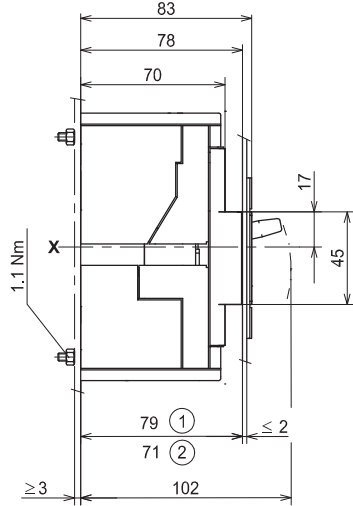
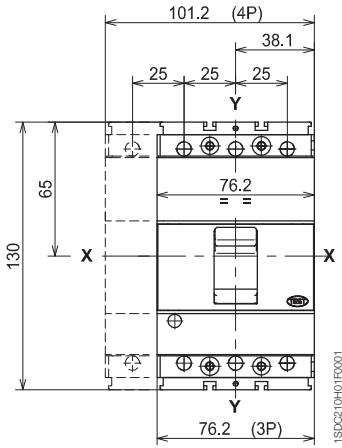

Fixing on DIN EN 50022 rail

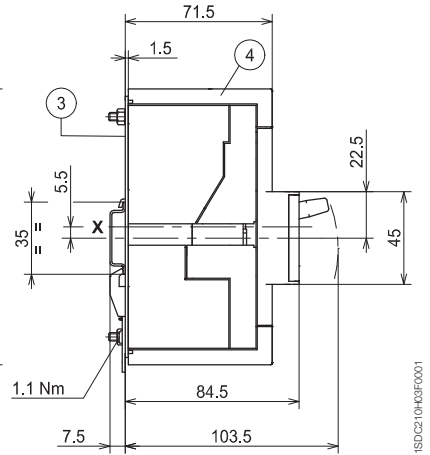
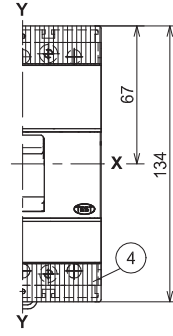

Without inserts

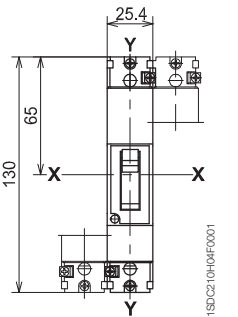

T1 1P (SINGLE-POLE)

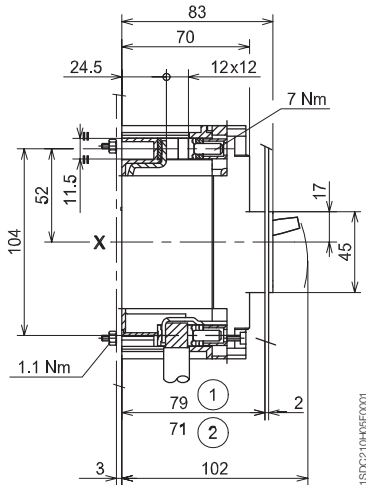

With inserts

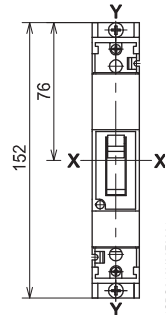

T1 1P (SINGLE-POLE)

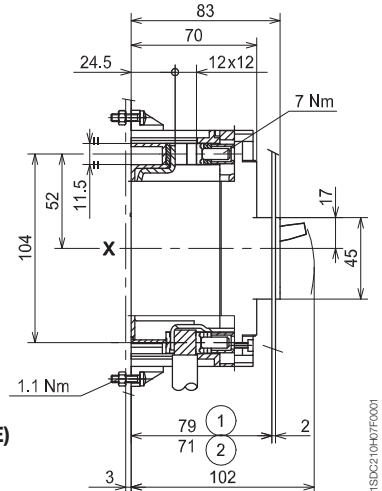

Caption

- ① Depth of the switchboard in the case of circuit-breaker with face not extending from the compartment door, with or without flange
- ② Depth of the switchboard in the case of circuit-breaker with face extending from the compartment door, without flange
- ③ Bracket for fixing onto rail
- ④ Bottom terminal covers with IP40 degree of protection

Drilling templates for support sheet

For front terminals

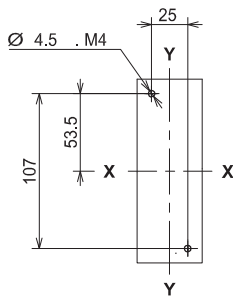

3 POLES

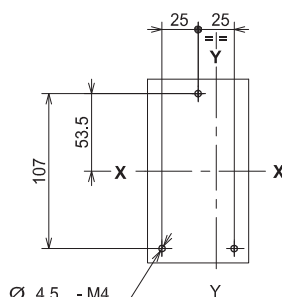

4 POLES

Without inserts

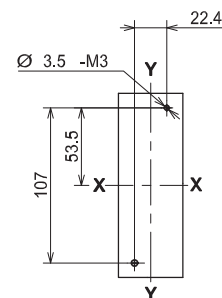

T1 1P (SINGLE-POLE)

With inserts

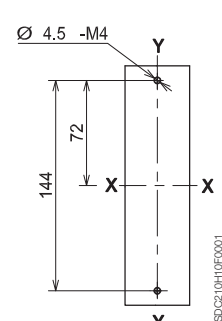

Terminals

Front for copper/aluminium cables - FC CuAl

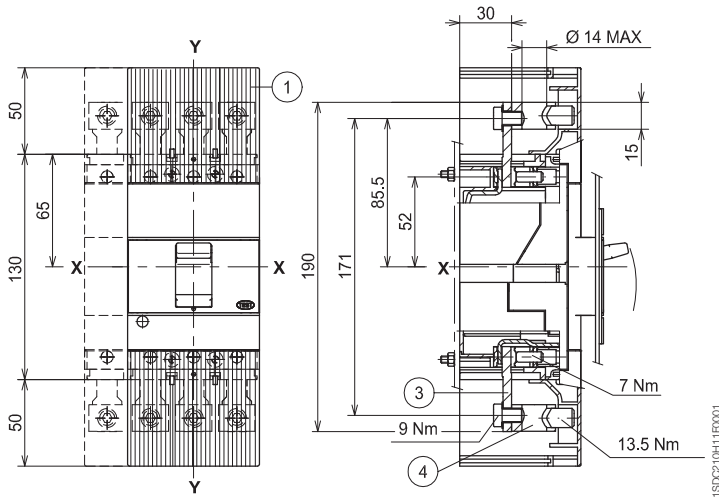

Front extended - EF

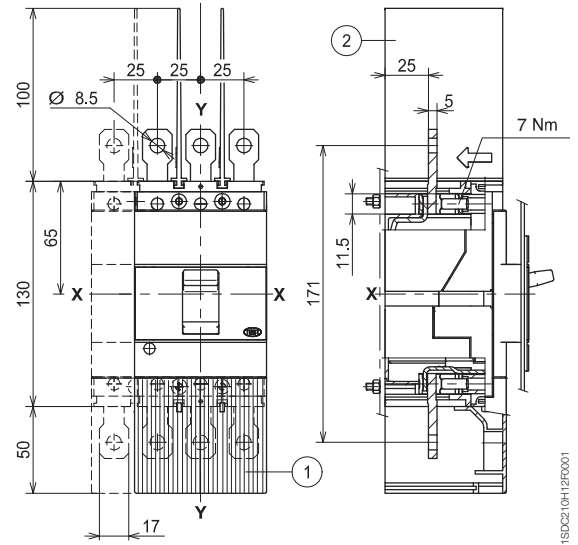

Rear flat horizontal - HR

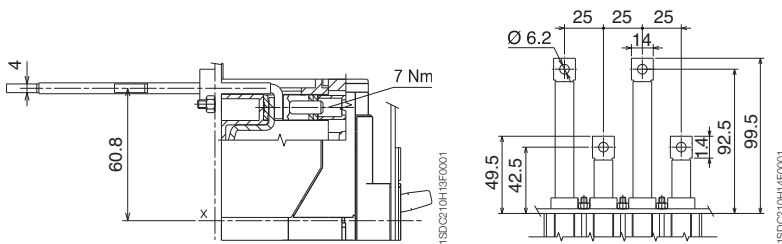

Front for copper cables - FC Cu

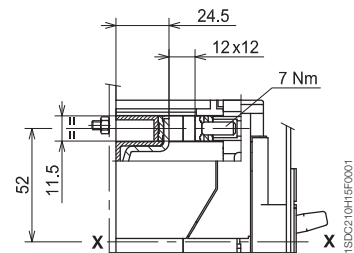

Caption

- ① High terminal covers with IP40 degree of protection (compulsory)
- ② Insulating barriers between phases (compulsory in the absence of top terminal covers)
- ③ Front extended terminals
- ④ Terminals for CuAl cables 95 mm²

Front for copper/aluminum cables - FC CuAl 50 mm²

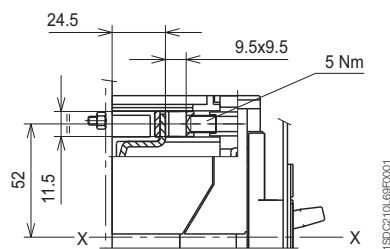

Overall dimensions

Tmax T1 and single-pole Tmax T1

Terminals

Flange for the compartment door

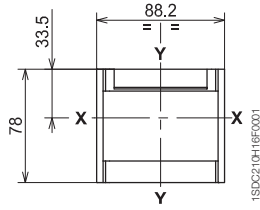

Drilling templates of the compartment door

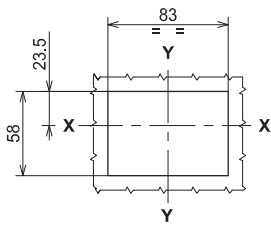

With flange and circuit-breaker face flush with door (3-4 POLES)

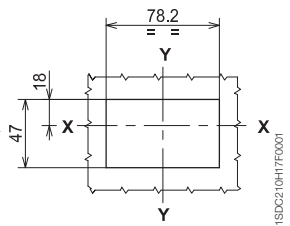

Without flange and circuit-breaker face flush with door (3-4 POLES) or extending (3 POLES)

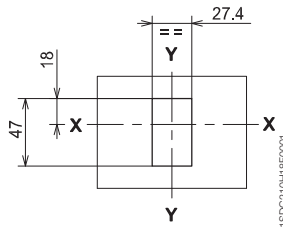

(SINGLE-POLE)

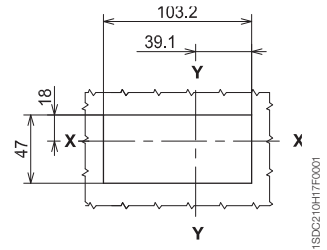

Without flange and circuit-breaker face extending (4 POLES)

Drilling templates for support sheet

For rear terminals

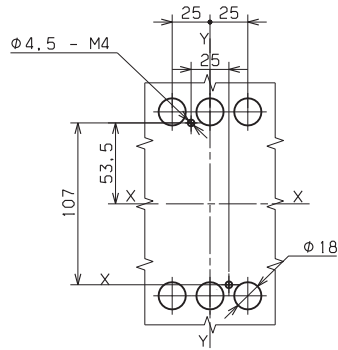

3 POLES

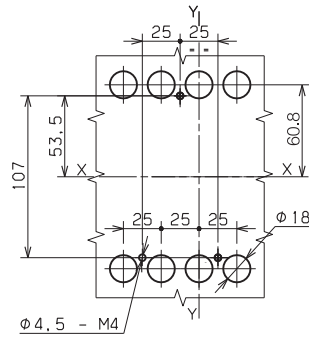

4 POLES

Overall dimensions

Tmax T2

Fixed circuit-breaker

Fixing on sheet

Fixing on DIN EN 50022 rail

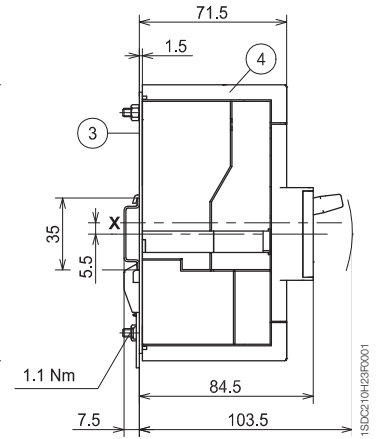
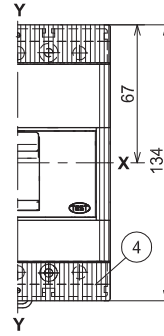
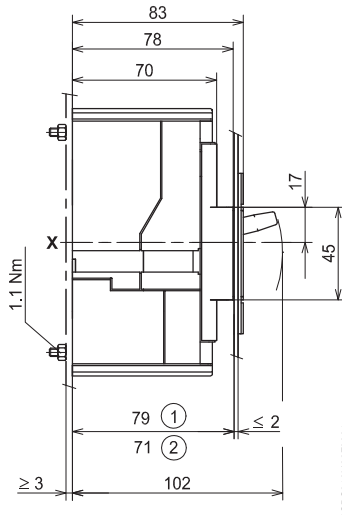
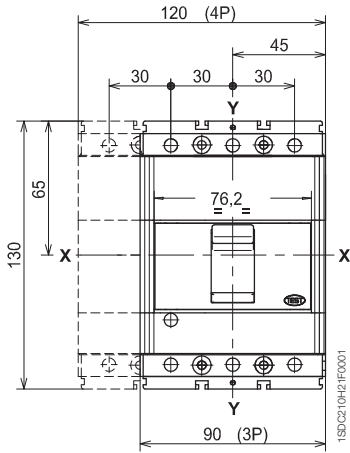

Flange for the compartment door

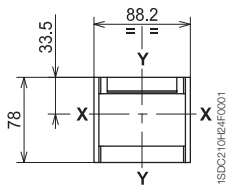

Drilling templates of the compartment door

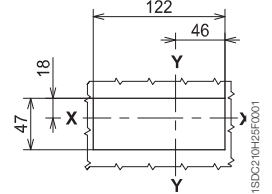
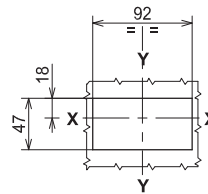
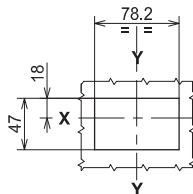
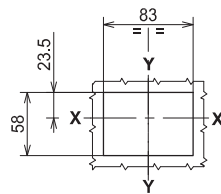

With flange and circuit-breaker face flush with door (3-4 POLES)

Without flange and circuit-breaker face flush with door (3-4 POLES)

Without flange and circuit-breaker face extending (3 POLES)

Without flange and circuit-breaker face extending (4 POLES)

Caption

- ① Depth of the switchboard in the case of circuit-breaker with face not extending from the compartment door, with or without flange
- ② Depth of the switchboard in the case of circuit-breaker with face extending from the compartment door, without flange
- ③ Bracket for fixing onto rail
- ④ Low terminal covers with degree of protection IP40

Drilling templates for support sheet

For front terminals

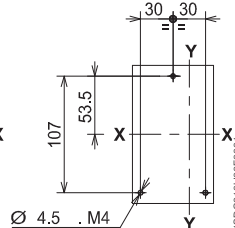
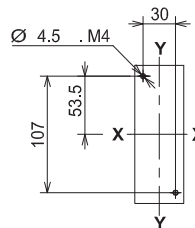

3 POLES

4 POLES

For rear terminals

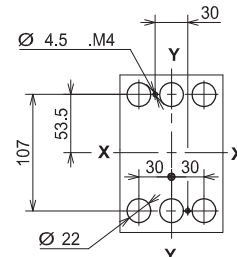

3 POLES

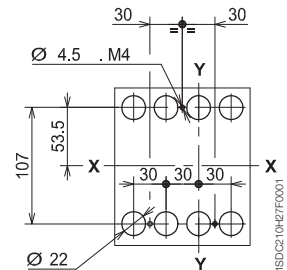

4 POLES

Overall dimensions

Tmax T2

Terminals

Front - F

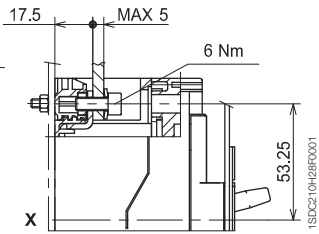
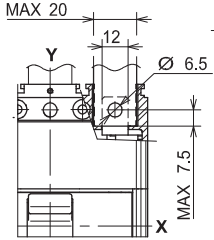

Front for copper cables - FC Cu

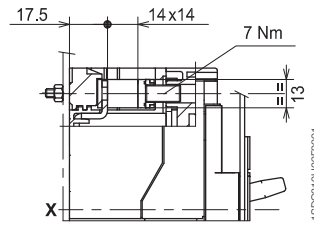

Front for copper/aluminium cables - FC CuAl 95 mm²

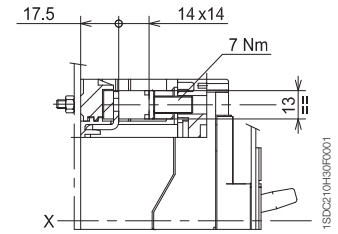

Caption

- ① Front extended terminals
- ② Front terminals for cables 185 mm² CuAl
- ③ Insulating court plate (compulsory)
- ④ High terminal covers with degree of protection IP40 (compulsory)
- ⑤ Drilling templates for support sheet

Front for copper/aluminium cables - FC CuAl 185 mm²

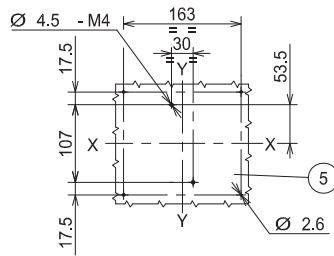
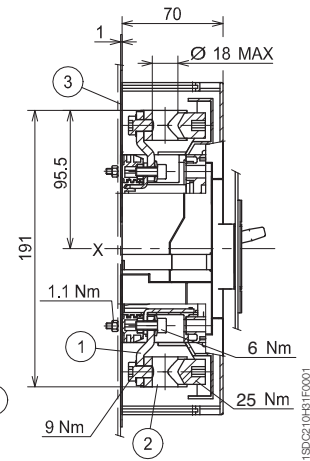
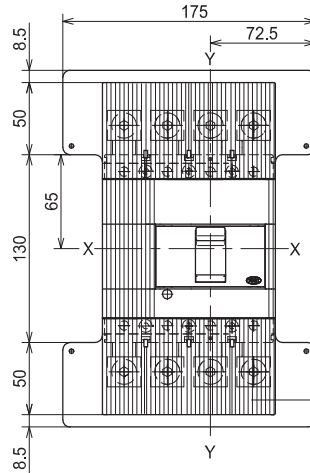
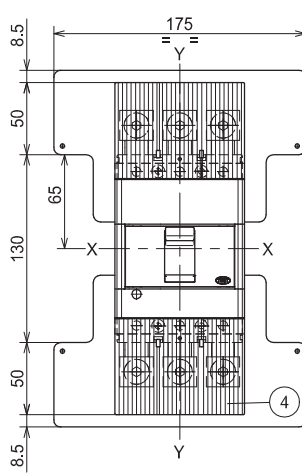

3 POLES

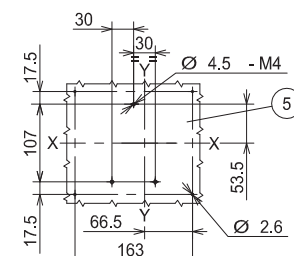

4 POLES

Caption

- ① Insulating barriers between phases (compulsory)

Front extended spread - ES

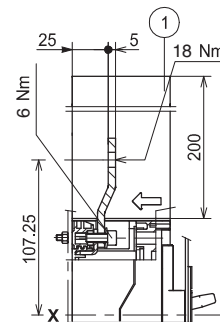
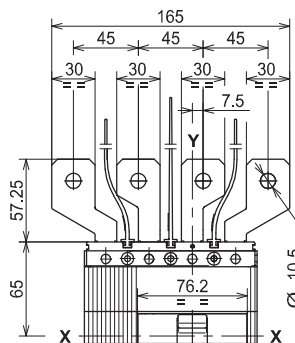
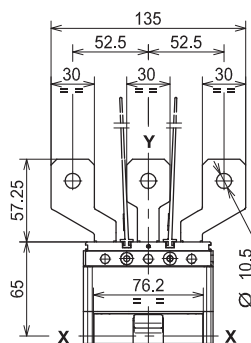

Caption

Front extended - EF

- ① High terminal covers with degree of protection IP40
- ② Insulating barriers between phases (compulsory without 1)

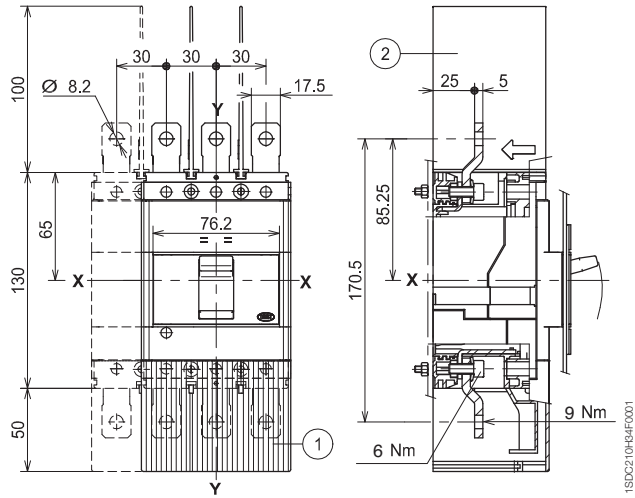

Caption

Rear horizontal - R

- ① Low terminal covers with degree of protection IP40

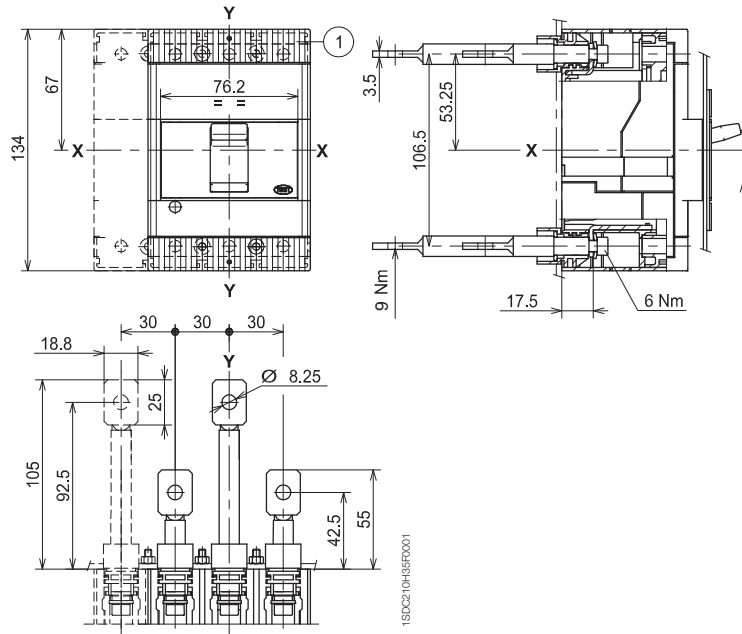

Overall dimensions

Tmax T3

Fixed circuit-breaker

Fixing on sheet

Fixing on DIN EN 50022 rail

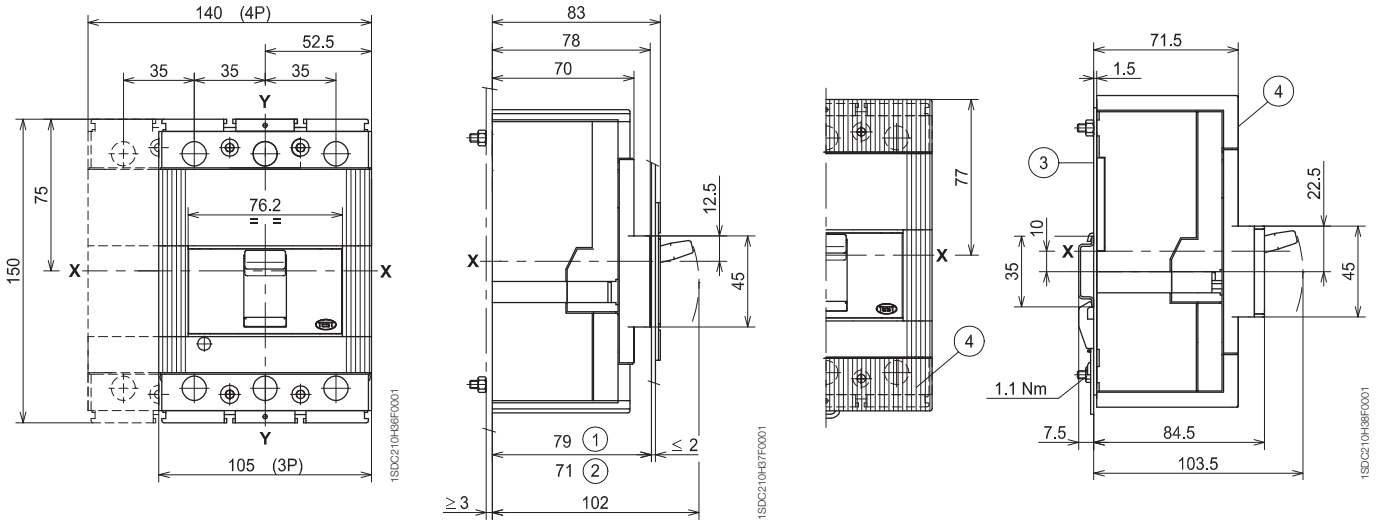

Caption

- ① Depth of the switchboard in the case of circuit-breaker with face not extending from the compartment door, with or without flange
- ② Depth of the switchboard in the case of circuit-breaker with face extending from the compartment door
- ③ Bracket for fixing on rail
- ④ Low terminal covers with degree of protection IP40

Flange for compartment door

Drilling templates of the compartment door

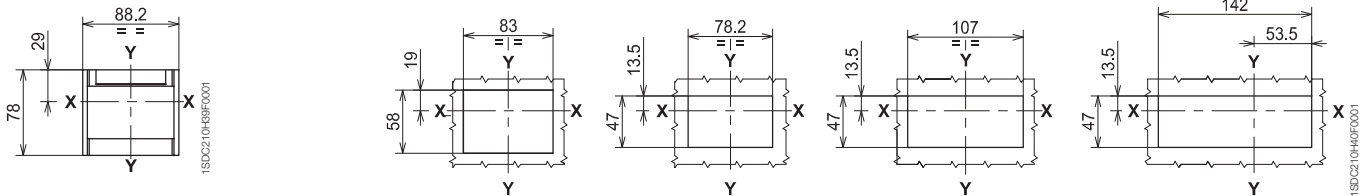

With flange and circuit-breaker face flush with door (3-4 POLES)

Without flange and circuit-breaker face flush with door (3-4 POLES)

Without flange and circuit-breaker face extending (3 POLES)

Without flange and circuit-breaker face extending (4 POLES)

Drilling templates for support sheet

For front terminals

For rear terminals

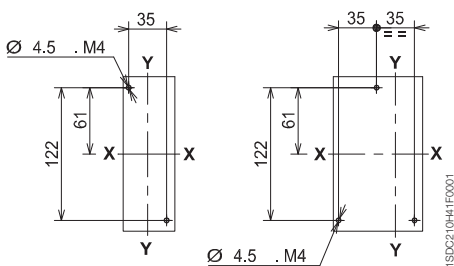

3 POLES

4 POLES

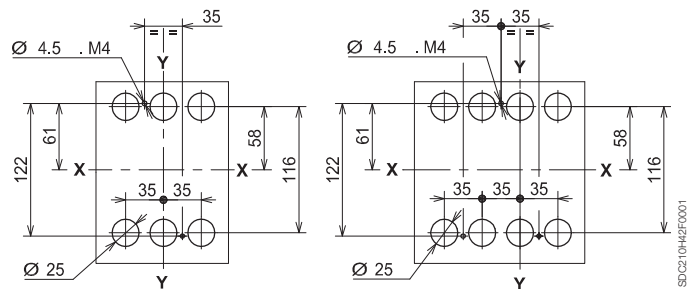

3 POLES

4 POLES

Terminals

Front - F

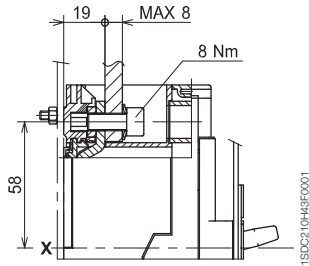
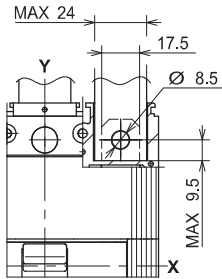

Front for copper cables - FC Cu

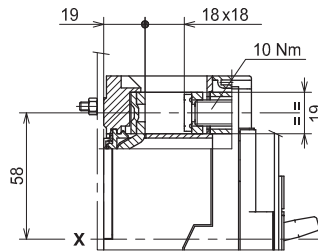

Front for copper/aluminium cables - FC CuAl 185 mm²

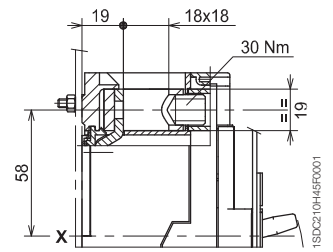

Caption

- ① Front extended terminals
- ② Front terminals for cables 240 mm² CuAl
- ③ Insulating course plate (compulsory)
- ④ High terminal covers with degree of protection IP40 (compulsory)
- ⑤ Drilling templates for support sheet

Front for copper/aluminium cables - FC CuAl 240 mm²

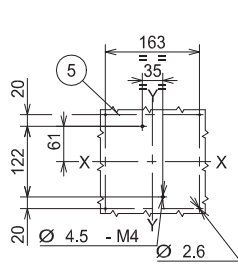
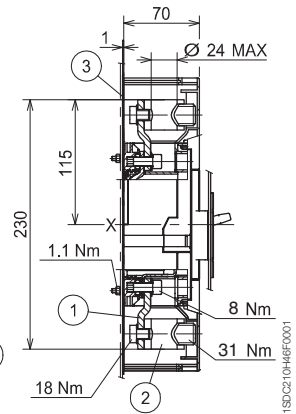
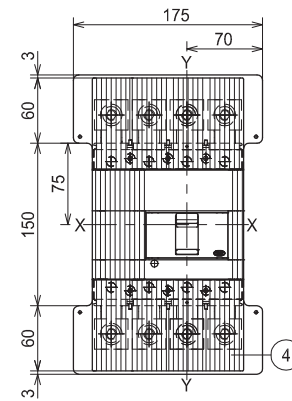
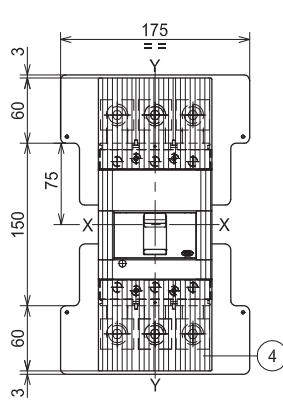

3 POLES

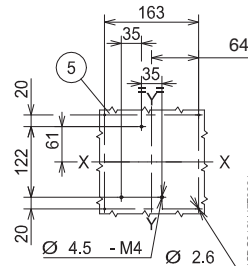

4 POLES

Caption

- ① Insulating barriers between phases (compulsory)

Front extended spread - ES

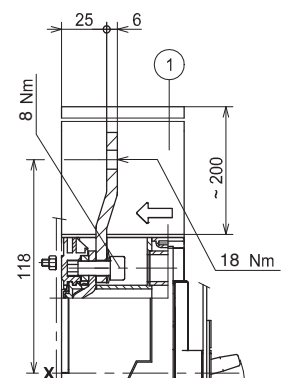
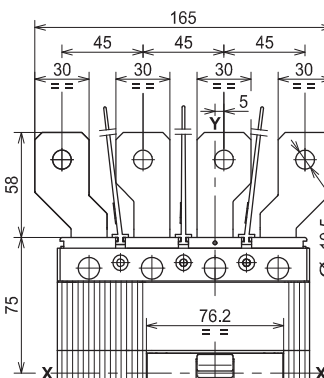
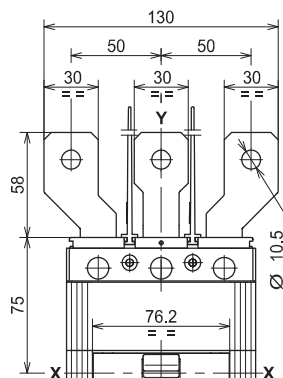

Overall dimensions

Tmax T3

Terminals

Caption

- ① High terminal covers with degree of protection IP40
- ② Insulating barriers between phases (compulsory without 1)

Front extended - EF

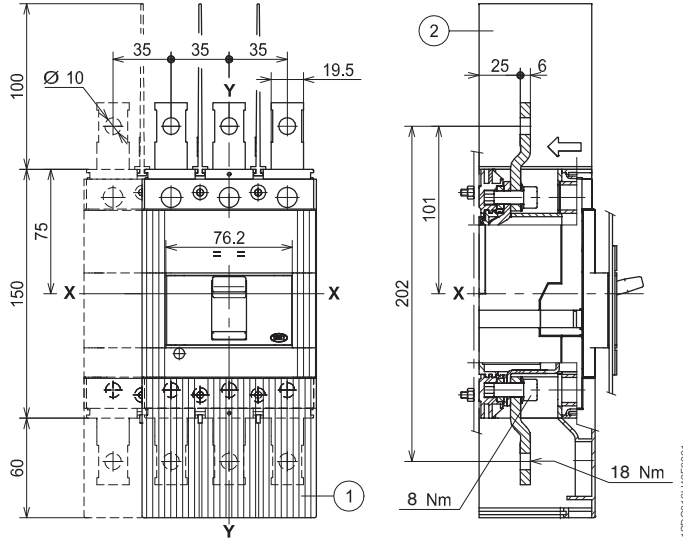

Caption

- ① Low terminal covers with degree of protection IP40

Rear horizontal - R

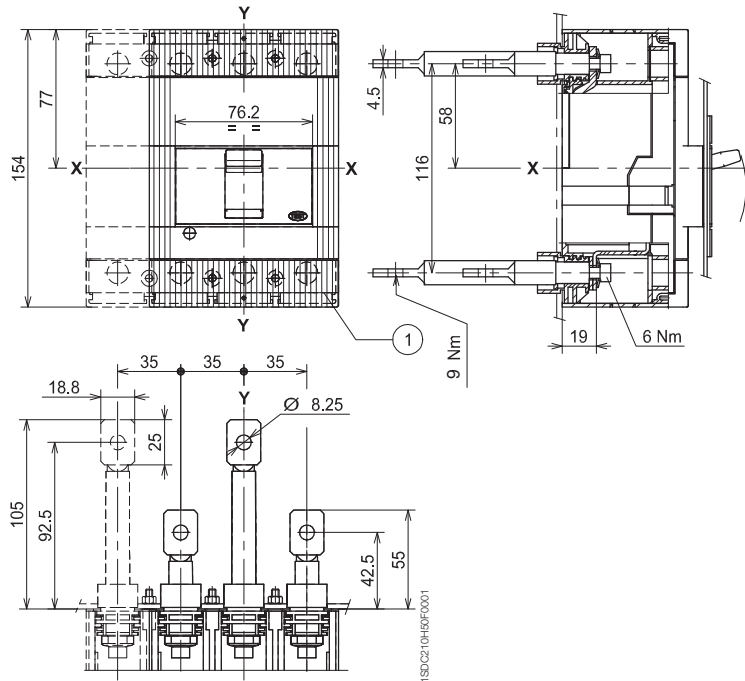

Overall dimensions

Tmax T4

Fixed circuit-breaker

Caption

Fixing on sheet

- ① Overall dimensions with cabled accessories mounted (SOR-C, UVR-C, RC222-223)
- ② Overall dimensions with cabled auxiliary contacts mounted (only 3Q 1SY)

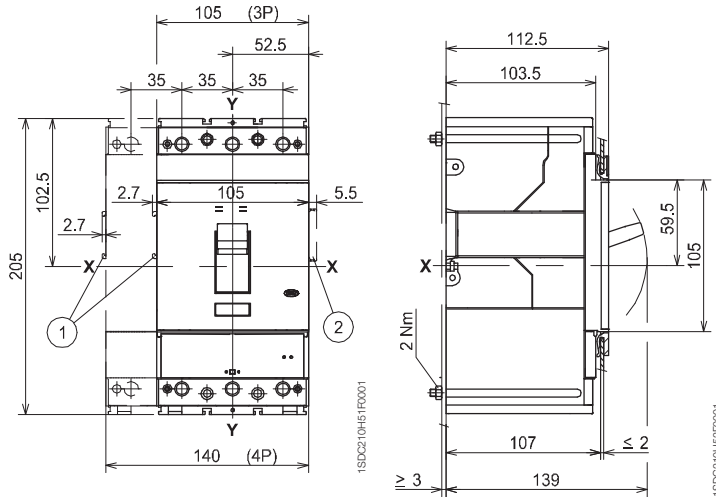

Flange for compartment door

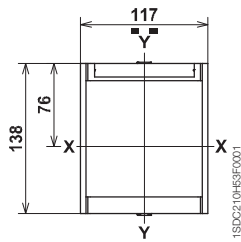

Drilling templates of the compartment door

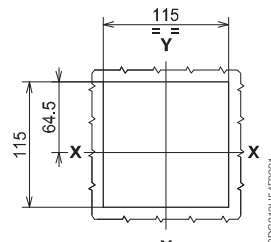

3-4 POLES
With flange

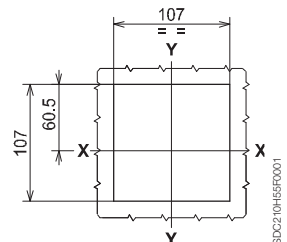

3-4 POLES
Without flange

Drilling templates for support sheet

For front terminals

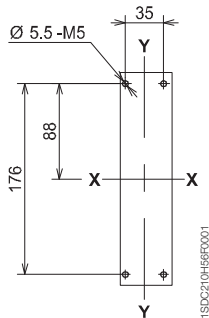

3 POLES

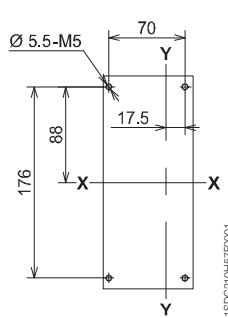

4 POLES

For rear terminals

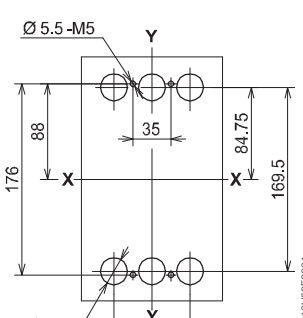

3 POLES

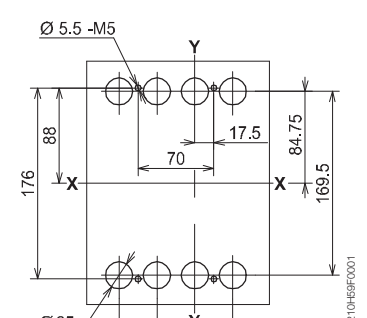

4 POLES

Overall dimensions

Tmax T4

Terminals

Front - F

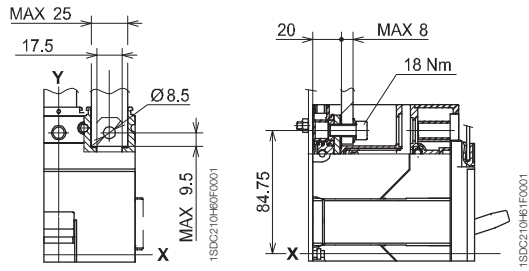

Front for copper cables - FC Cu

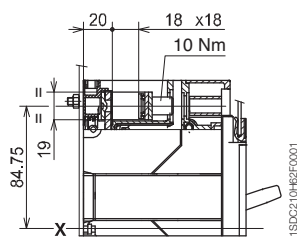

Front for copper/aluminium cables - FC CuAl

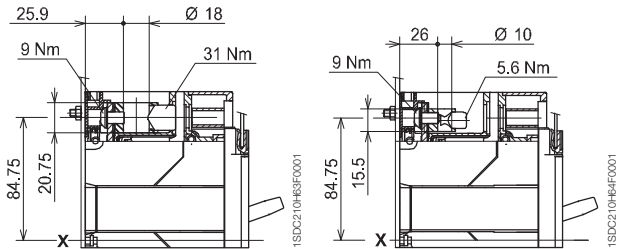

Caption

- ① Front terminals for cable connection 2x150 mm²
- ② Front terminals for multicable connection
- ③ High terminal covers with degree of protection IP40

Front multicable - MC

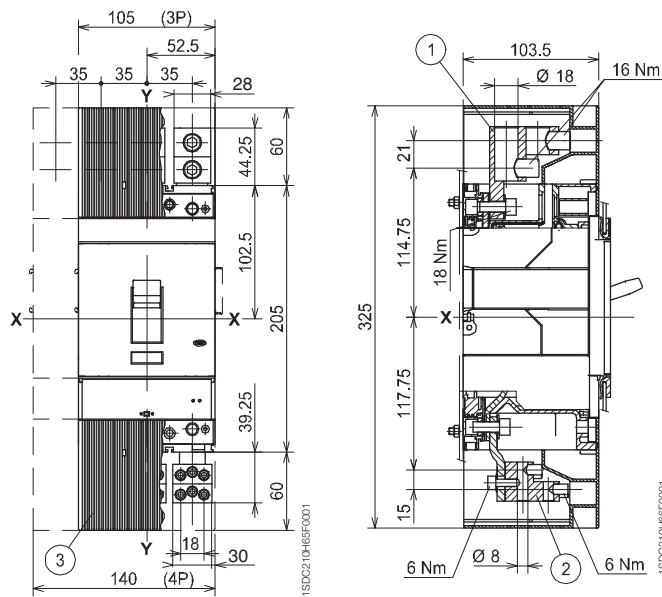

Caption

- ① Insulating barriers between phases (compulsory)

Front extended spread - ES

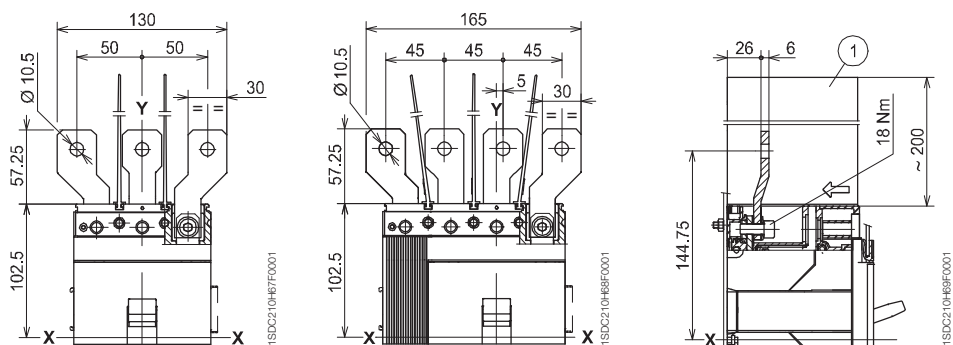

Overall dimensions

Tmax T5

Fixed circuit-breaker Fixing on sheet

Caption

- ① Overall dimensions with cabled accessories mounted (SOR-C, UVR-C, RC222)
- ② Overall dimensions with cabled auxiliary contacts mounted (only 3Q 1SY)

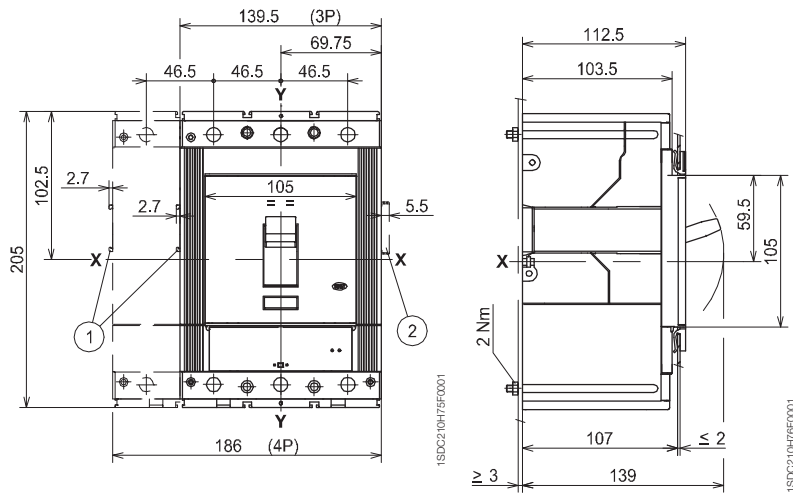

Flange for compartment door

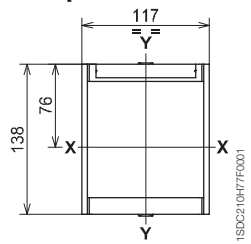

Drilling templates of the compartment door

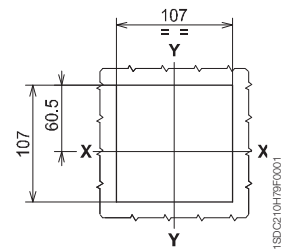
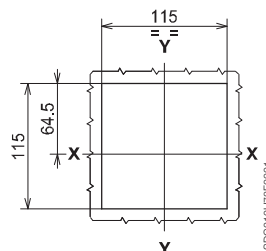

With flange (3-4 POLES)

Without flange (3-4 POLES)

Drilling templates for support sheet

For front terminals

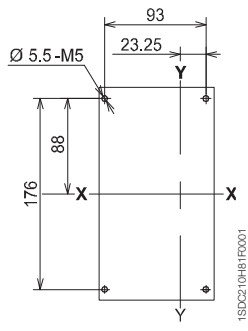
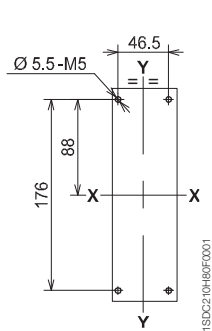

For rear terminals

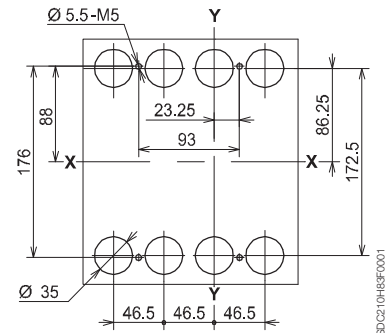
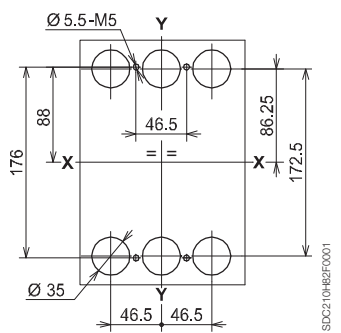

3 POLES

4 POLES

3 POLES

4 POLES

Terminals

Front - F

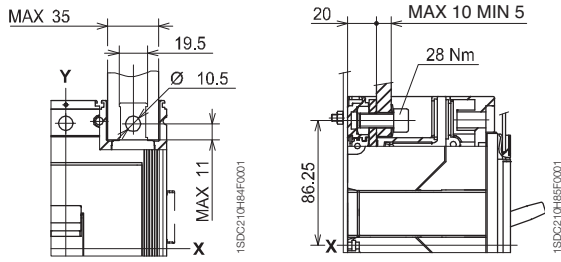

Front for copper cables - FC Cu

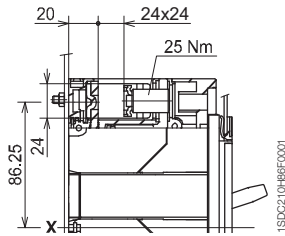

Front for copper cables - FC Cu 2x240 mm²

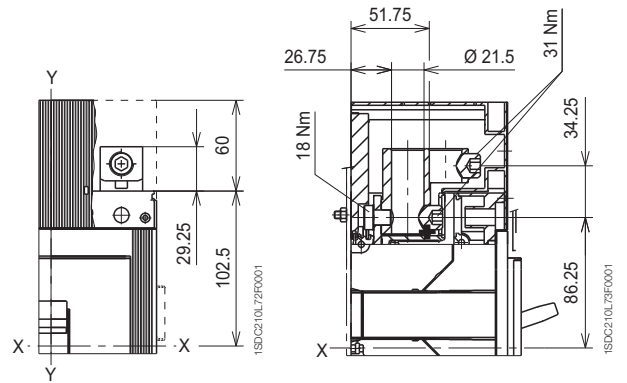

Front for copper/aluminum cables - FC CuAl 2x120 mm²

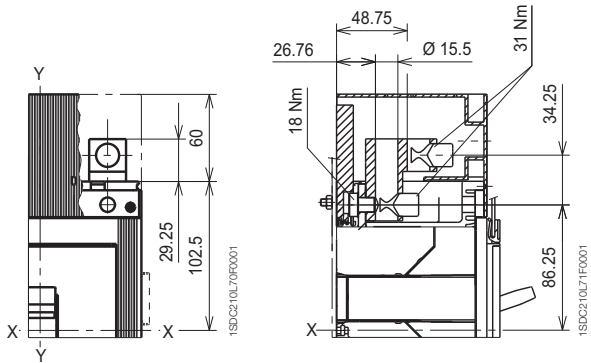

Front for copper/aluminum cables - FC CuAl 1x240 mm²

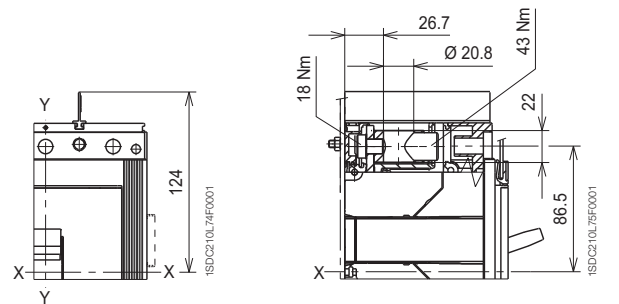

Caption

- ① High terminal covers with degree of protection IP40

Front for copper/aluminium cables - FC CuAl 300 mm²

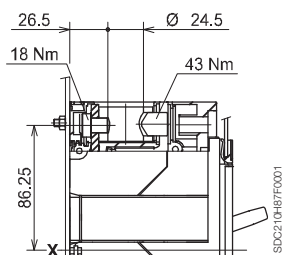

Front for copper/aluminium cables - FC CuAl 2x240 mm²

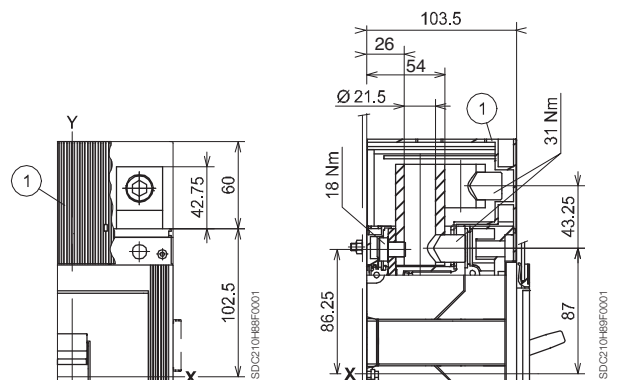

Overall dimensions

Tmax T5

Terminals

Caption

Front extended spread - ES

- ① Insulating barriers between phases (compulsory)

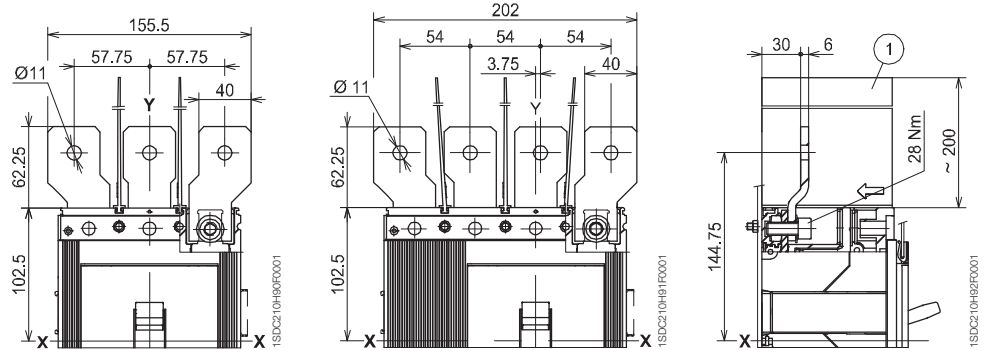

Caption

Front extended - EF

- ① High terminal covers with degree of protection IP40
- ② Insulating barriers between phases (compulsory without 1)

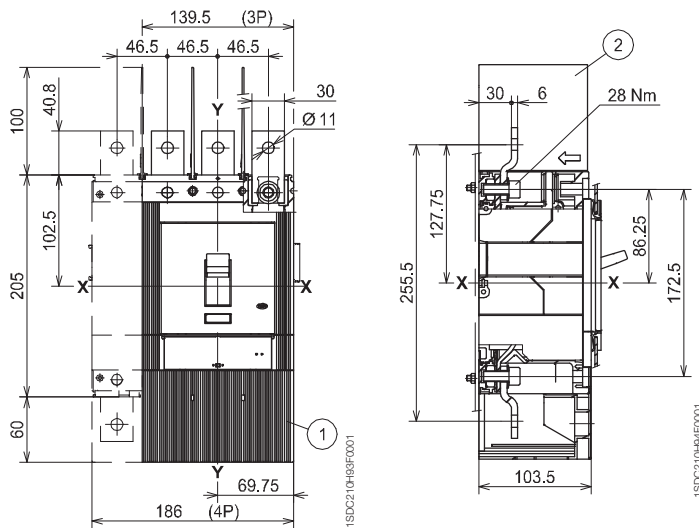

Rear horizontal - R

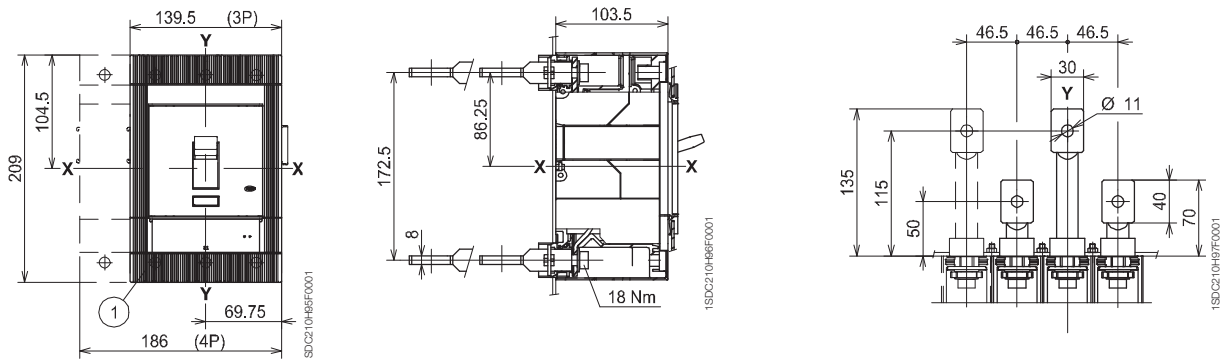

Caption

- ① Low terminal covers with degree of protection IP40

Overall dimensions

Tmax T6

Fixed circuit-breaker Fixing on sheet

Caption

- ① Overall dimensions with cabled accessories mounted (SOR-C, UVR-C)
- ② Overall dimensions with cabled auxiliary contacts mounted (only 3Q 1SY)

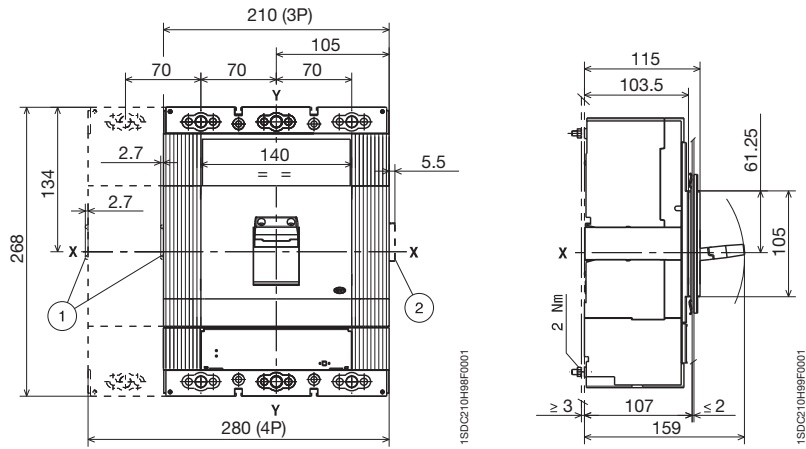

Flange for the compartment door

Drilling templates of the compartment door

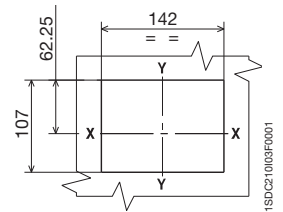
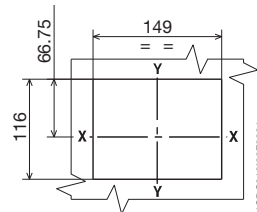
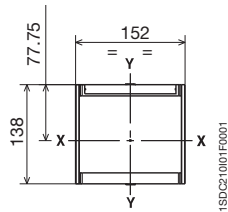

With flange 3-4 POLES

Without flange 3-4 POLES

Drilling templates for support sheet

For front terminals F, EF, ES, FC Cu, FC CuAl

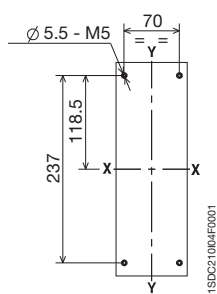

3 POLES

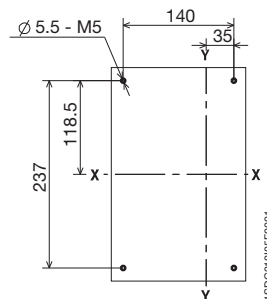

4 POLES

Overall dimensions

Tmax T6

Fixed circuit-breaker Drilling templates for support sheet

For rear terminals for copper/aluminium cables - RC CuAl

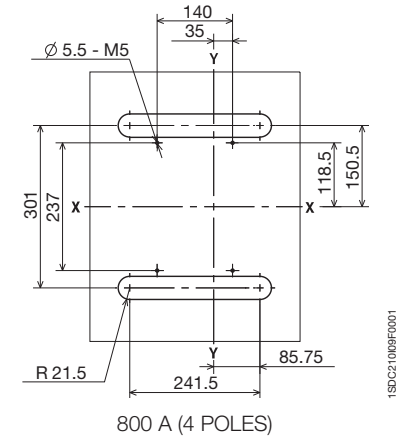
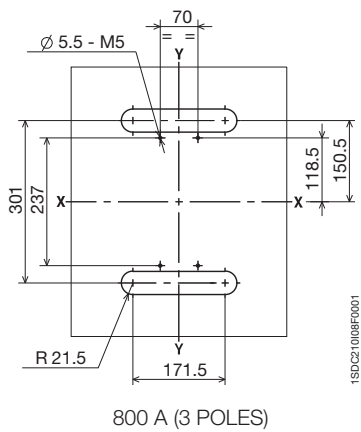
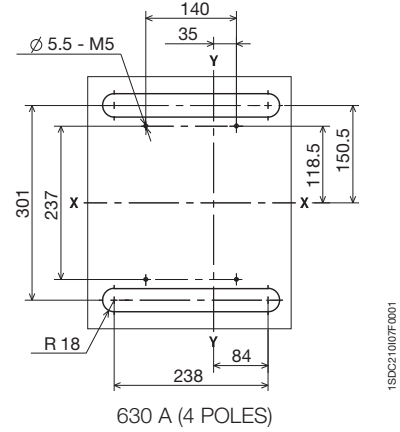
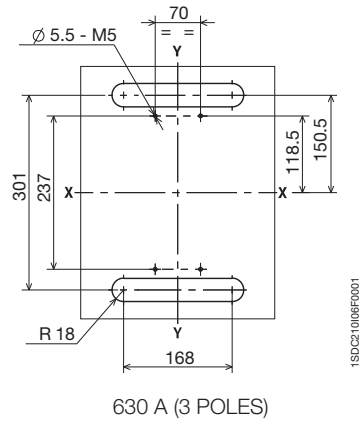

For rear terminals - R

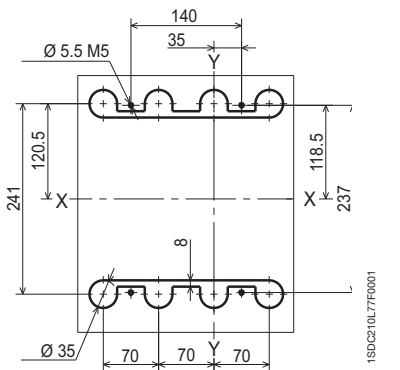
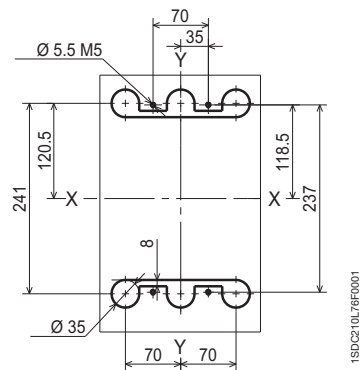

Terminals

Front - F

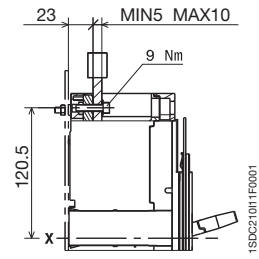
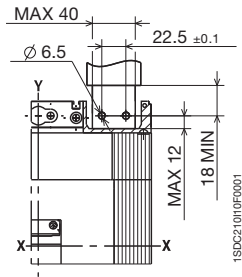

Front for copper/aluminium cables - FC CuAl 2x240 mm²

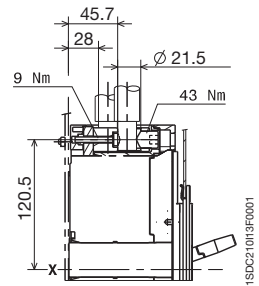
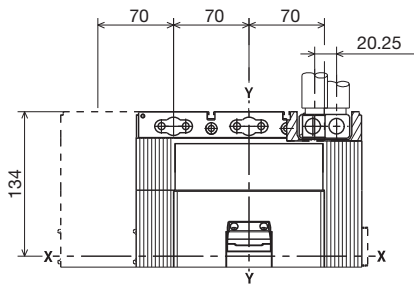

630 A

Front for copper/aluminium cables - FC CuAl 3x185 mm²

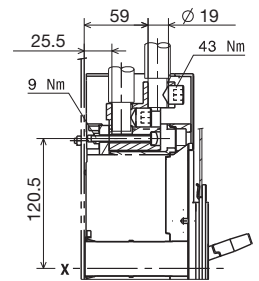
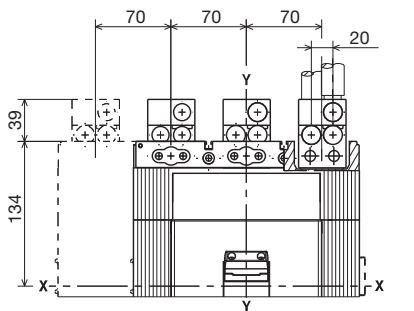

800 A

Front for copper/aluminium cables - FC CuAl 4x150 mm²

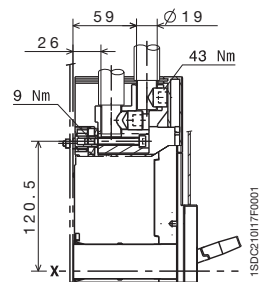
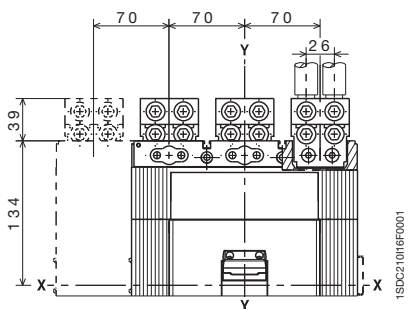

1000 A

Overall dimensions

Tmax T6

Terminals

Front extended - EF

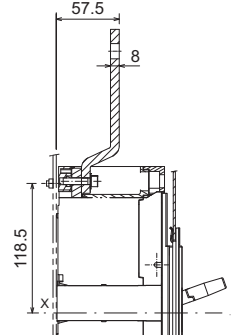
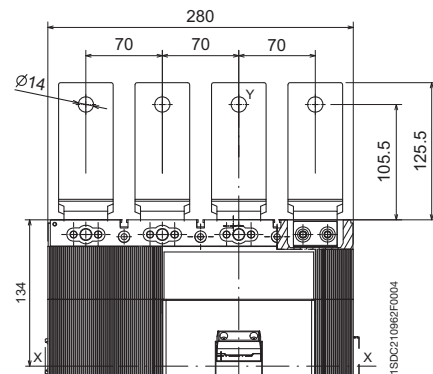
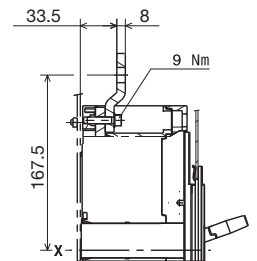
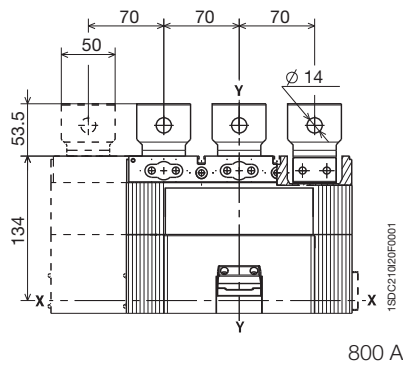
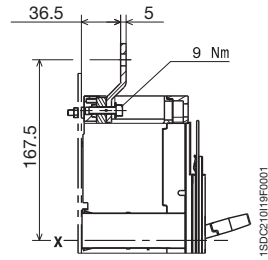
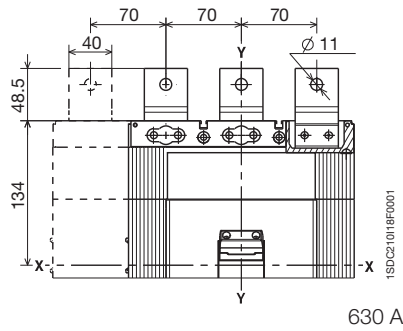

1000 A

Caption

- ① Insulating barriers between phases (compulsory)

Front extended spread - ES

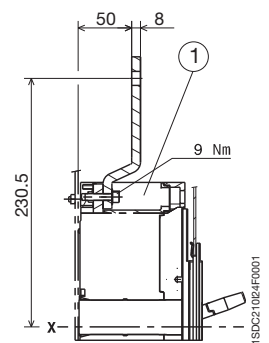
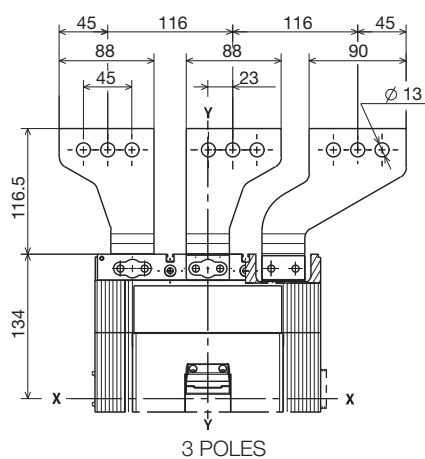
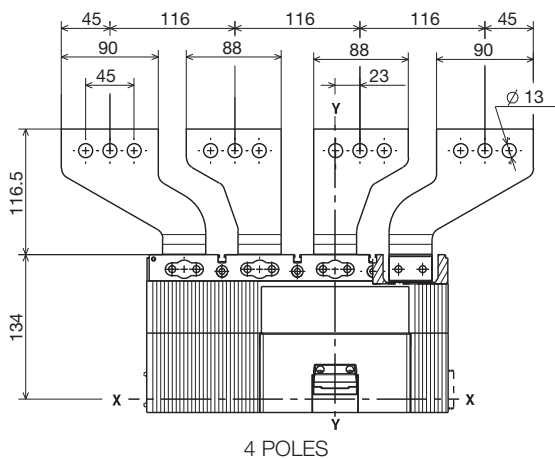

Rear for copper/aluminium cables - RC CuAl

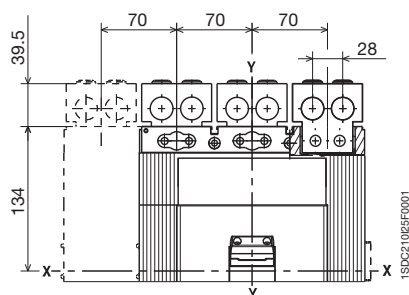

1SDC21025F0001

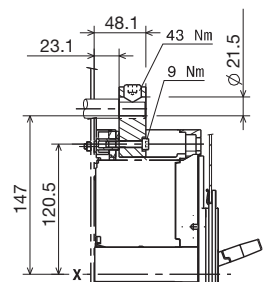

1SDC21026F0001

630 A

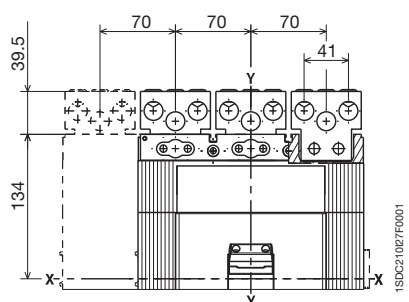

1SDC21027F0001

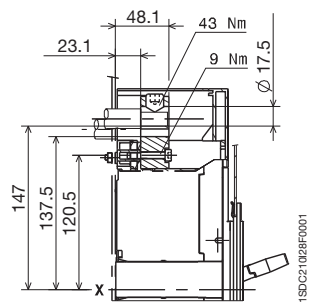

1SDC21028F0001

800 A

Rear horizontal - R

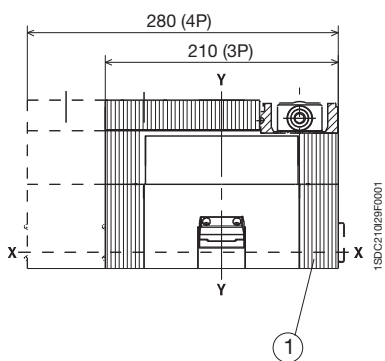

1SDC21029F0001

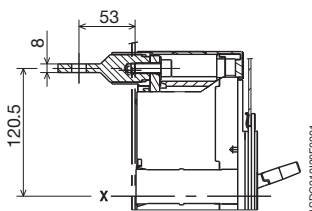

1SDC21030F0001

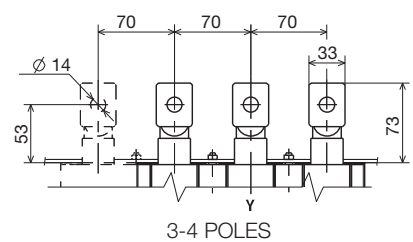

1SDC21031F0001

3-4 POLES

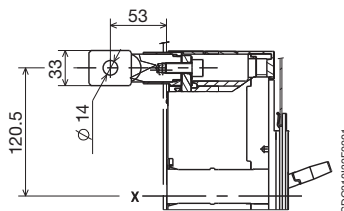

1SDC21032F0001

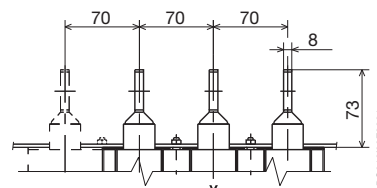

1SDC21033F0001

3-4 POLES

Caption

- ① Low terminal covers with degree of protection IP40

Overall dimensions

Tmax T7

Fixed circuit-breaker Front - F

Caption

- ① Front terminals for flat connection
- ② Busbars
- ③ Flange for the compartment door
- ④ Flange fixing screws
- ⑥ Drilling template for fixing onto support sheet
- ⑦ Tightening torque: 18 Nm
- ⑧ Key lock (optional)
- ⑨ Padlock (optional)
- ⑩ Tightening torque: 2.5 Nm
- ⑪ Sheet drilling for compartment door with flange
- ⑫ Sheet drilling for compartment door for front 206 x 204
- ⑬ Terminal for auxiliary contacts
- ⑭ Reduce flange for the compartment door (optional)
- ⑮ Sheet drilling for compartment door with reduced flange
- ⑯ Sheet drilling for compartment door for front 190 x 105

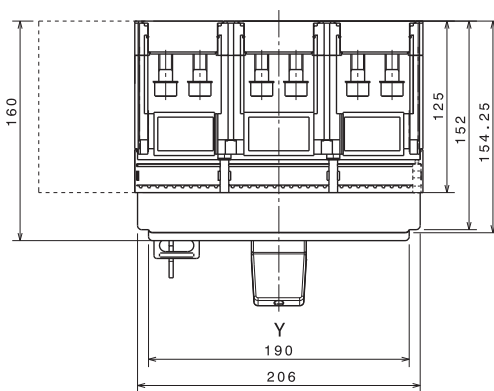
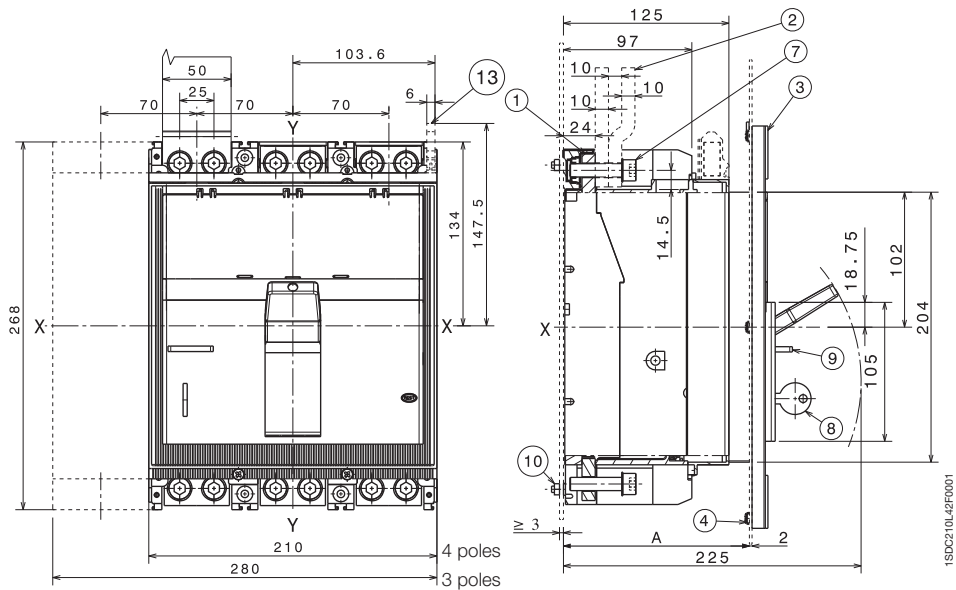

Flange for the compartment door (supplied as standard)

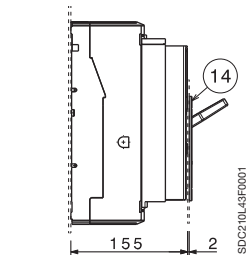
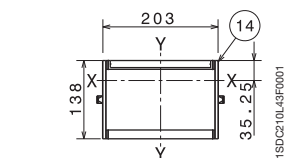
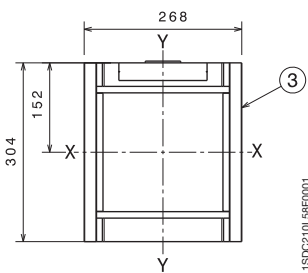

Drilling templates for support sheet

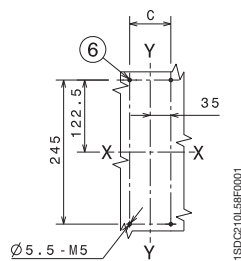

	III	IV
C	70	140

Drilling templates of the compartment door

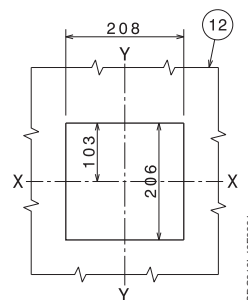
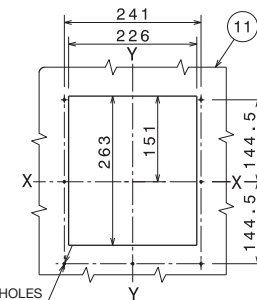
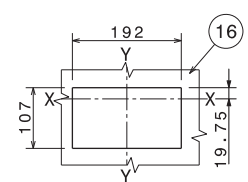
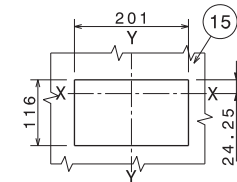

Terminals

Rear flat horizontal or vertical - HR/VR

Caption

- ① Rear horizontal terminals
- ② Rear vertical terminals
- ⑥ Support sheet drilling template
- ⑦ Tightening torque: 20 Nm

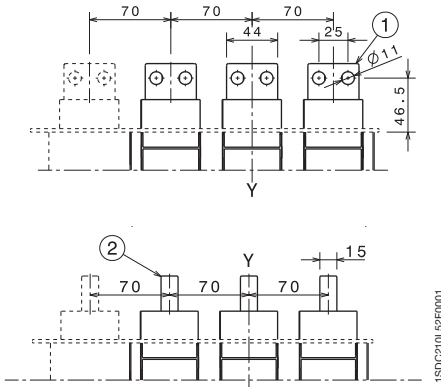
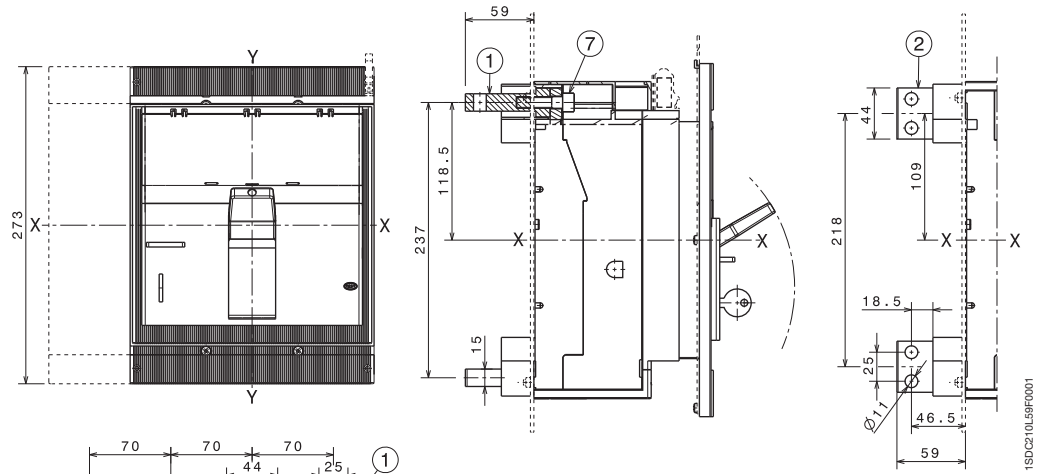

Drilling templates for support sheet

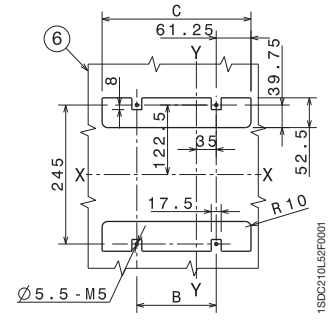

	III	IV
B	70	140
C	192.5	262.5

Overall dimensions

Tmax T7

Terminals

Rear horizontal - R

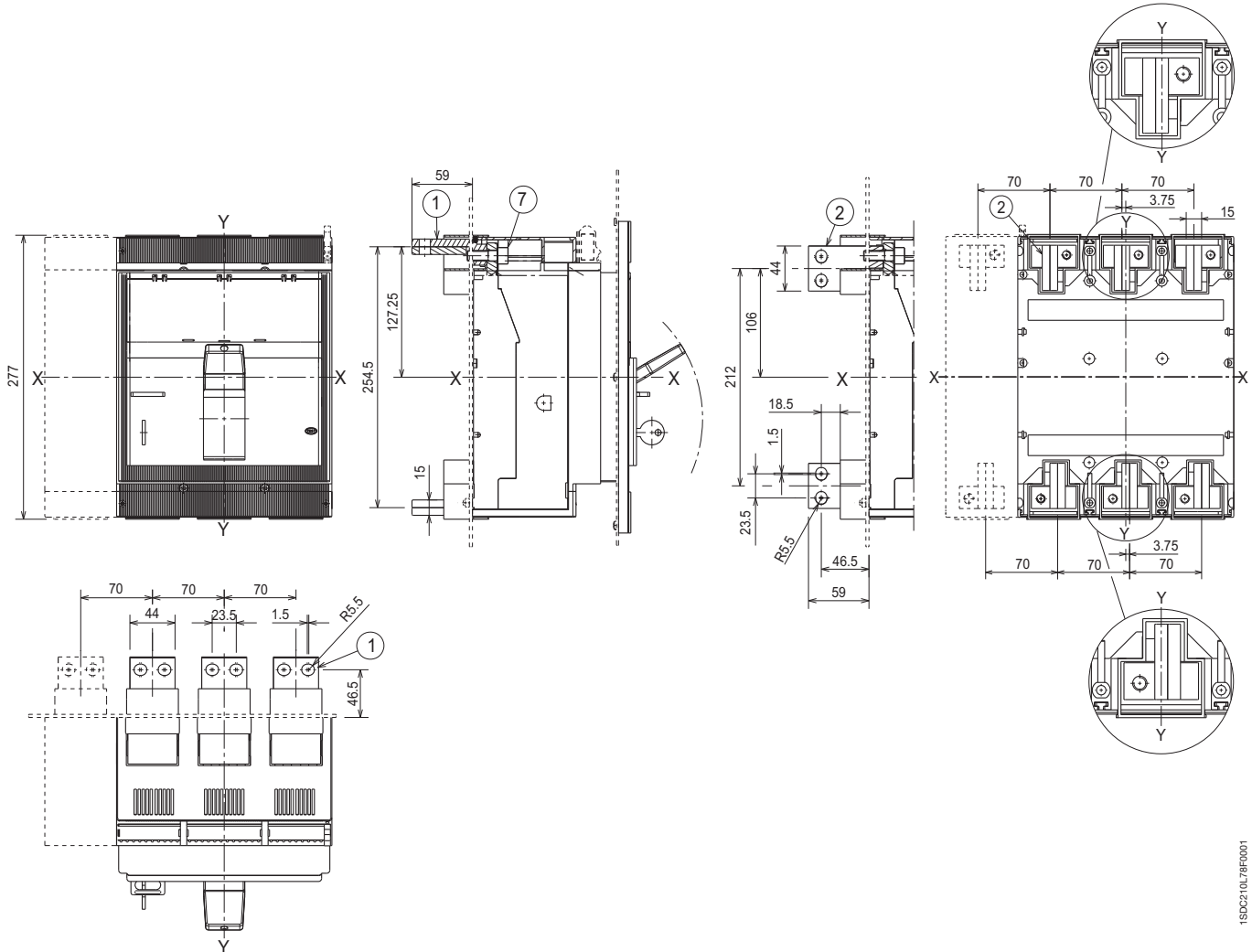

1SDC210L79F0001

Caption

- ① Rear horizontal terminals
- ② Rear vertical terminals
- ⑥ Drilling template for fixing onto support sheet
- ⑦ Tightening torque: 20 Nm

Drilling templates for support sheet

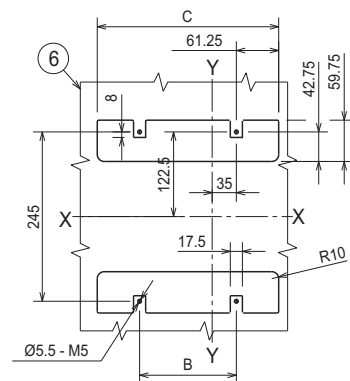

1SDC210L79F0001

	III	IV
B	70	140
C	192.5	262.5

Caption

Front extended - EF

- ① Extended front terminals EF
- ② Extended front spread terminals ES
- ⑥ Drilling template for fixing onto support sheet
- ⑦ Tightening torque: 18 Nm
- ⑧ Phase separator 100 mm
- ⑨ Protection plate
- ⑩ Phase separator 200 mm
- ⑬ Clamp for auxiliary contacts

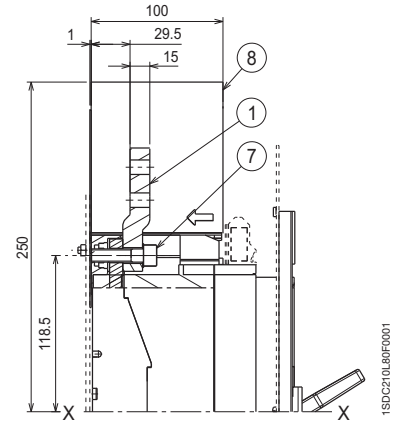
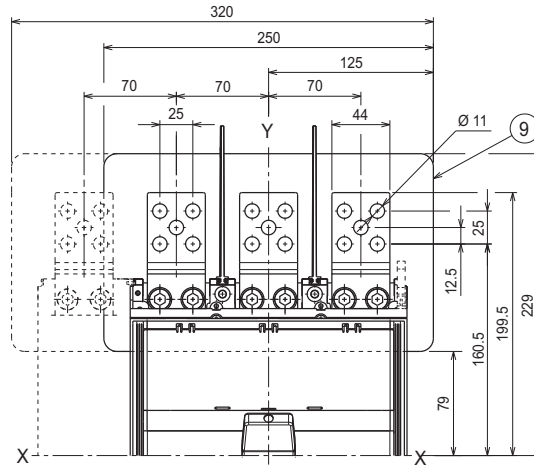

Front extended spread - ES

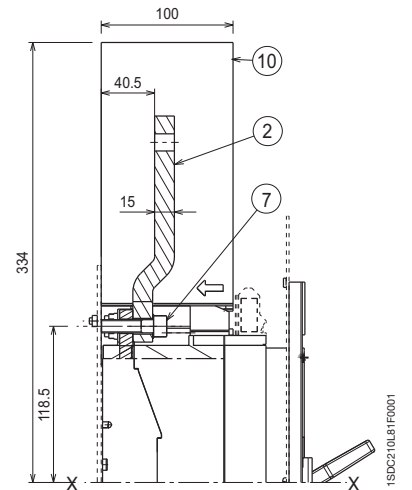
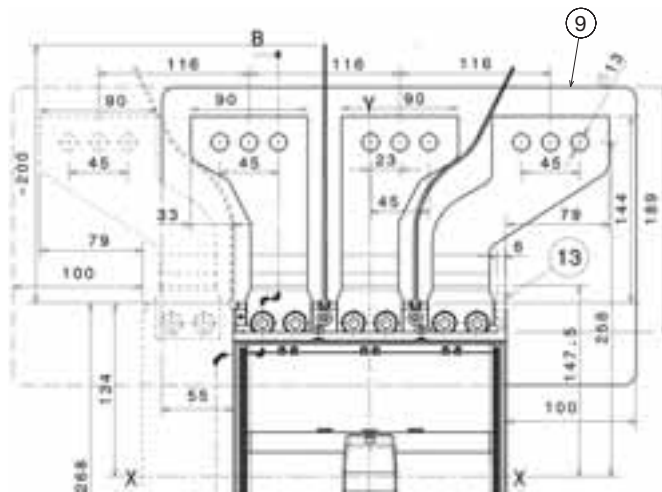

Drilling templates for support sheet

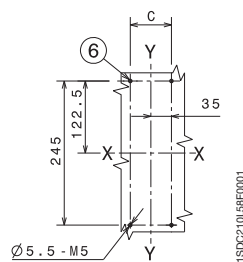

	III	IV
C	70	140

Overall dimensions

Tmax T7

Terminals

Front for copper/aluminium cables - FC CuAl 2x240 mm²

Caption

- ① Front terminals for cables FC CuAl
- ② Tightening torque: 43 Nm
- ⑥ Drilling template for fixing onto support sheet
- ⑦ Tightening torque: 18 Nm
- ⑧ Protection plate

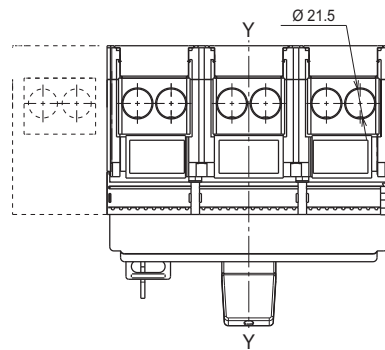
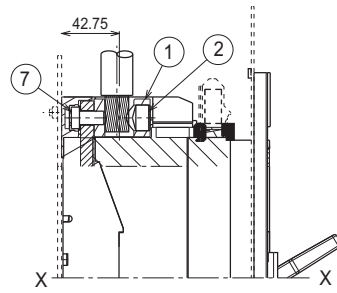
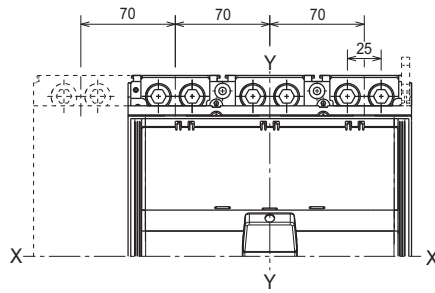

Front for copper/aluminium cables - FC CuAl 4x240 mm²

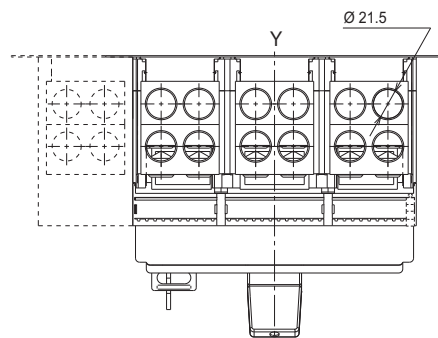
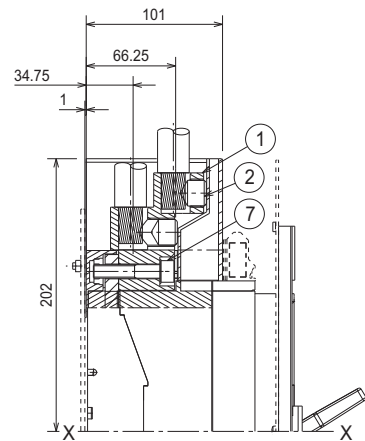
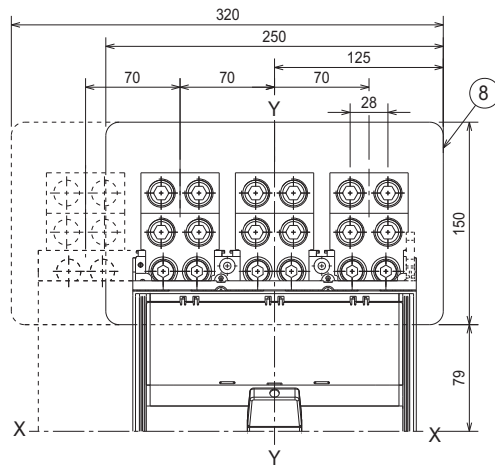

1SDC210L83F0001

1SDC210L83F0001

Overall dimensions

Tmax T7M

Fixed circuit-breaker Front - F

Caption

- ① Front terminal for flat connection
- ② Busbars
- ③ Flange for the compartment door
- ④ Flange fixing screws
- ⑥ Drilling template for fixing onto support sheet
- ⑦ Tightening torque: 18 Nm
- ⑧ Key lock (optional)
- ⑨ Padlock (optional)
- ⑩ Tightening torque: 2.5 Nm
- ⑪ Compartment door with flange sheet drilling
- ⑫ Compartment door without flange sheet drilling
- ⑬ Terminal for auxiliary contacts

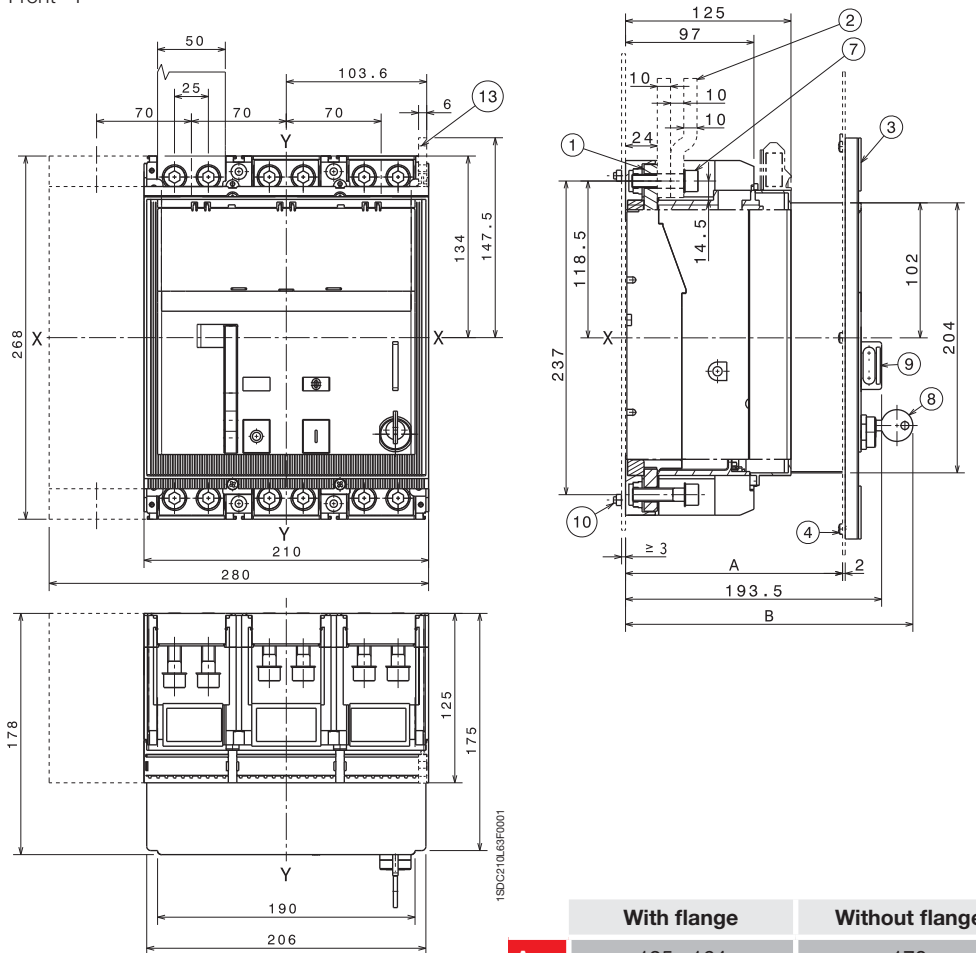

	With flange	Without flange			
A	125...164	170			
B	Standard	Ronis	Profalux	Kirk	Castell
	208	216	224	no	no
C	III	IV			
	70	140			

Flange for the compartment door (supplied as standard)

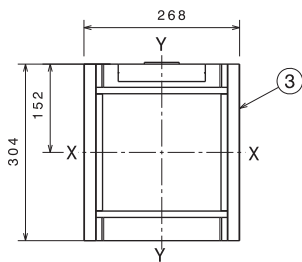

Drilling templates for support sheet

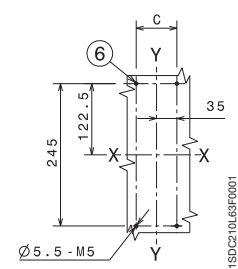

Drilling templates of the compartment door

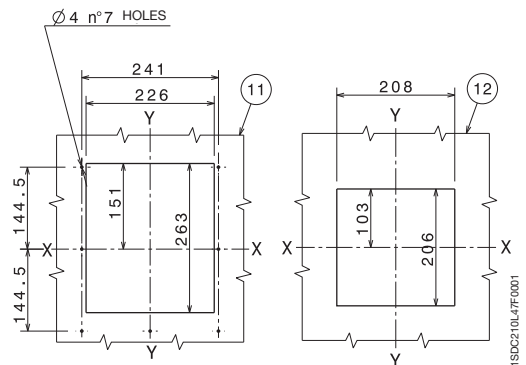

Rear horizontal - R

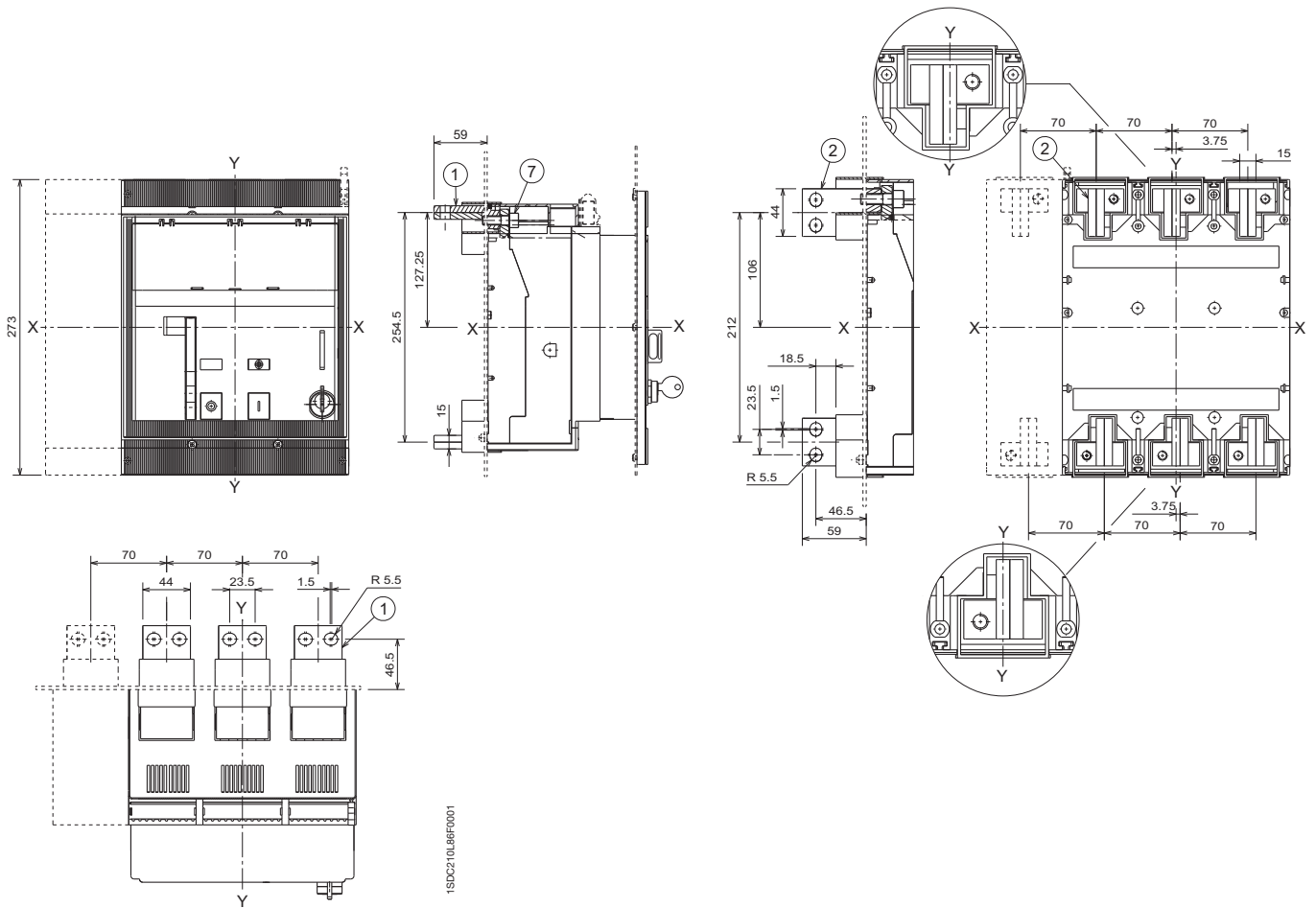

Caption

- ① Rear horizontal terminals
- ② Rear vertical terminals
- ⑥ Drilling template for fixing onto support sheet
- ⑦ Tightening torque 20 Nm

Drilling templates for support sheet

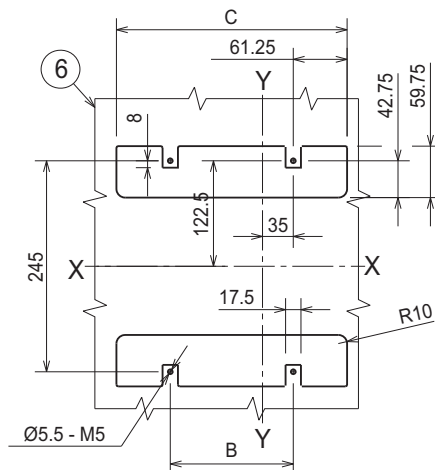

	III	IV
B	70	140
C	192.5	262.5

Overall dimensions

Tmax T7M

Caption

- ① Front extended spread terminals - ES
- ② Tightening torque 18 Nm
- ③ Phase separators 200 mm
- ④ Protection plate
- ⑤ Extended front terminals - EF
- ⑥ Phase separators 100 mm
- ⑬ Overall dimensions of auxiliary contact terminal

Front extended spread - ES

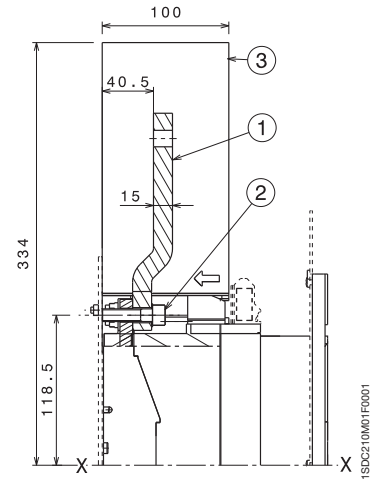
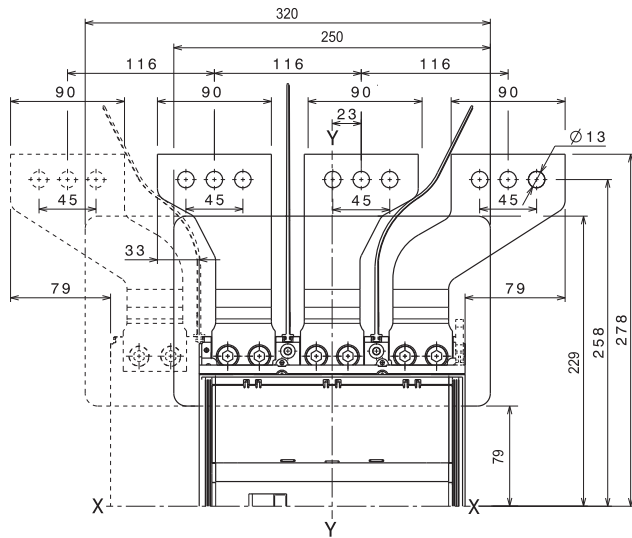

1SDC210M01F0001

Front extended - EF

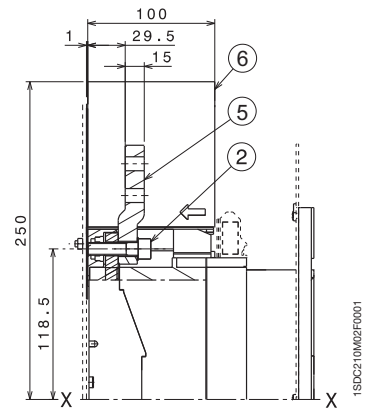
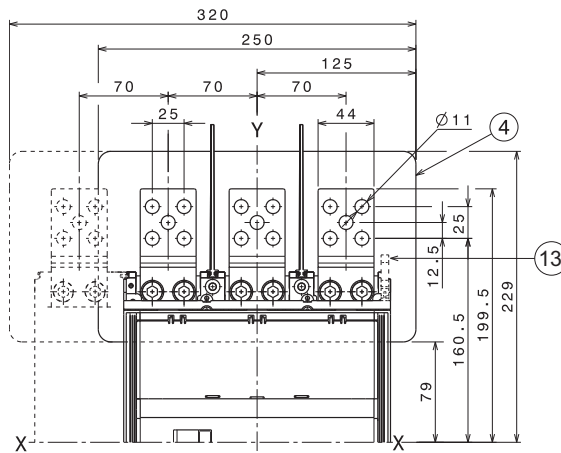

1SDC210M02F0001

Terminals

Front for copper/aluminium cables - FC CuAl 2x240 mm²

Caption

- ① Front terminals for cable FC CuAl
- ② Tightening torque 43 Nm
- ⑦ Tightening torque 18 Nm
- ⑧ Protection plate

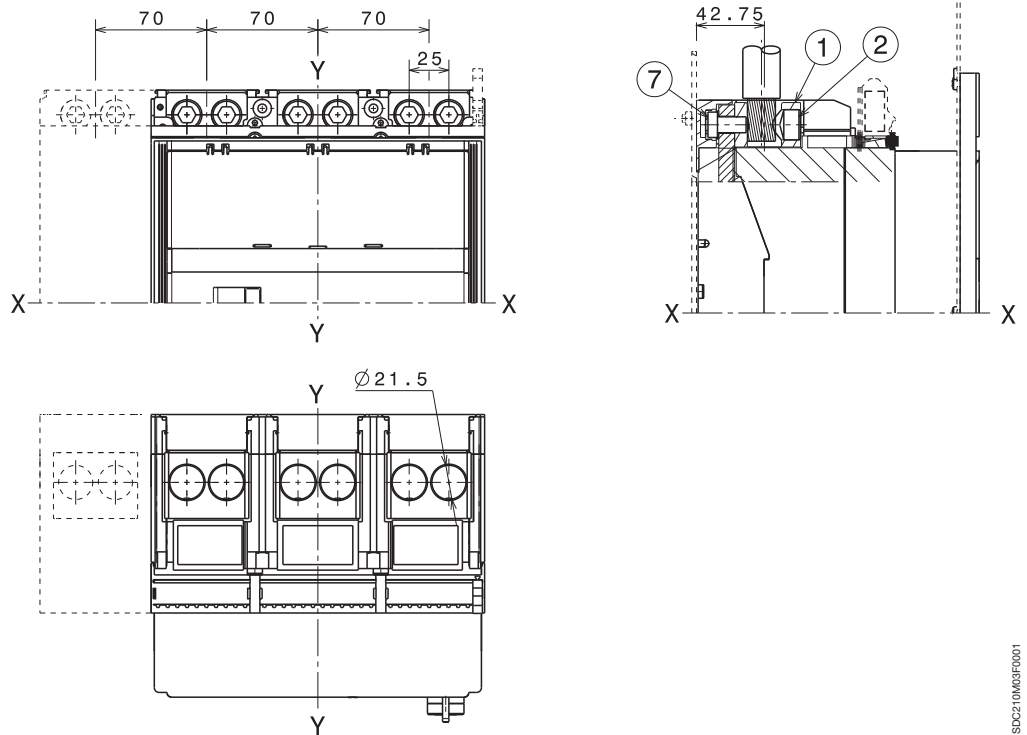

1SDC210M03F0001

Front for copper/aluminium cables - FC CuAl 4x240 mm²

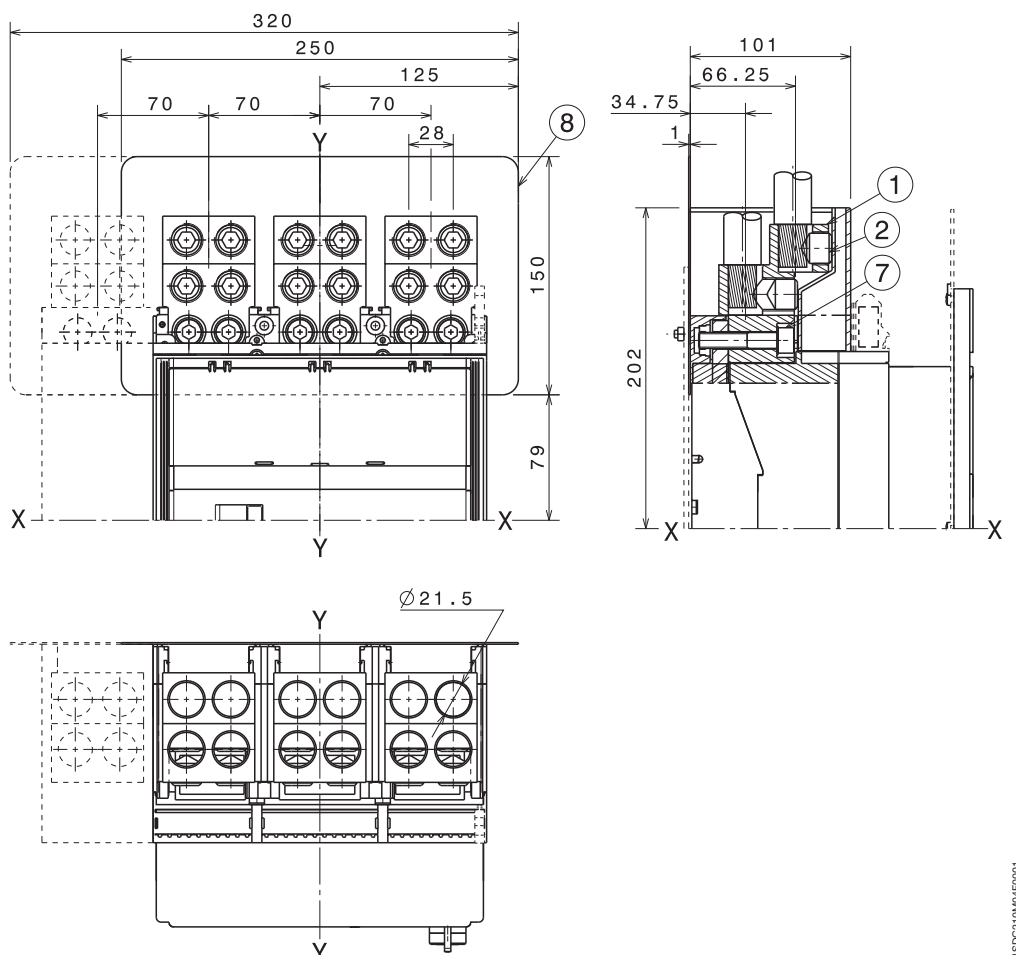

1SDC210M04F0001

Overall dimensions

Tmax T2

Plug-in circuit-breaker

Fixing on sheet

Caption

- ① Depth of the switchboard in the case of circuit-breaker with face not extending from the compartment door, with or without flange
- ② Depth of the switchboard in the case of circuit-breaker with face extending from the compartment door, without flange
- ③ Fixed part
- ④ Moving part with terminal covers, degree of protection IP40

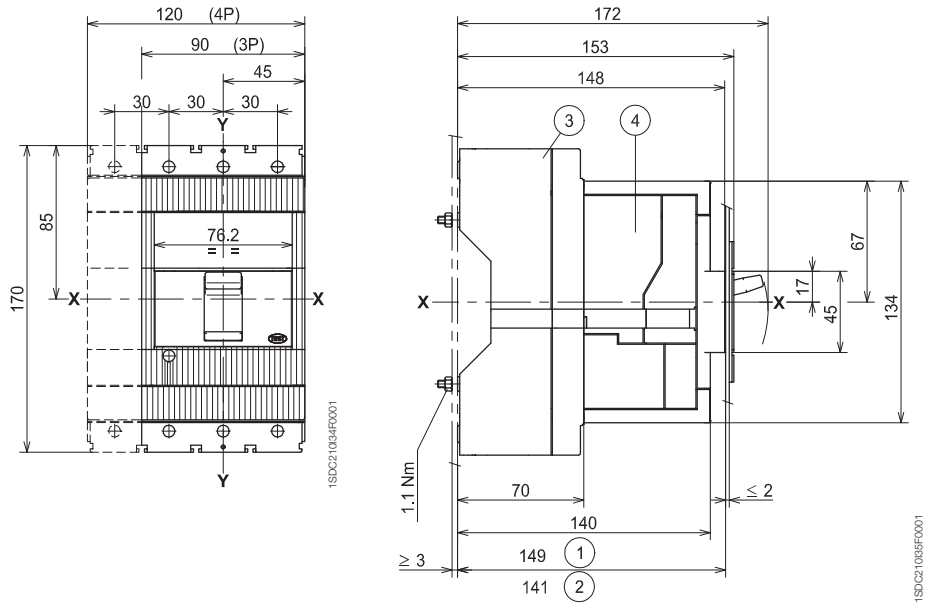

Flange for compartment door

Drilling templates of the compartment door

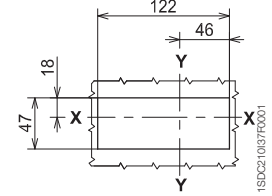
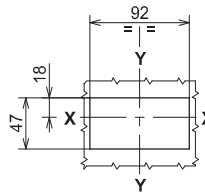
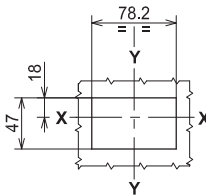
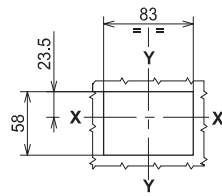
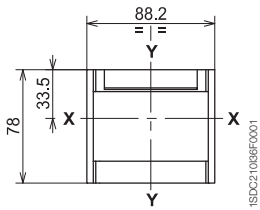

With flange and circuit-breaker face flush with door (3-4 POLES)

Without flange and circuit-breaker face flush with door (3-4 POLES)

Without flange and circuit-breaker face extending (3 POLES)

Without flange and circuit-breaker face extending (4 POLES)

Drilling templates for support sheet

For front terminals

For rear terminals

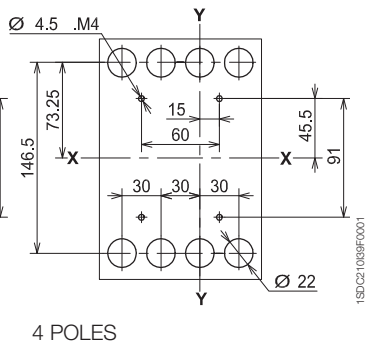
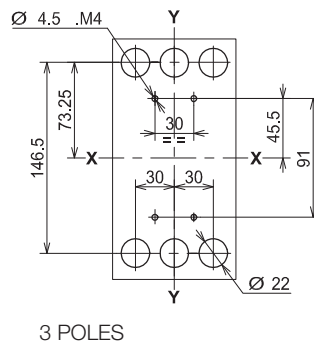
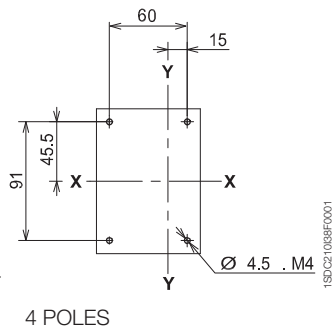
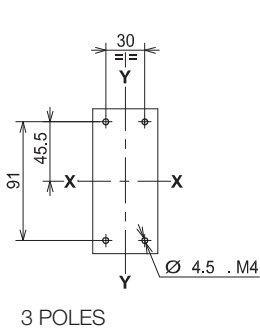

Terminals

Front - F

Front for copper cables - FC Cu

Front for copper/aluminium cables - FC CuAl 95 mm²

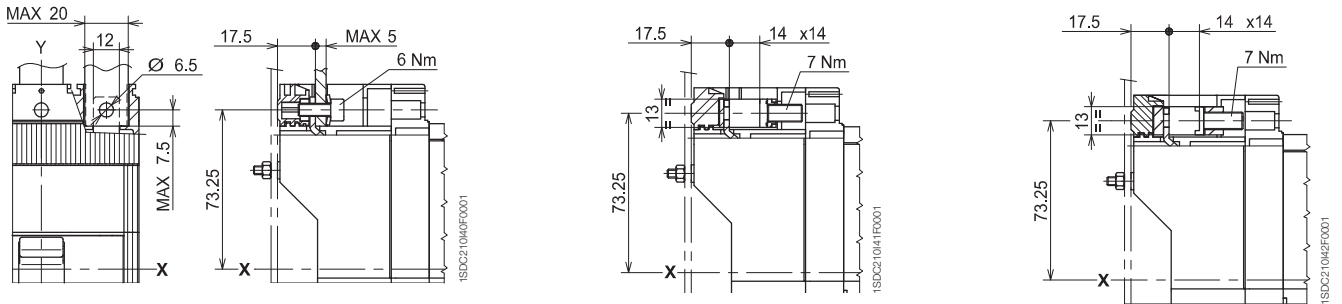

Caption

Front for copper/aluminium cables - FC CuAl 185 mm²

- ① Front extended terminals
- ② Front terminals for cables 185 mm² CuAl
- ③ Insulating courtse plate (compulsory)
- ④ High terminal covers with degree of protection IP40
- ⑤ Drilling templates for support sheet

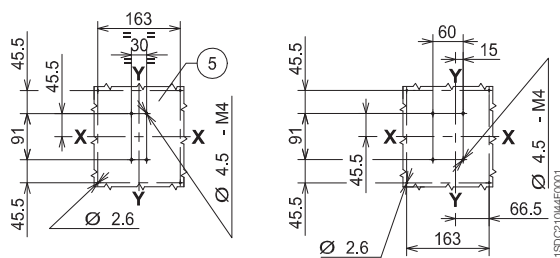
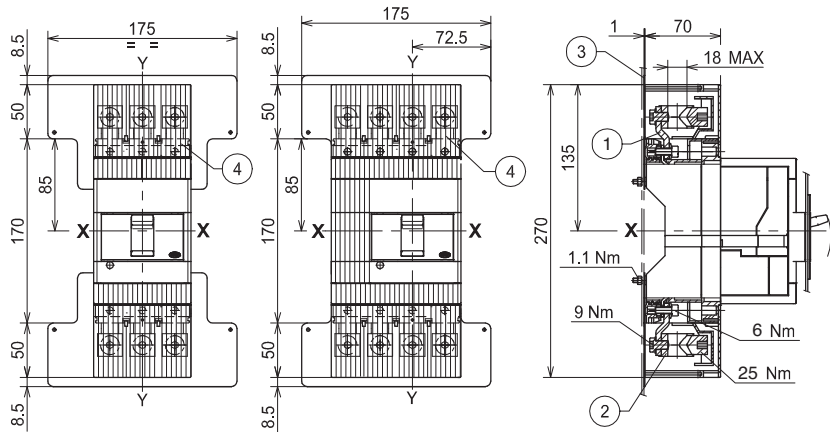

3 POLES

4 POLES

Caption

Front extended spread - ES

- ① Insulating barriers between phases (compulsory)

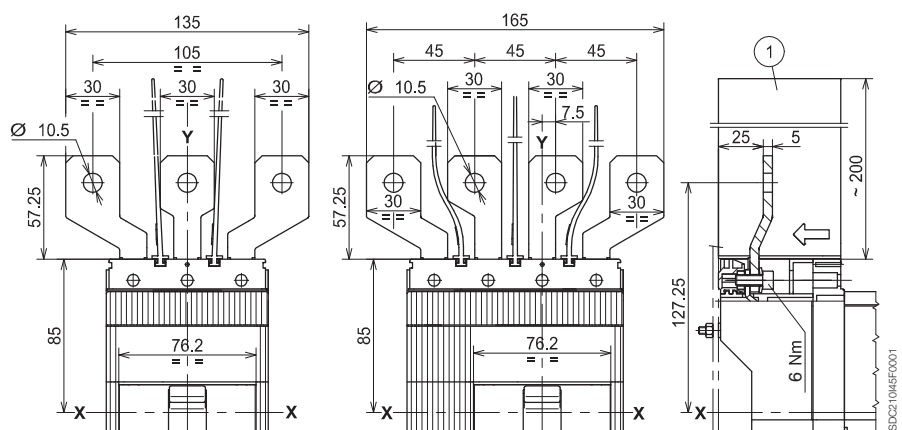

Overall dimensions

Tmax T2

Caption

Front extended - EF

- ① High terminal covers with degree of protection IP40
- ② Insulating barriers between phases (compulsory without 1)

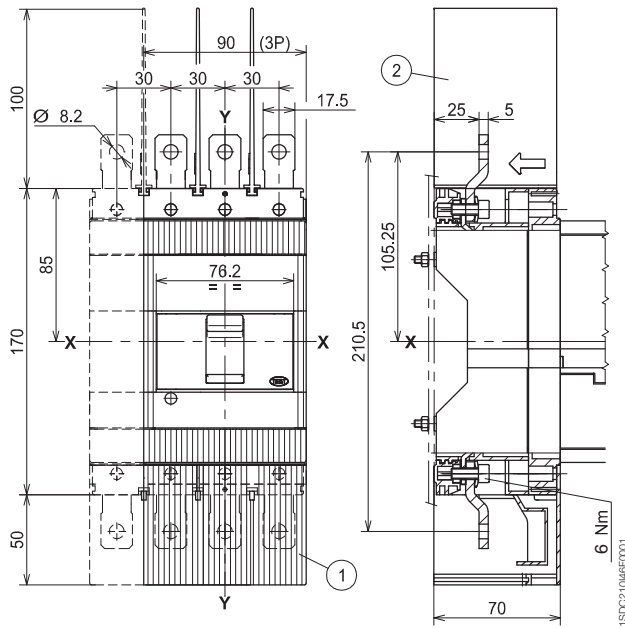

Caption

Rear horizontal - R

- ① Low terminal covers with degree of protection IP40

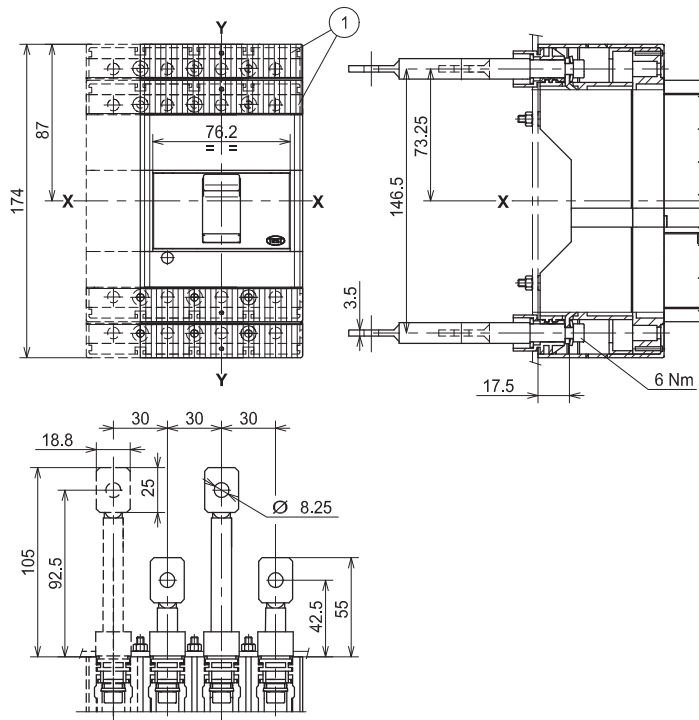

Overall dimensions

Tmax T3

Plug-in circuit-breaker

Fixing on sheet

Caption

- ① Depth of the switchboard in the case of circuit-breaker with face not extending from the compartment door, with or without flange
- ② Depth of the switchboard in the case of circuit-breaker with face extending from the compartment door, without flange
- ③ Fixed part
- ④ Moving part with terminal covers, degree of protection IP40

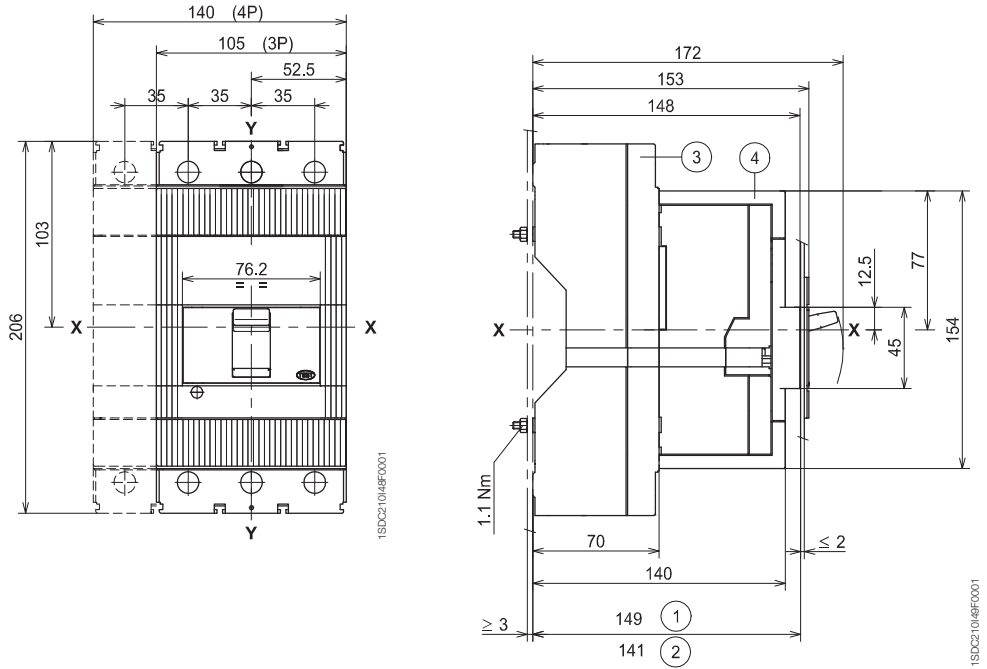

Flange for compartment door

Drilling templates of the compartment door

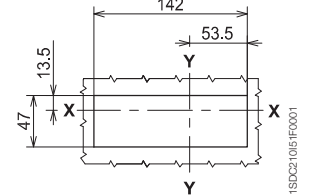
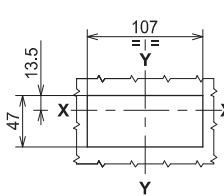
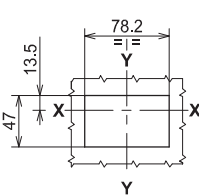
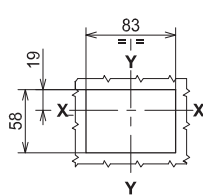
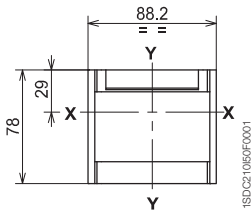

With flange and circuit-breaker face flush with door (3-4 POLES)

Without flange and circuit-breaker face flush with door (3-4 POLES)

Without flange and circuit-breaker face extending (3 POLES)

Without flange and circuit-breaker face extending (4 POLES)

Drilling templates for support sheet

For front terminals

For rear terminals

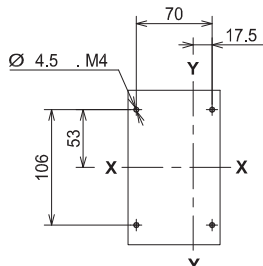
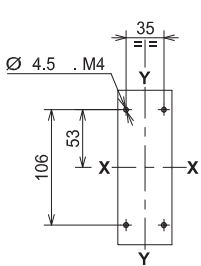

3 POLES

4 POLES

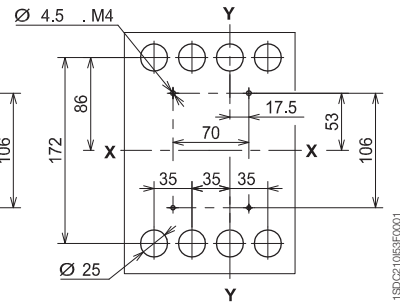
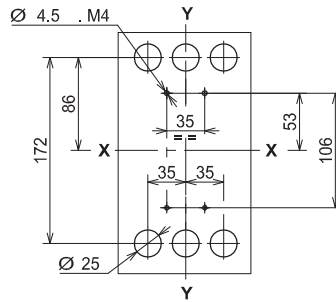

3 POLES

4 POLES

Overall dimensions

Tmax T3

Terminals

Front - F

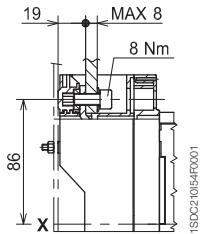
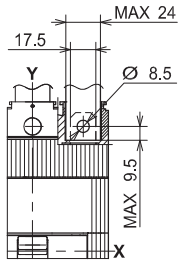

Front for copper cables - FC Cu

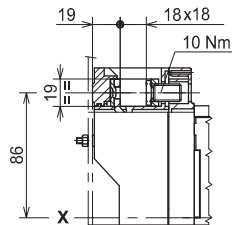

Front for copper/aluminium cables - FC CuAl 185 mm²

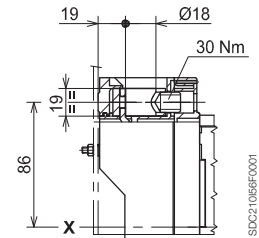

Caption

Front for copper/aluminium cables - FC CuAl 240 mm²

- ① Front extended terminals
- ② Front terminals for cables 240 mm² CuAl
- ③ Insulating courtse plate (compulsory)
- ④ High terminal covers with degree of protection IP40
- ⑤ Drilling templates for support sheet

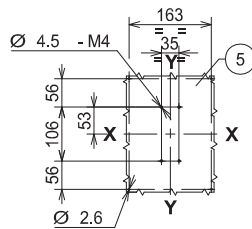
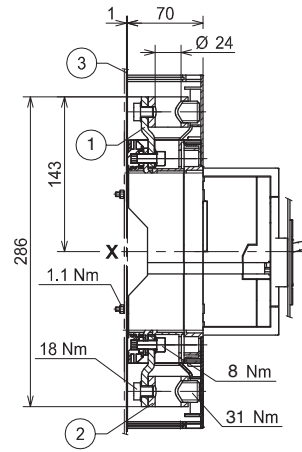
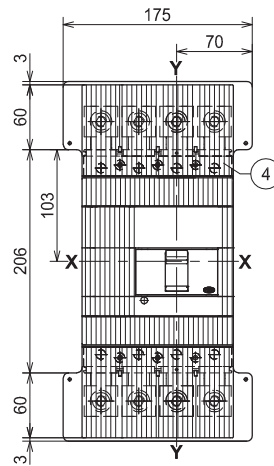
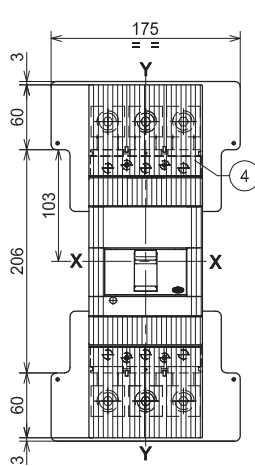

3 POLES

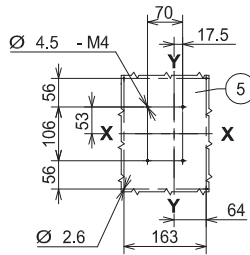

4 POLES

Caption

Front extended spread - ES

- ① Insulating barriers between phases (compulsory)

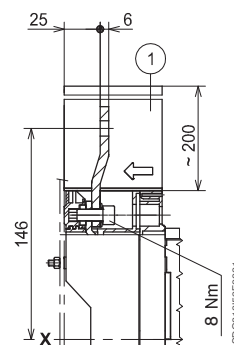
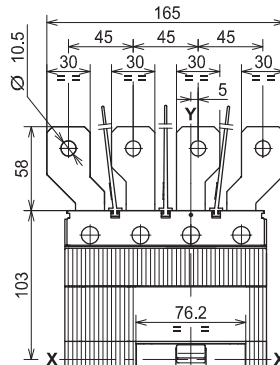
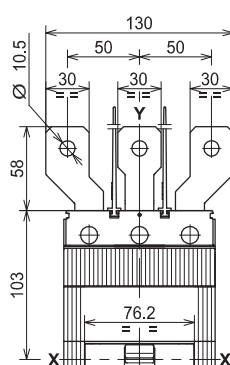

Terminals

Front extended - EF

Caption

- ① High terminal covers with degree of protection IP40
- ② Insulating barriers between phases (compulsory without 1)

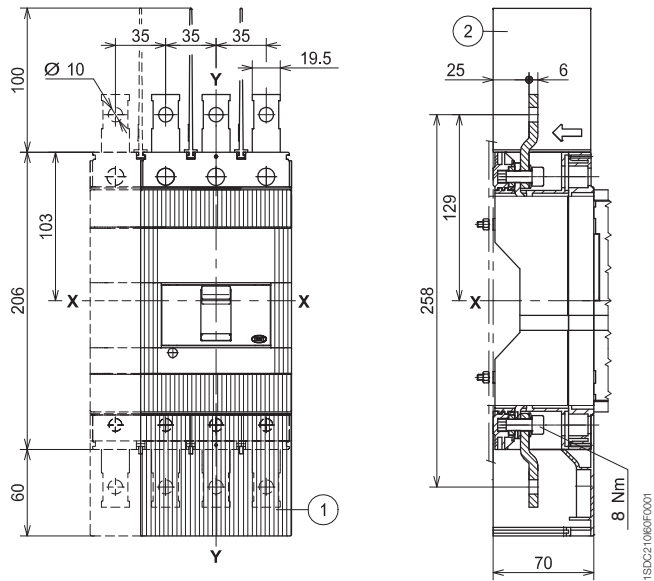

Caption

- ① Low terminal covers with degree of protection IP40

Rear horizontal - R

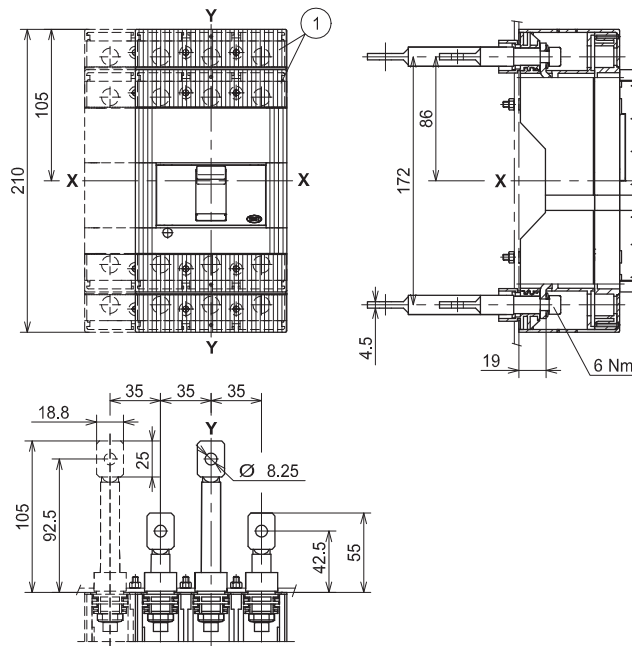

Overall dimensions

Tmax T4

Plug-in circuit-breaker

Fixing on sheet

Caption

- ① Fixed part
- ② Moving part with terminal covers, degree of protection IP40
- ③ Overall dimensions with cabled accessories mounted (SOR-C, UVR-C, RC222-223)
- ④ Overall dimensions with cabled auxiliary contacts mounted (only 3Q 1SY)

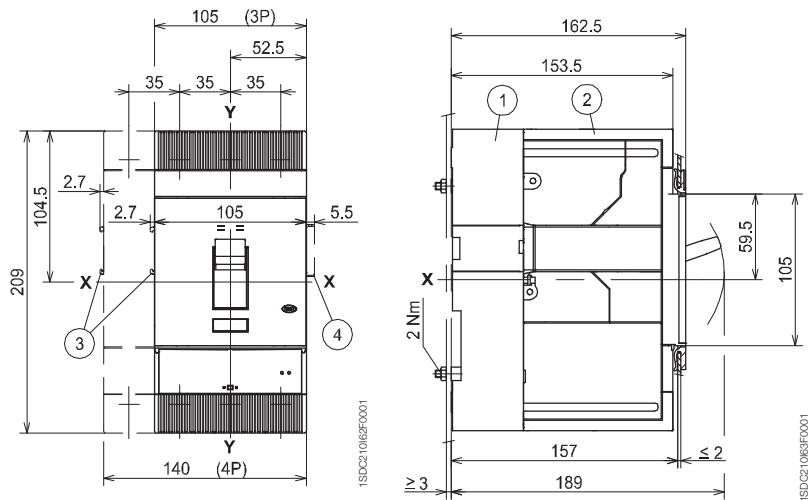

Flange for compartment door

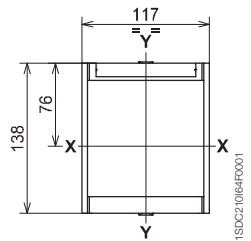

Drilling templates of the compartment door

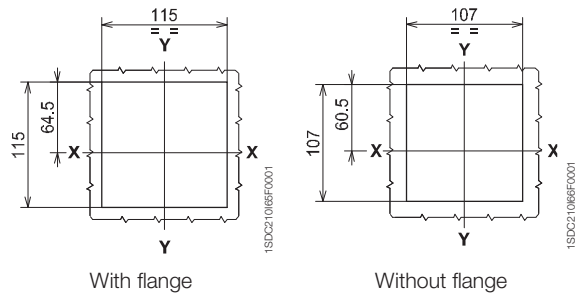

Drilling templates for support sheet

For front terminals

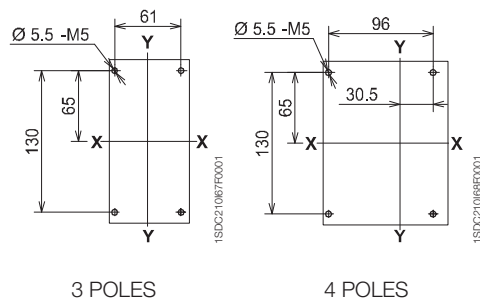

For rear terminals

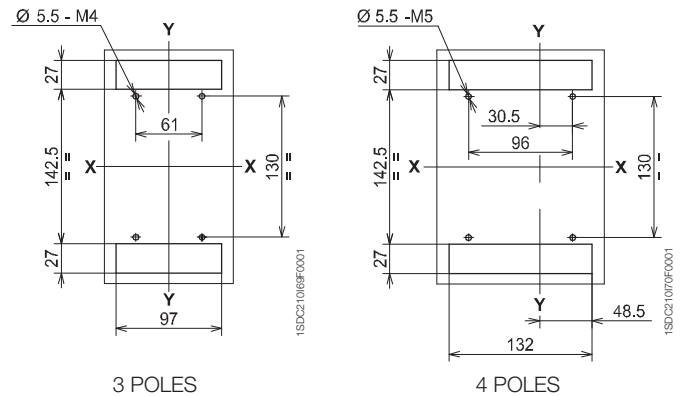

Terminals

Front extended - EF

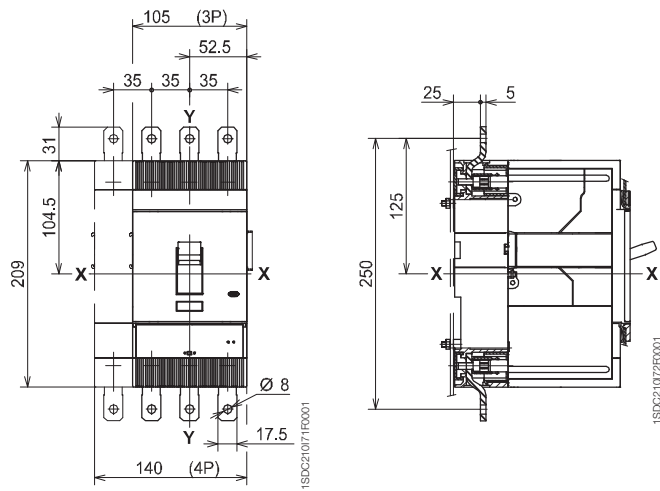

Caption

Front for copper cables - FC Cu or for copper/aluminium cables - FC CuAl

- ① For Cu cables
- ② For Cu Al cables
- ③ High terminal covers with degree of protection IP40

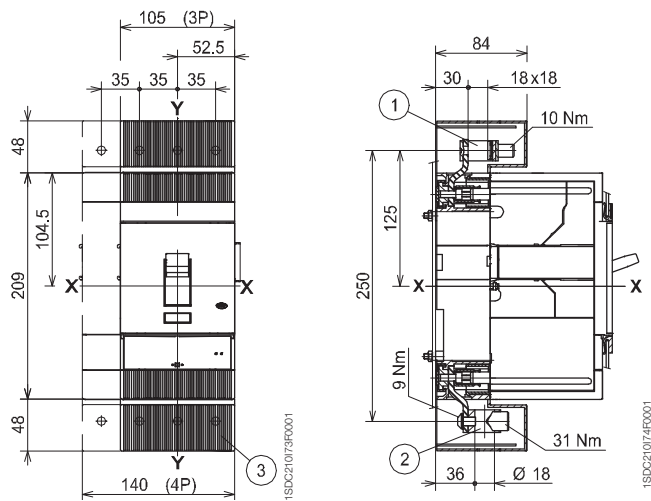

Overall dimensions

Tmax T4

Rear flat vertical - VR

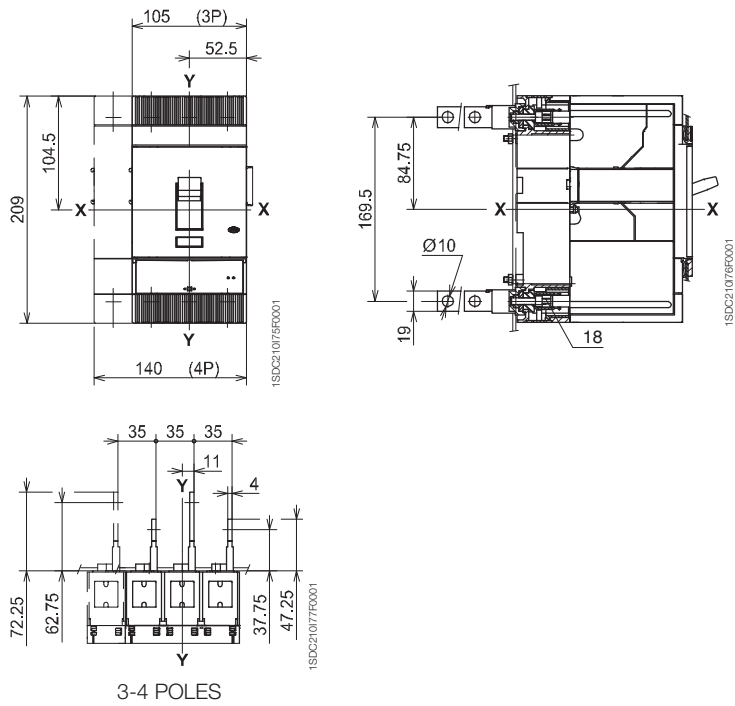

Rear flat horizontal - HR

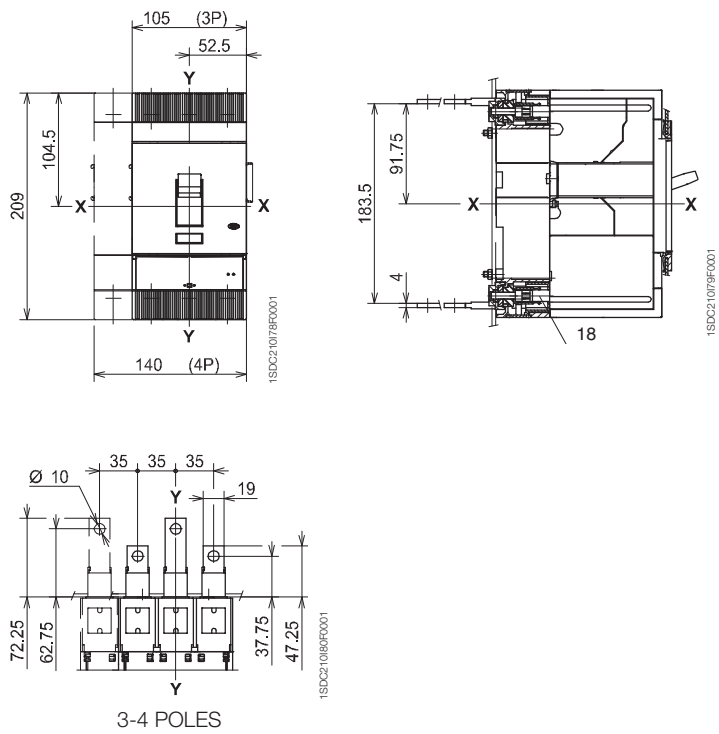

6

Overall dimensions

Tmax T5

Plug-in circuit-breaker

Fixing on sheet

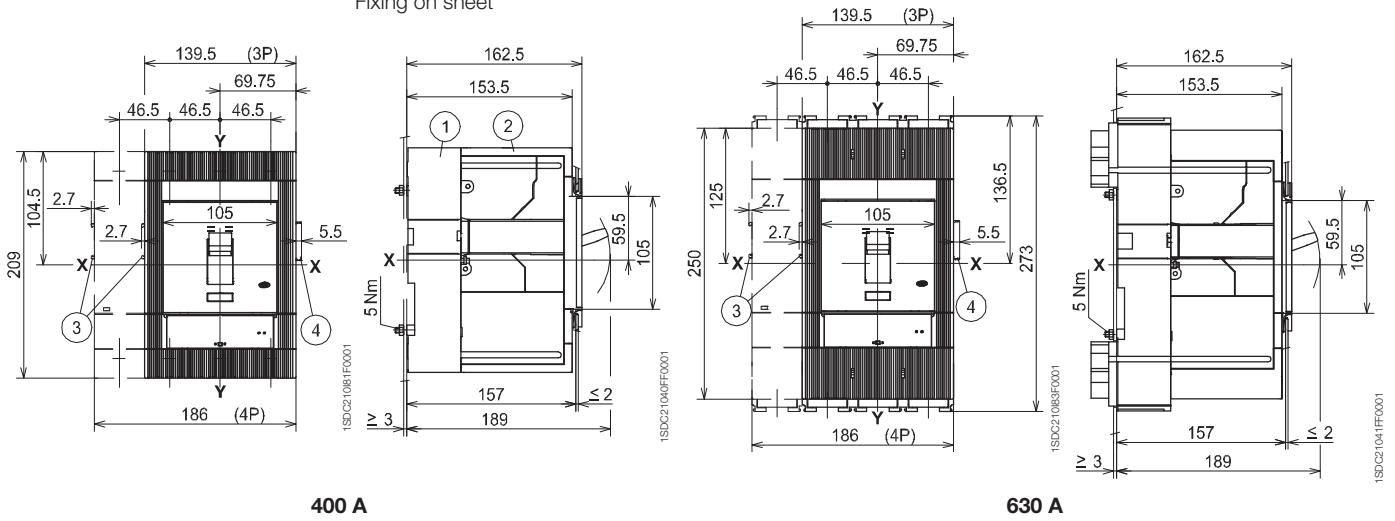

Caption

- ① Fixed part
- ② Moving part with terminal covers, degree of protection IP40
- ③ Overall dimensions with cabled accessories mounted (SOR-C, UVR-C, RC221-222)
- ④ Overall dimensions with cabled auxiliary contacts mounted (only 3Q 1SY)

Flange for compartment door

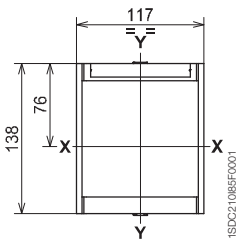

Drilling templates of the compartment door

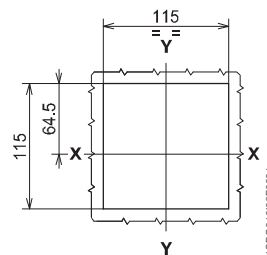

With flange

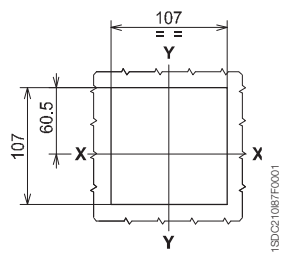

Without flange

Drilling templates for support sheet

For front terminals 400 A

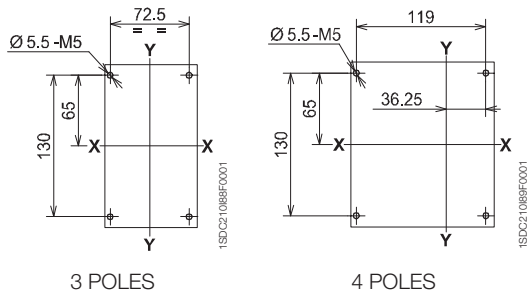

3 POLES

4 POLES

For front terminals 630 A
For rear terminals 400 A - 630 A

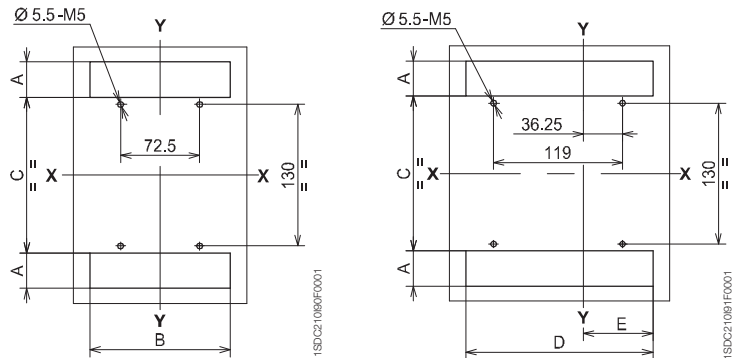

3 POLES

4 POLES

	A	B	C	D	E
Rear 400 A	32.5	128.5	143	172.5	64.5
Front and rear 630 A	61.8	139	142	185.5	69.5

Overall dimensions

Tmax T5

Terminals

Front extended 400 A - EF

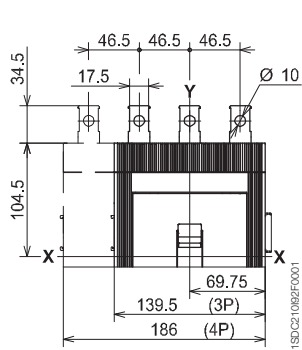

Front extended 630 A - F

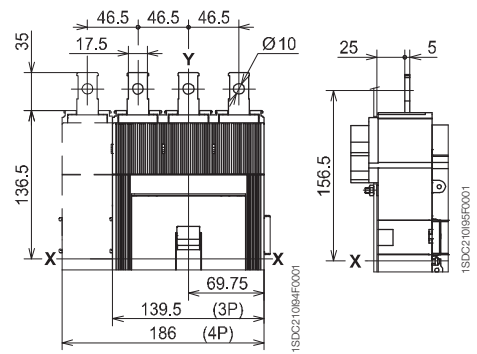

Caption

Front for copper cables - FC Cu or for copper/aluminium cables - FC CuAl

- ① Front terminals for cables Cu
- ② Front terminals for cables Cu/Al
- ③ High terminal covers with degree of protection IP40

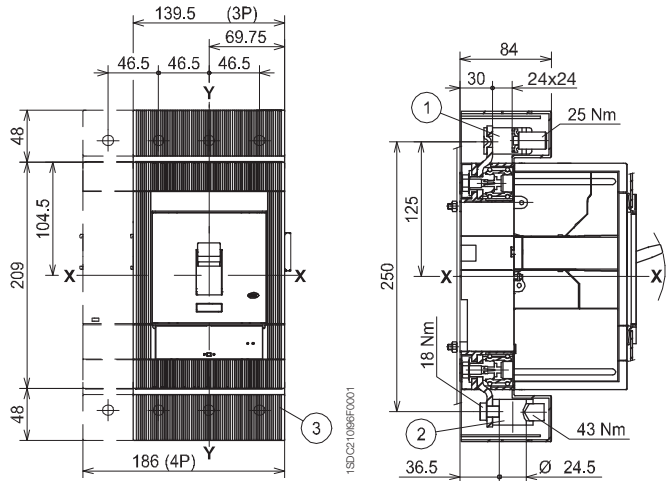

Caption

Front extended spread 630 A - ES

- ① Insulating barriers between phases (compulsory)

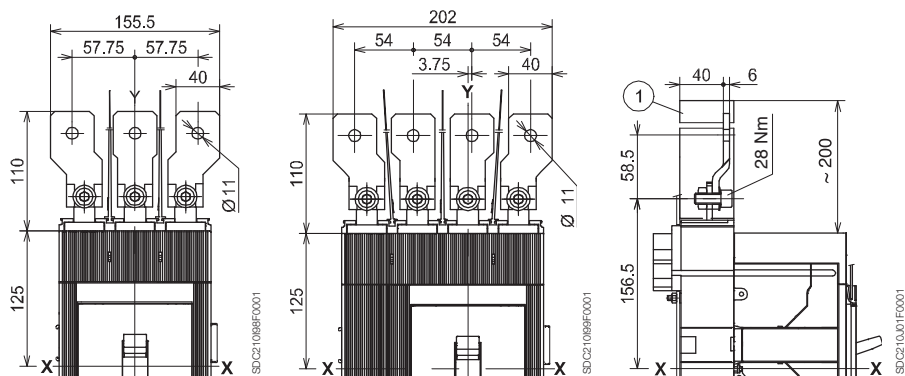

Terminals

Rear flat horizontal 400 A - HR

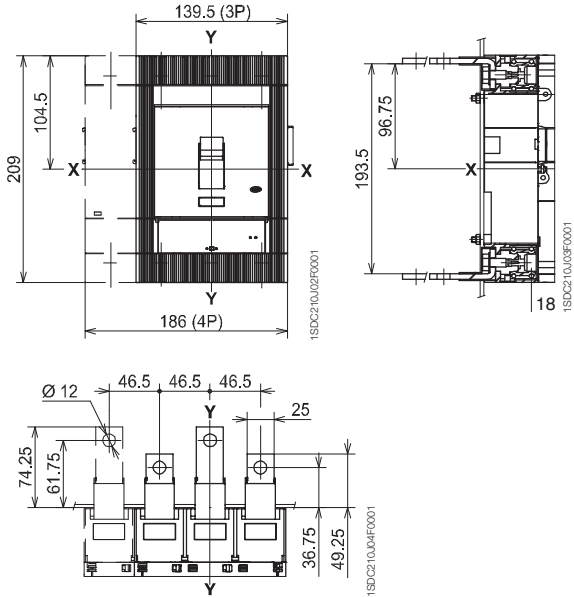

Rear flat vertical 400 A - VR

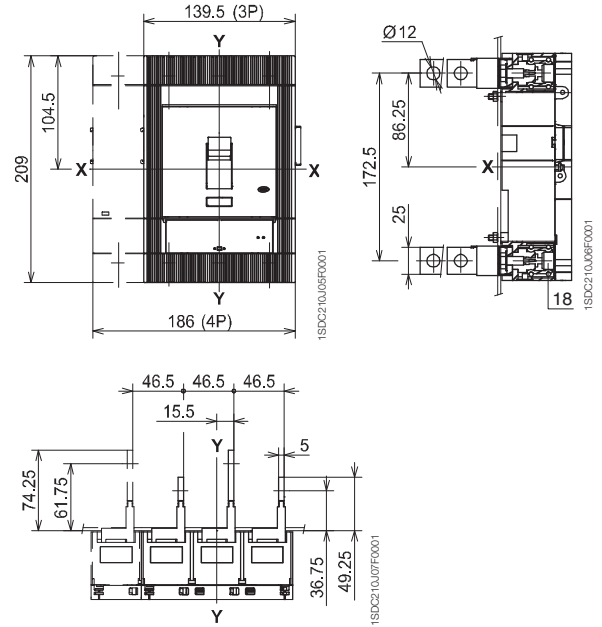

Rear flat horizontal 630 A - HR

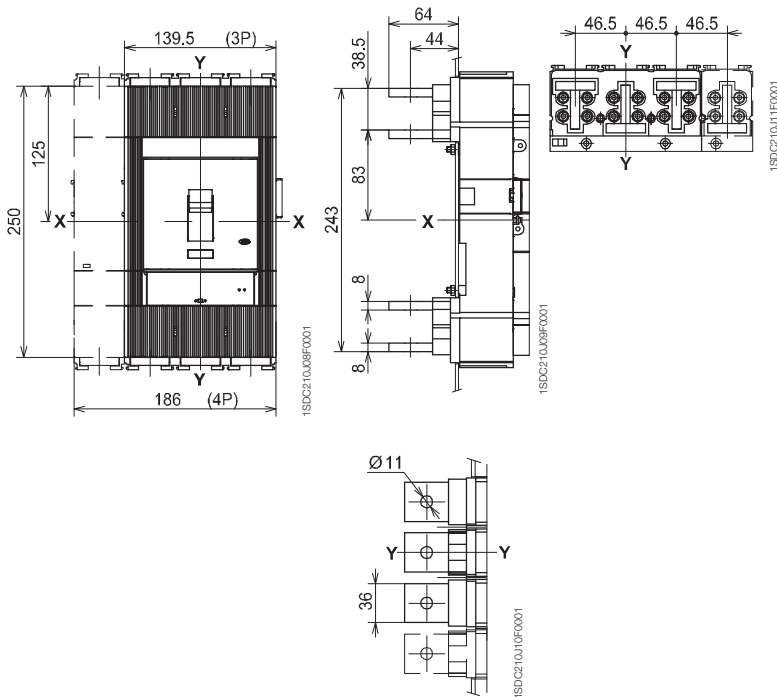

Rear flat vertical 630 A - VR

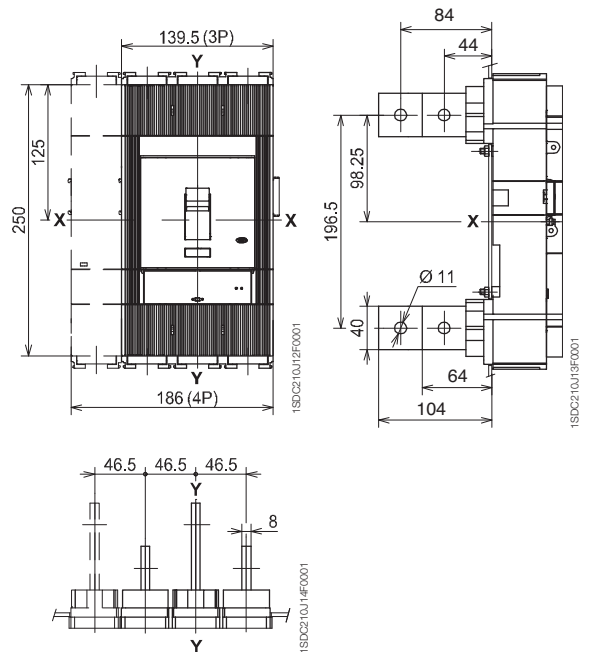

Overall dimensions

Tmax T4

Withdrawable circuit-breaker

Fixing on sheet

Caption

- ① Fixed part
- ② Moving part
- ③ Lock for compartment door (available on request)
- ④ Overall dimensions with cabled accessories mounted (SOR-C, UVR-C, RC222-223)

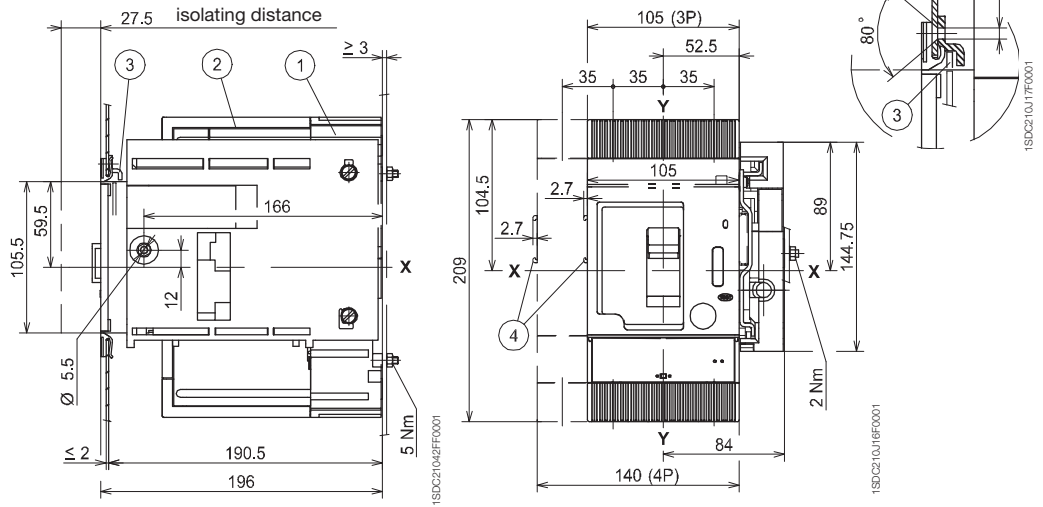

Flange for compartment door

Drilling templates of the compartment door

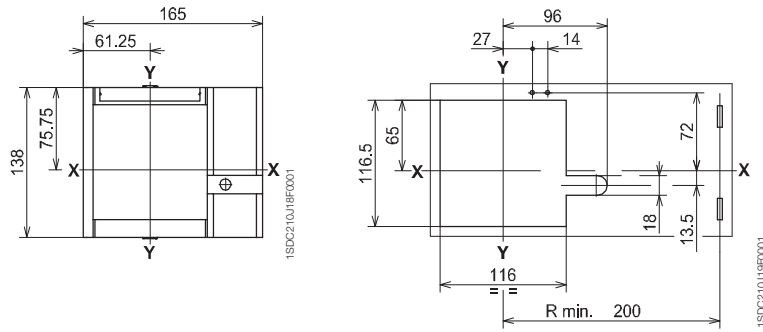

Drilling templates for support sheet

For front terminals

For rear terminals

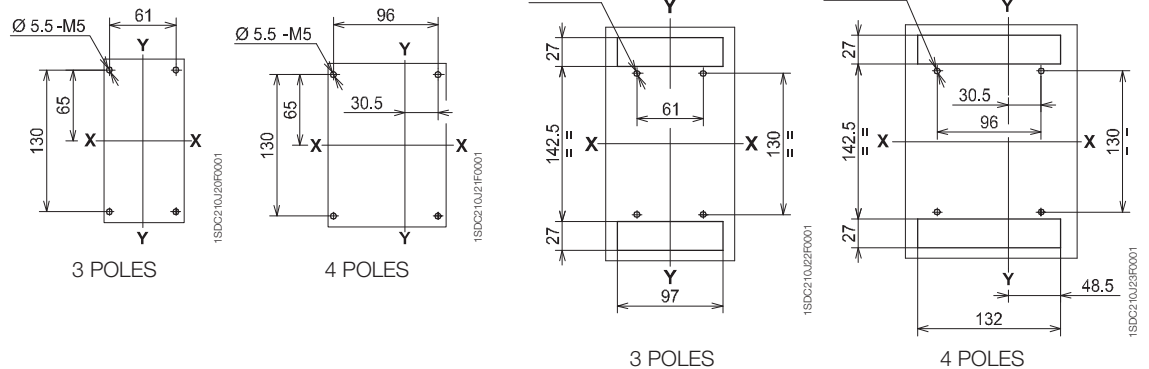

Terminals

Front - EF

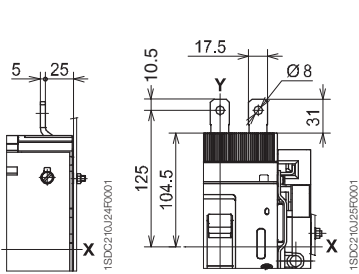

Front for copper cables - FC Cu

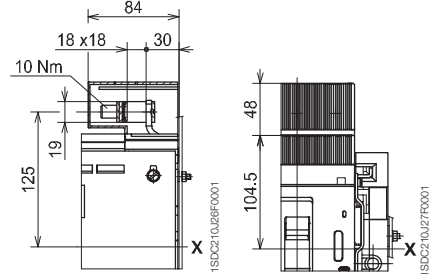

Front for copper/aluminium cables - FC CuAl

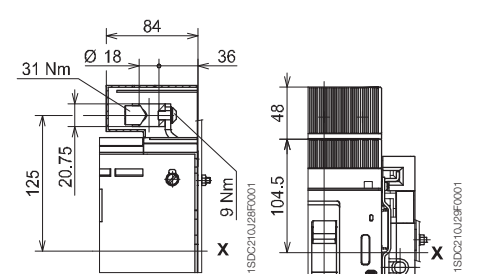

Rear flat horizontal - HR

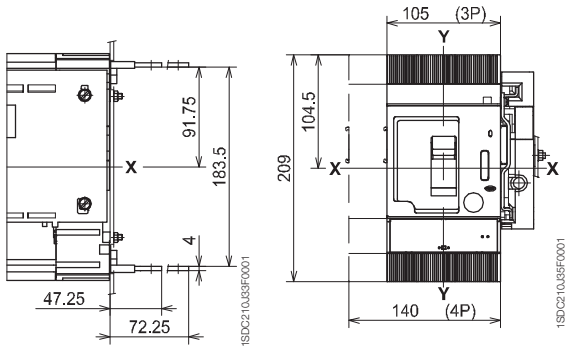

Rear flat vertical - VR

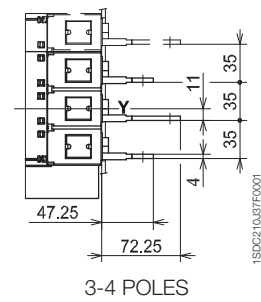
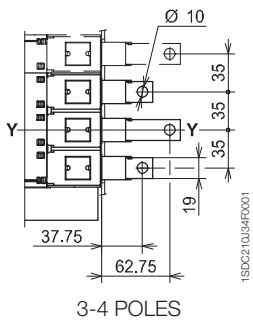
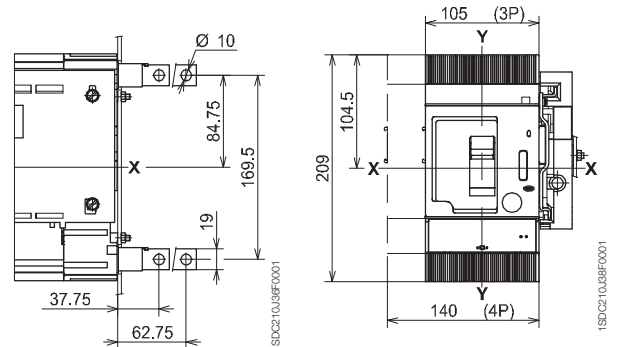

Overall dimensions

Tmax T5

Withdrawable circuit-breaker

Fixing on sheet

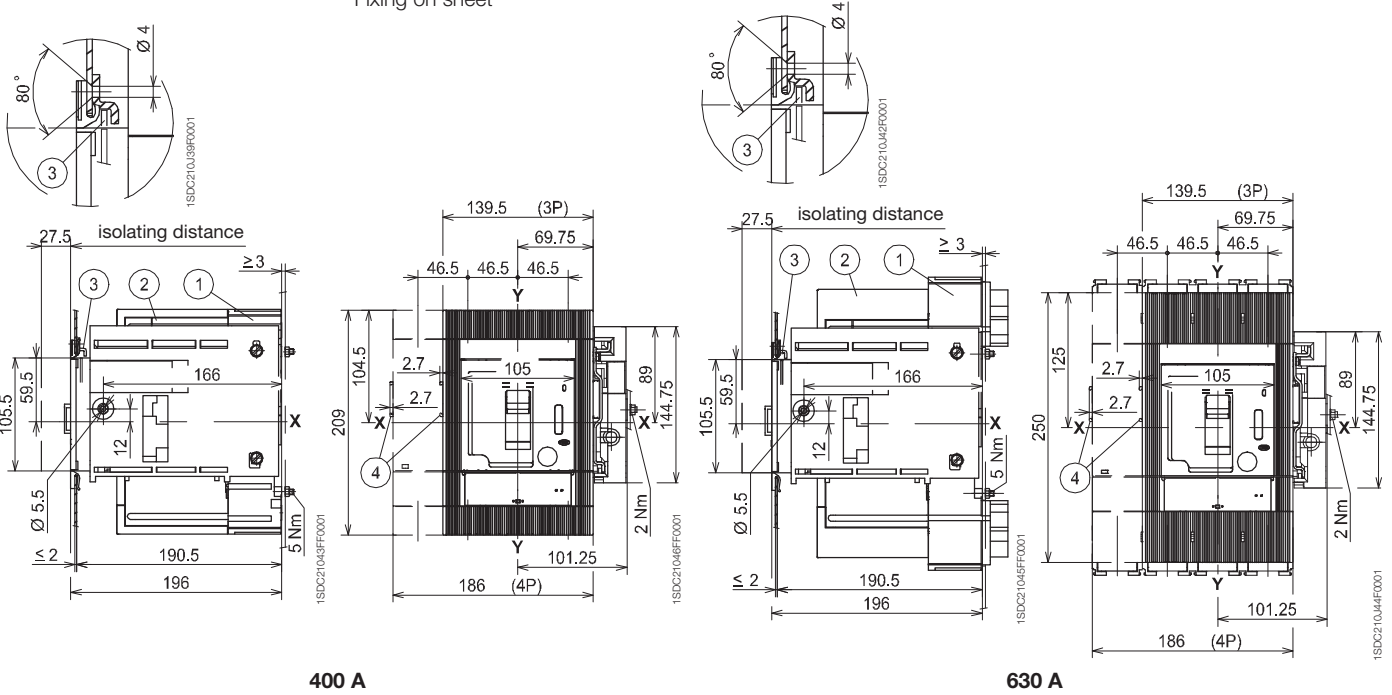

Caption

- ① Fixed part
- ② Moving part with terminal covers, degree of protection IP40
- ③ Lock for compartment door (available on request)
- ④ Overall dimensions with cabled accessories mounted (SOR-C, UVR-C, RC222)

Flange for compartment door

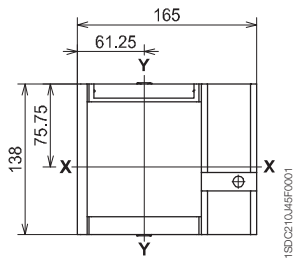

Drilling templates of the compartment door

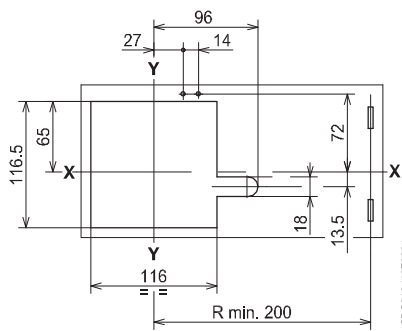

Drilling templates for support sheet

For front terminals 400 A

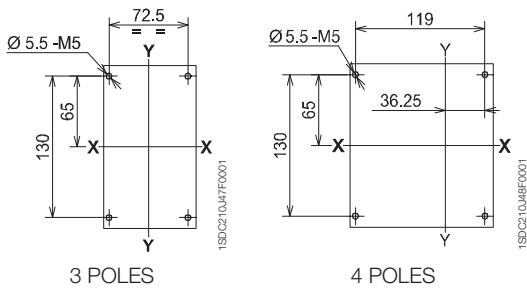

For front terminals 630 A
For rear terminals 400 A - 630 A

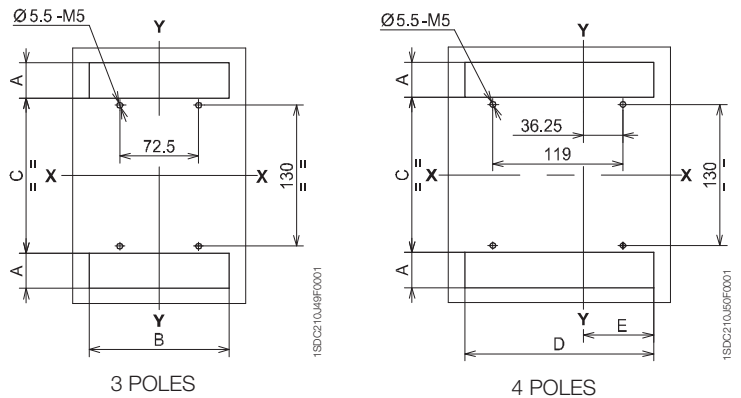

	A	B	C	D	E
Rear 400 A	32.5	128.5	143	172.5	64.5
Front and rear 630 A	61.8	139	142	185.5	69.5

Terminals

Front extended 400 A - EF

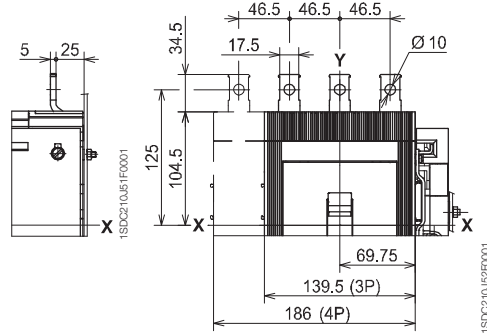

Front extended 630 A - EF

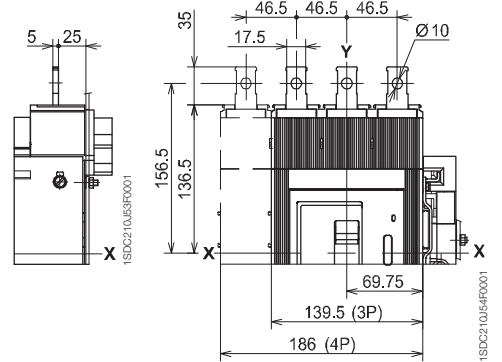

Caption

Front for copper cables - FC Cu or for copper/aluminium cables - FC CuAl 400 A

- ① Front terminals for copper cables
- ② Front terminals for copper/aluminium cables
- ③ Terminals with degree of protection IP40

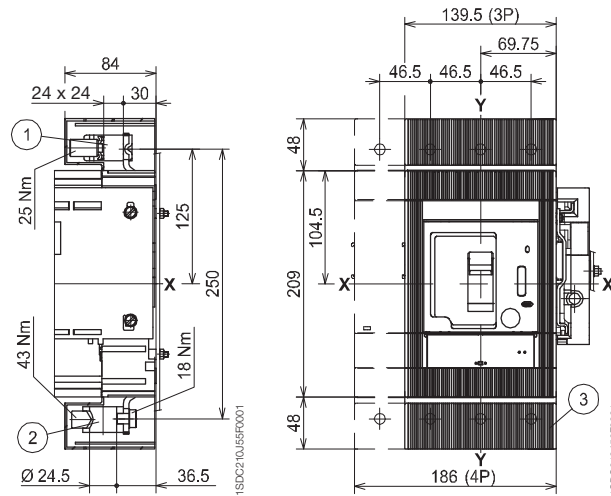

Caption

Front extended spread 400 A - ES

- ① Insulating barriers between phases (compulsory)

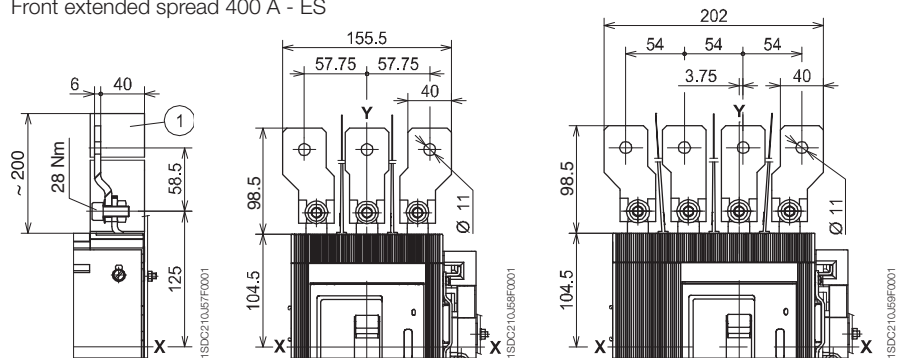

Caption

Front extended spread 630 A - ES

- ① Insulating barriers between phases (compulsory)

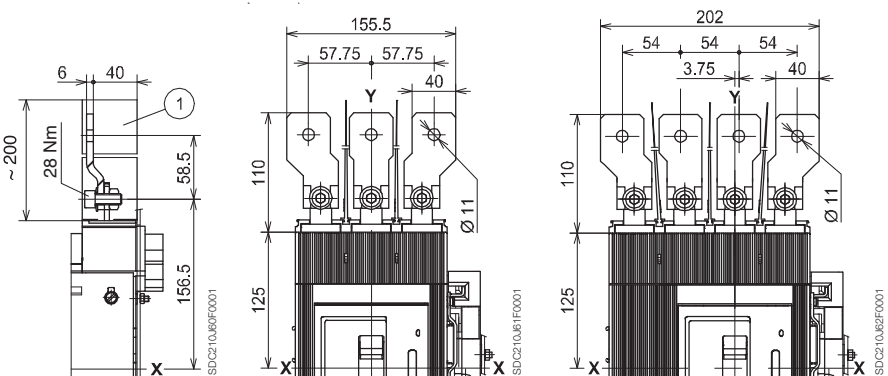

Overall dimensions

Tmax T5

Rear flat horizontal 400 A - HR

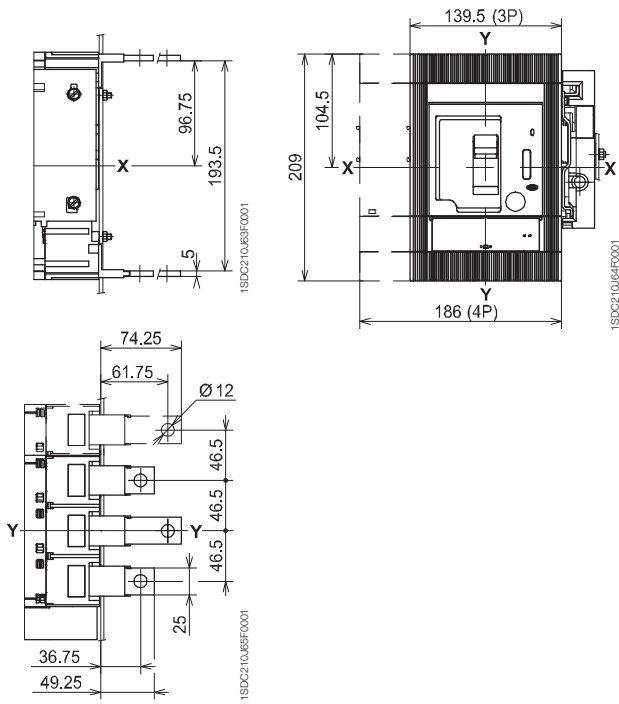

Rear flat vertical 400 A - VR

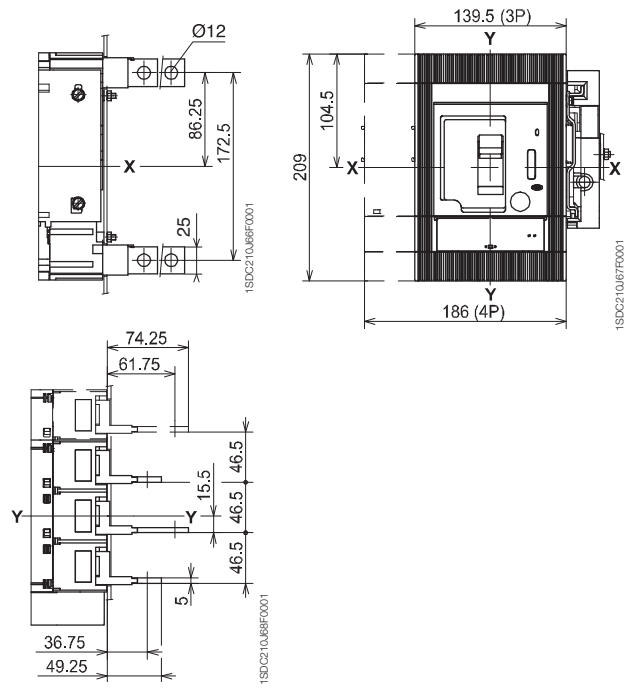

Rear flat horizontal 630 A - HR

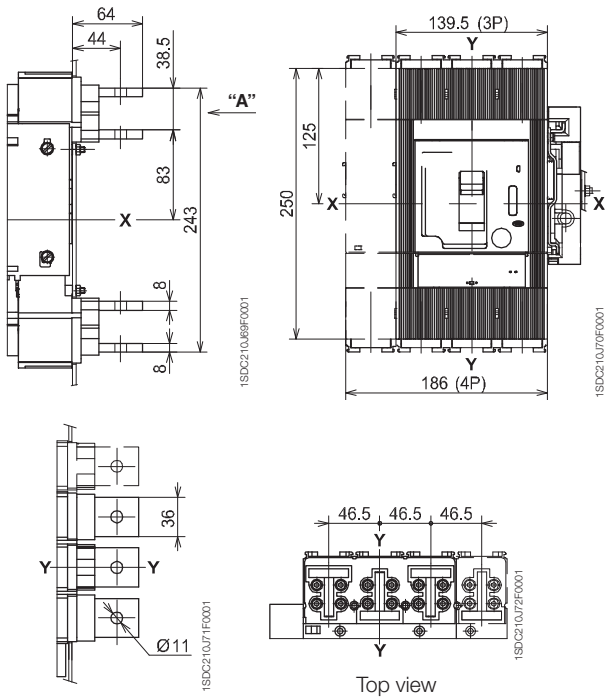

Rear flat vertical 630 A - VR

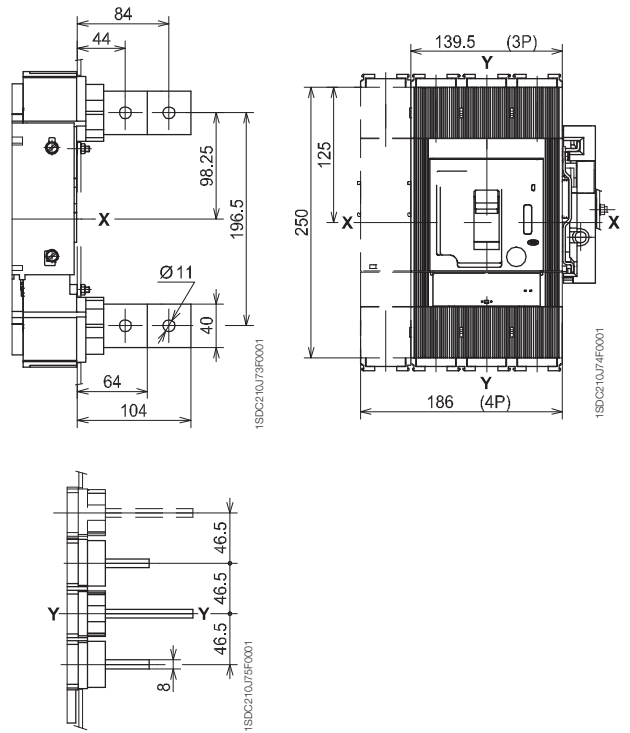

Overall dimensions

Tmax T6 630 A - T6 800 A

Withdrawable circuit-breaker

Caption

- ① Fixed part
- ② Moving part
- ③ Lock for compartment (available on request)
- ④ Overall dimensions with cabled accessories mounted (SOR-C, UVR-C)

Fixing on sheet

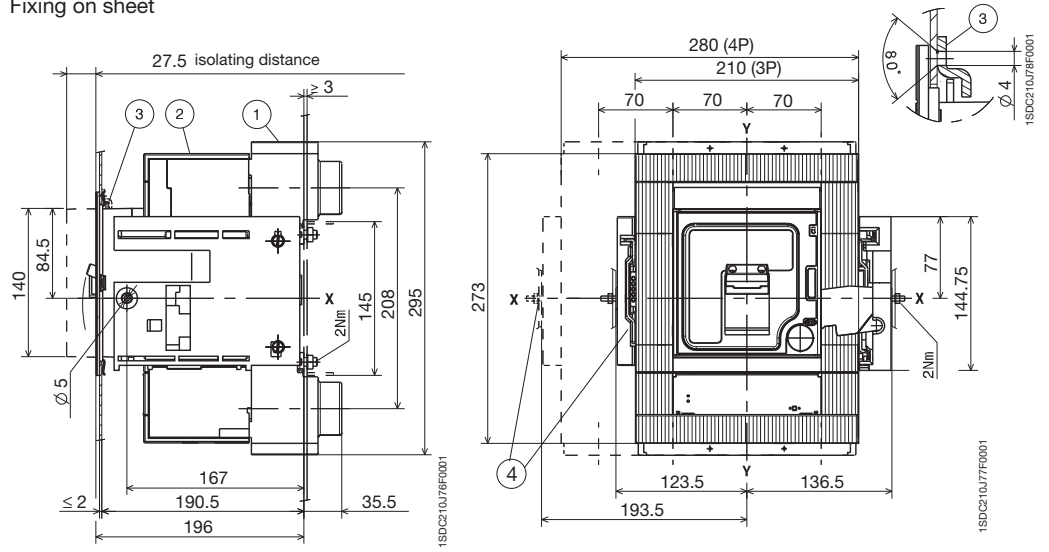

Flange for compartment door

Drilling templates of the compartment door

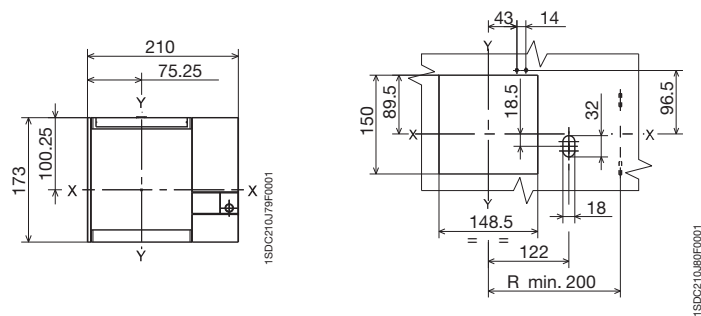

Drilling templates for support sheet

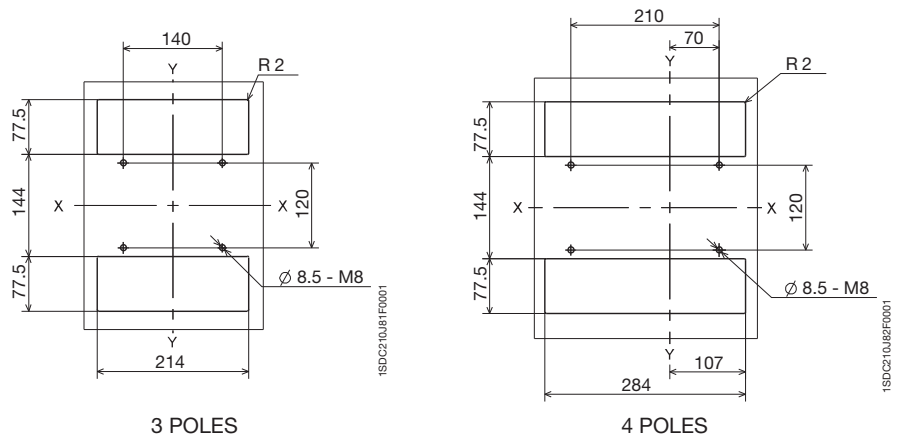

Overall dimensions

Tmax T6 630 A - T6 800 A

Terminals

Front extended - EF

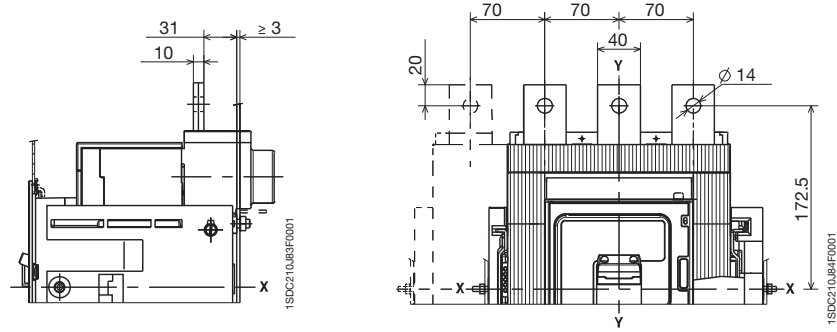

Rear flat horizontal - HR

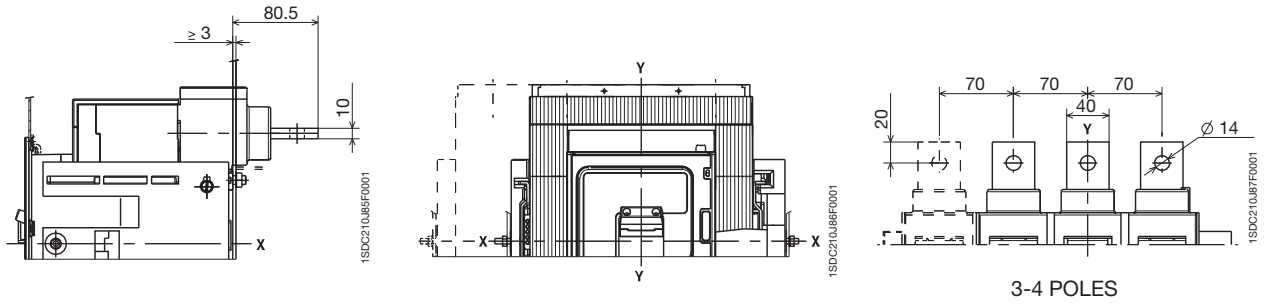

3-4 POLES

Rear flat vertical - VR

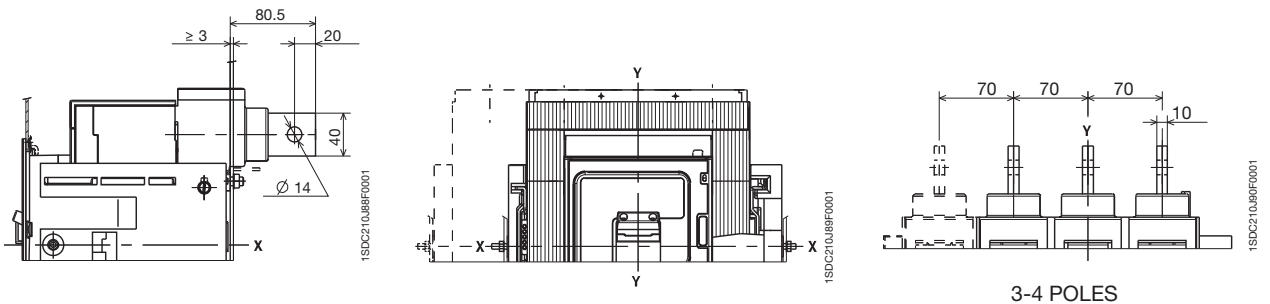

3-4 POLES

Withdrawable circuit-breaker

Fixing on sheet

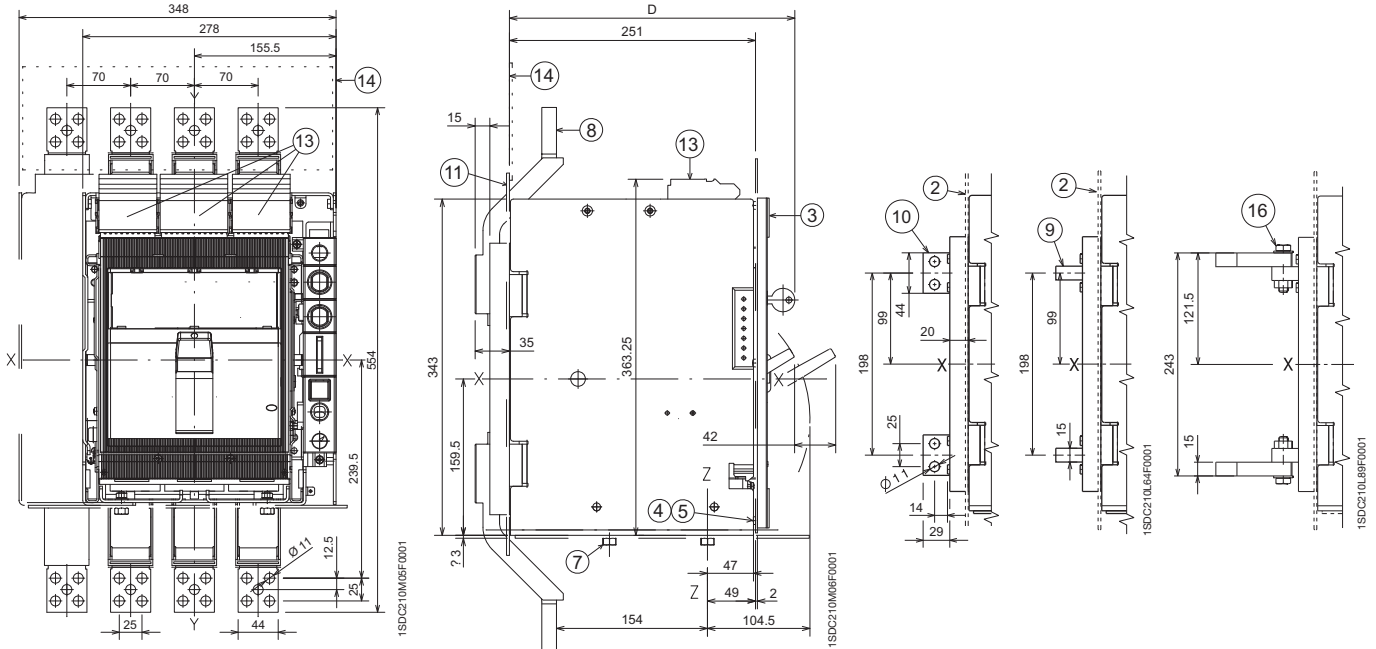

Terminals

Rear flat vertical - VR

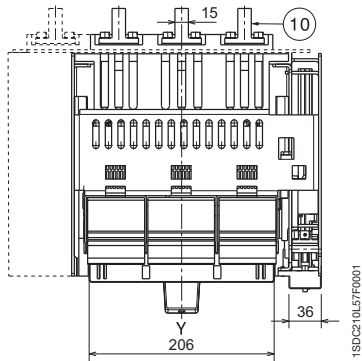

Rear flat horizontal - HR

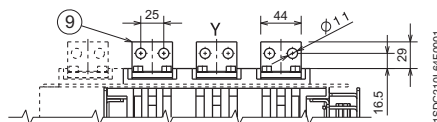

Rear spread terminal - RS

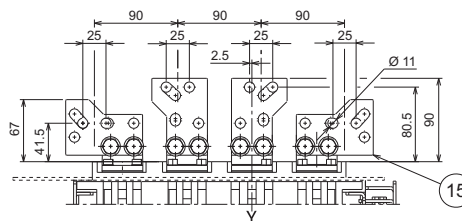
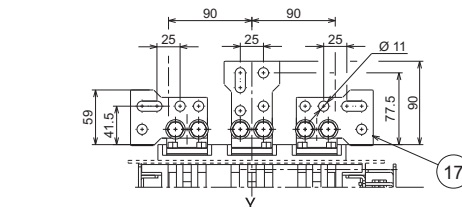

Caption

- ① Compartment door with flange sheet drilling
- ② Rear segregation for rear terminals
- ③ Compartment door flange
- ④ Flange fixing screws
- ⑤ Tightening torque: 1.5 Nm
- ⑥ Drilling template for fixing onto support sheet
- ⑦ Tightening torque: 21 Nm
- ⑧ Front terminals
- ⑨ Rear horizontal terminals
- ⑩ Rear vertical terminals
- ⑪ Rear segregation for front terminals
- ⑫ Flange for compartment door
- ⑬ Auxiliary contact terminal
- ⑭ Insulating protection
- ⑮ Rear spread terminals (4 poles)
- ⑯ Tightening torque 18 Nm
- ⑰ Rear spread terminals (3 poles)

Overall dimensions

Tmax T7M

Withdrawable circuit-breaker

Front extended - EF

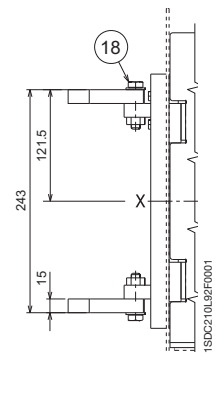
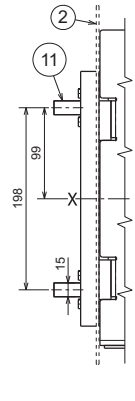
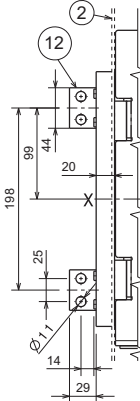
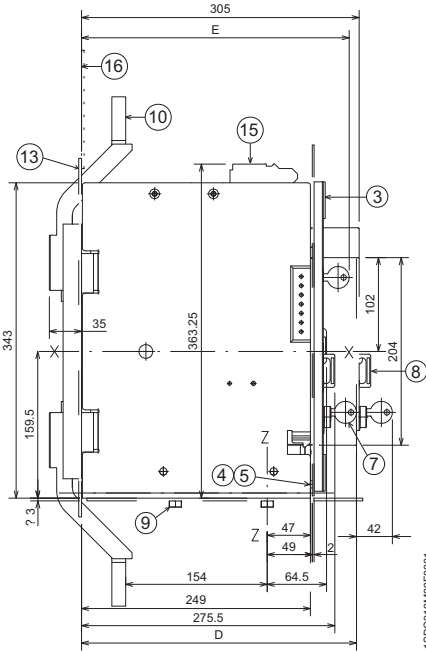
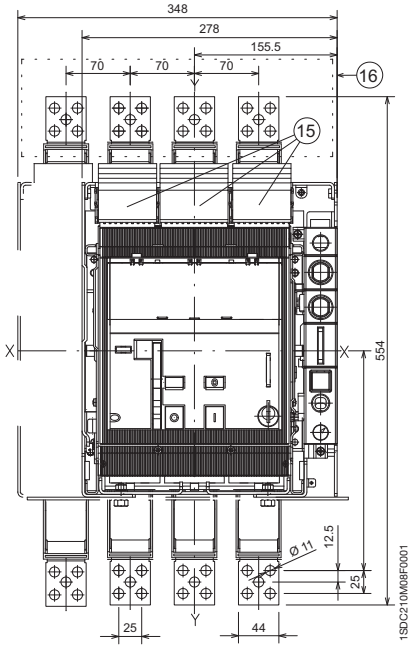

Rear flat vertical - VR

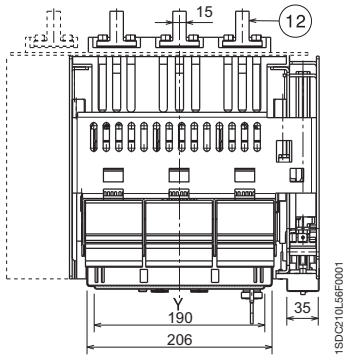

Rear flat horizontal - HR

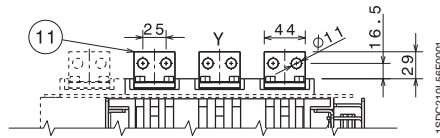

Rear spread terminal - RS

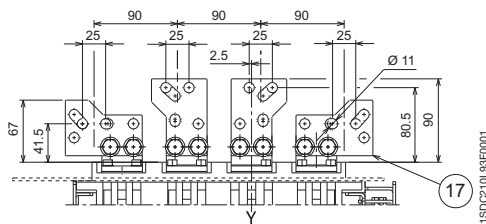
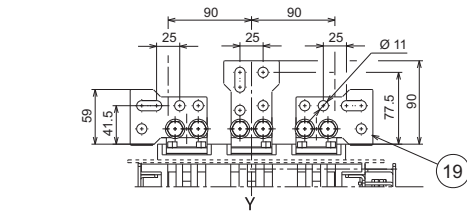

Caption

- ① Compartment door steel sheet drilling for flange
- ② Rear segregation for rear terminals
- ③ Flange for the compartment door
- ④ Flange fixing screws
- ⑤ Tightening torque: 1.5 Nm
- ⑦ Key lock (optional)
- ⑧ Padlock (optional)
- ⑨ Tightening torque: 21 Nm
- ⑩ Front terminal
- ⑪ Rear horizontal terminal
- ⑫ Rear vertical terminal
- ⑬ Rear segregation for front terminals
- ⑭ Flange for compartment door
- ⑮ Overall dimensions of the auxiliary contact terminals
- ⑯ Insulating protection
- ⑰ Rear spread terminals (4 poles)
- ⑱ Tightening torque 18 Nm
- ⑲ Rear spread terminals (3 poles)

Overall dimensions

Circuit-breaker with RC221/222 residual current release

Tmax T1 with RC222 for 200 mm module

Fixed version

Caption

- ① Depth of the switchboard with circuit-breaker face extending
- ② Depth of the switchboard with circuit-breaker face flush with door
- ③ Terminal covers with degree of protection IP40

Front terminals - F

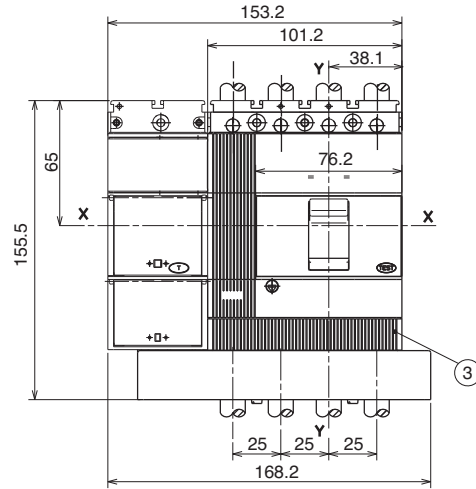

Fixing on sheet

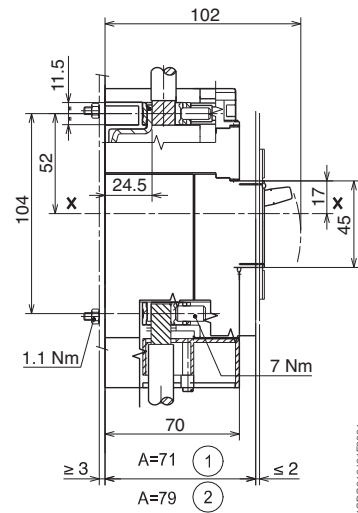

Drilling templates of the compartment door

For A = 71 - without flange

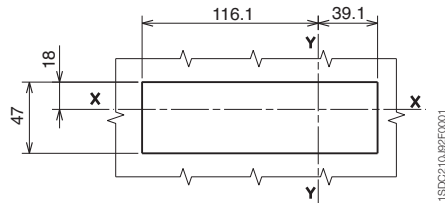

For A = 79 - without flange

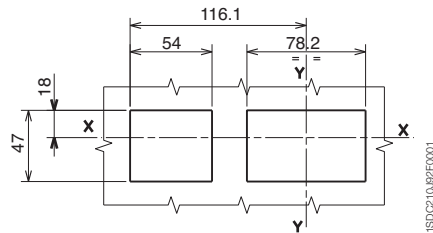

Drilling templates for support sheet

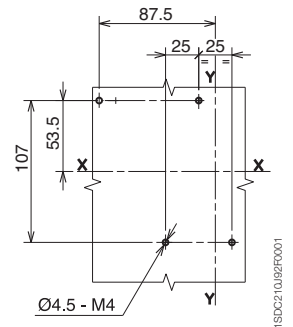

Overall dimensions

Circuit-breaker with RC221/222 residual current release

Tmax T1 - T2 - T3

Fixed version

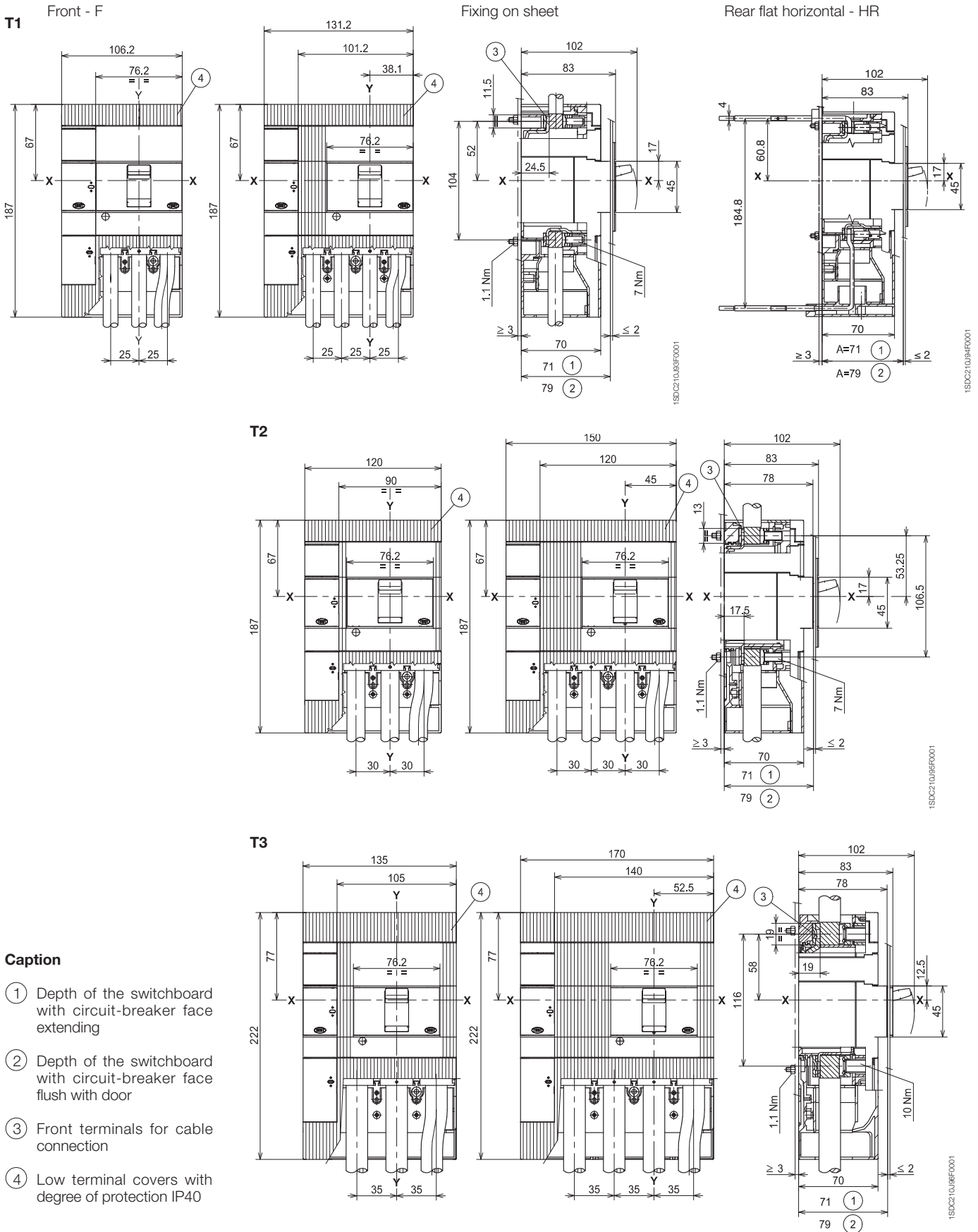

Fixed version

Flange for the compartment door

T1

T2

T3

3 POLES

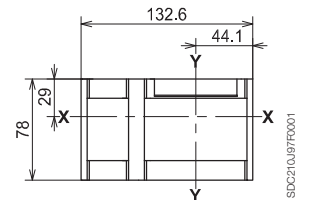
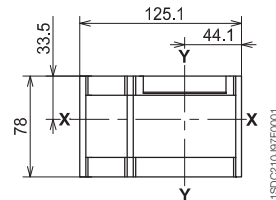
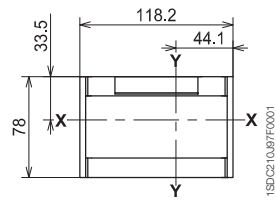

4 POLES

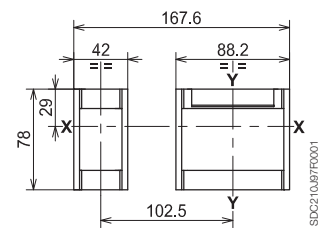
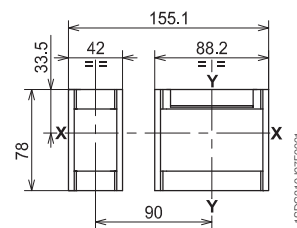
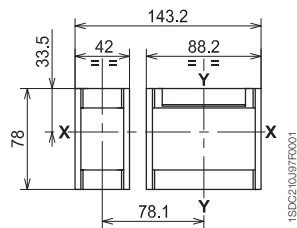

Drilling template for fixing sheet

T1 - T2 - T3

3 POLES

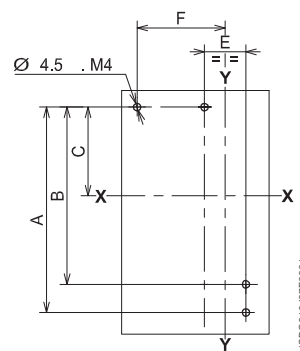

4 POLES

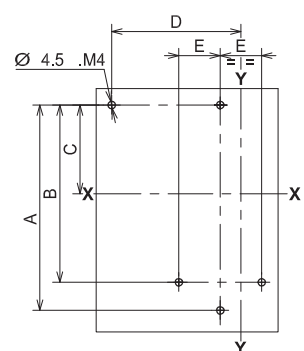

T1 rear flat horizontal - HR

4 POLES

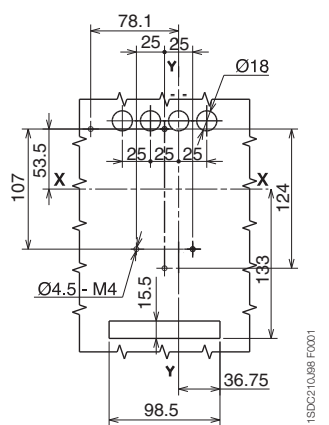

	A	B	C	D	E	F
T1	124	107	53.5	78.1	25	53.1
T2	124	107	53.5	90	30	60
T3	141.5	122	61	102.5	35	67.5

Overall dimensions

Circuit-breaker with RC221/222 residual current release

Tmax T1 - T2 - T3

Drilling templates of the compartment door

Without flange
face extending

3 POLES

T1 - T2 - T3

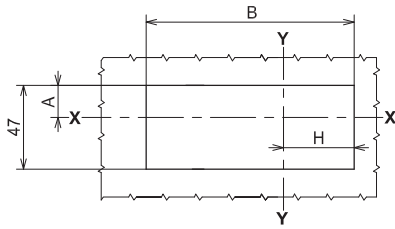

Without flange
face not extending

T1

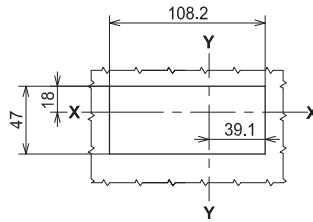

With flange
face not extending

T1 - T2 - T3

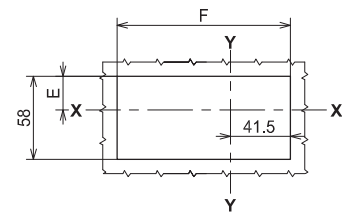

4 POLES

T1 - T2 - T3

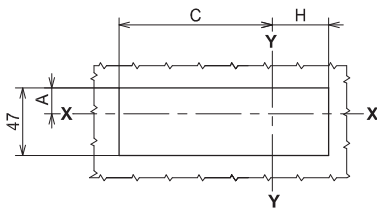

T2 - T3

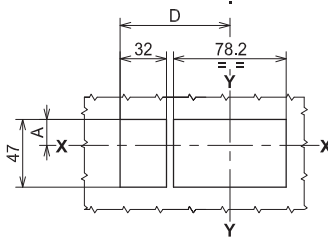

T1 - T2 - T3

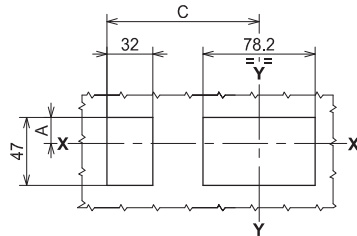

T1 - T2 - T3

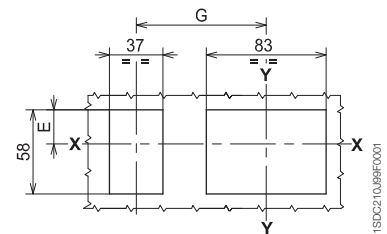

	A	B	C	D	E	F	G	H
T1	18	108.2	94.1	-	23.5	113	78.1	39.1
T2	18	122	106	76	23.5	120	90	46
T3	13.5	137	118.5	83.5	19	127.4	102.5	53.5

1SDC210099F001

Overall dimensions

Circuit breaker with RC223 residual current release
Tmax T3

Fixed version

Caption Front terminals with residual current

- ① Front terminals for bars connection
- ② Fixing on sheet steel
- ③ Compartment door sheet steel drilling
- ④ Tightening torque 1.1 Nm
- ⑤ Tightening torque 2 Nm
- ⑥ Tightening torque 8 Nm

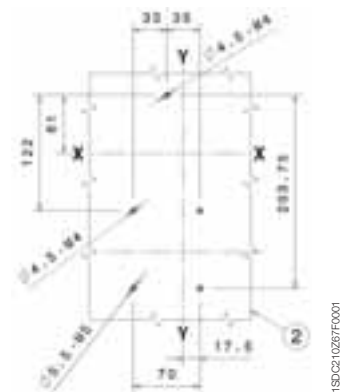
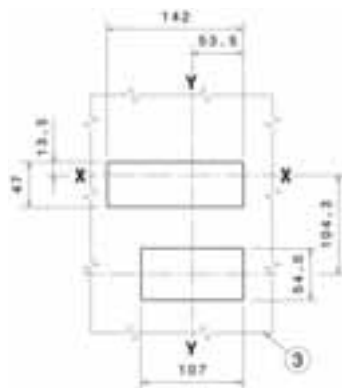
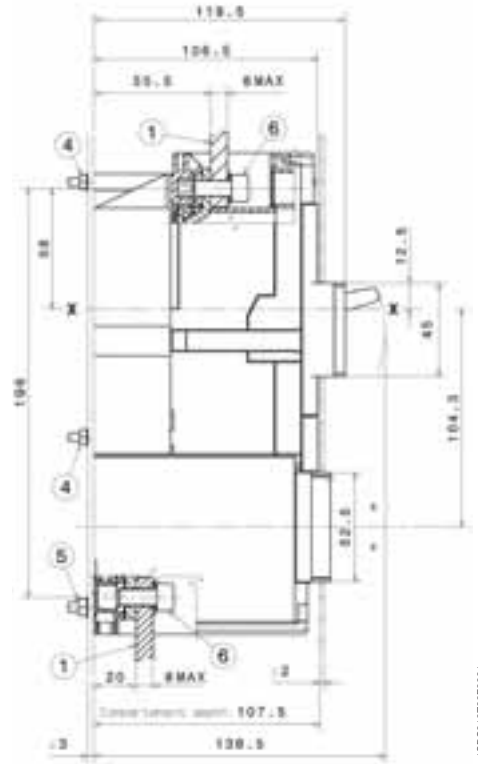
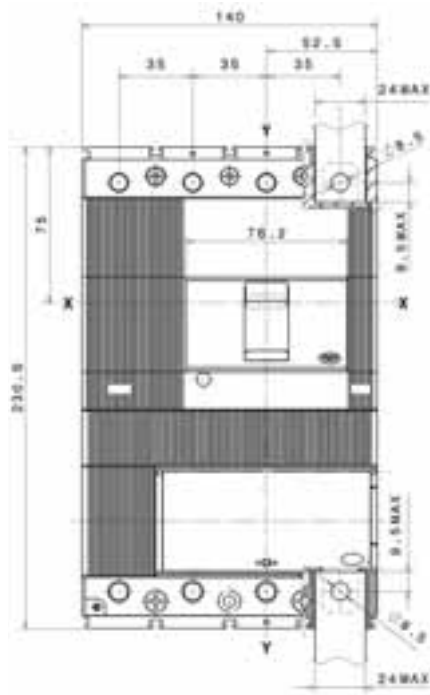

Overall dimensions

Circuit-breaker with RC222 residual current release

Tmax T4 - T5

Fixed version

Front - F, fixing on sheet

T4

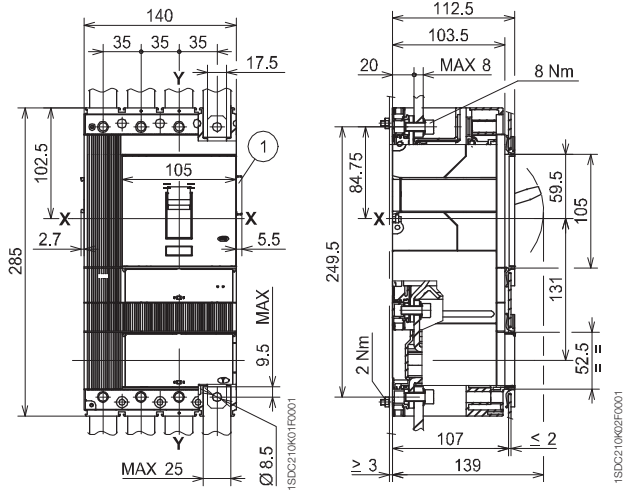

T5 (400 A)⁽¹⁾

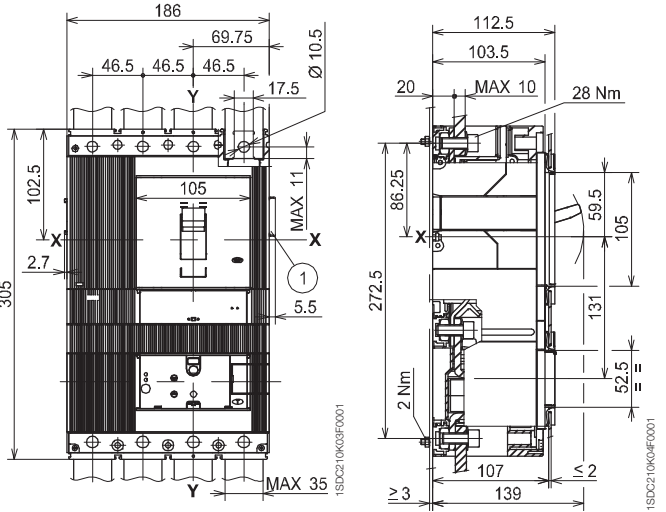

Caption

- ① Overall dimensions with cabled auxiliary contacts mounted (only 3Q 1SY)

⁽¹⁾ For T5 (630 A) ask ABB SACE

Flange for the compartment door

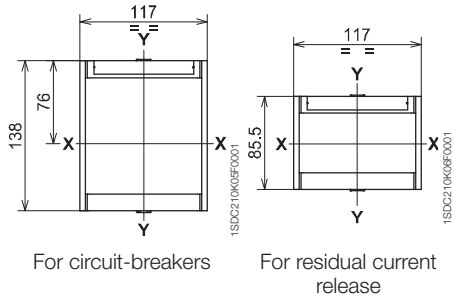

For circuit-breakers

For residual current release

Drilling templates of compartment door and fitting flange

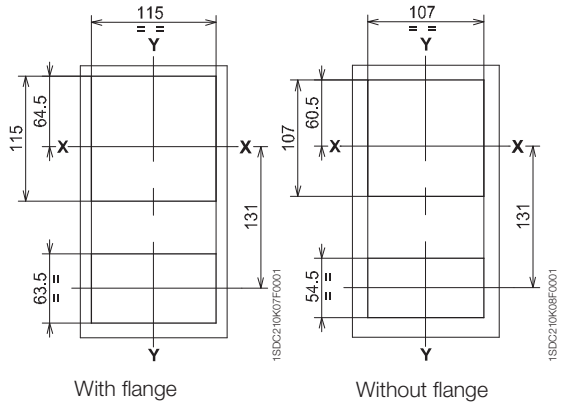

With flange

Without flange

Overall dimensions

Accessories for Tmax T1 - T2 - T3

Fixed version

Solenoid operator superimposed

T1

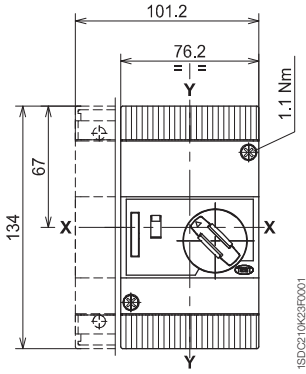

T2

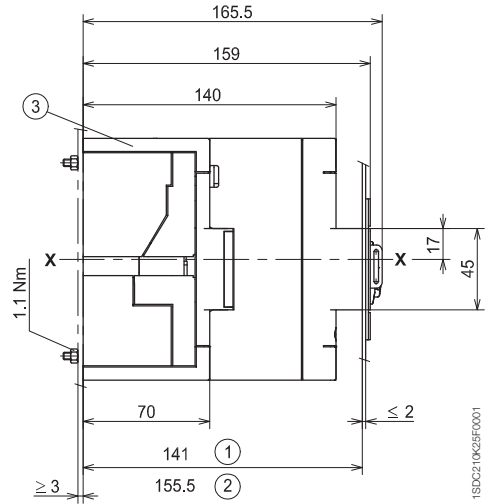
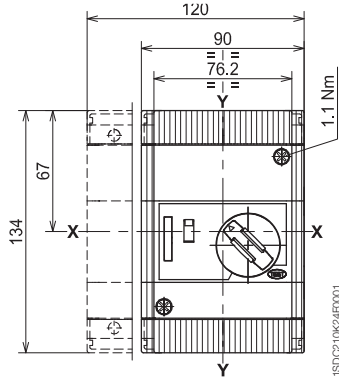

Caption

- ① Depth of the switchboard with operating mechanism face extending
- ② Depth of the switchboard with operating mechanism face flush with door
- ③ Low terminal covers with degree of protection IP40

T3

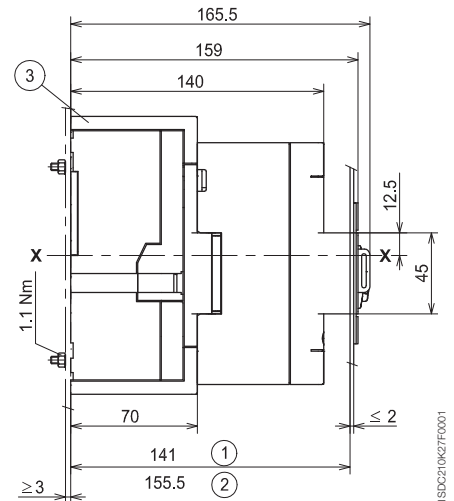
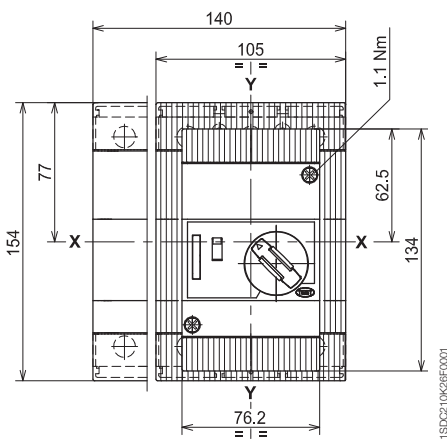

Flange for compartment door

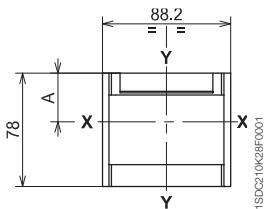

Drilling templates of the compartment door

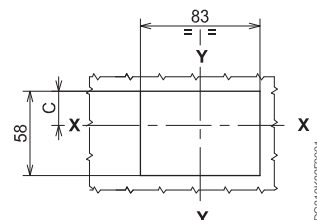
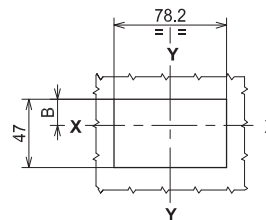
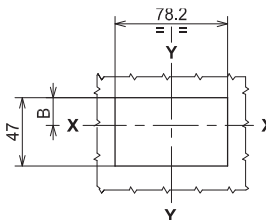

	A	B	C
T1	33.5	18	23.5
T2	33.5	18	23.5
T3	29	13.5	19

Without flange
Operating mechanism face extending

Without flange
Operating mechanism face flush with door

With flange
Operating mechanism face flush with door

Overall dimensions

Accessories for Tmax T1 - T2 - T3

Fixed version

Solenoid operator side by side

Caption

- ① Circuit-breaker face extending
- ② Circuit-breaker face flush with door
- ③ Low terminal covers with degree of protection IP40

T1

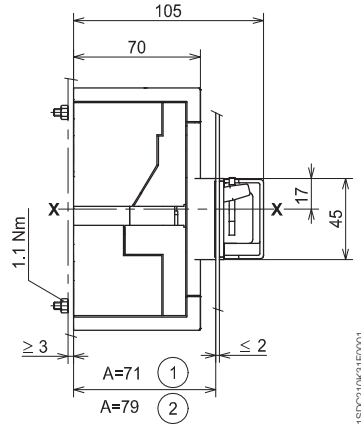
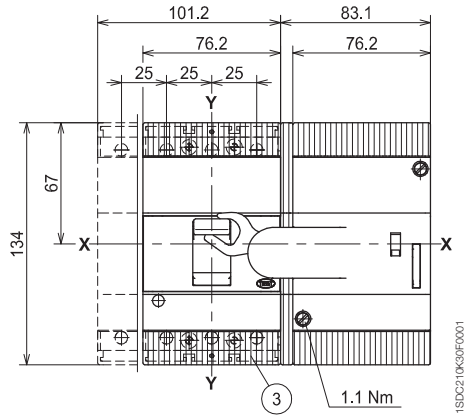

Drilling templates for fixing sheet

Drilling templates of the compartment door

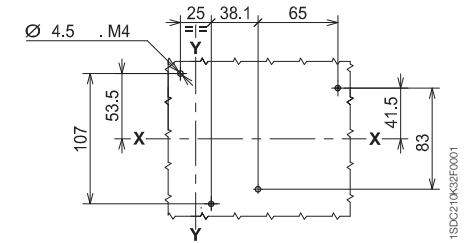

3 POLES

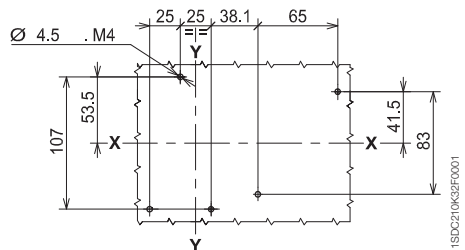
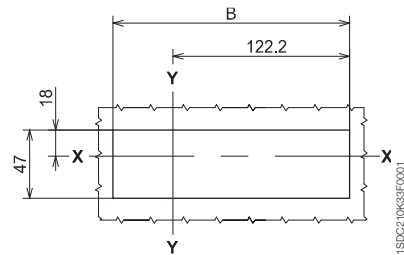

4 POLES

	A	B
3P	79	161.3
	71	161.3
4P	79	161.3
	71	186.3

Caption

- ① Circuit-breaker face extending
- ② Circuit-breaker face flush with door
- ③ Low terminal covers with degree of protection IP40

Solenoid operator side by side

T2

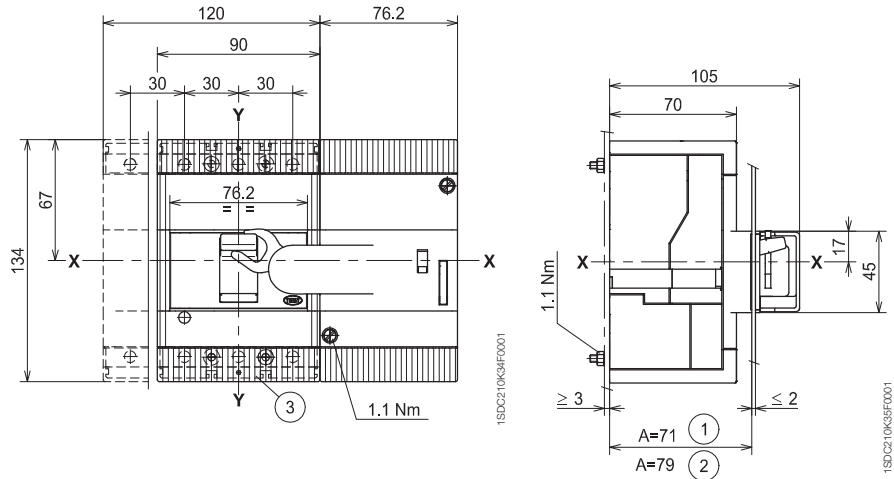

Drilling templates for fixing sheet

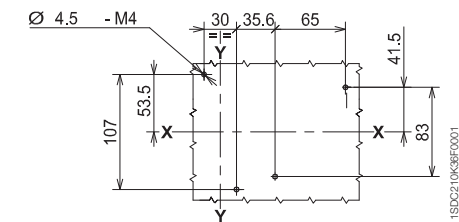

3 POLES

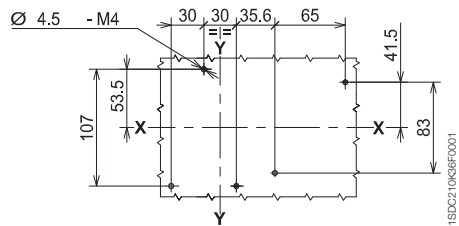

4 POLES

Drilling templates of the compartment door

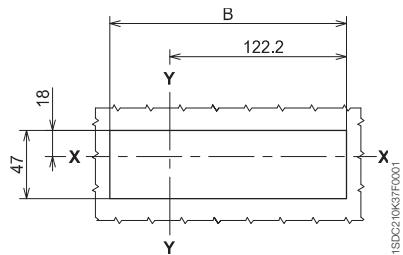

	A	B
3P	79	161.3
	71	161.3
4P	79	161.3
	71	198.2

Overall dimensions

Accessories for Tmax T1 - T2 - T3

Fixed version

Rotary handle operating mechanism on the compartment door

Caption

- ① Transmission unit
- ② Rotary handle operating mechanism on the compartment door

	A	B
T1-T2	28	14
T3	32.5	9.5

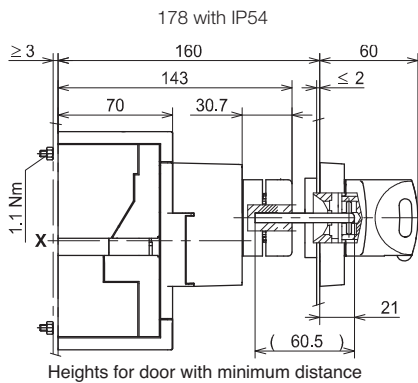
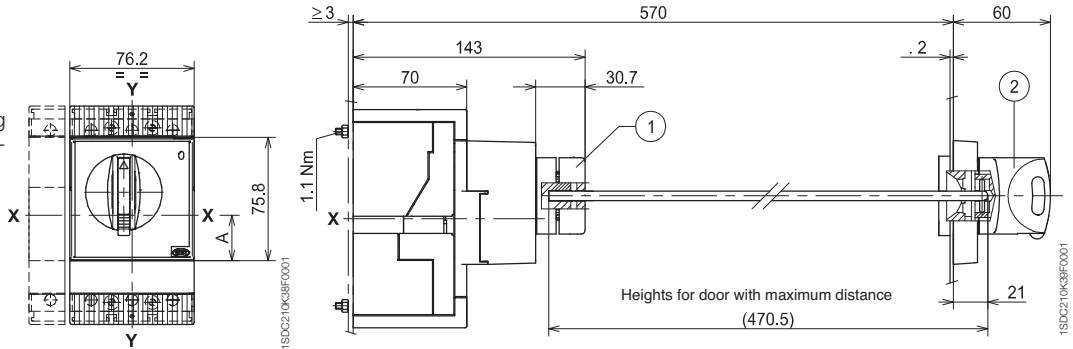

Drilling template of the compartment door

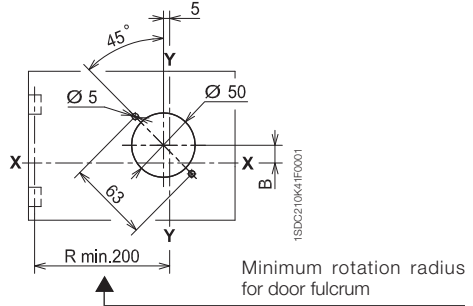

Caption

- ① Rotary handle operating mechanism on circuit-breaker

	A	B	C	D
T1-T2	67.7	28	53.2	60.5
T3	63.2	32.5	48.7	56

Rotary handle operating mechanism on circuit-breaker

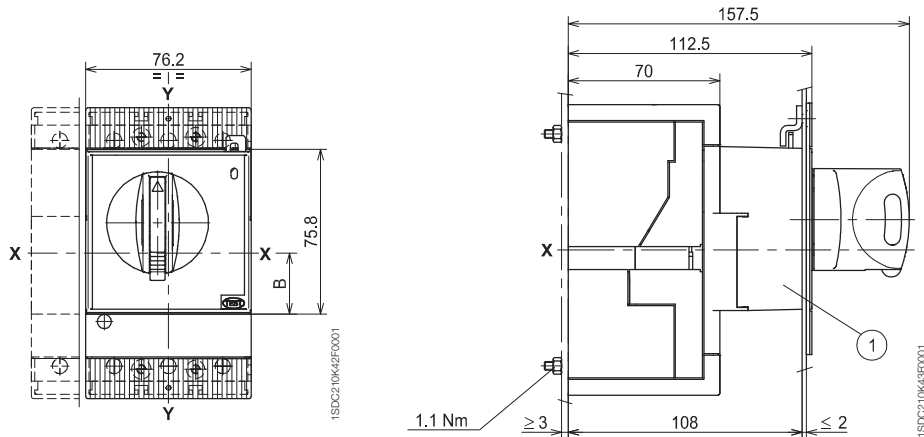

Drilling template of the compartment door

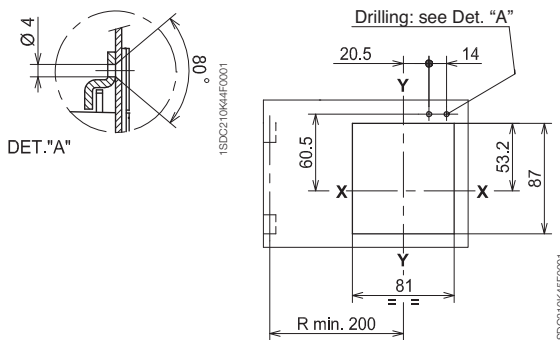

Flange for the compartment door

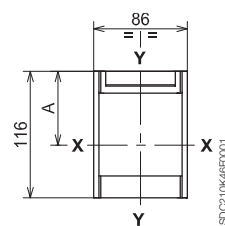

Mechanical interlock between circuit-breakers

Front interlocking plate between two circuit-breakers

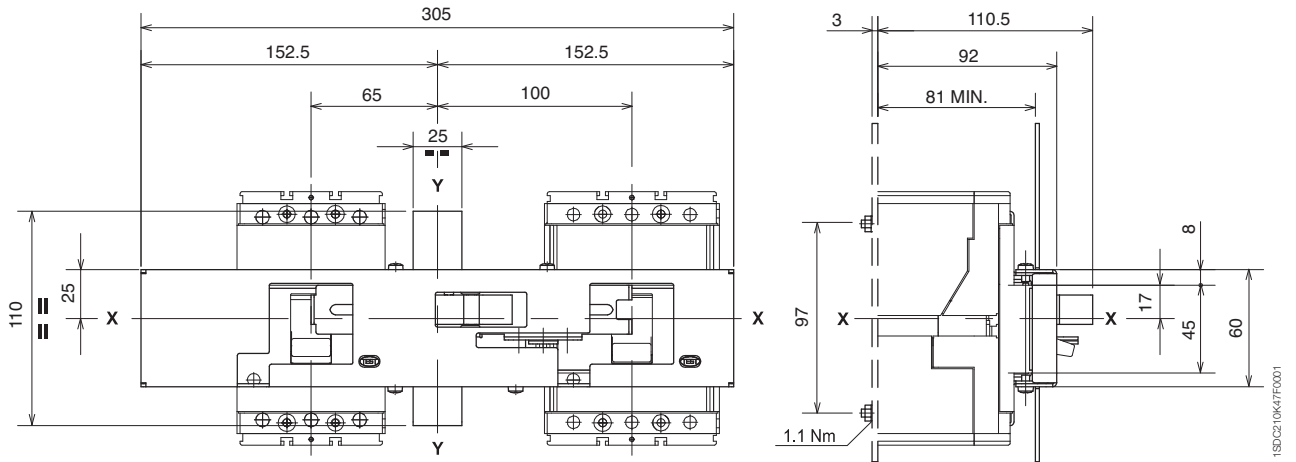

Caption

- ① Drilling templates of the compartment door
- ② Drilling templates for support sheet

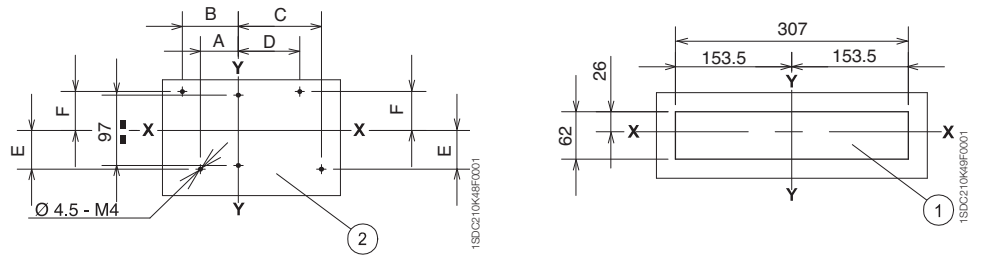

Front interlocking plate between three circuit-breakers

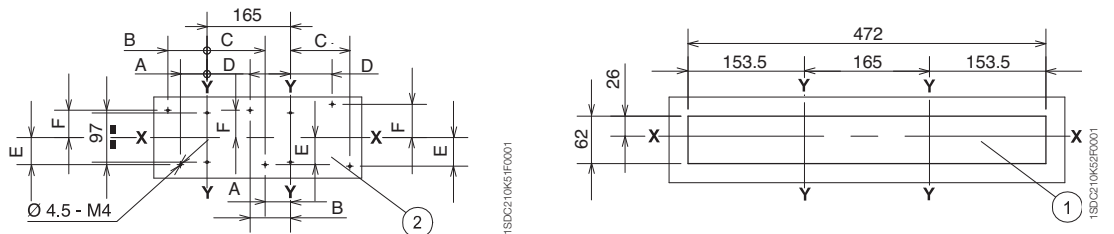
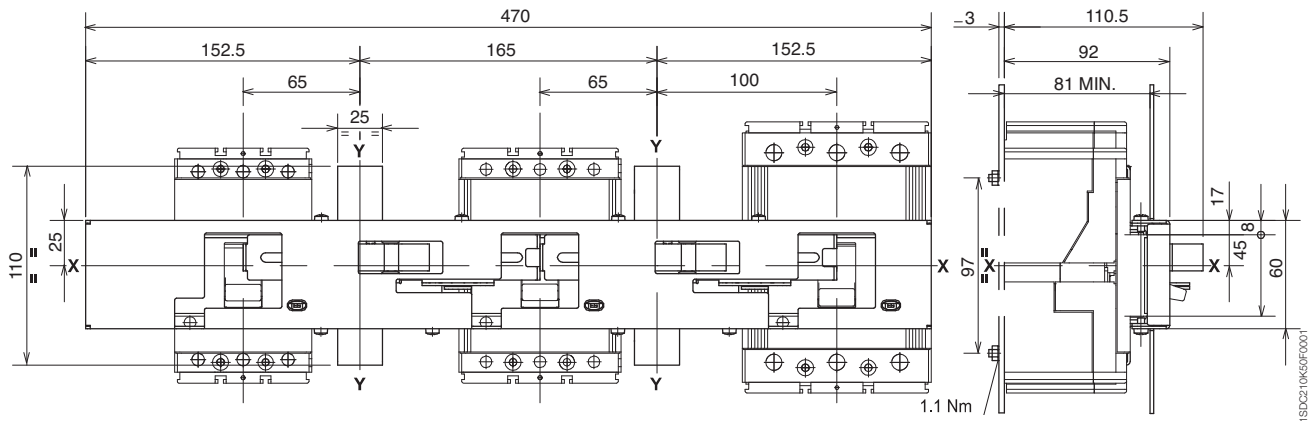

	A	B	C	D	E	F
T1	52.5	77.5	112.5	87.5	53.5	53.5
T2	50	80	115	85	53.5	53.5
T3	47.5	82.5	117.5	82.5	56.5	65.5

Caption

- ① IP 42 protection
- ② Compartment door sheet steel drilling

Protection kit IP 42 for T1 fixed

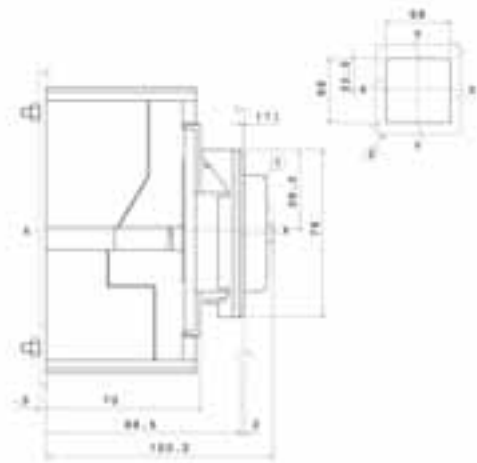
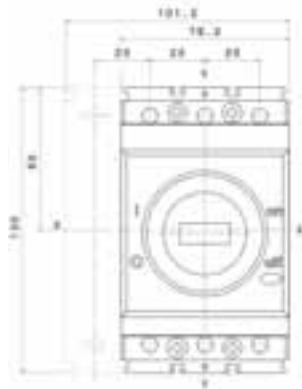

1SDC210274F0001

Caption

- ① IP 42 protection
- ② Compartment door sheet steel drilling

Protection kit IP 42 for T2 fixed

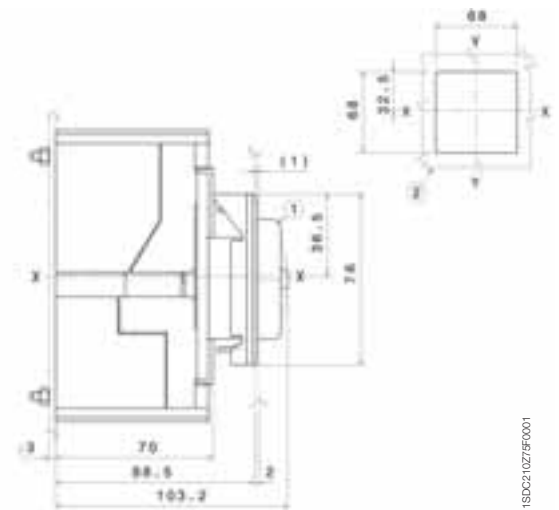
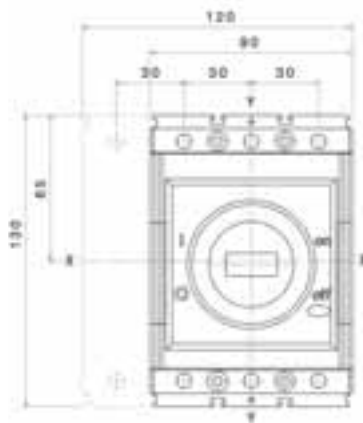

1SDC210275F0001

Caption

- ① IP 42 protection
- ② Compartment door sheet steel drilling

Protection kit IP 42 for T3 fixed

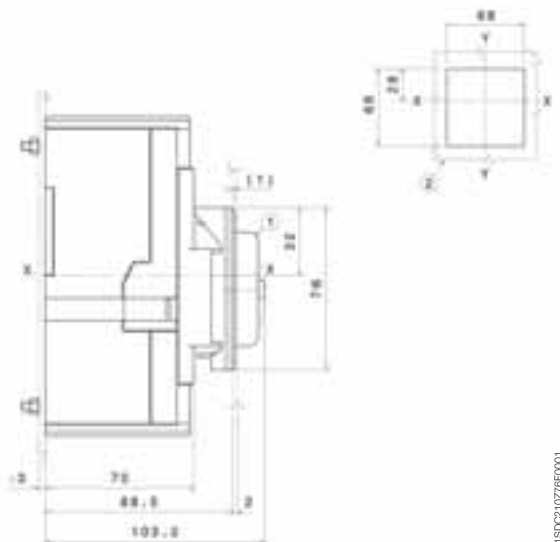
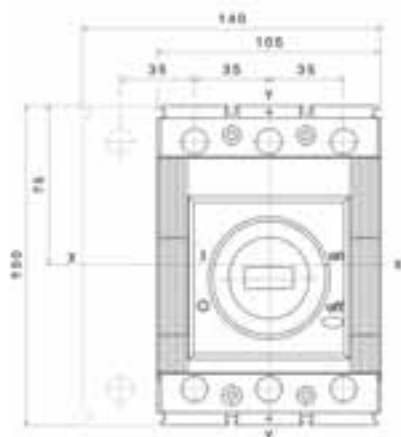

1SDC210276F0001

Overall dimensions

Accessories for Tmax T4 - T5

Fixed version

Rotary handle operating mechanism on the compartment door

Caption

- ① Transmission unit
- ② Rotary handle assembly with door lock device
- ③ Padlock device for open position (maximum 3 padlocks to be provided by the user)
- ④ IP54 protection (supplied on request)
- ⑤ Min...max distance from the front of the door without accessory ④
- ⑥ Min...max distance from the front of the door with accessory ④
- ⑦ Dimension with AUE connector (early making contact)

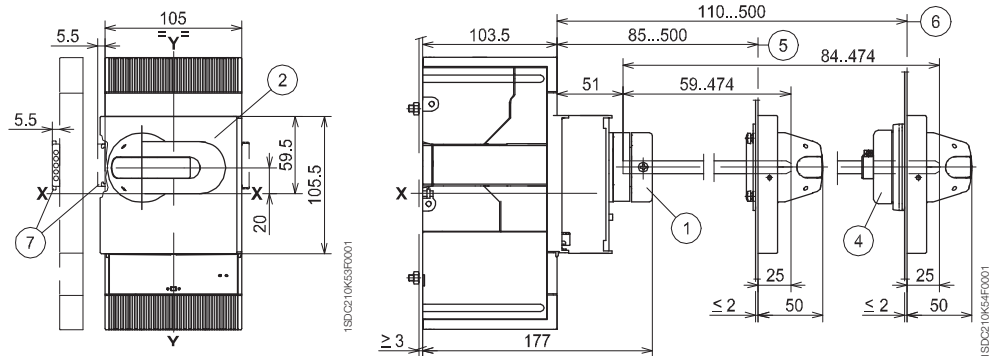

Drilling of compartment door

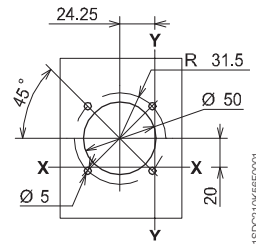

Caption

- ① Rotary handle operating mechanism on circuit-breaker
- ② Padlock device for open position (maximum 3 padlocks to be provided by the user)
- ③ Dimension with AUE connector (early making contact)
- ④ Compartment door lock

Rotary handle operating mechanism on circuit-breaker

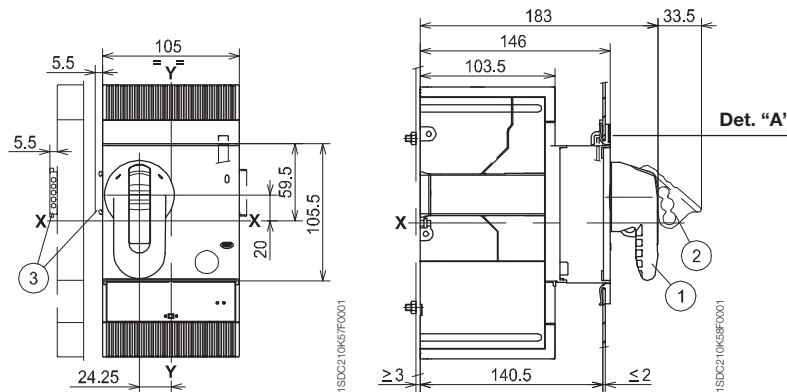

Drilling template of the compartment door

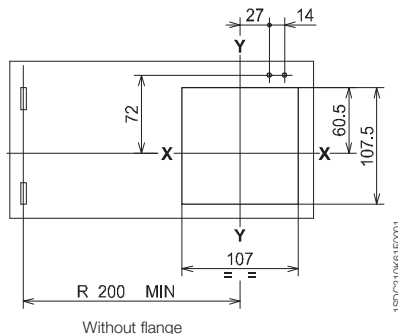
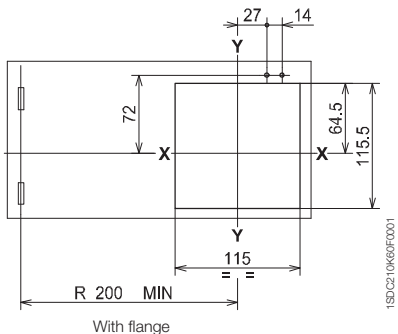

Flange for the compartment door

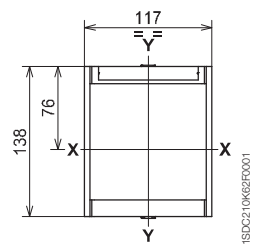

Caption

- ① Overall dimensions with cabled auxiliary contacts mounted (only 3Q 1SY)

Motor operator

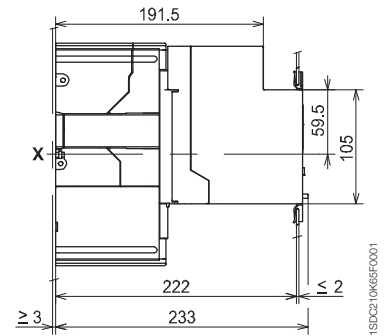
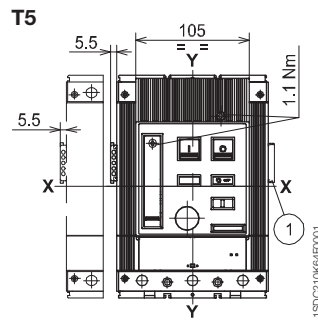
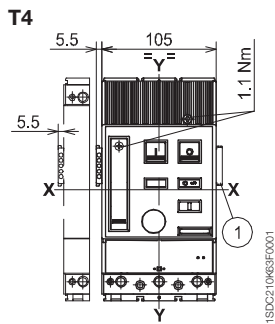

Flange for the compartment door (supplied as standard)

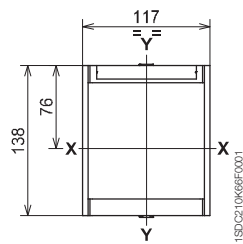

Drilling template of the compartment door

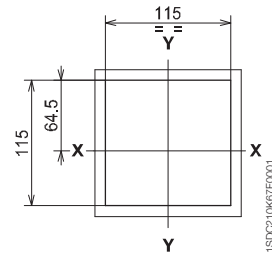

With flange

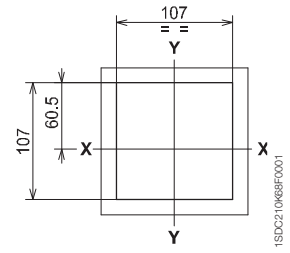

Without flange

Drilling template for support sheet

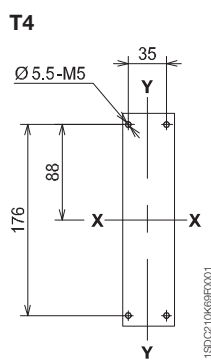

3 POLES

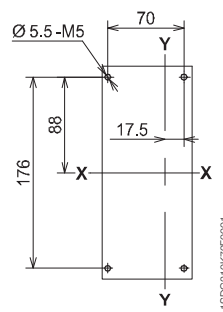

4 POLES

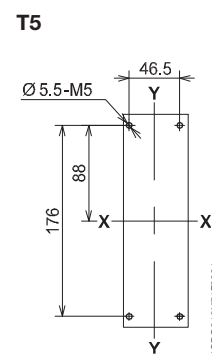

3 POLES

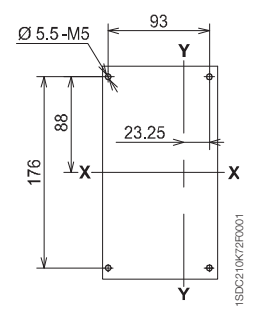

4 POLES

Overall dimensions

Accessories for Tmax T4 - T5

Fixed version

Caption

- ① Front for lever operating mechanism
- ② Lock for the compartment door (supplied on request)

Front for lever operating mechanism

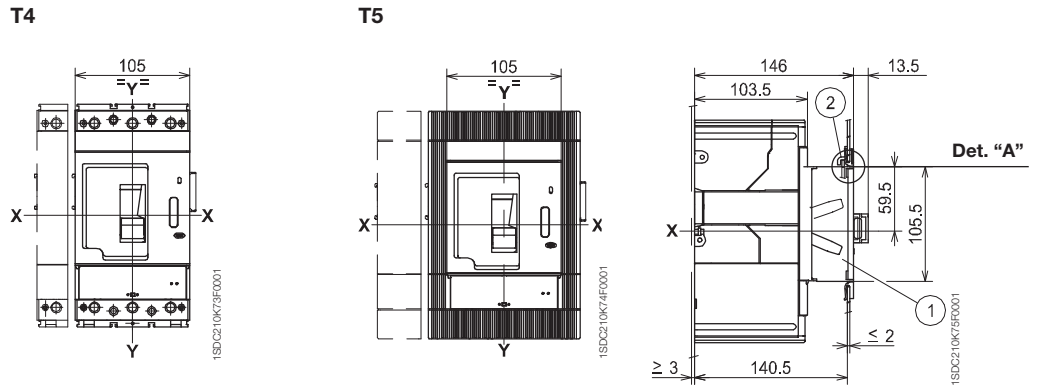

Flange for the compartment door (supplied as standard)

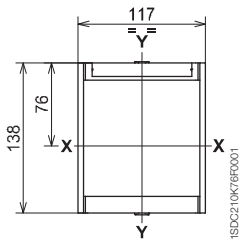

Drilling template for the compartment door

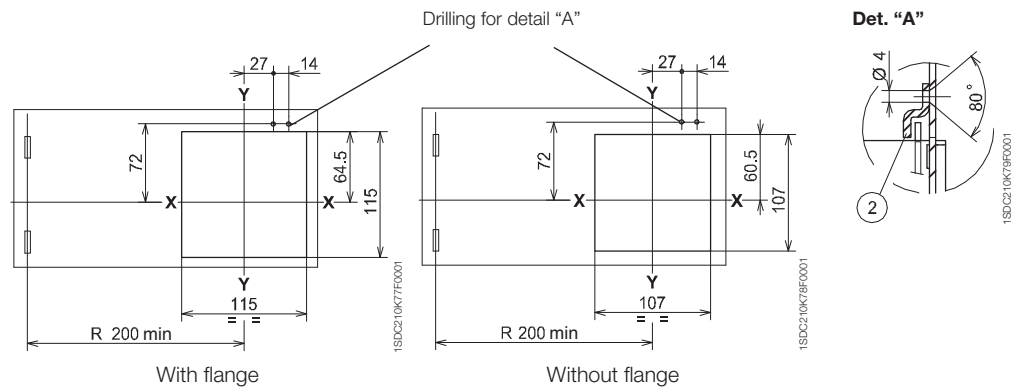

Drilling template for support sheet

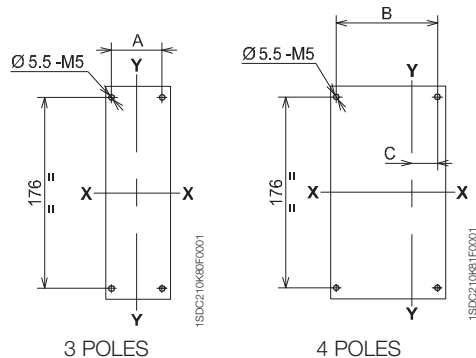

	A	B	C
T4	35	70	17.5
T5	46.5	93	23.25

Caption

Interlock between two circuit-breakers placed side by side

- ① Interlocking mechanism
- ② Circuit-breaker coupling plate

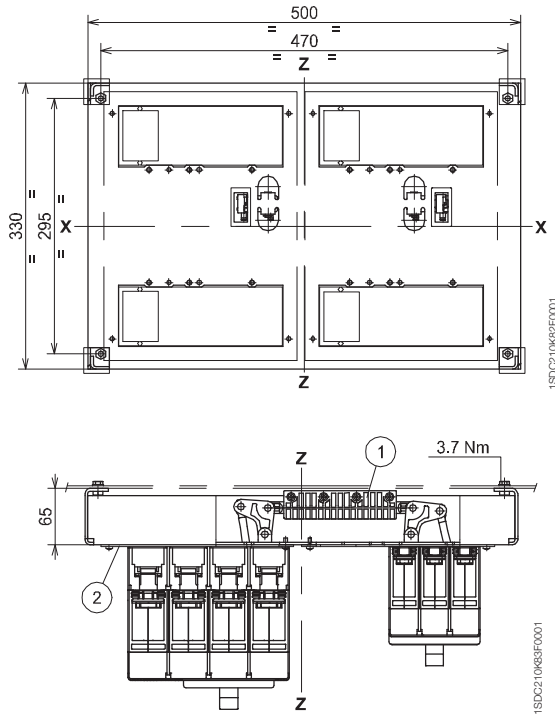

Caption

Drilling templates for fixing the circuit-breaker on the support sheet

- ① Drilling template for all versions with rear terminals

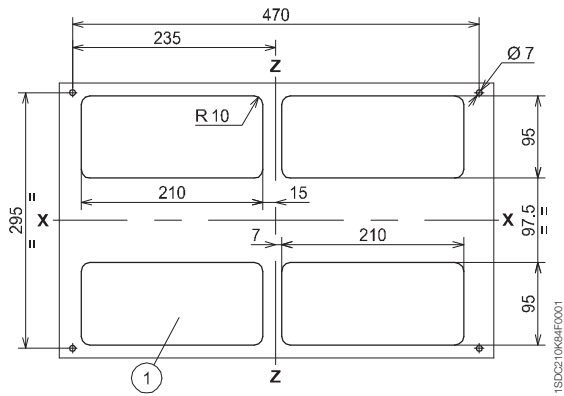

Overall dimensions

Accessories for Tmax T4 - T5

Fixed version

Interlock between two circuit-breakers placed side by side

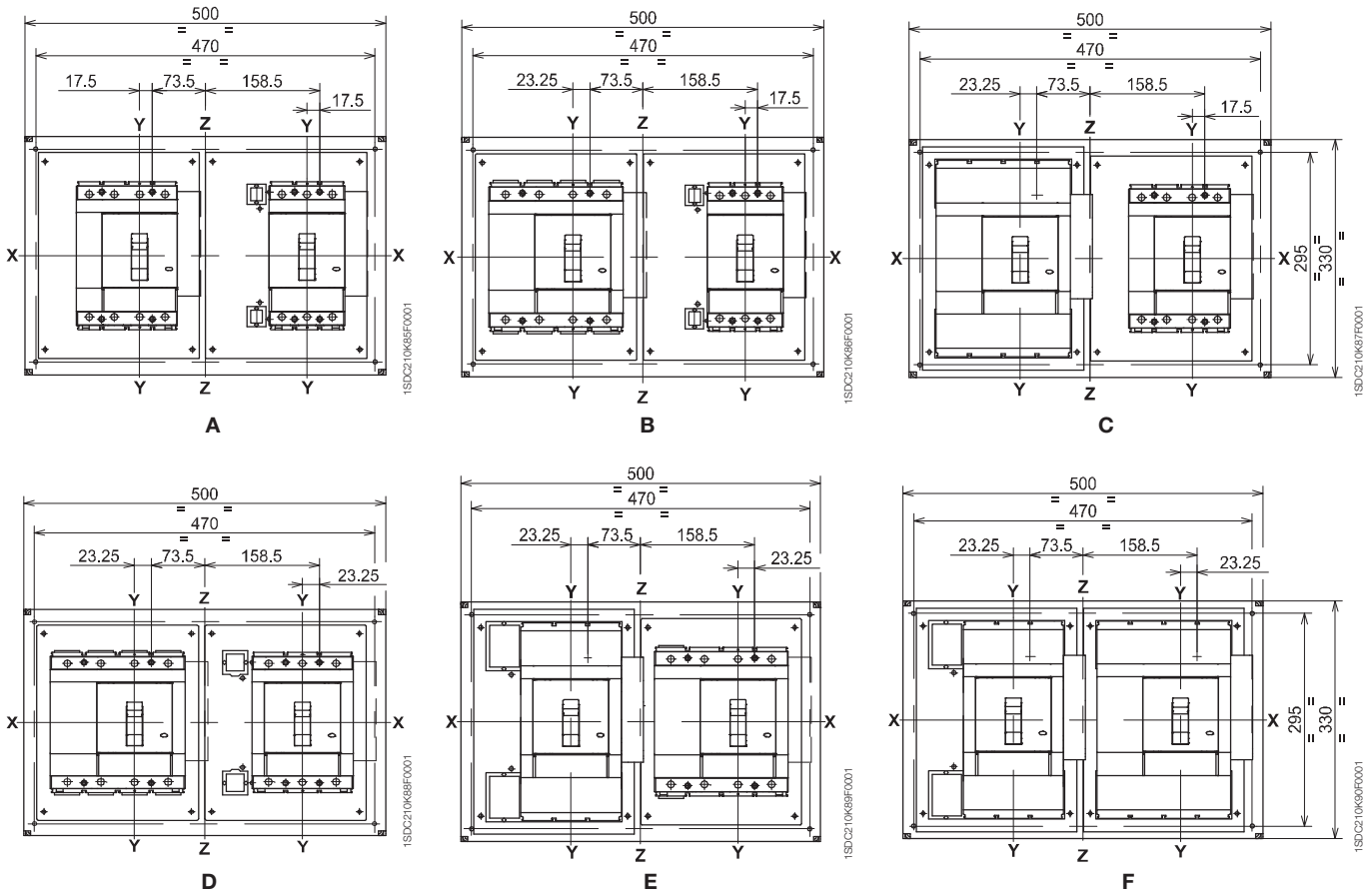

Type	Circuit-breakers
A	N° 1 T4 (F-P-W) N° 1 T4 (F-P-W)
B	N° 1 T4 (F-P-W) N° 1 T5 400 (F-P-W) or T5 630 (F)
C	N° 1 T4 (F-P-W) N° 1 T5 630 (P-W)
D	N° 1 T5 400 (F-P-W) or T5 630 (F) N° 1 T5 400 (F-P-W) or T5 630 (F)
E	N° 1 T5 400 (F-P-W) or T5 630 (F) N° 1 T5 630 (P-W)
F	N° 1 T5 630 (P-W) N° 1 T5 630 (P-W)

Note:
 (F) Fixed circuit-breaker
 (P) Plug-in circuit-breaker
 (W) Withdrawable circuit-breaker

Withdrawable version

Motor operator

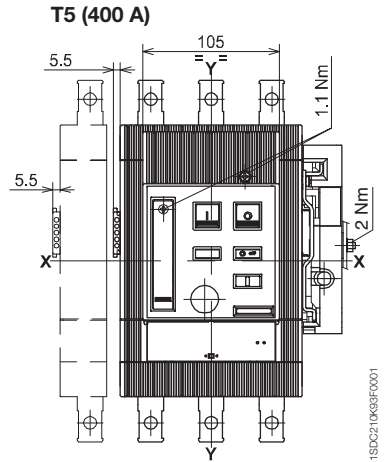
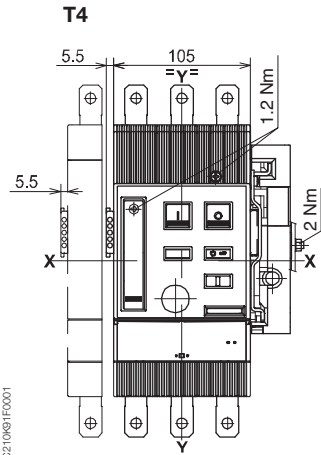
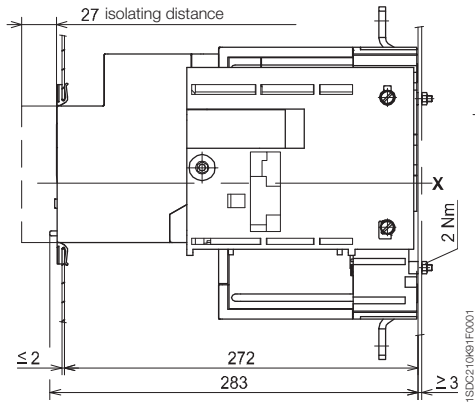

T5 (630 A)

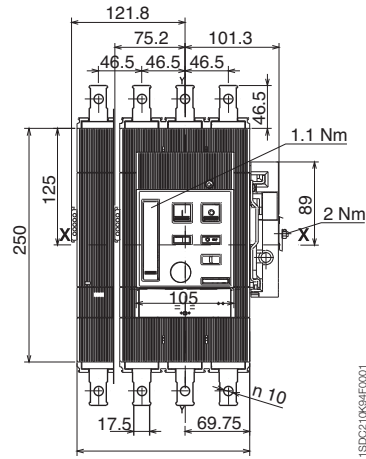
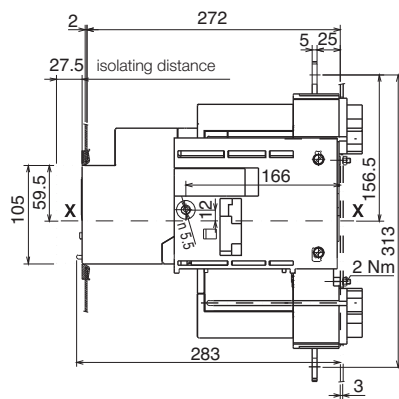

Flange for the compartment door (supplied as standard)

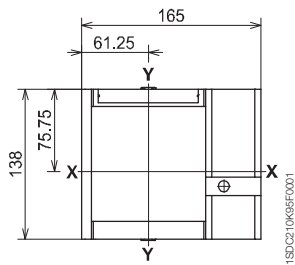

Drilling templates for the compartment door and fitting flange

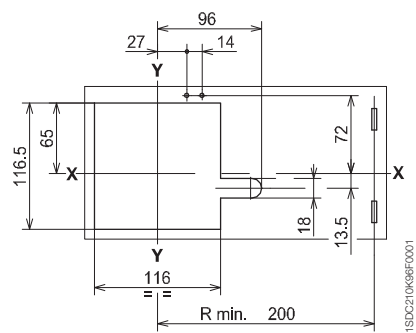

Overall dimensions

Accessories for Tmax T4 - T5

Withdrawable version

Caption

- ① Padlock device for open position (maximum 3 padlocks to be provided by the user)
- ② Lock for compartment door
- ③ Dimension with AUE connector (early making contact)

Rotary handle operating mechanism on the circuit-breakers

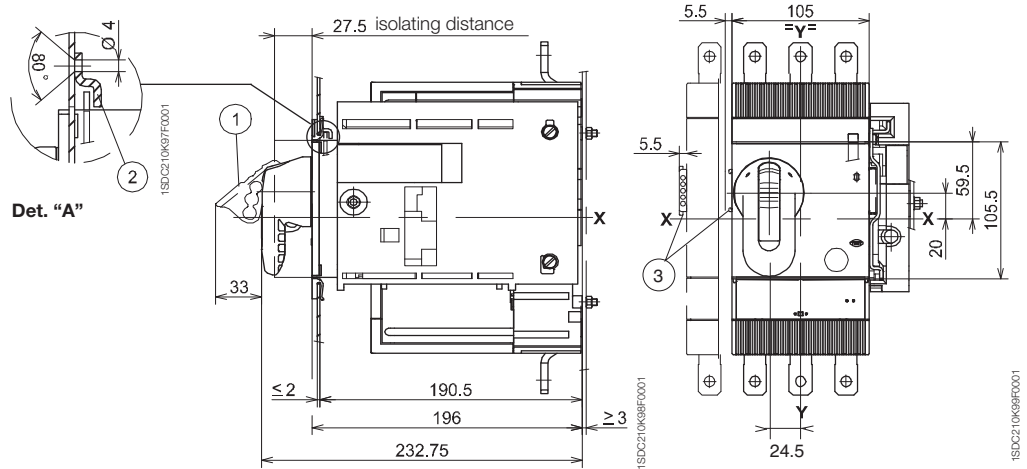

Flange for the compartment door

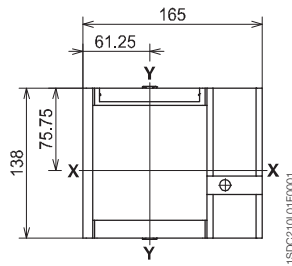

Drilling template for compartment door and fitting flange

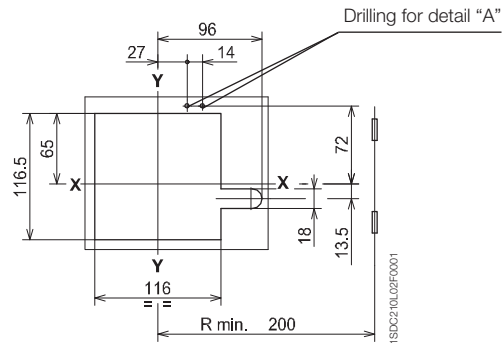

Caption

Protection kit IP42 for T4 fixed

- ① IP42 protection
- ② Compartment door sheet steel drilling
- ③ Spacing when equipped with SOR-C, UVR-C, RC221-222

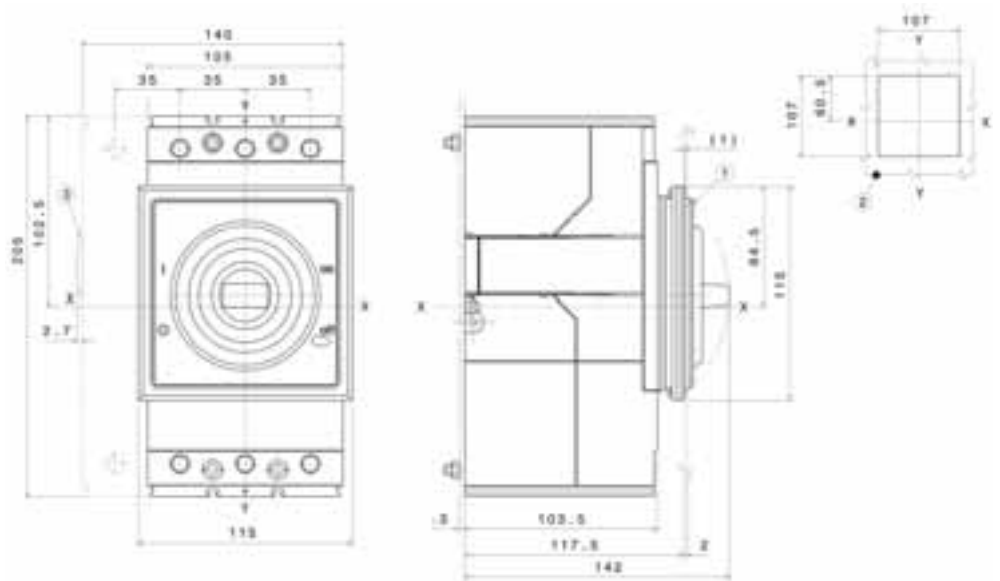

1SDC210286F001

Caption

Protection kit IP42 for T5 fixed

- ① IP42 protection
- ② Compartment door sheet steel drilling
- ③ Spacing when equipped with SOR-C, UVR-C, RC221-222
- ④ Spacing when equipped with AUX-C (3Q 1SY only)

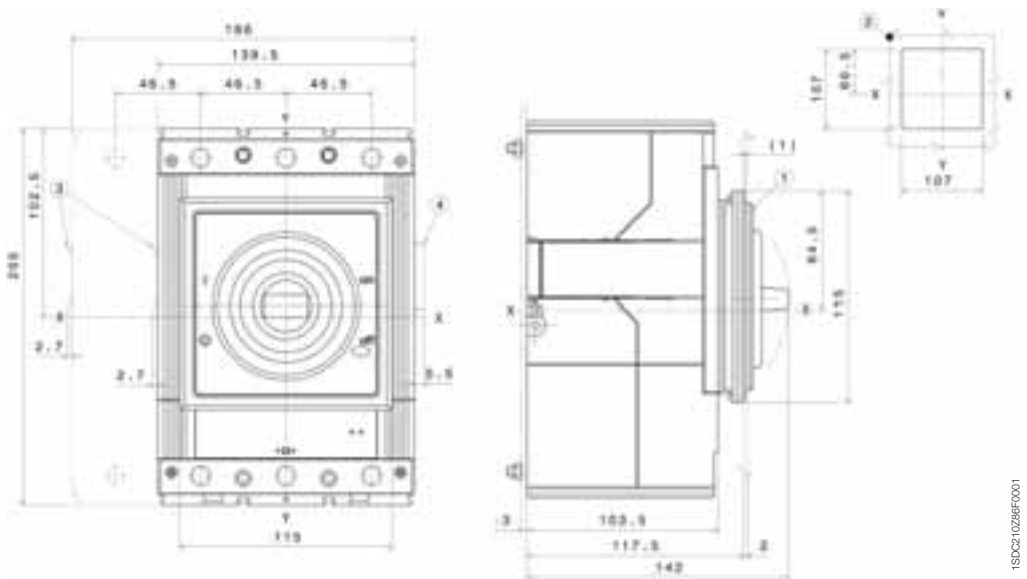

1SDC210286F001

Fixed version

Motor operator

Caption

- ① Overall dimensions with cabled auxiliary contacts mounted (only 3Q 1SY)

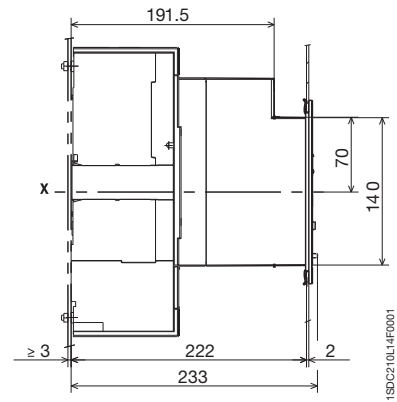
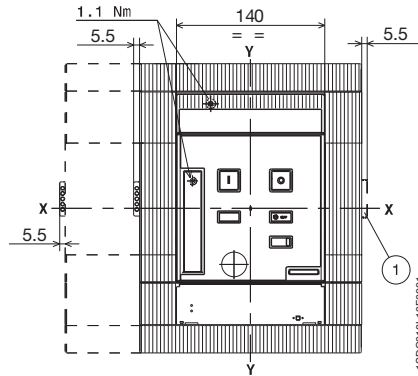

Flange for the compartment door (supplied as standard)

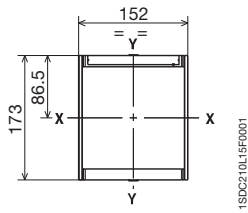

Drilling template of the compartment door

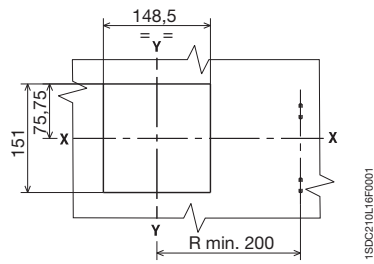

With flange

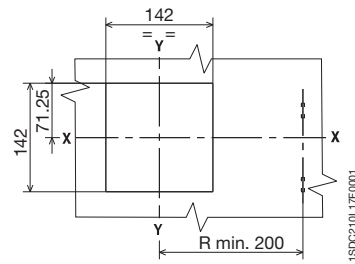

Without flange

Drilling template for support sheet

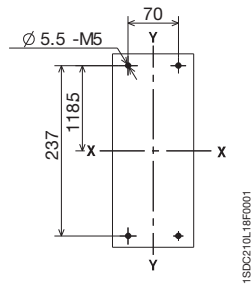

3 POLES

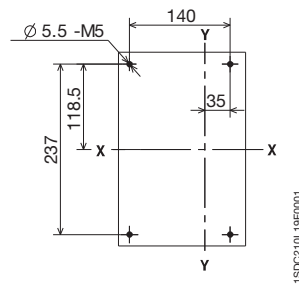

4 POLES

Overall dimensions

Accessories for Tmax T6

Caption

- ① Front for lever operating mechanism
- ② Lock for the compartment door

Front for lever operating mechanism

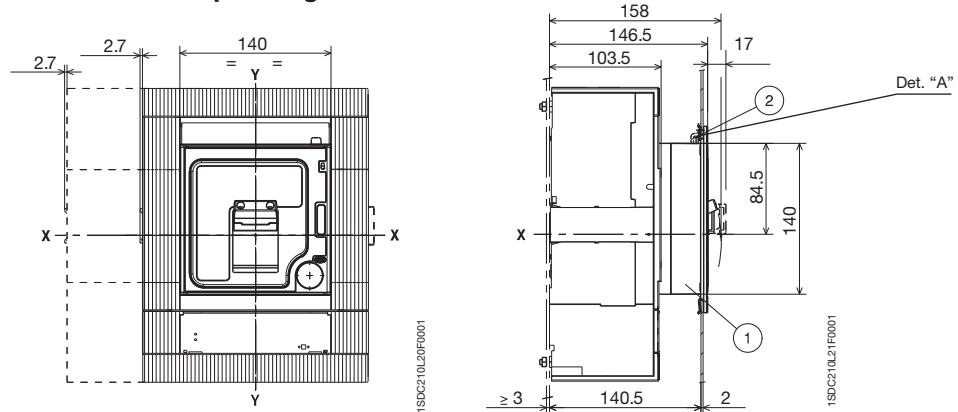

Flange for the compartment door (supplied as standard)

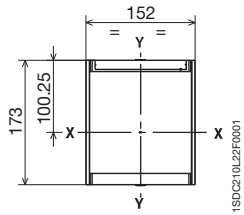

Drilling template for the compartment door

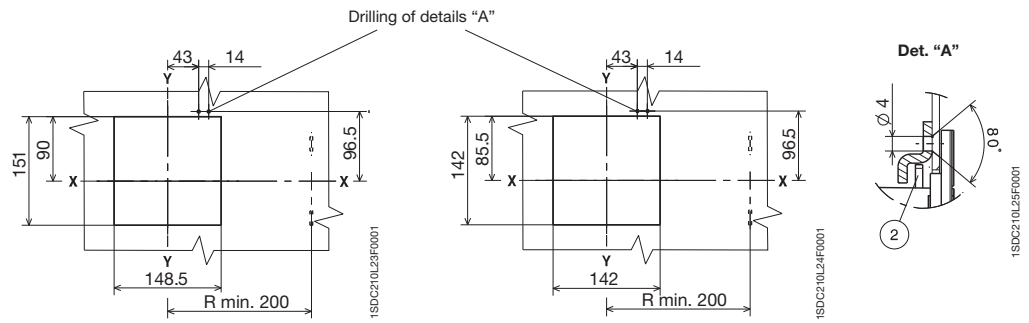

Drilling template for support sheet

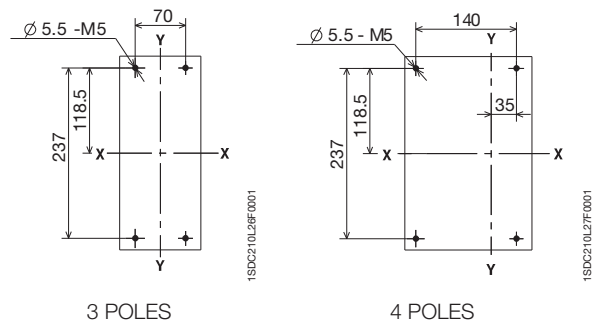

Withdrawable version

Motor operator

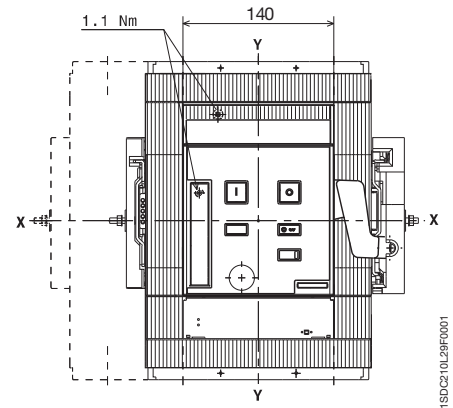
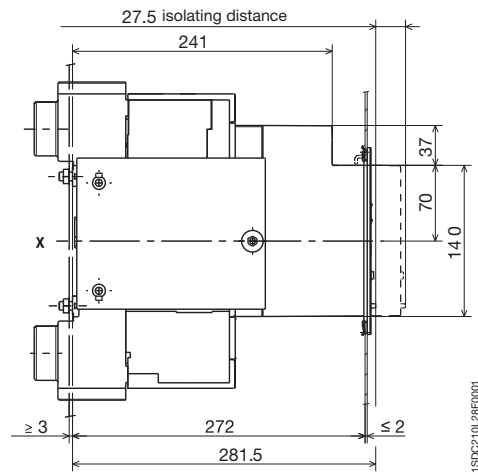

1SDC210L29FR001

1SDC210L29FR001

Flange for the compartment door (supplied as standard)

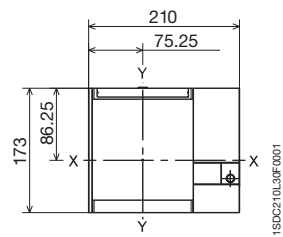

1SDC210L31FR001

Drilling templates for the compartment door and fitting flange

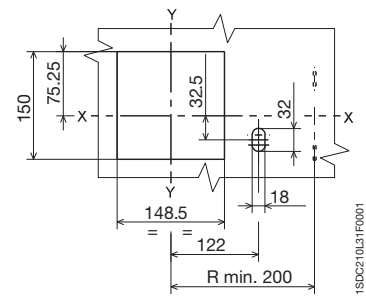

1SDC210L31FR001

Overall dimensions

Accessories for Tmax T6

Caption

- ① Padlock device for open position (maximum 3 padlocks to be provided by the user)
- ② Lock for compartment door
- ③ Dimension with AUE connector (early making contact)
- ④ Interlock mechanism
- ⑤ Frame
- ⑥ Drilling template for each version of terminals

Rotary handle operating mechanism on the circuit-breakers

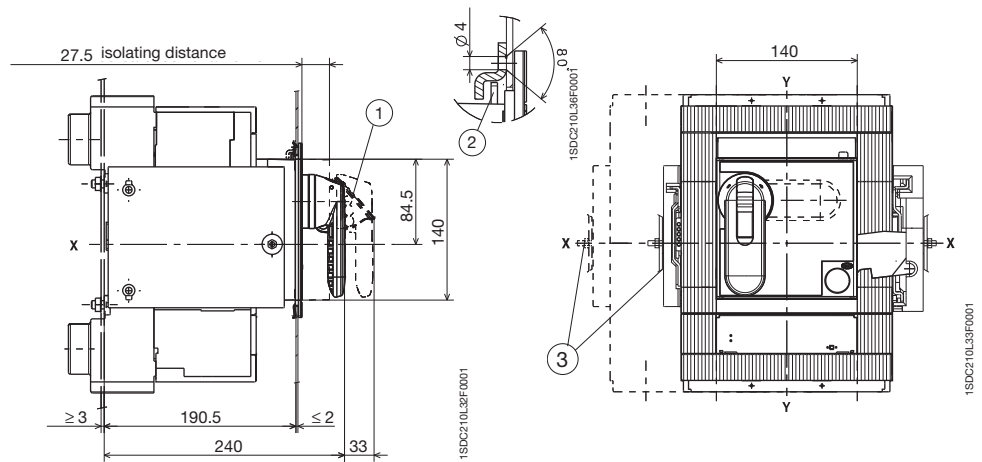

Flange for the compartment door

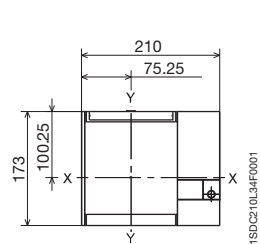

Drilling template for compartment door and fitting flange

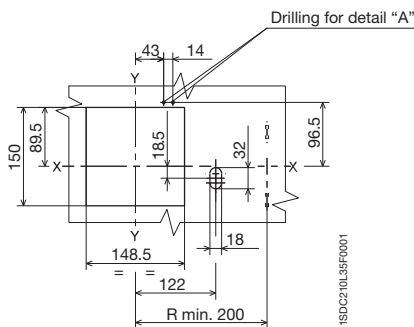

Mechanical interlock

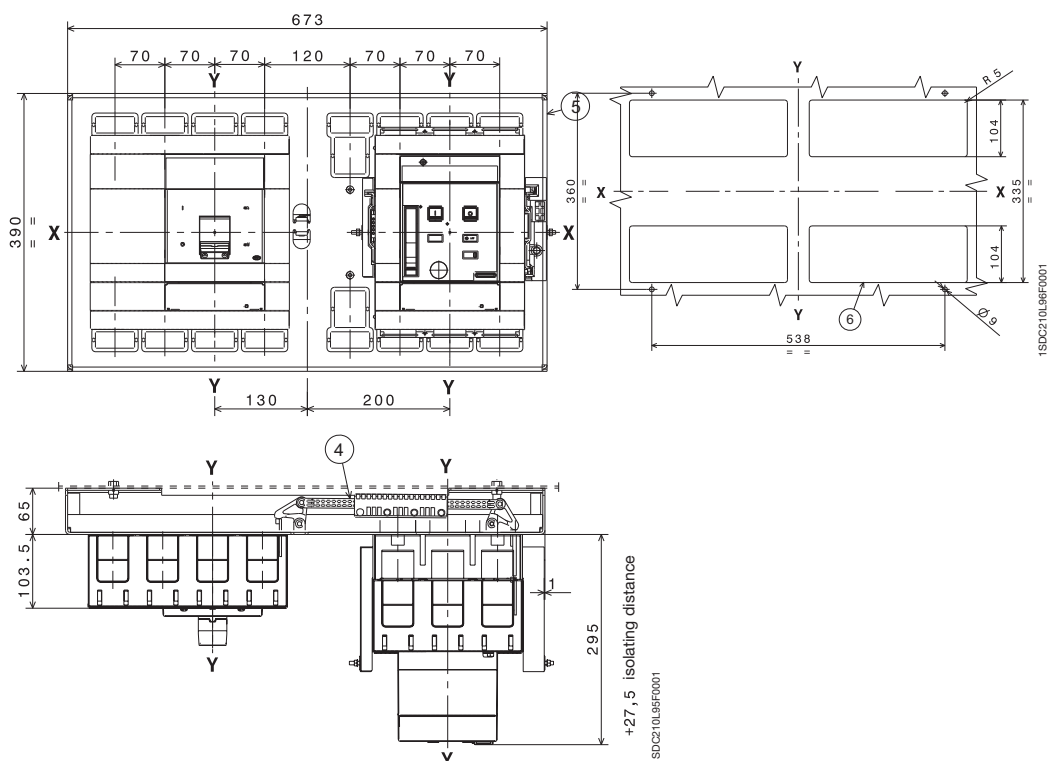

Overall dimensions

Accessories for Tmax T7

Fixed circuit-breaker Rotary handle operating mechanism on the circuit-breaker

Caption

- ① Rotary handle operating mechanism for circuit-breaker
- ② Compartment door interlock
- ③ Flange for the compartment door
- ④ Flange fixing screws
- ⑥ Support sheet drilling template
- ⑦ Key lock (optional)
- ⑧ Tightening torque: 2.5 Nm
- ⑨ Compartment door with flange sheet drilling
- ⑩ Compartment door sheet drilling for front 206 x 204
- ⑪ Terminal for auxiliary contacts
- ⑫ Reduced flange of the rotary handle for the compartment door (optional)
- ⑬ Compartment door sheet drilling for rotary handle
- ⑭ Compartment door sheet drilling without the rotary handle flange

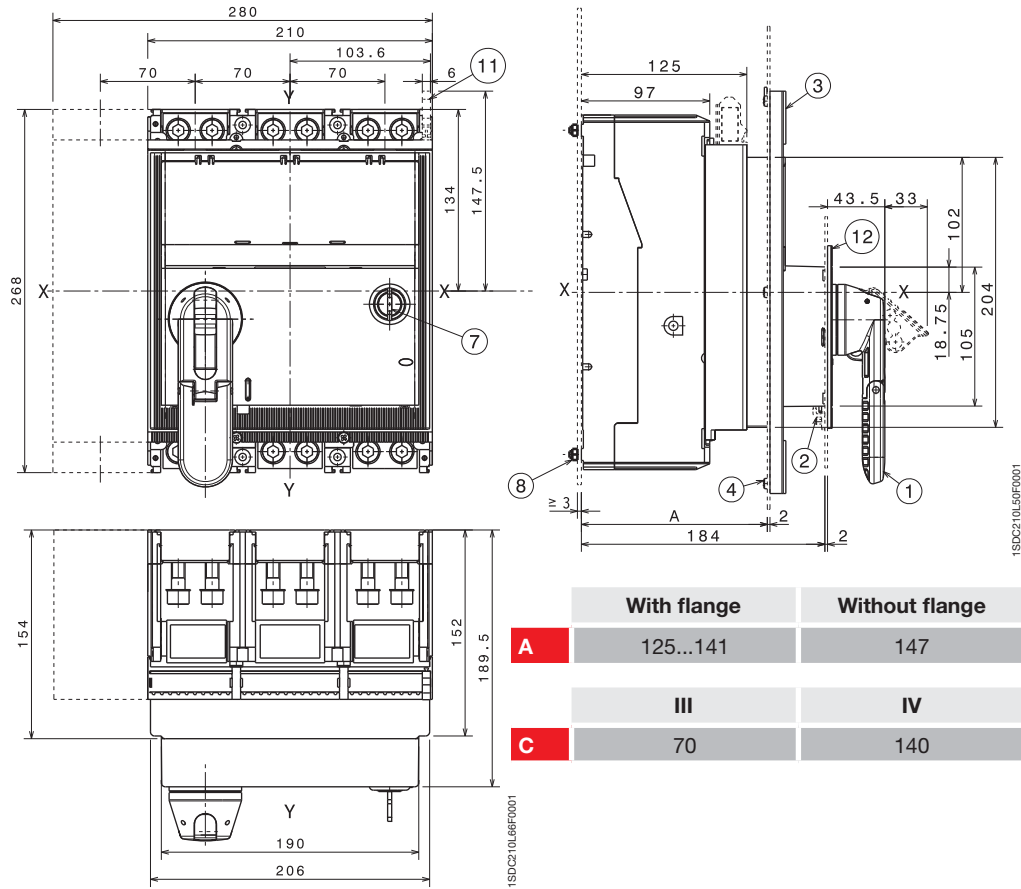

Flange for the compartment door (supplied as standard)

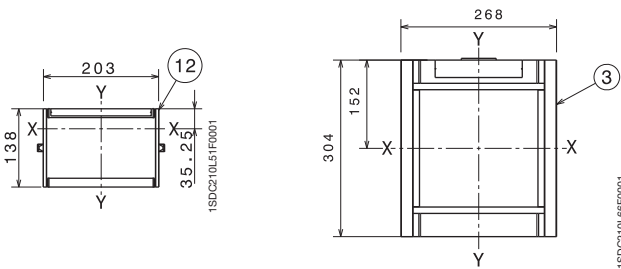

Drilling templates for support sheet

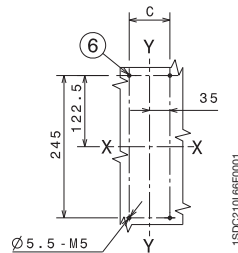

Drilling templates of the compartment door

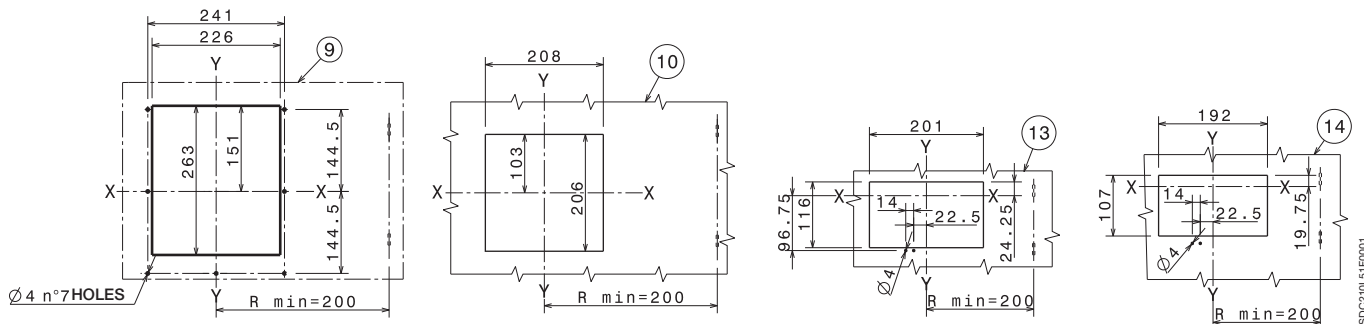

Overall dimensions

Accessories for Tmax T7

Rotary handle operating mechanism on the compartment door

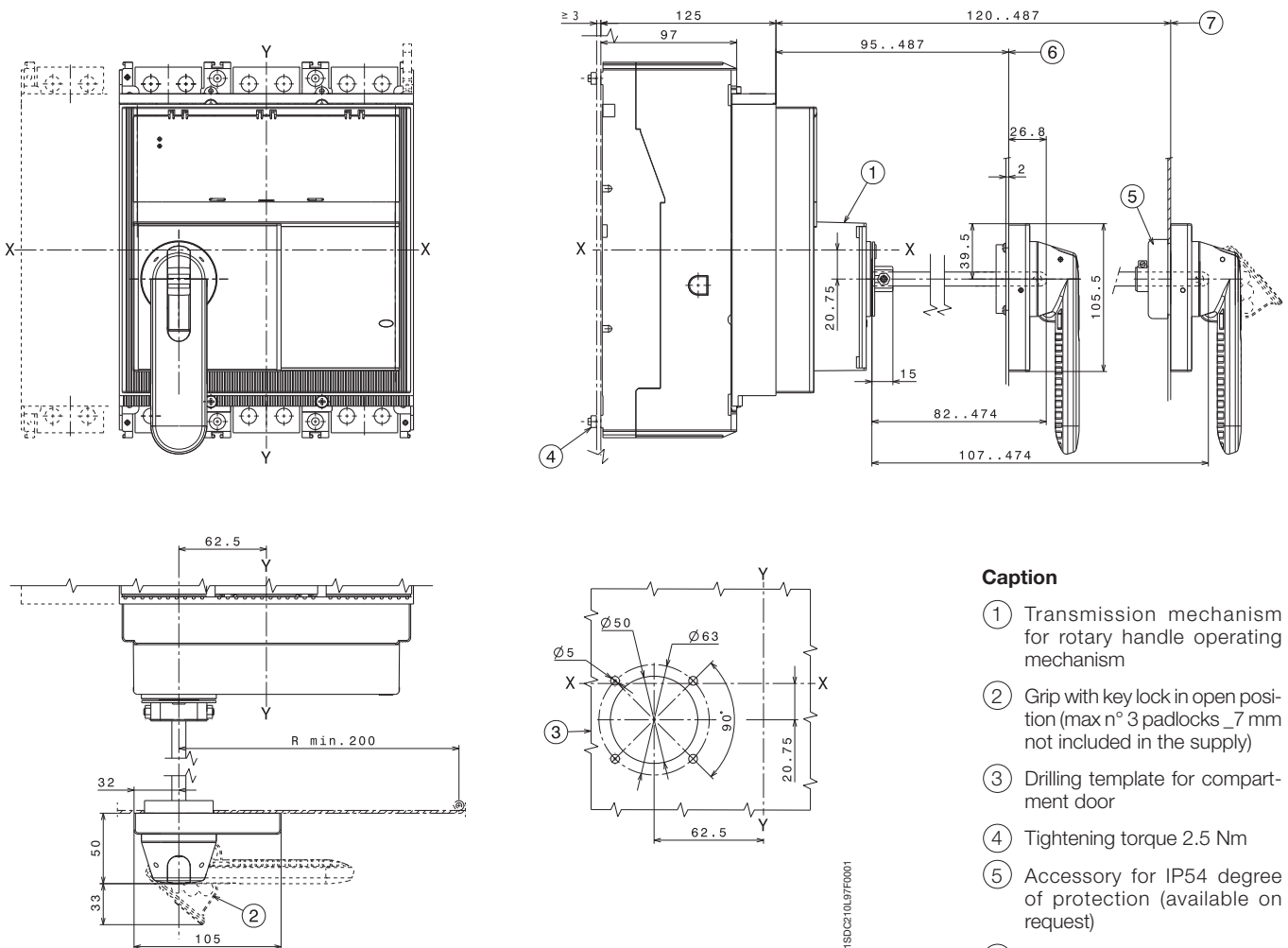

Caption

- ① Transmission mechanism for rotary handle operating mechanism
- ② Grip with key lock in open position (max n° 3 padlocks _7 mm not included in the supply)
- ③ Drilling template for compartment door
- ④ Tightening torque 2.5 Nm
- ⑤ Accessory for IP54 degree of protection (available on request)
- ⑥ Min...max distance from the front of the door
- ⑦ Min...max distance from the front of the door (with accessory with IP54 degree of protection)

1SDC210197F001

Overall dimensions

Accessories for Tmax T7

Caption

- ③ Mechanical vertical interlock for fixed circuit-breakers
- ④ Mechanical horizontal interlock for fixed circuit-breakers
- ⑤ Sheet drilling for wire passage of the mechanical interlock

Mechanical interlock for fixed circuit-breakers

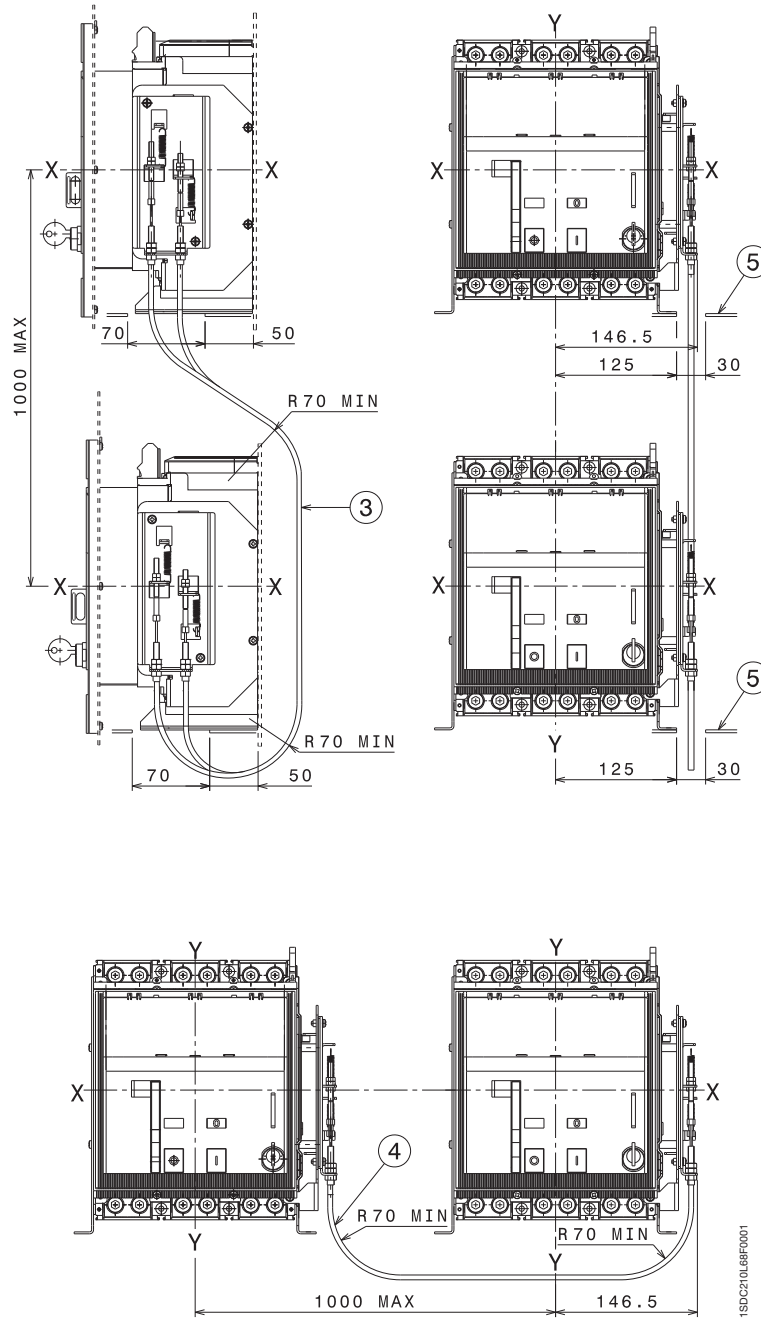

1SDC21015D0205

Caption

- ① Mechanical vertical interlock for withdrawable circuit-breakers
- ② Mechanical horizontal interlock for withdrawable circuit-breakers
- ⑤ Sheet drilling for wire passage of the mechanical interlock

Mechanical interlock for withdrawable circuit-breakers

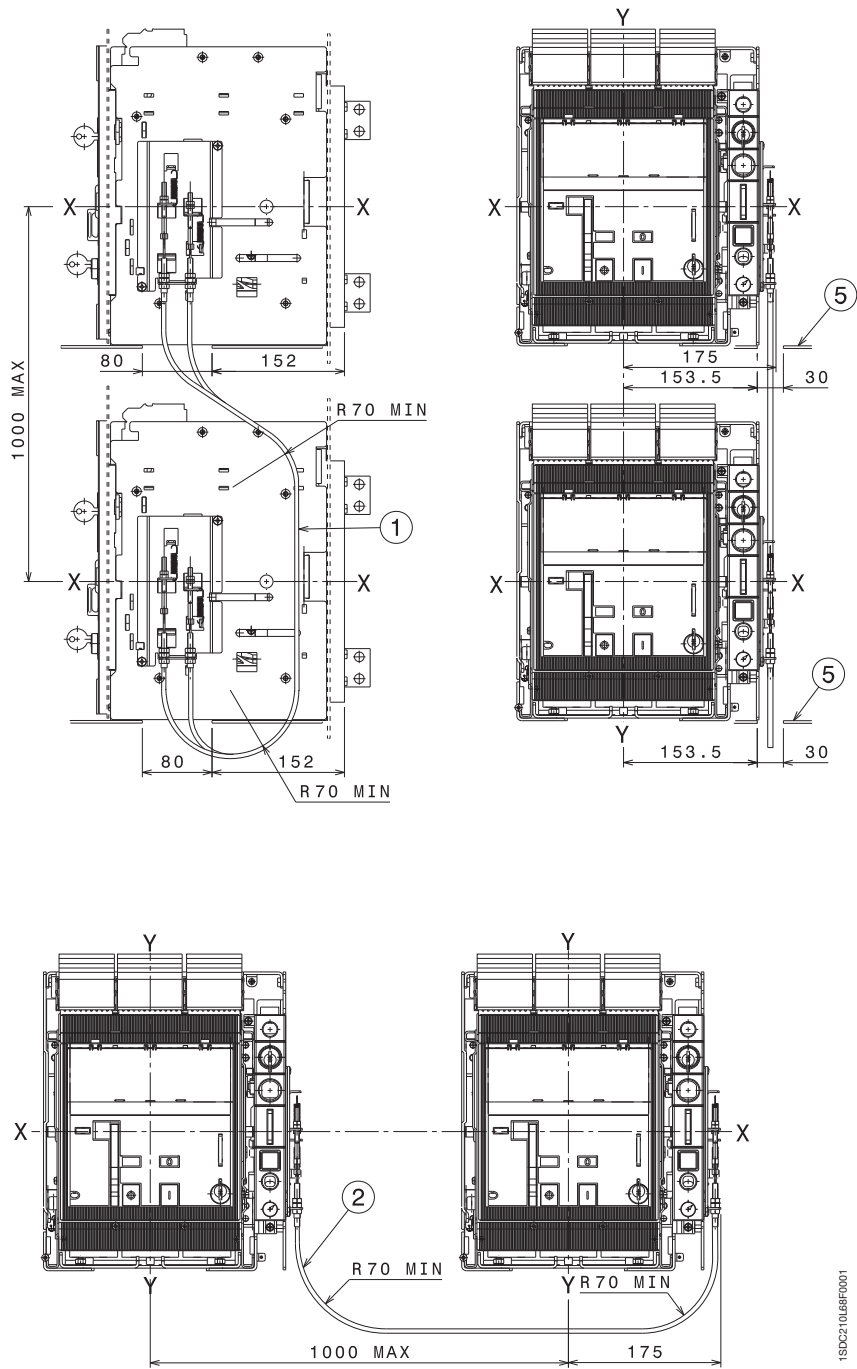

1SDC210LBRF0001

Overall dimensions

Distances to be respected

Insulation distances for installation in metallic cubicle

	A (mm)	B (mm)	C (mm)
T1	25	20	20
T2	25	20	20
T3	50	25	20
T4	30 ^(*)	25	25 ^(**)
T5	30 ^(**)	25	25 ^(**)
T6	35 ^(*)	25	20
T7	50 ^(*)	20	10

^(*) For $U_b \geq 440$ V and T6L all versions: distances A \Rightarrow 100 mm

^(**) For $U_n \geq 440$ V and ≤ 690 V: A = 60 mm, C = 45 mm and ≤ 690 V

Note: For the insulation distances of the 1000 V circuit-breakers, please ask ABB SACE.

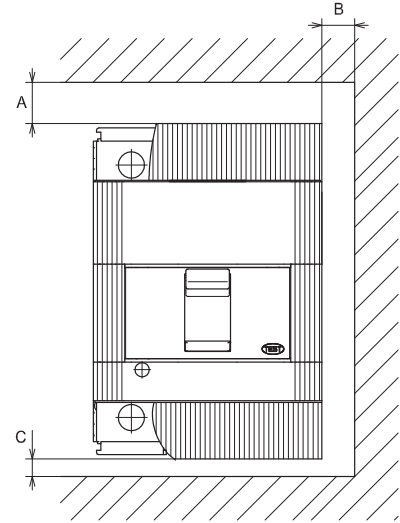

Minimum centre distance between two circuit-breakers side by side or superimposed

For assembly side by side or superimposed, check that the connection busbars or cables do not reduce the air insulation distance

Minimum centre distance for two circuit-breakers side by side

	Circuit-breaker width (mm)		Centre distance I (mm)	
	3 poles	4 poles	3 poles	4 poles
T1	76	102	76	102
T2	90	120	90	120
T3	105	140	105	140
T4	105	140	105 ^(*)	140 ^(*)
T5	140	186	140 ^(*)	186 ^(*)
T6	210	280	210	280
T7	210	280	210	280

^(*)T4 \rightarrow For $U_b: \geq 500$ V and ≤ 690 V minimum centre I (mm) 3 poles 145, minimum centre I (mm) 4 poles 184

T5 \rightarrow For $U_b: \geq 500$ V and ≤ 690 V minimum centre I (mm) 3 poles 180, minimum centre I (mm) 4 poles 224

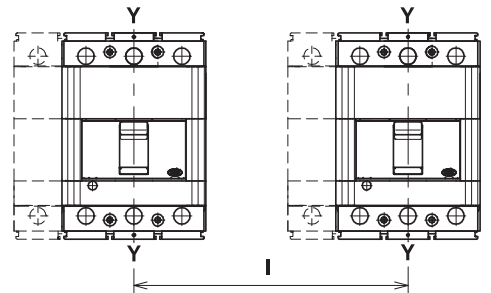

Minimum centre distance for superimposed circuit-breakers

	H (mm)
T1	60
T2	90
T3	140
T4	160
T5	160
T6	180
T7	180

Caption

- ① Connection - not insulated
- ② Insulated cable
- ③ Cable terminal

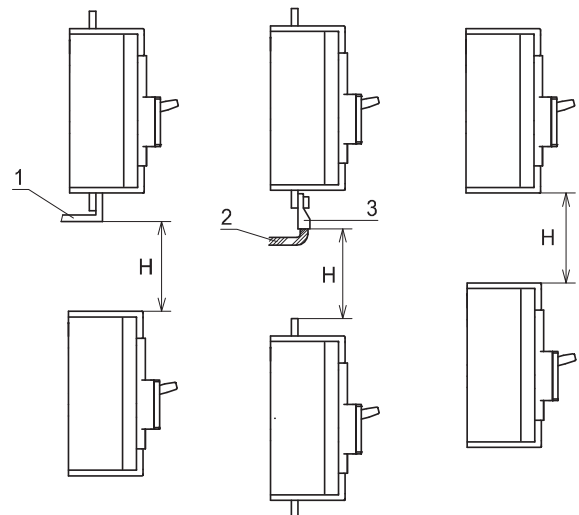

Note: The dimensions shown apply for operating voltage U_b up to 690 V. The dimensions to be respected must be added to the maximum dimensions of the various different versions of the circuit-breakers, including the terminals. For 1000 V versions, please ask ABB SACE.





Index

General information	7/2
Instructions for ordering	7/3
Power distribution circuit-breakers.....	7/7
Circuit-breakers for zone selectivity.....	7/22
Motor protection circuit-breakers.....	7/24
Circuit-breakers for use up to 1150 V AC and 1000 V DC	7/28
Switch disconnectors	7/33
Breaking units.....	7/36
Trip units.....	7/38
Fixed parts, conversion kit and accessories for fixed parts.....	7/41
Accessories.....	7/45

Ordering codes

General information

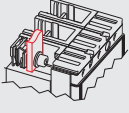
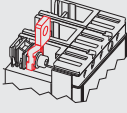
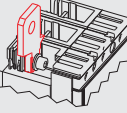
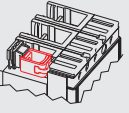
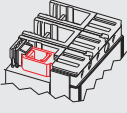
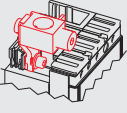
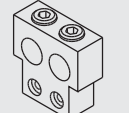
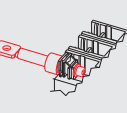
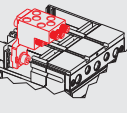
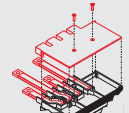
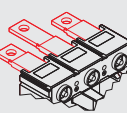
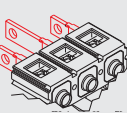
Abbreviations used to describe the apparatus

	F = Front terminals		EF = Front extended terminals		ES = Front extended spread terminals
	FC Cu = Front terminals for copper cables		FC CuAl = Front terminals for Cu/Al cables		FC CuAl = Front terminals for Cu/Al cables (housed externally)
	RC CuAl = Rear terminals for Cu/Al cables		R = Rear terminals		MC = Multi-cable terminals
	HR for RC221/222 = Rear flat horizontal terminals		HR = Rear flat horizontal terminals		VR = Rear flat vertical terminals
HR/VR = Rear flat terminals		RS = Rear spread terminals			
	I₃ = Magnetic trip current [A]	I_u	Rated uninterrupted current of the circuit-breaker [A]	N = 50%	Protection of the neutral at 50% or at 100% of that of the phases [A]
	I_n = Rated current of the thermomagnetic trip unit [A]	I_{cu}	Rated ultimate short-circuit breaking capacity [A]	N = 100%	
		I_{cw}	Rated short-time withstand current for 1s		
TMF	= Thermomagnetic trip unit with fixed thermal and magnetic threshold	TMA	= Thermomagnetic trip unit with adjustable thermal and magnetic threshold	MF	= Fixed magnetic only trip units
TMD	= Thermomagnetic trip unit with adjustable thermal and fixed magnetic threshold	TMG	= Thermomagnetic trip unit for generator protection	MA	= Adjustable magnetic only trip units
				PR22_	= Electronic trip units
				PR23_	= Electronic trip units
				PR33_	= Electronic trip units

Ordering codes

Instructions for ordering

Ordering Tmax circuit-breakers fitted with the accessories indicated in the catalogue means that these must be indicated by means of the relative sales codes expressly associated with the circuit-breaker code. The following examples are of particular importance for correctly loading orders for Tmax circuit-breakers fitted with accessories.

1) Terminal Kit for fixed circuit-breaker

To fit the circuit-breaker with different terminal accessories than those supplied on the basic circuit-breaker, it is possible to ask for complete kits (6 or 8 pieces) or half kits (3 or 4 pieces). For conversion of a complete circuit-breaker, it is necessary to specify the complete terminal kit. In the case of a mixed solution, the first code specified indicates the terminals to be mounted at the top, the second indicates the terminals to be mounted at the bottom. On the other hand, when only 3 or 4 pieces are requested, it is important to specify expressly whether the half kit is to be mounted at the top (*) rather than at the bottom (**).

a) Tmax T3N 250 with top FC Cu and bottom F terminals

	1SDA...R1
T3N 250 TMD 63 3p F F	051241
1/2 KIT FC Cu T3 3p ^(*)	051482

c) Tmax T3N 250 with top F and bottom FC Cu terminals

	1SDA...R1
T3N 250 TMD 63 3p F F	051241
1/2 KIT FC Cu T3 3p ^(**)	051482

d) Tmax T3N 250 with FC Cu top and bottom terminals

	1SDA...R1
T3N 250 TMD 63 3p F F	051241
1 KIT FC Cu T3 3p	051480

e) Tmax T3N 250 with top ES and FC Cu bottom terminals

	1SDA...R1
T3N 250 TMD 63 3p F F	051241
1/2 KIT ES T3 3p ^(*)	051494
1/2 KIT FC Cu T3 3p ^(**)	051482

2) T2-T3 electrical accessories on moving part of plug-in circuit-breaker

Fitting the moving parts of plug-in T2-T3 circuit-breakers with SOR, UVR and AUX and with SOR-C, UVR-C and AUX-C accessories always requires the appropriate plug-socket indicated in the catalogue.

a) Tmax T2N 160 moving part of plug-in circuit-breakers with auxiliary contacts

	1SDA...R1
T2N 160 F F PR221DS-LS 10 4p	051128
Kit P MP T2 4p	051412
AUX-C 2Q 1SY	055504
socket-plug connectors 6 pole	051363

b) Tmax T2N 160 moving part of plug-in circuit-breakers with auxiliary contacts and opening coil

	1SDA...R1
T2N 160 F F TMD 10 4p	050970
Kit P MP T2 4p	051412
AUX 3Q 1SY 250 V AC/DC	051369
SOR 220...240 V AC / 220...250 V DC	051336
socket-plug connectors 6 pole	051363
socket-plug connectors 3 pole	051364

Ordering codes

Instructions for ordering

3) T4-T5 electrical accessories on moving part of plug-in circuit-breaker

Fitting the moving parts of plug-in T4-T5 circuit-breakers with SOR, UVR and AUX accessories always requires the appropriate plug-sockets, i.e. in the case of cabled electrical accessories SOR-C, UVR-C, AUX-C, MOE, MOE-E and AUE, the ADP adapters indicated in the catalogue.

a) Tmax T4H 250 moving part of plug-in circuit-breakers with auxiliary contacts

	1SDA...R1
T4L 250 F F P221DS-LS/I 100 4p	054081
Kit P MP T4 4p	054840
AUX 3Q 1SY 250 V AC/DC	051369
socket-plug connectors 12 pole	051362

b) Tmax T4H 250 moving part of plug-in circuit-breakers with cabled auxiliary contacts

	1SDA...R1
T4L 250 F F P221DS-LS/I 100 4p	054081
Kit P MP T4 4p	054840
AUX-C 3Q 1SY 250 V AC/DC	054911
ADP – 12 pin adapter	054923

c) Tmax T5H 630 moving part of plug-in circuit-breaker with SOR-C, MOE and AUX-C

	1SDA...R1
T4L 250 F F P221DS-LS/I 100 4p	054081
Kit P MP T4 4p	054840
SOR-C 220...240 V AC – 220...250V DC	054873
MOE T4-T5 220...250 V AC/DC	054897
ADP – 10 pin adapter	054924
AU-C 1Q 1SY 250 V AC/DC	054910
ADP – 6 pin adapter	054922

4) T4-T5 electrical accessories on moving part of withdrawable circuit-breaker

Fitting the moving parts of T4-T5 withdrawable circuit-breakers can only take place using electrical accessories in the cabled version, i.e. SOR-C, UVR-C, AUX-C, MOE, MOE-E and AUE with ADP adapter.

a) Tmax T5V 630 moving part of withdrawable circuit-breaker with UVR-C and MOE

	1SDA...R1
T5V 630 F F TMA 500 4p N=100%	054495
Kit W MP T5 630 4p	054850
UVR-C 24...30 V AC/DC	054887
MOE T4-T5 24 V DC	054894
ADP – 10 pin adapter	054924

b) Tmax T4S 250 moving part of withdrawable circuit-breaker SOR-C, RHE and AUE

	1SDA...R1
T4S 250 PR221DS-LS/I 100 4p F F	054033
KIT W MP T4 4p	054842
RHE normal for withdrawable circuit-breaker	054933
AUE – 2 early contacts	054925
SOR-C 220...240 V AC / 220...250 V DC	054873
ADP – 10 pin adapter	054924

5) Rear mechanical interlock T3

The rear MIR interlock for T3 allows all the accessories to be used. To be able to take the circuit-breakers and/or the fixed parts mounted directly on the interlocking plate, it is necessary to use code 1SDA050093R1 to be specified regarding the second circuit-breaker (or fixed part) to be interlocked.

Horizontal mechanical interlock made between two T3S 250

		1SDA...R1
POS1	T3S 250 TMD 200 4p FF	051305
	MIR-H rear mechanical interlock for T3	063324
POS2	T3S 250 TMD 160 4p FF	051304
	Extra code for circuit-breaker/fixed part mounted on the interlock	050093

6) T4-T5 mechanical interlock

The rear interlock for T4 and T5, consisting of the MIR-HB or MIR-VB frame unit and the MIR-P plates, allows use of all the front accessories compatible with the circuit-breakers used. To be able to receive the circuit-breakers mounted directly on the interlock plate, code 1SDA050093R1 must be specified regarding the second circuit-breaker (or fixed part) which is to be interlocked.

Horizontal mechanical interlock made between T4H 320 and T5L 630

		1SDA...R1
POS1	T4H 320 PR221DS-LS/I 320 4p F F	054137
	MIR-HB horizontal interlock frame unit	054946
	MIR-P plates for type C interlock	054950
POS2	T5L 630 PR221DS-LS/I 630 4p F F	054424
	Code for circuit-breakers mounted on the plate	050093

7) PR222DS/PD T4-T5

The T4 and T5 circuit-breakers can be fitted with the PR222DS/PD electronic trip unit, with communication and integrated control functions, using the special extracodes indicated in the catalogue. The circuit-breakers fitted with the PR222DS/PD trip unit can only have the AUX-E electronic version of auxiliary contacts mounted, to communicate the state of the circuit-breaker to the PR222DS/PD, and the MOE-E dedicated stored energy operating mechanism, to remotely control circuit-breaker opening and closing.

a) T4V 250 with dialogue, auxiliary contacts and motor operator

	1SDA...R1
T4V 250 PR222DS/PD-LSIG 250 3p F F	054104
Extracode - Dialogue unit for LSIG	055067
AUX-E-C 1Q 1SY	054916
MOE-E T4-T5 380 V AC	054903
X3 for PR222DS/P/PD T4-T5 F	055059

b) T4V 250 moving part of withdrawable circuit-breaker with dialogue, auxiliary contacts and motor operator

	1SDA...R1
T4V 250 PR222DS/PD-LSIG 250 3p F F	054104
Extracode - Dialogue unit for LSIG	055067
Kit W MP T4	054841
AUX-E-C 1Q 1SY	054916
ADP - 6 pin adapter	054922
MOE-E T4-T5 380 V AC	054903
ADP - 10 pin adapter	054924
X3 for PR222DS/P/PD T4-T5 P/W	055061

Ordering codes

Instructions for ordering

8) Rating plug for Tmax T7

Thanks to the extra codes for the Tmax T7 rating plug (see page 3/42), it is possible to ask for a Tmax T7 circuit-breaker with lower rated current than the standard versions.

T7S 400 with PR332/P LSI – lever operating mechanism

	1SDA...R1
T7S 800 PR332/P-LSIG In=800 3p F F	061968
Extra code for 400 A rating plug	063153

9) Sliding contacts for Tmax T7 in version withdrawable

The electrical accessories of Tmax T7 in the withdrawable version must be fitted with suitable sliding contacts for the moving part and for the fixed part, as per table on page 3/4.

(a) T7S 1000 PR231/P with lever operating mechanism in withdrawable version, opening coil and auxiliary contacts

	1SDA...R1	
POS1	T7S 1000 PR231/P LSI In=1000A 3p F F	062738
	Kit MP T7-T7M W 3p	062162
	SOR 240...250 V AC/DC Opening coil	062070
	AUX 1Q + 1SY Auxiliary contacts	062104
	Right PM sliding block	062166
POS2	Fixed part for withdrawable T7	062045
	Right PF sliding block	062169

(b) T7S 1250 PR332/P with lever operating mechanism in withdrawable version and undervoltage release

	1SDA...R1	
POS1	T7S 1250 PR332/P LSI In=1250A 3p F F	062871
	Kit MP T7-T7M W 3p	062162
	UVR 240...250 V AC/DC Undervoltage release	062092
	Right PM sliding block	062166
	Central PM sliding block	062165
POS2	Fixed part for withdrawable T7	062045
	Right PF sliding block	062169
	Central PF sliding block	062168

10) Interchangeability of the PR231/P trip unit for Tmax T7

Interchangeable T7S 800 PR231/P, with lever operating mechanism

	1SDA...R1
T7S 800 PR231/P LSI In=800 A 4p F F	061973
Extra code for PR231/P interchangeability	063140

11) Motorisation for Tmax T7

For Tmax T7 motorisation, the circuit-breaker in T7M version which can be motorised, must be fitted with spring charging geared motor, opening coil and closing coil.

Motorised T7S 1000 PR232/P

	1SDA...R1
T7S 1000 M PR232/P LSI In=1000 A 4p F F	062763
220...250 V AC/DC Spring charging geared motor	062116
SOR 240...250 V AC/DC Opening coil	062070
SCR 240...250 V AC/DC Closing coil	062081

Ordering codes

Power distribution circuit-breakers



1SDC21 01B0F0004



1SDC21 0302F0004

T1 1p 160 – Fixed (F) – 1 Pole - Front terminals for copper cables (FC Cu)

		In	I ₃	1SDA.....R1			
				B			
<i>Thermomagnetic trip unit with fixed thresholds - TMF</i>		<i>Icu (230 V)</i>		25 kA ⁽¹⁾			
	16	630		052616			
	20	630		052617			
	25	630		052618			
	32	630		052619			
	40	630		052620			
	50	630		052621			
	63	630		052622			
	80	800		052623			
	100	1000		052624			
	125	1250		052625			
	160	1600		052626			

⁽¹⁾ In = 16 A, In = 20 A → I_{cw} @ 230 V = 16 kA

T1 160 – Fixed (F) – 3 Poles - Front terminals for copper cables (FC Cu)

		In	I ₃	1SDA.....R1		
				B	C	N
<i>Thermomagnetic trip unit - TMD</i>		<i>Icu (415 V)</i>		16 kA	25 kA	36 kA
	16	500		063514		
		630		050870		
	20	500		063515		
		630		050871		
	25	500		063516	063526	
		630		050872	050894	
	32	500		063517	063527	050917
		630		050873	050895	
	40	500		063518	063528	050918
		630		050874	050896	
	50	500		063519	063529	050919
		630		050875	050897	
	63	630		050876	050898	050920
	80	800		050877	050899	050921
	100	1000		050878	050900	050922
	125	1250		050879	050901	050923
	160	1600		050880	050902	050924

T1 160 – Fixed (F) – 4 Poles - Front terminals for copper cables (FC Cu)

		In	I ₃	1SDA.....R1		
				B	C	N
<i>Thermomagnetic trip unit - TMD</i>		<i>Icu (415 V)</i>		16 kA	25 kA	36 kA
	16	500		063520		
		630		050881		
	20	500		063521		
		630		050882		
	25	500		063522	063530	
		630		050883	050905	
	32	500		063523	063531	050928
		630		050884	050906	
	40	500		063524	063532	050929
		630		050885	050907	
	50	500		063525	063533	050930
		630		050886	050908	
	63	630		050887	050909	050931
	80	800		050888	050910	050932
	100	1000		050889	050911	050933
	125	1250		050890	050912	050934
N=50%	160	1600		050891	050913	050935
N=100%	160	1600		050936	050937	050938

Ordering codes

Power distribution circuit-breakers

1SDC210309R0004



T2 160 – Fixed (F) – 3 Poles - Front terminals (F)

		In	I ₃	1SDA.....R1			
				N	S	H	L
Thermomagnetic trip unit - TMD		Icu (415 V)		36 kA	50 kA	70 kA	85 kA
	1.6	16		050940	050984	051028	051072
	2	20		050941	050985	051029	051073
	2.5	25		050942	050986	051030	051074
	3.2	32		050943	050987	051031	051075
	4	40		050944	050988	051032	051076
	5	50		050945	050989	051033	051077
	6.3	63		050946	050990	051034	051078
	8	80		050947	050991	051035	051079
	10	100		050948	050992	051036	051080
	12.5	125		050949	050993	051037	051081
	16	500		050950	050994	051038	051082
	20	500		050951	050995	051039	051083
	25	500		050952	050996	051040	051084
	32	500		050953	050997	051041	051085
	40	500		050954	050998	051042	051086
	50	500		050955	050999	051043	051087
	63	630		050956	051000	051044	051088
	80	800		050957	051001	051045	051089
	100	1000		050958	051002	051046	051090
	125	1250		050959	051003	051047	051091
	160	1600		050960	051004	051048	051092

		In	I ₃	1SDA.....R1			
				N	S		
Thermomagnetic trip unit for generator protection - TMG⁽¹⁾		Icu (415 V)		36 kA	50 kA		
	25	160		061867	061883		
	40	200		061868	061884		
	63	200		061869	061885		
	80	240		061870	061886		
	100	300		061871	061887		
	125	375		061872	061888		
	160	480		061873	061889		

		In	1SDA.....R1			
			N	S	H	L
Electronic trip unit		Icu (415 V)	36 kA	50 kA	70 kA	85 kA
PR221DS-LS/I	10		051123	051133	051143	051153
PR221DS-LS/I	25		051124	051134	051144	051154
PR221DS-LS/I	63		051125	051135	051145	051155
PR221DS-LS/I	100		051126	051136	051146	051156
PR221DS-LS/I	160		051127	051137	051147	051157
PR221DS-I	10		051163	051174	051184	051194
PR221DS-I	25		051164	051175	051185	051195
PR221DS-I	63		051165	051176	051186	051196
PR221DS-I	100		051166	051177	051187	051197
PR221DS-I	160		051168	051178	051188	051198
PR221GP	63		065352	065358		
PR221GP	100		065353	065359		
PR221GP	160		065354	065360		

Note:

The trip coil of the T2 circuit-breaker with PR221DS electronic trip unit is housed in the right slot.

For T2 with PR221DS the following groups of auxiliary contacts are available:

- 1SDA053704R1 Aux-C 1S51-1Q-1SY
- 1SDA055504R1 Aux-C 2Q-1SY

⁽¹⁾ For availability, please ask ABB SACE

see "Abbreviation caption" page 7/2

1SDC21030R0004



T2 160 – Fixed (F) – 4 Poles – Front terminals (F)

		In	I₃	1SDA R1			
				N	S	H	L
				36 kA	50 kA	70 kA	85 kA
				Icu (415 V)			
Thermomagnetic trip unit - TMD							
	1.6	16		050962	051006	051050	051094
	2	20		050963	051007	051051	051095
	2.5	25		050964	051008	051052	051096
	3.2	32		050965	051009	051053	051097
	4	40		050966	051010	051054	051098
	5	50		050967	051011	051055	051099
	6.3	63		050968	051012	051056	051100
	8	80		050969	051013	051057	051101
	10	100		050970	051014	051058	051102
	12.5	125		050971	051015	051059	051103
	16	500		050972	051016	051060	051104
	20	500		050973	051017	051061	051105
	25	500		050974	051018	051062	051106
	32	500		050975	051019	051063	051107
	40	500		050976	051020	051064	051108
	50	500		050977	051021	051065	051109
	63	630		050978	051022	051066	051110
	80	800		050979	051023	051067	051111
	100	1000		050980	051024	051068	051112
N=50%	125	1250		050981	051025	051069	051113
N=50%	160	1600		050982	051026	051070	051114
N=100%	125	1250		051115	051117	051119	051121
N=100%	160	1600		051116	051118	051120	051122

		In	I₃	1SDA R1			
				N	S		
				36 kA	50 kA		
				Icu (415 V)			
Thermomagnetic trip unit for generator protection - TMG⁽¹⁾							
	25	160		061875	061891		
	40	200		061876	061892		
	63	200		061877	061893		
	80	240		061878	061894		
	100	300		061879	061895		
	125	375		061880	061896		
	160	480		061881	061897		

		In	1SDA R1				
				N	S	H	L
				36 kA	50 kA	70 kA	85 kA
				Icu (415 V)			
Electronic trip unit							
PR221DS-LS/I	10			051128	051138	051148	051158
PR221DS-LS/I	25			051129	051139	051149	051159
PR221DS-LS/I	63			051130	051140	051150	051160
PR221DS-LS/I	100			051131	051141	051151	051161
PR221DS-LS/I	160	N=50%		051132	051142	051152	051162
PR221DS-LS/I	160	N=100%		051613	051614	051615	051616
PR221DS-I	10			051169	051179	051189	051199
PR221DS-I	25			051170	051180	051190	051200
PR221DS-I	63			051171	051181	051191	051201
PR221DS-I	100			051172	051182	051192	051202
PR221DS-I	160	N=50%		051173	051183	051193	051203
PR221DS-I	160	N=100%		051617	051618	051619	051620
PR221GP	63			065355	065361		
PR221GP	100			065356	065362		
PR221GP	160			065357	065363		

Note:
 The trip coil of the T2 circuit-breaker with PR221DS electronic trip unit is housed in the right slot.
 For T2 with PR221DS the following groups of auxiliary contacts are available:
 – 1SDA053704R1 Aux-C 1S51-1Q-1SY
 – 1SDA055504R1 Aux-C 2Q-1SY

⁽¹⁾ For availability, please ask ABB SACE

see "Abbreviation caption" page 7/2

Ordering codes

Power distribution circuit-breakers

1SDC210304F0004



T3 250 – Fixed (F) – 3 Poles - Front terminals (F)

		In	I ₃			1SDA.....R1					
				N	S						
				36 kA	50 kA						
Thermomagnetic trip unit - TMD		Icu (415 V)									
	63	630		051241	051263						
	80	800		051242	051264						
	100	1000		051243	051265						
	125	1250		051244	051266						
	160	1600		051245	051267						
	200	2000		051246	051268						
	250	2500		051247	051269						

		In	I ₃			1SDA.....R1					
				N	S						
				36 kA	50 kA						
Thermomagnetic trip unit for generator protection - TMG		Icu (415 V)									
	63	400		055105	055119						
	80	400		055106	055120						
	100	400		055107	055121						
	125	400		055108	055122						
	160	480		055109	055123						
	200	600		055110	055124						
	250	750		055111	055125						

T3 250 – Fixed (F) – 4 Poles - Front terminals (F)

		In	I ₃			1SDA.....R1					
				N	S						
				36 kA	50 kA						
Thermomagnetic trip unit - TMD		Icu (415 V)									
	63	630		051252	051274						
	80	800		051253	051275						
	100	1000		051254	051276						
N=50%	125	1250		051255	051277						
N=50%	160	1600		051256	051278						
N=50%	200	2000		051257	051279						
N=50%	250	2500		051258	051280						
N=100%	125	1250		051303	051307						
N=100%	160	1600		051304	051308						
N=100%	200	2000		051305	051309						
N=100%	250	2500		051306	051310						

		In	I ₃			1SDA.....R1					
				N	S						
				36 kA	50 kA						
Thermomagnetic trip unit for generator protection - TMG		Icu (415 V)									
	63	400		055112	055126						
	80	400		055113	055127						
	100	400		055114	055128						
	125	400		055115	055129						
	160	480		055116	055130						
	200	600		055117	055131						
	250	750		055118	055132						

see "Abbreviation caption" page 7/2

1SDC210309F0004



T4 250 – Fixed (F) – 3 Poles - Front terminals (F)

		In	I ₃	1SDA.....R1				
				N	S	H	L	V
Thermomagnetic trip unit - TMD and TMA		Icu (415 V)		36 kA	50 kA	70 kA	120 kA	200 kA
	20	320		054171	054189	054207	054225	054243
	32	320		054172	054190	054208	054226	054244
	50	500		054173	054191	054209	054227	054245
	80	400...800		054174	054192	054210	054228	054246
	100	500...1000		054175	054193	054211	054229	054247
	125	625...1250		054176	054194	054212	054230	054248
	160	800...1600		054177	054195	054213	054231	054249
	200	1000...2000		054178	054196	054214	054232	054250
	250	1250...2500		054179	054197	054215	054233	054251

		In	1SDA.....R1				
			N	S	H	L	V
Electronic trip unit		Icu (415 V)	36 kA	50 kA	70 kA	120 kA	200 kA
PR221DS-LS/I	100		053997	054021	054045	054069	054093
PR221DS-LS/I	160		053998	054022	054046	054070	054094
PR221DS-LS/I	250		053999	054023	054047	054071	054095
PR221DS-I	100		054000	054024	054048	054072	054096
PR221DS-I	160		054001	054025	054049	054073	054097
PR221DS-I	250		054002	054026	054050	054074	054098
PR222DS/P-LSI	100		054003	054027	054051	054075	054099
PR222DS/P-LSI	160		054004	054028	054052	054076	054100
PR222DS/P-LSI	250		054005	054029	054053	054077	054101
PR222DS/P-LSIG	100		054006	054030	054054	054078	054102
PR222DS/P-LSIG	160		054007	054031	054055	054079	054103
PR222DS/P-LSIG	250		054008	054032	054056	054080	054104
PR223DS	160		059491	059499	059507	059515	059523
PR223DS	250		059493	059501	059509	059517	059525

Ordering codes

Power distribution circuit-breakers

T4 250 – Fixed (F) – 4 Poles - Front terminals (F)

1SDC210309F0004



			1SDA.....R1					
			N	S	H	L	V	
Thermomagnetic trip unit - TMD and TMA	In	I₃	Icu (415 V)	36 kA	50 kA	70 kA	120 kA	200 kA
				20	32	50	80	100
N=50%								
N=50%								
N=50%								
N=50%								
N=100%								
N=100%								
N=100%								
N=100%								

			1SDA.....R1					
			N	S	H	L	V	
Electronic trip unit	In		Icu (415 V)	36 kA	50 kA	70 kA	120 kA	200 kA
				100	160	250	100	160
PR221DS-LS/I								
PR221DS-LS/I								
PR221DS-LS/I								
PR221DS-I								
PR221DS-I								
PR221DS-I								
PR222DS/P-LSI								
PR222DS/P-LSI								
PR222DS/P-LSI								
PR222DS/P-LSIG								
PR222DS/P-LSIG								
PR222DS/P-LSIG								
PR223DS								
PR223DS								

1SDC210015D0205



T4 320 – Fixed (F) – 3 Poles - Front terminals (F)

		In	1SDA.....R1				
			N	S	H	L	V
Electronic trip unit		Icu (415 V)	36 kA	50 kA	70 kA	120 kA	200 kA
PR221DS-LS/I	320		054117	054125	054133	054141	054149
PR221DS-I	320		054118	054126	054134	054142	054150
PR222DS/P-LSI	320		054119	054127	054135	054143	054151
PR222DS/P-LSIG	320		054120	054128	054136	054144	054152
PR223DS	320		059495	059503	059511	059519	059527

T4 320 – Fixed (F) – 4 Poles - Front terminals (F)

		In	1SDA.....R1				
			N	S	H	L	V
Electronic trip unit		Icu (415 V)	36 kA	50 kA	70 kA	120 kA	200 kA
PR221DS-LS/I	320		054121	054129	054137	054145	054153
PR221DS-I	320		054122	054130	054138	054146	054154
PR222DS/P-LSI	320		054123	054131	054139	054147	054155
PR222DS/P-LSIG	320		054124	054132	054140	054148	054156
PR223DS	320		059496	059504	059512	059520	059528

Ordering codes

Power distribution circuit-breakers

1SDC21036F004



T5 400 – Fixed (F) – 3 Poles - Front terminals (F)

		In	I _s	1SDA.....R1				
				N	S	H	L	V
Thermomagnetic trip unit - TMA		Icu (415 V)	36 kA	50 kA	70 kA	120 kA	200 kA	
320 1600...3200			054436	054440	054444	054448	054452	
400 2000...4000		054437	054441	054445	054449	054453		

		In	1SDA.....R1				
			N	S	H	L	V
Electronic trip unit		Icu (415 V)	36 kA	50 kA	70 kA	120 kA	200 kA
PR221DS-LS/I	320		054316	054332	054348	054364	054380
PR221DS-LS/I	400	054317	054333	054349	054365	054381	
PR221DS-I	320	054318	054334	054350	054366	054382	
PR221DS-I	400	054319	054335	054351	054367	054383	
PR222DS/P-LSI	320	054320	054336	054352	054368	054384	
PR222DS/P-LSI	400	054321	054337	054353	054369	054385	
PR222DS/P-LSIG	320	054322	054338	054354	054370	054386	
PR222DS/P-LSIG	400	054323	054339	054355	054371	054387	
PR223DS	320	059529	059535	059541	059547	059553	
PR223DS	400	059531	059537	059543	059549	059555	

T5 400 – Fixed (F) – 4 Poles - Front terminals (F)

		In	I _s	1SDA.....R1				
				N	S	H	L	V
Thermomagnetic trip unit - TMA		Icu (415 V)	36 kA	50 kA	70 kA	120 kA	200 kA	
N=50%	320 1600...3200		054438	054442	054446	054450	054454	
N=50%	400 2000...4000	054439	054443	054447	054451	054455		
N=100%	320 1600...3200	054477	054479	054481	054483	054485		
N=100%	400 2000...4000	054478	054480	054482	054484	054486		

		In	1SDA.....R1				
			N	S	H	L	V
Electronic trip unit		Icu (415 V)	36 kA	50 kA	70 kA	120 kA	200 kA
PR221DS-LS/I	320		054324	054340	054356	054372	054388
PR221DS-LS/I	400	054325	054341	054357	054373	054389	
PR221DS-I	320	054326	054342	054358	054374	054390	
PR221DS-I	400	054327	054343	054359	054375	054391	
PR222DS/P-LSI	320	054328	054344	054360	054376	054392	
PR222DS/P-LSI	400	054329	054345	054361	054377	054393	
PR222DS/P-LSIG	320	054330	054346	054362	054378	054394	
PR222DS/P-LSIG	400	054331	054347	054363	054379	054395	
PR223DS	320	059530	059536	059542	059548	059554	
PR223DS	400	059532	059538	059544	059550	059556	

see "Abbreviation caption" page 7/2

1SDC21036RF004



T5 630 – Fixed (F) – 3 Poles - Front terminals (F)

		In		1SDA.....R1				
		I ₃		N	S	H	L	V
Thermomagnetic trip unit - TMA		Icu (415 V)		36 kA	50 kA	70 kA	120 kA	200 kA
	500 2500...5000			054456	054461	054465	054469	054473

		In		1SDA.....R1				
		I ₃		N	S	H	L	V
Electronic trip unit		Icu (415 V)		36 kA	50 kA	70 kA	120 kA	200 kA
PR221DS-LS/I	630			054396	054404	054412	054420	054428
PR221DS-I	630			054397	054405	054413	054421	054429
PR222DS/P-LSI	630			054398	054406	054414	054422	054430
PR222DS/P-LSIG	630			054399	054407	054415	054423	054431
PR223DS	630			059533	059539	059545	059551	059557

T5 630 – Fixed (F) – 4 Poles - Front terminals (F)

		In		I ₃		1SDA.....R1				
		I ₃		N	S	H	L	V		
Thermomagnetic trip unit - TMA		Icu (415 V)		36 kA	50 kA	70 kA	120 kA	200 kA		
N=50%	500 2500...5000			054459	054463	054467	054471	054475		
N=100%	500 2500...5000			054487	054489	054491	054493	054495		

		In		1SDA.....R1				
		I ₃		N	S	H	L	V
Electronic trip unit		Icu (415 V)		36 kA	50 kA	70 kA	120 kA	200 kA
PR221DS-LS/I	630			054400	054408	054416	054424	054432
PR221DS-I	630			054401	054409	054417	054425	054433
PR222DS/P-LSI	630			054402	054410	054418	054426	054434
PR222DS/P-LSIG	630			054403	054411	054419	054427	054435
PR223DS	630			059534	059540	059546	059552	059558

Ordering codes

Power distribution circuit-breakers

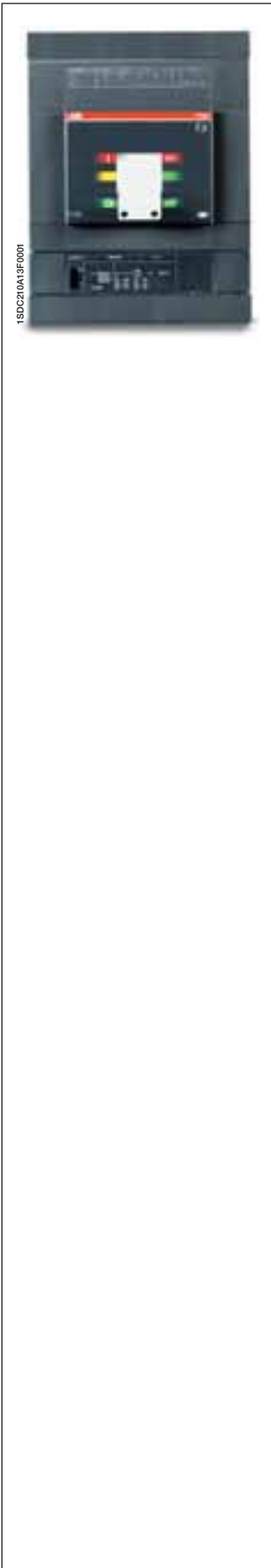

T6 630 – Fixed (F) – 3 Poles - Front terminals (F)

		In	I ₃	1SDA R1			
				N	S	H	L
Thermomagnetic trip unit - TMA		Icu (415 V)		36 kA	50 kA	70 kA	100 kA
	630	3150...6300		060202	060204	060206	060208

		In	1SDA R1			
			N	S	H	L
Electronic trip unit		Icu (415 V)	36 kA	50 kA	70 kA	100 kA
PR221DS-LS/I	630		060226	060236	060246	060256
PR221DS-I	630		060227	060237	060247	060257
PR222DS/P-LSI	630		060228	060238	060248	060258
PR222DS/P-LSIG	630		060229	060239	060249	060259
PR223DS	630		060230	060240	060250	060260

T6 630 – Fixed (F) – 4 Poles - Front terminals (F)

		In	I ₃	1SDA R1			
				N	S	H	L
Thermomagnetic trip unit - TMA		Icu (415 V)		36 kA	50 kA	70 kA	100 kA
N=50%	630	3150...6300		060203	060205	060207	060209
N=100%	630	3150...6300		060210	060211	060212	060213

		In	1SDA R1			
			N	S	H	L
Electronic trip unit		Icu (415 V)	36 kA	50 kA	70 kA	100 kA
PR221DS-LS/I	630		060231	060241	060251	060262
PR221DS-I	630		060232	060242	060252	060263
PR222DS/P-LSI	630		060233	060243	060253	060264
PR222DS/P-LSIG	630		060234	060244	060254	060265
PR223DS	630		060235	060245	060255	060266

T6 800 – Fixed (F) – 3 Poles - Front terminals (F)

		In	I ₃	1SDA R1			
				N	S	H	L
Thermomagnetic trip unit - TMA		Icu (415 V)		36 kA	50 kA	70 kA	100 kA
	800	4000...8000		060214	060216	060218	060220

		In	1SDA R1			
			N	S	H	L
Electronic trip unit		Icu (415 V)	36 kA	50 kA	70 kA	100 kA
PR221DS-LS/I	800		060268	060278	060289	060299
PR221DS-I	800		060269	060279	060290	060300
PR222DS/P-LSI	800		060270	060280	060291	060301
PR222DS/P-LSIG	800		060271	060281	060292	060302
PR223DS	800		060272	060282	060293	060303



T6 800 – Fixed (F) – 4 Poles - Front terminals (F)

		In		1SDA.....R1			
				N	S	H	L
Thermomagnetic trip unit - TMA		Icu (415 V)		36 kA	50 kA	70 kA	100 kA
N=50%	800	4000...8000		060215	060217	060219	060221
N=100%	800	4000...8000		060222	060223	060224	060225

		In		1SDA.....R1			
				N	S	H	L
Electronic trip unit		Icu (415 V)		36 kA	50 kA	70 kA	100 kA
PR221DS-LS/I	800			060273	060283	060294	060305
PR221DS-I	800			060274	060284	060295	060306
PR222DS/P-LSI	800			060275	060285	060296	060307
PR222DS/P-LSIG	800			060276	060286	060297	060308
PR223DS	800			060277	060287	060298	060309

T6 1000 – Fixed (F) – 3 Poles

		In		1SDA.....R1			
				N	S	H	L
Electronic trip unit		Icu (415 V)		36 kA	50 kA	70 kA	100 kA
PR221DS-LS/I	1000			060537	060547	060561	060574
PR221DS-I	1000			060538	060548	060562	060575
PR222DS/P-LSI	1000			060539	060552	060563	060576
PR222DS/P-LSIG	1000			060540	060554	060564	060577
PR223DS	1000			060541	060555	060565	060578

Note: A type of terminal among ES - FC CuAl - R must necessarily be mounted on the T6 1000 A circuit-breaker.

T6 1000 – Fixed (F) – 4 Poles

		In		1SDA.....R1			
				N	S	H	L
Electronic trip unit		Icu (415 V)		36 kA	50 kA	70 kA	100 kA
PR221DS-LS/I	1000			060542	060556	060566	060580
PR221DS-I	1000			060543	060557	060567	060581
PR222DS/P-LSI	1000			060544	060558	060568	060582
PR222DS/P-LSIG	1000			060545	060559	060569	060583
PR223DS	1000			060546	060560	060573	060584

Note: A type of terminal among EF - ES - FC CuAl - R must necessarily be mounted on the T6 1000 A circuit-breaker. If the T6 1000 will be ordered without one of the previous terminal kits, the EF terminals are supplied by default.

Ordering codes

Power distribution circuit-breakers



1SDC210015D0205

T7 800 – Fixed (F) – 3 Poles - Front terminals (F)

		In	1SDA..... R1			
			S	H	L	V
Electronic trip unit		Icu (415 V)	50 kA	70 kA	120 kA	150 kA
PR231/P LS/(¹)	800		061963	062642	062674	062706
PR231/P I(¹)	800		061962	062641	062673	062705
PR232/P LSI	800		061964	062643	062675	062707
PR331/P LSIG	800		061965	062644	062676	062708
PR332/P LI	800		061966	062645	062677	062709
PR332/P LSI	800		061967	062646	062678	062710
PR332/P LSIG	800		061968	062647	062679	062711
PR332/P LSIRc(²)	800		061969	062648	062680	062712

⁽¹⁾ To allow the interchangeability of PR231, T7-T7M circuit-breakers must be ordered specifying extra codes for its interchangeability. See page 7/60.
⁽²⁾ RC protection can be obtained only with 1SDA063869R1 toroid.

T7 800 – Fixed (F) – 4 Poles - Front terminals (F)

		In	1SDA..... R1			
			S	H	L	V
Electronic trip unit		Icu (415 V)	50 kA	70 kA	120 kA	150 kA
PR231/P LS/(¹)	800		061973	062650	062682	062714
PR231/P I(¹)	800		061972	062649	062681	062713
PR232/P LSI	800		061974	062651	062683	062715
PR331/P LSIG	800		061975	062652	062684	062716
PR332/P LI	800		061976	062653	062685	062717
PR332/P LSI	800		061977	062654	062686	062718
PR332/P LSIG	800		061978	062655	062687	062719
PR332/P LSIRc(²)	800		061979	062656	062688	062720

⁽¹⁾ To allow the interchangeability of PR231, T7-T7M circuit-breakers must be ordered specifying extra codes for its interchangeability. See page 7/60.
⁽²⁾ RC protection can be obtained only with 1SDA063869R1 toroid.

T7 1000 – Fixed (F) – 3 Poles - Front terminals (F)

		In	1SDA..... R1			
			S	H	L	V
Electronic trip unit		Icu (415 V)	50 kA	70 kA	120 kA	150 kA
PR231/P LS/(¹)	1000		062738	062770	062802	062834
PR231/P I(¹)	1000		062737	062769	062801	062833
PR232/P LSI	1000		062739	062771	062803	062835
PR331/P LSIG	1000		062740	062772	062804	062836
PR332/P LI	1000		062741	062773	062805	062837
PR332/P LSI	1000		062742	062774	062806	062838
PR332/P LSIG	1000		062743	062775	062807	062839
PR332/P LSIRc(²)	1000		062744	062776	062808	062840

⁽¹⁾ To allow the interchangeability of PR231, T7-T7M circuit-breakers must be ordered specifying extra codes for its interchangeability. See page 7/60.
⁽²⁾ RC protection can be obtained only with 1SDA063869R1 toroid.

T7 1000 – Fixed (F) – 4 Poles - Front terminals (F)

		In	1SDA..... R1			
			S	H	L	V
Electronic trip unit		Icu (415 V)	50 kA	70 kA	120 kA	150 kA
PR231/P LS/(¹)	1000		062746	062778	062810	062842
PR231/P I(¹)	1000		062745	062777	062809	062841
PR232/P LSI	1000		062747	062779	062811	062843
PR331/P LSIG	1000		062748	062780	062812	062844
PR332/P LI	1000		062749	062781	062813	062845
PR332/P LSI	1000		062750	062782	062814	062846
PR332/P LSIG	1000		062751	062783	062815	062847
PR332/P LSIRc(²)	1000		062752	062784	062816	062848

⁽¹⁾ To allow the interchangeability of PR231, T7-T7M circuit-breakers must be ordered specifying extra codes for its interchangeability. See page 7/60.
⁽²⁾ RC protection can be obtained only with 1SDA063869R1 toroid.

see "Abbreviation caption" page 7/2

1SDC210015D0205



T7 1250 – Fixed (F) – 3 Poles - Front terminals (F)

		In	1SDA.....R1			
			S	H	L	V
Electronic trip unit		Icu (415 V)	50 kA	70 kA	120 kA	150 kA
PR231/P LS/I ⁽¹⁾	1250		062866	062898	062930	062962
PR231/P I ⁽¹⁾	1250		062865	062897	062929	062961
PR232/P LSI	1250		062867	062899	062931	062963
PR331/P LSIG	1250		062868	062900	062932	062964
PR332/P LI	1250		062869	062901	062933	062965
PR332/P LSI	1250		062870	062902	062934	062966
PR332/P LSIG	1250		062871	062903	062935	062967
PR332/P LSIRc ⁽²⁾	1250		062872	062904	062936	062968

⁽¹⁾ To allow the interchangeability of PR231, T7-T7M circuit-breakers must be ordered specifying extra codes for its interchangeability. See page 7/60.

⁽²⁾ RC protection can be obtained only with 1SDA063869R1 toroid.

T7 1250 – Fixed (F) – 4 Poles - Front terminals (F)

		In	1SDA.....R1			
			S	H	L	V
Electronic trip unit		Icu (415 V)	50 kA	70 kA	120 kA	150 kA
PR231/P LS/I ⁽¹⁾	1250		062874	062906	062938	062970
PR231/P I ⁽¹⁾	1250		062873	062905	062937	062969
PR232/P LSI	1250		062875	062907	062939	062971
PR331/P LSIG	1250		062876	062908	062940	062972
PR332/P LI	1250		062877	062909	062941	062973
PR332/P LSI	1250		062878	062910	062942	062974
PR332/P LSIG	1250		062879	062911	062943	062975
PR332/P LSIRc ⁽²⁾	1250		062880	062912	062944	062976

⁽¹⁾ To allow the interchangeability of PR231, T7-T7M circuit-breakers must be ordered specifying extra codes for its interchangeability. See page 7/60.

⁽²⁾ RC protection can be obtained only with 1SDA063869R1 toroid.

T7 1600 – Fixed (F) – 3 Poles - Front terminals (F)

		In	1SDA.....R1		
			S	H	L
Electronic trip unit		Icu (415 V)	50 kA	70 kA	120 kA
PR231/P LS/I ⁽¹⁾	1600		062994	063026	063058
PR231/P I ⁽¹⁾	1600		062993	063025	063057
PR232/P LSI	1600		062995	063027	063059
PR331/P LSIG	1600		062996	063028	063060
PR332/P LI	1600		062997	063029	063061
PR332/P LSI	1600		062998	063030	063062
PR332/P LSIG	1600		062999	063031	063063
PR332/P LSIRc ⁽²⁾	1600		063000	063032	063064

⁽¹⁾ To allow the interchangeability of PR231, T7-T7M circuit-breakers must be ordered specifying extra codes for its interchangeability. See page 7/60.

⁽²⁾ RC protection can be obtained only with 1SDA063869R1 toroid.

T7 1600 – Fixed (F) – 4 Poles - Front terminals (F)

		In	1SDA.....R1		
			S	H	L
Electronic trip unit		Icu (415 V)	50 kA	70 kA	120 kA
PR231/P LS/I ⁽¹⁾	1600		063002	063034	063066
PR231/P I ⁽¹⁾	1600		063001	063033	063065
PR232/P LSI	1600		063003	063035	063067
PR331/P LSIG	1600		063004	063036	063068
PR332/P LI	1600		063005	063037	063069
PR332/P LSI	1600		063006	063038	063070
PR332/P LSIG	1600		063007	063039	063071
PR332/P LSIRc ⁽²⁾	1600		063008	063040	063072

⁽¹⁾ To allow the interchangeability of PR231, T7-T7M circuit-breakers must be ordered specifying extra codes for its interchangeability. See page 7/60.

⁽²⁾ RC protection can be obtained only with 1SDA063869R1 toroid.

see "Abbreviation caption" page 7/2

Ordering codes

Power distribution circuit-breakers



1SDC210015D0205

T7 800 M – Fixed (F) – 3 Poles - Front terminals (F)

		In	1SDA..... R1			
			S	H	L	V
Electronic trip unit	Icu (415 V)	50 kA	70 kA	120 kA	150 kA	
PR231/P LS/(¹)	800	061981	062658	062690	062722	
PR231/P I(¹)	800	061980	062657	062689	062721	
PR232/P LSI	800	061982	062659	062691	062723	
PR331/P LSIG	800	061983	062660	062692	062724	
PR332/P LI	800	061984	062661	062693	062725	
PR332/P LSI	800	061985	062662	062694	062726	
PR332/P LSIG	800	061986	062663	062695	062727	
PR332/P LSIRc(²)	800	061987	062664	062696	062728	

⁽¹⁾ To allow the interchangeability of PR231, T7-T7M circuit-breakers must be ordered specifying extra codes for its interchangeability. See page 7/60.
⁽²⁾ RC protection can be obtained only with 1SDA063869R1 toroid.

T7 800 M – Fixed (F) – 4 Poles - Front terminals (F)

		In	1SDA..... R1			
			S	H	L	V
Electronic trip unit	Icu (415 V)	50 kA	70 kA	120 kA	150 kA	
PR231/P LS/(¹)	800	061989	062666	062698	062730	
PR231/P I(¹)	800	061988	062665	062697	062729	
PR232/P LSI	800	061990	062667	062699	062731	
PR331/P LSIG	800	061991	062668	062700	062732	
PR332/P LI	800	061992	062669	062701	062733	
PR332/P LSI	800	061993	062670	062702	062734	
PR332/P LSIG	800	061994	062671	062703	062735	
PR332/P LSIRc(²)	800	061995	062672	062704	062736	

⁽¹⁾ To allow the interchangeability of PR231, T7-T7M circuit-breakers must be ordered specifying extra codes for its interchangeability. See page 7/60.
⁽²⁾ RC protection can be obtained only with 1SDA063869R1 toroid.

T7 1000 M – Fixed (F) – 3 Poles - Front terminals (F)

		In	1SDA..... R1			
			S	H	L	V
Electronic trip unit	Icu (415 V)	50 kA	70 kA	120 kA	150 kA	
PR231/P LS/(¹)	1000	062754	062786	062818	062850	
PR231/P I(¹)	1000	062753	062785	062817	062849	
PR232/P LSI	1000	062755	062787	062819	062851	
PR331/P LSIG	1000	062756	062788	062820	062852	
PR332/P LI	1000	062757	062789	062821	062853	
PR332/P LSI	1000	062758	062790	062822	062854	
PR332/P LSIG	1000	062759	062791	062823	062855	
PR332/P LSIRc(²)	1000	062760	062792	062824	062856	

⁽¹⁾ To allow the interchangeability of PR231, T7-T7M circuit-breakers must be ordered specifying extra codes for its interchangeability. See page 7/60.
⁽²⁾ RC protection can be obtained only with 1SDA063869R1 toroid.

T7 1000 M – Fixed (F) – 4 Poles - Front terminals (F)

		In	1SDA..... R1			
			S	H	L	V
Electronic trip unit	Icu (415 V)	50 kA	70 kA	120 kA	150 kA	
PR231/P LS/(¹)	1000	062762	062794	062826	062858	
PR231/P I(¹)	1000	062761	062793	062825	062857	
PR232/P LSI	1000	062763	062795	062827	062859	
PR331/P LSIG	1000	062764	062796	062828	062860	
PR332/P LI	1000	062765	062797	062829	062861	
PR332/P LSI	1000	062766	062798	062830	062862	
PR332/P LSIG	1000	062767	062799	062831	062863	
PR332/P LSIRc(²)	1000	062768	062800	062832	062864	

⁽¹⁾ To allow the interchangeability of PR231, T7-T7M circuit-breakers must be ordered specifying extra codes for its interchangeability. See page 7/60.
⁽²⁾ RC protection can be obtained only with 1SDA063869R1 toroid.

see "Abbreviation caption" page 7/2

1SDC210015D0201



T7 1250 M – Fixed (F) – 3 Poles – Front terminals (F)

		In	1SDA.....R1			
			S	H	L	V
Electronic trip unit		Icu (415 V)	50 kA	70 kA	120 kA	150 kA
PR231/P LS/I ⁽¹⁾	1250		062882	062914	062946	062978
PR231/P I ⁽¹⁾	1250		062881	062913	062945	062977
PR232/P LSI	1250		062883	062915	062947	062979
PR331/P LSIG	1250		062884	062916	062948	062980
PR332/P LI	1250		062885	062917	062949	062981
PR332/P LSI	1250		062886	062918	062950	062982
PR332/P LSIG	1250		062887	062919	062951	062983
PR332/P LSIRc ⁽²⁾	1250		062888	062920	062952	062984

⁽¹⁾ To allow the interchangeability of PR231, T7-T7M circuit-breakers must be ordered specifying extra codes for its interchangeability. See page 7/60.
⁽²⁾ RC protection can be obtained only with 1SDA063869R1 toroid.

T7 1250 M – Fixed (F) – 4 Poles – Front terminals (F)

		In	1SDA.....R1			
			S	H	L	V
Electronic trip unit		Icu (415 V)	50 kA	70 kA	120 kA	150 kA
PR231/P LS/I ⁽¹⁾	1250		062890	062922	062954	062986
PR231/P I ⁽¹⁾	1250		062889	062921	062953	062985
PR232/P LSI	1250		062891	062923	062955	062987
PR331/P LSIG	1250		062892	062924	062956	062988
PR332/P LI	1250		062893	062925	062957	062989
PR332/P LSI	1250		062894	062926	062958	062990
PR332/P LSIG	1250		062895	062927	062959	062991
PR332/P LSIRc ⁽²⁾	1250		062896	062928	062960	062992

⁽¹⁾ To allow the interchangeability of PR231, T7-T7M circuit-breakers must be ordered specifying extra codes for its interchangeability. See page 7/60.
⁽²⁾ RC protection can be obtained only with 1SDA063869R1 toroid.

T7 1600 M – Fixed (F) – 3 Poles – Front terminals (F)

		In	1SDA.....R1		
			S	H	L
Electronic trip unit		Icu (415 V)	50 kA	70 kA	120 kA
PR231/P LS/I ⁽¹⁾	1600		063010	063042	063074
PR231/P I ⁽¹⁾	1600		063009	063041	063073
PR232/P LSI	1600		063011	063043	063075
PR331/P LSIG	1600		063012	063044	063076
PR332/P LI	1600		063013	063045	063077
PR332/P LSI	1600		063014	063046	063078
PR332/P LSIG	1600		063015	063047	063079
PR332/P LSIRc ⁽²⁾	1600		063016	063048	063080

⁽¹⁾ To allow the interchangeability of PR231, T7-T7M circuit-breakers must be ordered specifying extra codes for its interchangeability. See page 7/60.
⁽²⁾ RC protection can be obtained only with 1SDA063869R1 toroid.

T7 1600 M – Fixed (F) – 4 Poles – Front terminals (F)

		In	1SDA.....R1		
			S	H	L
Electronic trip unit		Icu (415 V)	50 kA	70 kA	120 kA
PR231/P LS/I ⁽¹⁾	1600		063018	063050	063082
PR231/P I ⁽¹⁾	1600		063017	063049	063081
PR232/P LSI	1600		063019	063051	063083
PR331/P LSIG	1600		063020	063052	063084
PR332/P LI	1600		063021	063053	063085
PR332/P LSI	1600		063022	063054	063086
PR332/P LSIG	1600		063023	063055	063087
PR332/P LSIRc ⁽²⁾	1600		063024	063056	063088

⁽¹⁾ To allow the interchangeability of PR231, T7-T7M circuit-breakers must be ordered specifying extra codes for its interchangeability. See page 7/60.
⁽²⁾ RC protection can be obtained only with 1SDA063869R1 toroid.

see "Abbreviation caption" page 7/2

Ordering codes

Circuit-breakers for zone selectivity

T4L 250 – Fixed (F) - Front terminals (F)

<i>Electronic trip unit</i>	<i>Icu (415 V)</i>	1SDA R1	
		3 poles	4 poles
PR223EF	160	059477	059478
PR223EF	250	059479	059480

T4L 250 – Fixed (F) - Terminals for copper cables FC Cu 1000 V (AC)

<i>Electronic trip unit</i>	<i>Icu (415 V)</i>	1SDA R1	
		3 poles	4 poles
PR223EF	160	064270	064271
PR223EF	250	064272	064273

T4L 320 – Fixed (F) - Front terminals (F)

<i>Electronic trip unit</i>	<i>Icu (415 V)</i>	1SDA R1	
		3 poles	4 poles
PR223EF	320	059481	059482

T5L 400 – Fixed (F) - Front terminals (F)

<i>Electronic trip unit</i>	<i>Icu (415 V)</i>	1SDA R1	
		3 poles	4 poles
PR223EF	320	059483	059484
PR223EF	400	059485	059486

T5L 400 – Fixed (F) - Terminals for copper cables FC Cu 1000 V (AC)

<i>Electronic trip unit</i>	<i>Icu (415 V)</i>	1SDA R1	
		3 poles	4 poles
PR223EF	320	064274	064275
PR223EF	400	064276	064277

T5L 630 – Fixed (F) - Front terminals (F)

<i>Electronic trip unit</i>	<i>Icu (415 V)</i>	1SDA R1	
		3 poles	4 poles
PR223EF	630	059487	059488

T5L 630 – Fixed (F) - Terminals for copper cables FC Cu 1000 V (AC)

<i>Electronic trip unit</i>	<i>Icu (415 V)</i>	1SDA R1	
		3 poles	4 poles
PR223EF	630	064278	064279

T6L 630 – Fixed (F) - Front terminals (F)

<i>Electronic trip unit</i>	In	Icu (415 V)	1SDA R1	
			3 poles	4 poles
PR223EF	630		100 kA	100 kA
			060261	060267

T6L 800 – Fixed (F) - Front terminals (F)

<i>Electronic trip unit</i>	In	Icu (415 V)	1SDA R1	
			3 poles	4 poles
PR223EF	800		100 kA	100 kA
			060304	060310

T6L 1000 – Fixed (F)

<i>Electronic trip unit</i>	In	Icu (415 V)	1SDA R1	
			3 poles	4 poles
PR223EF	1000		100 kA	100 kA
			060579	060585

Note: A type of terminal among ES - FC CuAl - R must be mounted on the T6 1000 A circuit-breaker.

Ordering codes

Motor protection circuit-breakers

1SDC210309R0004



T2 160 – Fixed (F) – 3 Poles - Front terminals (F)

		In		1SDA.....R1			
		I ₃		N	S	H	L
Magnetic only trip unit - MF and MA		Icu (415 V)		36 kA	50 kA	70 kA	85 kA
	1	13		053110	053121	053132	053143
	1.6	21		053111	053122	053133	053144
	2	26		053112	053123	053134	053145
	2.5	33		053113	053124	053135	053146
	3.2	42		053114	053125	053136	053147
	4	52		053115	053126	053137	053148
	5	65		053116	053127	053138	053149
	6.5	84		053117	053128	053139	053150
	8.5	110		053118	053129	053140	053151
	11	145		053119	053130	053141	053152
	12.5	163		053120	053131	053142	053153
	20	120...240		051207	051216	051224	051232
	32	192...384		051208	051217	051225	051233
	52	312...624		051209	051218	051226	051234
	80	480...960		051210	051219	051227	051235
	100	600...1200		051211	051220	051228	051236

		In		1SDA.....R1			
		I ₃		N	S	H	L
Electronic trip unit		Icu (415 V)		36 kA	50 kA	70 kA	85 kA
PR221DS-I	10			051163	051174	051184	051194
PR221DS-I	25			051164	051175	051185	051195
PR221DS-I	63			051165	051176	051186	051196
PR221DS-I	100			051166	051177	051187	051197
PR221DS-I	160			051168	051178	051188	051198
PR221MP	40			065340	065343	065346	065349
PR221MP	63			065341	065344	065347	065350
PR221MP	100			065342	065345	065348	065351

Note: The trip coil of the T2 circuit-breaker with PR221DS electronic trip unit is housed in the right slot.
 For T2 with PR 221DS the following groups of auxiliary contacts are available:
 - 1SDA053704R1 Aux-C 1S51-1Q-1SY
 - 1SDA055504R1 Aux-C 2Q-1SY

T3 250 – Fixed (F) – 3 Poles - Front terminals (F)

		In		1SDA.....R1			
		I ₃		N	S		
Magnetic only trip unit - MA		Icu (415 V)		36 kA	50 kA		
	100	600...1200		051315	051320		
	125	750...1500		051316	051321		
	160	960...1920		051317	051322		
	200	1200...2400		051318	051323		

Note: T2, T4, T5 and T6 in the three-pole version equipped with PR221DS-I electronic trip units and T7 in the three-pole version equipped with PR231/P-I electronic trip units, can be used for motor protection.

see "Abbreviation caption" page 7/2

1SDC210309F0004



T4 250 – Fixed (F) – 3 Poles - Front terminals (F)

		In		1SDA R1		
		I ₃		N	S	L
Magnetic only trip unit - MA		Icu (415 V)		36 kA	50 kA	120 kA
	10	60...140		055068	055071	055074
	25	150...350		055069	055072	055075
	52	312...728		055070	055073	055076
	80	480...1120		054296	054302	054308
	100	600...1400		054297	054303	054309
	125	750...1750		054298	054304	054310
	160	960...2240		054299	054305	054311
	200	1200..2800		054300	054306	054312

		In		1SDA R1		
		I ₃		N	S	L
Electronic trip unit for motor protection		Icu (415 V)		36 kA	50 kA	120 kA
PR222MP	100			054522	054525	054528
PR222MP	160			054523	054526	054529
PR222MP	200			054524	054527	054530

		In		1SDA R1				
		I ₃		N	S	H	L	V
Electronic trip unit		Icu (415 V)		36 kA	50 kA	70 kA	120 kA	200 kA
PR221DS-I	100			054000	054024	054048	054072	054096
PR221DS-I	160			054001	054025	054049	054073	054097
PR221DS-I	250			054002	054026	054050	054074	054098

T4 320 – Fixed (F) – 3 Poles - Front terminals (F)

		In		1SDA R1				
		I ₃		N	S	H	L	V
Electronic trip unit		Icu (415 V)		36 kA	50 kA	70 kA	120 kA	200 kA
PR221DS-I	320			054118	054126	054134	054142	054150

Note: T2, T4, T5 and T6 in the three-pole version equipped with PR221DS-I electronic trip units and T7 in the three-pole version equipped with PR231/P-I electronic trip units, can be used for motor protection.

see "Abbreviation caption" page 7/2

Ordering codes

Motor protection circuit-breakers

1SDC21036F0004



T5 400 – Fixed (F) – 3 Poles - Front terminals (F)

		In	1SDA.....R1		
			N	S	L
Electronic trip unit for motor protection		Icu (415 V)	36 kA	50 kA	120 kA
PR222MP	320		054551	054553	054555
PR222MP	400		054552	054554	054556

		In	1SDA.....R1				
			N	S	H	L	V
Electronic trip unit		Icu (415 V)	36 kA	50 kA	70 kA	120 kA	200 kA
PR221DS-I	320		054318	054334	054350	054366	054382
PR221DS-I	400		054319	054335	054351	054367	054383

T5 630 – Fixed (F) – 3 Poles - Front terminals (F)

		In	1SDA.....R1				
			N	S	H	L	V
Electronic trip unit		Icu (415 V)	36 kA	50 kA	70 kA	120 kA	200 kA
PR221DS-I	630		054397	054405	054413	054421	054429

T6 630 – Fixed (F) – 3 Poles - Front terminals (F)

		In	1SDA.....R1			
			N	S	H	L
Electronic trip unit		Icu (415 V)	36 kA	50 kA	70 kA	100 kA
PR221DS-I	630		060227	060237	060247	060257

T6 800 – Fixed (F) – 3 Poles - Front terminals (F)

		In	1SDA.....R1			
			N	S	H	L
Electronic trip unit for motor protection		Icu (415 V)	36 kA	50 kA	70 kA	100 kA
PR222MP	630		060311	060312	060313	060314

		In	1SDA.....R1			
			N	S	H	L
Electronic trip unit		Icu (415 V)	36 kA	50 kA	70 kA	100 kA
PR221DS-I	800		060269	060279	060290	060300

Note: T2, T4, T5 and T6 in the three-pole version equipped with PR221DS-I electronic trip units and T7 in the three-pole version equipped with PR231/P-I electronic trip units, can be used for motor protection.

see "Abbreviation caption" page 7/2

T7 800 – Fixed (F) – 3 Poles - Front terminals (F)

		1SDA..... R1			
		S	H	L	V
Electronic trip unit	Icu (415 V)	50 kA	70 kA	120 kA	150 kA
PR231/P I	800	061962	062641	062673	062705

T7 1000 – Fixed (F) – 3 Poles - Front terminals (F)

		1SDA..... R1			
		S	H	L	V
Electronic trip unit	Icu (415 V)	50 kA	70 kA	120 kA	150 kA
PR231/P I	1000	062737	062769	062801	062833

T7 1250 – Fixed (F) – 3 Poles - Front terminals (F)

		1SDA..... R1			
		S	H	L	V
Electronic trip unit	Icu (415 V)	50 kA	70 kA	120 kA	150 kA
PR231/P I	1250	062865	062897	062929	062961

T7 1600 – Fixed (F) – 3 Poles - Front terminals (F)

		1SDA..... R1			
		S	H	L	V
Electronic trip unit	Icu (415 V)	50 kA	70 kA	120 kA	150 kA
PR231/P I	1600	062993	063025	063057	

T7 800 M – Fixed (F) – 3 Poles - Front terminals (F)

		1SDA..... R1			
		S	H	L	V
Electronic trip unit	Icu (415 V)	50 kA	70 kA	120 kA	150 kA
PR231/P I	800	061980	062657	062689	062721

T7 1000 M – Fixed (F) – 3 Poles - Front terminals (F)

		1SDA..... R1			
		S	H	L	V
Electronic trip unit	Icu (415 V)	50 kA	70 kA	120 kA	150 kA
PR231/P I	1000	062753	062785	062817	062849

T7 1250 M – Fixed (F) – 3 Poles - Front terminals (F)

		1SDA..... R1			
		S	H	L	V
Electronic trip unit	Icu (415 V)	50 kA	70 kA	120 kA	150 kA
PR231/P I	1250	062851	062913	062945	062977

T7 1600 M – Fixed (F) – 3 Poles - Front terminals (F)

		1SDA..... R1			
		S	H	L	V
Electronic trip unit	Icu (415 V)	50 kA	70 kA	120 kA	150 kA
PR231/P I	1600	063009	063041	063073	

Note: T2, T4, T5 and T6 in the three-pole version equipped with PR221DS-I electronic trip units and T7 in the three-pole version equipped with PR231/P-I electronic trip units, can be used for motor protection.

see "Abbreviation caption" page 7/2

Ordering codes

Circuit-breakers for use up to 1150 V AC and 1000 V DC

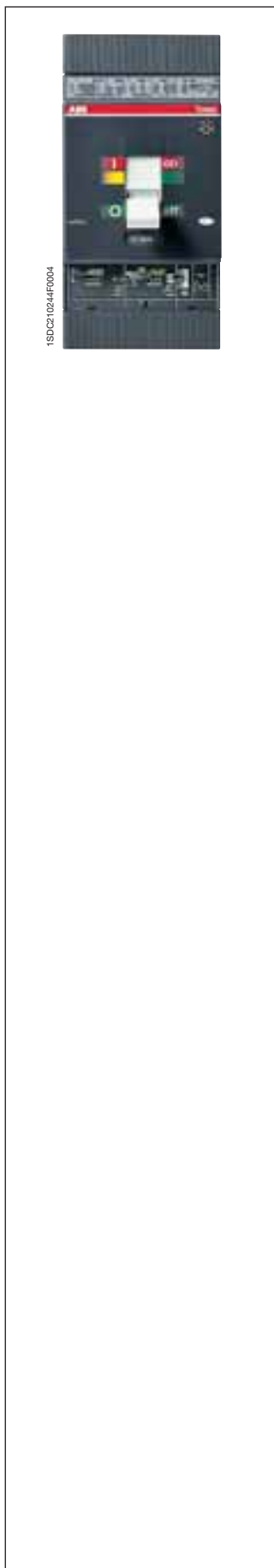

T4 250 – Fixed (F) – 3 Poles - Front terminals for copper cables (FC Cu)

		In	1SDA R1	
			L	V
		Icu (1000 V AC)	12 kA	20 kA
		Icu (1150 V AC)	12 kA	12 kA
Electronic trip unit				
PR221DS-LS/I	100		054505	054513
PR221DS-I	100		054506	054514
PR222DS/P-LSI	100		054507	054515
PR222DS/P-LSIG	100		054508	054516
PR221DS-LS/I	250		054509	054517
PR221DS-I	250		054510	054518
PR222DS/P-LSI	250		054511	054519
PR222DS/P-LSIG	250		054512	054520
PR222MP	100		063434	
PR222MP	160		063435	
PR222MP	200		063436	

T4 250 – Fixed (F) – 4 Poles - Front terminals for copper cables (FC Cu)

		In	1SDA R1	
			L	V
		Icu (1000 V AC)	12 kA	20 kA
		Icu (1150 V AC)	12 kA	12 kA
Electronic trip unit				
PR221DS-LS/I	100		063418	063426
PR221DS-I	100		063419	063427
PR222DS/P-LSI	100		063420	063428
PR222DS/P-LSIG	100		063421	063429
PR221DS-LS/I	250		063422	063430
PR221DS-I	250		063423	063431
PR222DS/P-LSI	250		063424	063432
PR222DS/P-LSIG	250		063425	063433

T4 250 – Fixed (F) – 3 Poles - Front terminals for copper cables (FC Cu)

		In	I _s	1SDA R1	
				V	
		Icu (1000 V AC)	20 kA		
		Icu (1150 V AC)	12 kA		
Thermomagnetic trip unit - TMD and TMA					
	32 320		063410		
	50 500		063411		
	80 400...800		063412		
	100 500...1000		063413		
	125 625...1250		063414		
	160 800...1600		063415		
	200 1000...2000		063416		
	250 1250...2500		063417		



1SDC210244F0004

T4 250 – Fixed (F) – 4 Poles - Front terminals for copper cables (FC Cu)

		In	I ₃	1SDA.....R1				
				V				
Thermomagnetic trip unit - TMD and TMA				Icu (1000 V AC)	20 kA			
				Icu (1150 V AC)	12 kA			
				Icu (1000 V DC)	40 kA			
	32	320			054497			
	50	500			054498			
	80	400...800			054499			
	100	500...1000			054500			
	125	625...1250			054501			
	160	800...1600			054502			
	200	1000...2000			054503			
	250	1250...2500			054504			



1SDC210247F0004

T5 400 – Fixed (F) – 3 Poles - Front terminals for copper cables (FC Cu)

		In	1SDA.....R1					
				L	V			
Electronic trip unit				Icu (1000 V AC)	12 kA	20 kA		
				Icu (1150 V AC)		12 kA		
PR221DS-LS/I	320				063477	063485		
PR221DS-I	320				063478	063486		
PR222DS/P-LSI	320				063479	063487		
PR222DS/P-LSIG	320				063480	063488		
PR221DS-LS/I	400				054535	054539		
PR221DS-I	400				054536	054540		
PR222DS/P-LSI	400				054537	054541		
PR222DS/P-LSIG	400				054538	054542		
PR222MP	320				063456			
PR222MP	400				063457			

T5 400 – Fixed (F) – 4 Poles - Front terminals for copper cables (FC Cu)

		In	1SDA.....R1					
				L	V			
Electronic trip unit				Icu (1000 V AC)	12 kA	20 kA		
				Icu (1150 V AC)		12 kA		
PR221DS-LS/I	320				063481	063489		
PR221DS-I	320				063482	063490		
PR222DS/P-LSI	320				063483	063491		
PR222DS/P-LSIG	320				063484	063492		
PR221DS-LS/I	400				063440	063444		
PR221DS-I	400				063441	063445		
PR222DS/P-LSI	400				063442	063446		
PR222DS/P-LSIG	400				063443	063447		

Ordering codes

Circuit-breakers for use up to 1150 V AC and 1000 V DC

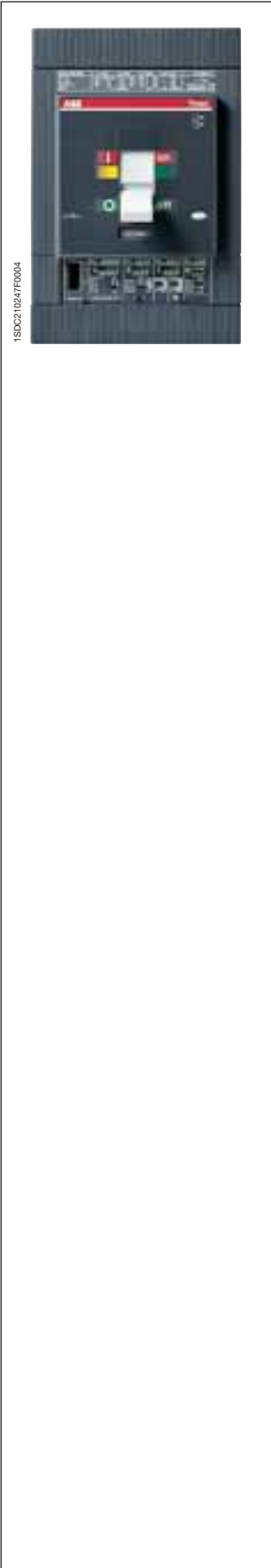

T5 400 – Fixed (F) – 3 Poles - Front terminals for copper cables (FC Cu)

		In	I₃	1SDA.....R1						
				V						
Thermomagnetic trip unit - TMA	Icu (1000 V AC)	20 kA								
	Icu (1150 V AC)	12 kA								
	320 1600...3200	063437								
	400 2000...4000	063438								

T5 400 – Fixed (F) – 4 Poles - Front terminals for copper cables (FC Cu)

		In	I₃	1SDA.....R1						
				V						
Thermomagnetic trip unit - TMA	Icu (1000 V AC)	20 kA								
	Icu (1150 V AC)	12 kA								
	Icu (1000 V DC)	40 kA								
	320 1600...3200	054531								
	400 2000...4000	054532								

1SDC210247F0004



T5 630 – Fixed (F) – 3 Poles - Front terminals for copper cables (FC Cu)

		In	1SDA.....R1						
				L	V				
Electronic trip unit			Icu (1000 V AC) Icu (1150 V AC)	12 kA	20 kA 12 kA				
PR221DS-LS/I	630			054543	054547				
PR221DS-I	630			054544	054548				
PR222DS/P-LSI	630			054545	054549				
PR222DS/P-LSIG	630			054546	054550				

T5 630 – Fixed (F) – 4 Poles - Front terminals for copper cables (FC Cu)

		In	1SDA.....R1						
				L	V				
Electronic trip unit			Icu (1000 V AC) Icu (1150 V AC)	12 kA	20 kA 12 kA				
PR221DS-LS/I	630			063448	063452				
PR221DS-I	630			063449	063453				
PR222DS/P-LSI	630			063450	063454				
PR222DS/P-LSIG	630			063451	063455				

T5 630 – Fixed (F) – 3 Poles - Front terminals for copper cables (FC Cu)

		In	I ₃	1SDA.....R1					
					V				
Thermomagnetic trip unit - TMA				Icu (1000 V AC) Icu (1150 V AC)	20 kA 12 kA				
	500 2500...5000				063439				

T5 630 – Fixed (F) – 4 Poles - Front terminals for copper cables (FC Cu)

		In	I ₃	1SDA.....R1					
					V				
Thermomagnetic trip unit - TMA				Icu (1000 V AC) Icu (1150 V AC) Icu (1000 V DC)	20 kA 12 kA 40 kA				
	500 2500...5000				054533				

Ordering codes

Circuit-breakers for use up to 1150 V AC and 1000 V DC

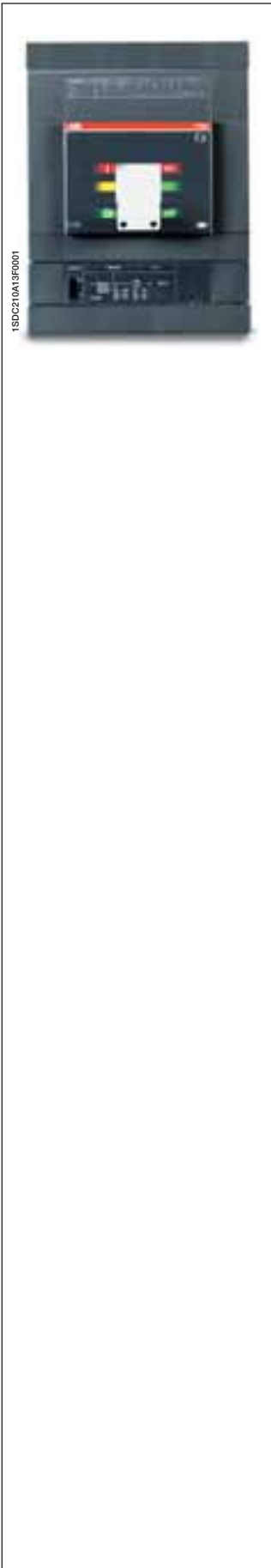

T6 630 – Fixed (F) – 3 Poles - Front terminals (F)

		In			1SDA R1				
				L					
<i>Electronic trip unit</i>			Icu (1000 V AC)	12 kA					
PR221DS-LS/I	630			060319					
PR221DS-I	630			060320					
PR222DS/P-LSI	630			060321					
PR222DS/P-LSIG	630			060322					

T6 630 – Fixed (F) – 4 Poles - Front terminals (F)

		In	I ₃			1SDA R1				
					L					
<i>Thermomagnetic trip unit - TMA</i>				Icu (1000 V AC)	12 kA					
				Icu (1000 V DC)	40 kA					
	630	3150...6300			060315					

T6 800 – Fixed (F) – 3 Poles - Front terminals (F)

		In			1SDA R1				
				L					
<i>Electronic trip unit</i>			Icu (1000 V AC)	12 kA					
PR221DS-LS/I	800			060323					
PR221DS-I	800			060324					
PR222DS/P-LSI	800			060325					
PR222DS/P-LSIG	800			060326					

T6 800 – Fixed (F) – 4 Poles - Front terminals (F)

		In	I ₃			1SDA R1				
					L					
<i>Thermomagnetic trip unit - TMA</i>				Icu (1000 V AC)	12 kA					
				Icu (1000 V DC)	40 kA					
	800	4000...8000			060317					

Ordering codes

Switch disconnectors



1SDC210302F0004

T1D 160 – Fixed (F) - Front terminals for copper cables (FC Cu)

		1SDA R1	
		3 poles	4 poles
	Icw	2 kA	2 kA
		051325	051326



1SDC210304F0004

T3D 250 – Fixed (F) - Front terminals (F)

		1SDA R1	
		3 poles	4 poles
	Icw	3.6 kA	3.6 kA
		051327	051328



1SDC210305F0004

T4D 250 – Fixed (F) - Front terminals (F)

		1SDA R1	
		3 poles	4 poles
	Icw	3.6 kA	3.6 kA
		057172	057173

T4D 320 – Fixed (F) - Front terminals (F)

		1SDA R1	
		3 poles	4 poles
	Icw	3.6 kA	3.6 kA
		054597	054598



1SDC210306F0004

T5D 400 – Fixed (F) - Front terminals (F)

		1SDA R1	
		3 poles	4 poles
	Icw	6 kA	6 kA
		054599	054600

T5D 630 – Fixed (F) - Front terminals (F)

		1SDA R1	
		3 poles	4 poles
	Icw	6 kA	6 kA
		054601	054602

see "Abbreviation caption" page 7/2

Ordering codes

Switch disconnectors



1SDC210P04F0001

T6D 630 – Fixed (F) - Front terminals (F)

		1SDA R1	
		3 poles	4 poles
	lcw	15 kA	15 kA
		060343	060344

T6D 800 – Fixed (F) - Front terminals (F)

		1SDA R1	
		3 poles	4 poles
	lcw	15 kA	15 kA
		060345	060346

T6D 1000 – Fixed (F)

		1SDA R1	
		3 poles	4 poles
	lcw	15 kA	15 kA
		060594	060595

Note: A type of terminal among ES - FC CuAl - R must necessarily be mounted on the 1000 A circuit-breaker.



1SDC210P05F0001

T7D 1000 – Fixed (F) - Front terminals (F)

		1SDA R1	
		3 poles	4 poles
	lcw	20 kA	20 kA
		062032	062033

T7D 1250 – Fixed (F) - Front terminals (F)

		1SDA R1	
		3 poles	4 poles
	lcw	20 kA	20 kA
		062036	062037

T7D 1600 – Fixed (F) - Front terminals (F)

		1SDA R1	
		3 poles	4 poles
	lcw	20 kA	20 kA
		062040	062041

see "Abbreviation caption" page 7/2

1SDC21009F0001



T7D 1000 M – Fixed (F) - Front terminals (F)

		1SDA R1	
		3 poles	4 poles
	Icw	20 kA	20 kA
		062034	062035

T7D 1250 M – Fixed (F) - Front terminals (F)

		1SDA R1	
		3 poles	4 poles
	Icw	20 kA	20 kA
		062038	062039

T7D 1600 M – Fixed (F) - Front terminals (F)

		1SDA R1	
		3 poles	4 poles
	Icw	20 kA	20 kA
		062042	062043

Ordering codes

Breaking units

T4 250 - F = Front terminals

	1SDA R1	
	3 poles	4 poles
T4N 250 Breaking unit	054557	054562
T4S 250 Breaking unit	054558	054563
T4H 250 Breaking unit	054559	054564
T4L 250 Breaking unit	054560	054565
T4V 250 Breaking unit	054561	054566

T4 320 - F = Front terminals

	1SDA R1	
	3 poles	4 poles
T4N 320 Breaking unit	054567	054572
T4S 320 Breaking unit	054568	054573
T4H 320 Breaking unit	054569	054574
T4L 320 Breaking unit	054570	054575
T4V 320 Breaking unit	054571	054576

T5 400 - F = Front terminals

	1SDA R1	
	3 poles	4 poles
T5N 400 Breaking unit	054577	054582
T5S 400 Breaking unit	054578	054583
T5H 400 Breaking unit	054579	054584
T5L 400 Breaking unit	054580	054585
T5V 400 Breaking unit	054581	054586

T5 630 - F = Front terminals

	1SDA R1	
	3 poles	4 poles
T5N 630 Breaking unit	054587	054592
T5S 630 Breaking unit	054588	054593
T5H 630 Breaking unit	054589	054594
T5L 630 Breaking unit	054590	054595
T5V 630 Breaking unit	054591	054596

T6 630 - F = Front terminals

	1SDA R1	
	3 poles	4 poles
T6N 630 Breaking unit	060327	060331
T6S 630 Breaking unit	060328	060332
T6H 630 Breaking unit	060329	060333
T6L 630 Breaking unit	060330	060334

T6 800 - F = Front terminals

	1SDA R1	
	3 poles	4 poles
T6N 800 Breaking unit	060335	060339
T6S 800 Breaking unit	060336	060340
T6H 800 Breaking unit	060337	060341
T6L 800 Breaking unit	060338	060342

T6 1000

	1SDA R1	
	3 poles	4 poles
T6N 1000 Breaking unit	060586	060590
T6S 1000 Breaking unit	060587	060591
T6H 1000 Breaking unit	060588	060592
T6L 1000 Breaking unit	060589	060593

Note: A type of terminal among ES - FC CuAl - R must necessarily be mounted on the 1000 A circuit-breaker.

Ordering codes

Trip units

1SDC210188F004



Trip units for T4

	In		1SDA R1			
			3 poles		4 poles	
					N= 50%	N= 100%
Thermomagnetic trip unit - TMD and TMA						
TMD 20-200	20	320	054651			054660
TMD 32-320	32	320	054652			054661
TMD 50-500	50	500	054653			054662
TMA 80-800	80	400...800	054654			054663
TMA 100-1000	100	500...1000	054655			054664
TMA 125-1250	125	625...1250	054656	054665		054671
TMA 160-1600	160	800...1600	054657	054666		054672
TMA 200-2000	200	1000...2000	054658	054667		054673
TMA 250-2500	250	1250...2500	054659	054668		054674

	In		1SDA R1			
			3 poles		4 poles	
Electronic trip unit						
PR221DS-LS/I	100		054603	054615		
PR221DS-LS/I	160		054604	054616		
PR221DS-LS/I	250		054605	054617		
PR221DS-LS/I	320		054627	054631		
PR221DS-I	100		054606	054618		
PR221DS-I	160		054607	054619		
PR221DS-I	250		054608	054620		
PR221DS-I	320		054628	054632		
PR222DS/P-LSI	100		054609	054621		
PR222DS/P-LSI	160		054610	054622		
PR222DS/P-LSI	250		054611	054623		
PR222DS/P-LSI	320		054629	054633		
PR222DS/P-LSIG	100		054612	054624		
PR222DS/P-LSIG	160		054613	054625		
PR222DS/P-LSIG	250		054614	054626		
PR222DS/P-LSIG	320		054630	054634		
PR222DS/PD-LSI	100		054635	054641		
PR222DS/PD-LSI	160		054636	054642		
PR222DS/PD-LSI	250		054637	054643		
PR222DS/PD-LSI	320		054647	054649		
PR222DS/PD-LSIG	100		054638	054644		
PR222DS/PD-LSIG	160		054639	054645		
PR222DS/PD-LSIG	250		054640	054646		
PR222DS/PD-LSIG	320		054648	054650		
PR223DS	160		059561	059562		
PR223DS	250		059563	059564		
PR223DS	320		059565	059566		

	In		1SDA R1			
			3 poles		4 poles	
Electronic trip unit for motor protection						
PR222MP	100		054688			
PR222MP	160		054689			
PR222MP	200		054690			

	In		1SDA R1			
			3 poles		4 poles	
					N= 50%	N= 100%
Magnetic only trip unit - MA						
MA 10-140	10	60...140	055077			055080
MA 25-350	25	150...350	055078			055081
MA 52-728	52	312...728	055079			055082
MA 80-1120	80	480...1120	054676			054682
MA 100-1400	100	600...1400	054677			054683
MA 125-1750	125	750...1750	054678	054684		
MA 160-2240	160	960...2240	054679	054685		
MA 200-2800	200	1200...2800	054680	054686		

see "Abbreviation caption" page 7/2

1SDC2101BPF004



Trip units for T5

		In	I₃	1SDA R1			
				3 poles	4 poles		
				N= 50%		N= 100%	
Thermomagnetic trip unit - TMA							
TMA 320-3200	320	1600...3200	054723	054725	054731		
TMA 400-4000	400	2000...4000	054724	054726	054732		
TMA 500-5000	500	2500...5000	054727	054729	054733		

		In	I₃	1SDA R1			
				3 poles	4 poles		
Thermomagnetic trip unit for generator protection - TMG							
TMG 320-1600	320	800...1600	055093	055101			
TMG 400-2000	400	1000...2000	055098	055102			
TMG 500-2500	500	1250...2500	055099	055103			

		In	1SDA R1				
				3 poles	4 poles		
Electronic trip unit							
PR221DS-LS/I	320		054691	054699			
PR221DS-LS/I	400		054692	054700			
PR221DS-LS/I	630		054707	055159			
PR221DS-I	320		054693	054701			
PR221DS-I	400		054694	054702			
PR221DS-I	630		054708	055160			
PR222DS/P-LSI	320		054695	054703			
PR222DS/P-LSI	400		054696	054704			
PR222DS/P-LSI	630		054709	055161			
PR222DS/P-LSIG	320		054697	054705			
PR222DS/P-LSIG	400		054698	054706			
PR222DS/P-LSIG	630		054710	055162			
PR222DS/PD-LSI	320		054711	054715			
PR222DS/PD-LSI	400		054712	054716			
PR222DS/PD-LSI	630		054719	054721			
PR222DS/PD-LSIG	320		054713	054717			
PR222DS/PD-LSIG	400		054714	054718			
PR222DS/PD-LSIG	630		054720	054722			
PR223DS	320		059567	059568			
PR223DS	400		059569	059570			
PR223DS	630		059571	059572			

		In	1SDA R1				
				3 poles			
Electronic trip unit for motor protection							
PR222MP	320		054735				
PR222MP	400		054736				

Ordering codes

Trip units

1SDC210B6R0001



Trip units for T6

				1SDA R1	
				3 poles	4 poles
				N= 50%	
				N= 100%	
Thermomagnetic trip unit - TMA					
TMA 630-6300	630	3150...6300	060347	060348	060472
TMA 800-8000	800	4000...8000	060349	060350	060473

				1SDA R1	
				3 poles	4 poles
Electronic trip unit					
PR221DS-LS/I	630		060351	060357	
PR221DS-LS/I	800		060363	060369	
PR221DS-LS/I	1000		060596	060602	
PR221DS-I	630		060352	060358	
PR221DS-I	800		060364	060370	
PR221DS-I	1000		060597	060603	
PR222DS/P-LSI	630		060353	060359	
PR222DS/P-LSI	800		060365	060371	
PR222DS/P-LSI	1000		060598	060604	
PR222DS/P-LSIG	630		060354	060360	
PR222DS/P-LSIG	800		060366	060372	
PR222DS/P-LSIG	1000		060599	060605	
PR222DS/PD-LSI	630		060355	060361	
PR222DS/PD-LSI	800		060367	060373	
PR222DS/PD-LSI	1000		060600	060606	
PR222DS/PD-LSIG	630		060356	060362	
PR222DS/PD-LSIG	800		060368	060374	
PR222DS/PD-LSIG	1000		060601	060607	
PR223DS	630		060376	060377	
PR223DS	800		060378	060379	
PR223DS	1000		060608	060609	

				1SDA R1	
				3 poles	
Electronic trip unit for motor protection					
PR222MP	630		060375		

Note: The releases for the T6 1000 A necessarily have to be fitted with the following types of terminal: EF - ES - FC CuAl - R.

Trip units for T7-T7M

				1SDA R1	
Electronic trip unit					
PR231/P-LS/I 3p ⁽¹⁾			063128		
PR231/P-I 3p ⁽¹⁾			063129		
PR231/P-LS/I 4p ⁽¹⁾			064179		
PR231/P-I 4p ⁽¹⁾			064180		
PR232/P-LSI			063130		
PR331/P-LSIG			063133		
PR332/P-LI			063134		
PR332/P-LSI			063135		
PR332/P-LSIG			063136		
PR332/P-LSIRc T7 ⁽²⁾			063137		
PR332/P-LSIRc T7M ⁽²⁾			064190		

Note: Loose trip units for T7-T7M are supplied without rating Plug. For T7-T7M in withdrawable version, sliding contact blocks for fixed and moving part are necessary. See page 3/4 and 7/43.

⁽¹⁾ To have the possibility to substitute PR231 with a different electronic trip unit, key plug must be ordered. Extra code for PR231 interchangeability 1SDA063140R1 must be specified.

⁽²⁾ RC protection can be obtained only with 1SDA063869R1 toroid.

see "Abbreviation caption" page 7/2

Ordering codes

Fixed parts, conversion kit and accessories for fixed parts

1SDC210197R0004



Plug-in (P) – Fixed part

F = Front terminals

	1SDA R1	
	3 poles	4 poles
T2 P FP F ⁽¹⁾	051329	051330
T3 P FP F ⁽²⁾	051331	051332

⁽¹⁾ For the circuit-breaker in plug-in version In max = 144 A

⁽²⁾ For the circuit-breaker in plug-in version In max = 225 A

EF = Front extended terminals

	1SDA R1	
	3 poles	4 poles
T4 P FP EF	054737	054740
T5 400 P FP EF	054749	054752
T5 630 P FP EF ⁽¹⁾	054762	054765

⁽¹⁾ For the circuit-breaker in plug-in version In max = 570 A

VR = Rear flat vertical terminals

	1SDA R1	
	3 poles	4 poles
T4 P FP VR	054738	054741
T5 400 P FP VR	054750	054753
T5 630 P FP VR ⁽¹⁾	054763	054766

⁽¹⁾ For the circuit-breaker in plug-in version In max = 570 A

HR = Rear flat horizontal terminals

	1SDA R1	
	3 poles	4 poles
T4 P FP HR	054739	054742
T5 400 P FP HR	054751	054754
T5 630 P FP HR ⁽¹⁾	054764	054767

⁽¹⁾ For the circuit-breaker in plug-in version In max = 570 A

Fixed parts for T4 250 - T5 400 circuit-breakers at 1000 V AC

FC Cu = Front terminals for copper cables

	1SDA R1	
	3 poles	4 poles
T4 250 P FP 1000 V AC	063458	063459
T5 400 P FP 1000 V AC	063462	063463

see "Abbreviation caption" page 7/2

Ordering codes

Fixed parts, conversion kit and accessories for fixed parts

1SDC210159F004



Withdrawable (W) – Fixed part

EF = Front extended terminals

	1SDA R1	
	3 poles	4 poles
T4 W FP EF	054743	054746
T5 400 W FP EF	054755	054758
T5 630 W FP EF ⁽¹⁾	054768	054771
T6 630/800 W FP EF	060384	060387
T7-T7M W FP EF	062045	062049

⁽¹⁾ For the circuit-breaker in the withdrawable version In max = 570 A

VR = Rear flat vertical terminals

	1SDA R1	
	3 poles	4 poles
T4 W FP VR	054744	054747
T5 400 W FP VR	054756	054759
T5 630 W FP VR ⁽¹⁾	054769	054772
T6 630/800 W FP VR	060386	060389

⁽¹⁾ For the circuit-breaker in the withdrawable version In max = 570 A

HR = Rear flat horizontal terminals

	1SDA R1	
	3 poles	4 poles
T4 W FP HR	054745	054748
T5 400 W FP HR	054757	054761
T5 630 W FP HR ⁽¹⁾	054770	054774
T6 630/800 W FP HR	060385	060388

⁽¹⁾ For the circuit-breaker in the withdrawable version In max = 570 A

HR/VR = Rear flat terminals

	1SDA R1	
	3 poles	4 poles
T7-T7M W FP HR	062044	062048

Note: Fixed parts of T7-T7M circuit-breaker with rear terminals are supplied as standard with terminals mounted horizontally. To order the terminals mounted vertically, the extra code 1SDA063571R1 must be specified.

1SDC210N9F000r



Fixed parts for T4 250 - T5 400 circuit-breakers at 1000V AC

FC Cu = Front terminals for copper cables

	1SDA R1	
	3 poles	4 poles
T4 250 W FP 1000 V AC	063460	063461
T5 400 W FP 1000 V AC	063464	063465

see "Abbreviation caption" page 7/2



Conversion of the version

Conversion kit from fixed into moving part of plug-in T2...T5

Type	1SDA.....R1	
	3 poles	4 poles
Kit P MP T2 ⁽¹⁾	051411	051412
Kit P MP T3 ⁽²⁾	051413	051414
Kit P MP T4	054839	054840
Kit P MP T5 400	054843	054844
Kit P MP T5 630 ⁽³⁾	054847	054848

Note: The plug-in version must be composed as follows
a) Fixed circuit-breaker
b) Conversion kit from fixed into moving part of plug-in
c) Fixed part of plug-in

⁽¹⁾ For the circuit-breaker in plug-in version In max = 144 A

⁽²⁾ For the circuit-breaker in plug-in version In max = 225 A

⁽³⁾ For the circuit-breaker in plug-in version In max = 570 A

Conversion kit from fixed into moving part of withdrawable T4...T7

Type	1SDA.....R1	
	3 poles	4 poles
Kit W MP T4	054841	054842
Kit W MP T5 400	054845	054846
Kit W MP T5 630 ⁽¹⁾	054849	054850
Kit W MP T6 630/800	060390	060391
Kit W MP T7-T7M	062162	062163

Note: The withdrawable version must be composed as follows
a) Fixed circuit-breaker
b) Conversion kit from fixed into moving part of withdrawable
c) Fixed part of withdrawable
d) Front for lever operating mechanism or rotary handle or motor operator (only T4, T5 and T6)
e) Sliding contacts blocks if the circuit-breaker is automatic or fitted with electrical accessories (only for T7)

⁽¹⁾ For the circuit-breakers in withdrawable version In max = 570 A.

Sliding contacts blocks for T7

Type	1SDA.....R1
Lef block - MP T7 - T7M	062164
Central block - MP T7 - T7M	062165
Right block - MP T7 - T7M	062166
Left block - FP T7	063572
Left block - FP T7M	062167
Central block - FP T7 - T7M	062168
Right block - FP T7 - T7M	062169

Note: Moving part of a circuit-breaker fitted with electronic accessories or PR331/P and PR332/P electronic trip units is supplied as standard with blocks for the connection, while blocks for fixed part must always be ordered.

Conversion kit from fixed into plug-in for RC222 and RC223

Type	1SDA.....R1
	4 poles
Kit P MP RC T4	054851
Kit P MP RC T5 400	054852

see "Abbreviation caption" page 7/2

Ordering codes

Fixed parts, conversion kit and accessories for fixed parts

Conversion kit from plug-in into withdrawable for RC222 and RC223

Type	1SDA.....R1	
	3 poles	4 poles
Kit W MP RC T4-T5	055366	

Conversion kit from fixed part of plug-in into fixed part of withdrawable

Type	1SDA.....R1	
	3 poles	4 poles
Kit FP P in FP W T4	054854	
Kit FP P in FP W T5	054855	

Terminals for fixed parts T4...T7

Type	1SDA.....R1	
	3 pieces	4 pieces
Front extended terminals - EF		
EF T6	013984	013985
EF T7-T7M	062171	062172
Front extended spread terminals - ES		
ES T5 (630 A)	055271	055272
ES T7-T7M	065620	065621
Front terminals for copper cables - FC Cu		
FC Cu T4 1x185mm ²	054831	054832
FC Cu T5 1x240mm ²	054833	054834
Front terminals for copper-aluminium cables - FC CuAl		
FC CuAl T4 1x185mm ²	054835	054836
FC CuAl T5 1x240mm ²	054837	054838
Rear flat vertical terminals - VR		
VR T6	013988	013989
Rear flat horizontal terminals - HR		
HR T6	013986	013987
Rear flat terminals - HR/VR		
HR/VR T7-T7M	063089	063090
Rear spread terminals - RS		
RS T7-T7M	063577	063578

Note: The FC Cu and FC CuAl terminals are supplied with insulating terminal covers for TC-FP fixed parts.

Lock for fixed part of withdrawable circuit-breaker

Type	1SDA.....R1	
	T4-T5-T6	
KLF-D FP - Different key for each circuit-breaker	055230	
KLF-S FP - Same key for different groups of circuit-breakers	055231	
PLL FP - Lock padlocks	055232	
KLF-D Ronis FP - Lock type Ronis	055233	

Terminal covers for fixed part - TC-FP

Type	1SDA.....R1	
	3 poles	4 poles
TC-FP T4	054857	054858
TC-FP T5	054859	054861

1SDC210N72F0001



1SDC210N73F0001



1SDC210N74F0001



Ordering codes

Accessories



1SDC21020AF0004

T4 - T5 - T6



1SDC210N75F0001

T7



1SDC210P07F0001



1SDC210N75F0001

Service releases

Shunt opening release - SOR

Type	1SDA.....R1		
	T1-T2-T3	T4-T5-T6	T7-T7M
uncabled version			
SOR 12 V DC	053000	054862	
SOR 24 V AC / DC			062065
SOR 24...30 V AC / DC	051333	054863	
SOR 30 V AC / DC			062066
SOR 48 V AC / DC			062067
SOR 48...60 V AC / DC	051334	054864	
SOR 60 V AC / DC			062068
SOR 110...120 V AC / DC			062069
SOR 110...127 V AC - 110...125 V DC	051335	054865	
SOR 120...127 V AC / DC			063547
SOR 220...240 V AC / DC			063548
SOR 220...240 V AC - 220...250 V DC	051336	054866	
SOR 240...250 V AC / DC			062070
SOR 380...400 V AC			062071
SOR 380...440 V AC	051337	054867	
SOR 415...440 V AC			062072
SOR 480...525 V AC	051338	054868	
cabled version⁽¹⁾			
SOR-C 12 V DC	053001	054869	
SOR-C 24...30 V AC / DC	051339	054870	
SOR-C 48...60 V AC / DC	051340	054871	
SOR-C 110...127 V AC - 110...125 V DC	051341	054872	
SOR-C 220...240 V AC - 220...250 V DC	051342	054873	
SOR-C 380...440 V AC	051343	054874	
SOR-C 480...525 V AC	051344	054875	

Note: For T7-T7M in withdrawable version, sliding contact blocks for fixed and moving part are necessary. See page 3/4 and 7/43.

⁽¹⁾ Compulsory with T4-T5-T6 in the withdrawable or motorized versions.

SOR Test Unit

Type	1SDA.....R1
T7-T7M	050228

Shunt closing release - SCR

Type	1SDA.....R1	
	T7M	
cabled version		
SCR 24 V AC / DC	062076	
SCR 30 V AC / DC	062077	
SCR 48 V AC / DC	062078	
SCR 60 V AC / DC	062079	
SCR 110...120 V AC / DC	062080	
SCR 120...127 V AC / DC	063549	
SCR 220...240 V AC / DC	063550	
SCR 240...250 V AC / DC	062081	
SCR 380...400 V AC	062082	
SCR 415...440 V AC	062083	

Note: For T7-T7M in withdrawable version, sliding contact blocks for fixed and moving part are necessary. See page 3/4 and 7/43.

see "Abbreviation caption" page 7/2

Ordering codes

Accessories



T4 - T5 - T6



T7

Undervoltage release - UVR

Type	1SDA.....R1		
	T1-T2-T3	T4-T5-T6	T7-T7M
uncabled version			
UVR 24 V AC / DC			062087
UVR 24...30 V AC / DC	051345	054880	
UVR 30 V AC / DC			062088
UVR 48 V AC / DC	051346	054881	062089
UVR 60 V AC/DC	052333	054882	062090
UVR 110...120 V AC / DC			062091
UVR 110...127 V AC - 110...125 V DC	051347	054883	
UVR 120...127 V AC / DC			063551
UVR 220...240 V AC / DC			063552
UVR 220...240 V AC - 220...250 V DC	051348	054884	
UVR 240...250 V AC / DC			062092
UVR 380...400 V AC			062093
UVR 380...440 V AC	051349	054885	
UVR 415...440 V AC			062094
UVR 480...525 V AC	051350	054886	
cabled version⁽¹⁾			
UVR-C 24...30 V AC / DC	051351	054887	
UVR-C 48 V AC / DC	051352	054888	
UVR-C 60 V AC/DC	052335	054889	
UVR-C 110...127 V AC - 110...125 V DC	051353	054890	
UVR-C 220...240 V AC - 220...250 V DC	051354	054891	
UVR-C 380...440 V AC	051355	054892	
UVR-C 480...525 V AC	051356	054893	

Note: For T7-T7M in withdrawable version, sliding contact blocks for fixed and moving part are necessary. See page 3/4 and 7/43.

⁽¹⁾ Compulsory with T4-T5-T6 in the withdrawable or motorized versions.

Shunt opening release with permanent operation - PS-SOR

Type	1SDA.....R1	
	T4-T5-T6	
uncabled version		
PS-SOR 24 V AC/DC	054876	
PS-SOR 110...120 V AC	054877	
cabled version		
PS-SOR-C 24 V AC/DC	054878	
PS-SOR-C 110...120 V AC	054879	

Connectors and socket-plugs for electrical accessories

Type	1SDA.....R1		
	T1-T2-T3	T4-T5-T6	
Socket-plug 12 poles	051362	051362	
Socket-plug 6 poles	051363	051363	
Socket-plug 3 poles	051364	051364	
3-way connector for second SOR-C		055273	

Loose cables

Type	1SDA.....R1	
	T1-T2-T3	
Kit 12 cables L=2m for AUX	051365	
Kit 6 cables L=2m for AUX	051366	
Kit 2 cables L=2m for SOR-UVR	051367	

see "Abbreviation caption" page 7/2



1SDC210147F004



T1 - T2 - T3



T7

Time delay device for undervoltage release - UVD

Type	1SDA.....R1	
	T1...T6	T7-T7M
UVD 24...30 V AC / DC	051357	038316
UVD 48 V AC / DC		038317
UVD 48...60 V AC / DC	051358	
UVD 60 V AC / DC		038318
UVD 110...125 V AC / DC	051360	038319
UVD 220...250 V AC / DC	051361	038320

Electrical signals

Auxiliary contacts - AUX

Type	1SDA.....R1			
	T1-T2-T3	T4-T5-T6	T7	T7M
uncabled version⁽¹⁾				
AUX 1Q 1SY 250 V AC/DC	051368	051368		
AUX 3Q 1SY 250 V AC/DC	051369	051369		
AUX 1Q 1SY 400 V AC			062104	
AUX 2Q 400 V AC			062102	062102
AUX 1Q 1SY 24 V DC		068797	062103	
AUX 3Q 1SY 24 V DC	054914	054914		
AUX 2Q 24 V DC			062101	062101
cabled version⁽¹⁾ with 1 m long cables				
AUX-C 1Q 1SY 250 V AC/DC	051370	054910		
AUX-C 3Q 1SY 250 V AC/DC	051371	054911		
AUX-C 1Q 1SY 400 V AC		054912		
AUX-C 2Q 400 V AC		054913		
AUX-C 1Q 1SY 24 V DC		066075		
AUX-C 3Q 1SY 24 V DC	055361	054915		
cabled version for T2 with PR221 DS trip unit				
AUX-C 1 S51 1Q SY	053704			
AUX-C 2Q 1SY	055504			
cabled contact for signalling trip coil release trip				
AUX-SA 1 S51 T4-T5 NO		055050		
AUX-SA 1 S51 T4-T5 NC		064518		
AUX-SA 1 S51 T6 ⁽²⁾		060393		
AUX-SA 1 S51 T7-T7M 24 V			066099	066100
AUX-SA 1 S51 T7-T7M 250 V			062105	063553
cabled contact for signalling manual/remote operation				
AUX-MO-C ⁽³⁾		054917		
cabled contact circuit breaker ready to close				
AUX-RTC 24 V DC				062108
AUX-RTC 250 V AC/DC				062109
cabled contact signalling spring charged				
AUX-MC 24 V DC				062106
AUX-MC 250 V AC/DC				062107
cabled contacts in electronic version				
AUX-E-C 1Q 1SY T4-T5 ⁽⁴⁾		054916		
AUX-E-C 1Q 1SY T6 ⁽⁴⁾		064161		

Note: For T7-T7M in withdrawable version, sliding contact blocks for fixed and moving part are necessary. See page 3/4 and 7/43.

⁽¹⁾ These cannot be combined with T2 circuit-breaker fitted with PR221DS electronic trip unit.

⁽²⁾ Available only mounted on the circuit-breaker.

⁽³⁾ For T4, T5 and T6 in plug-in/withdrawable version, it is necessary to order a socket plug connector 3 poles 1SDA051364R1

⁽⁴⁾ Only with circuit-breakers equipped with PR222DS/PD and PR223DS trip units.

Ordering codes

Accessories



Auxiliary position contacts - AUP

Type	1SDA.....R1		
	T2-T3	T4-T5-T6	T7-T7M
AUP T2-T3 - 1 contact signalling circuit-breakers racked-in	051372		
AUP-I T4-T5 24 V DC - 1 contact signalling circuit-breakers racked-in		054920	
AUP-I T4-T5 400 V AC/DC - 1 contact for signalling circuit-breakers racked-in		054918	
AUP-R T4-T5 24 V DC - 1 contact for signalling circuit-breakers racked-out		054921	
AUP-R T4-T5 400 V AC/DC - 1 contact for signalling circuit-breakers racked-out		054919	
AUP T7-T7M 24 V DC			062110
AUP T7-T7M 250 V AC			062111

Note: For T4-T5-T6 in withdrawable version, contacts signaling circuit-breaker racked-in. For T4-T5-T6 in plug-in version, contacts signaling circuit-breaker racked-in/racked-out.

Early auxiliary contacts - AUE

Type	1SDA.....R1			
	T1-T2-T3	T4-T5	T6	T7
AUE - early contacts	051374	054925	060394	062112

Note: On the T7, the anticipated auxiliary contacts (AUE) can only be ordered already installed on the circuit-breaker. For T7 in withdrawable version, sliding contact blocks for fixed and moving part are necessary. See page 3/4 and 7/43.

Adapters - ADP

Type	1SDA.....R1	
	T4-T5-T6	
ADP - Adapters 5pin	055173	
ADP - Adapters 6pin	054922	
ADP - Adapters 12pin	054923	
ADP - Adapters 10pin	054924	

Testing extension

Type	1SDA.....R1	
	T4-T5-T6	
5pin checking extension for blank tests on T4-T5-T6 P/W service releases	055351	
6pin checking extension for blank tests on T4-T5-T6 P/W auxiliary contacts (1+1) service and residual current releases	055063	
12pin checking extension for blank tests on T4-T5-T6 P/W auxiliary contacts (3+1)	055064	
10pin checking extension for blank tests on T4-T5-T6 P/W motor operator and early contacts	055065	

Trip reset

Type	1SDA.....R1	
	T7M	
Trip reset 24-30 V AC/DC	063554	
Trip reset 110-130 V AC/DC	062118	
Trip reset 200-240 V AC/DC	062119	

Note: For T7-T7M in withdrawable version, sliding contact blocks for fixed and moving part are necessary. See page 3/4 and 7/43.



Mechanical signals

Mechanical operation counter

Type	1SDA.....R1	
	T7M	
Mechanical operation counter	062160	



Motor operator

Solenoid operator - MOS

Type	1SDA.....R1	
	T1-T2-T3	
MOS 5 cables, superimposed 48...60 V DC	059596	
MOS 5 cables, superimposed 110...250 V AC/DC	059597	

Note: It is always fitted with crimped cables



MOS 5 cables T1-T2, side-by-side, 48...60 V DC	059598	
MOS 5 cables T1-T2, side-by-side, 110...250 V AC/DC	059599	

Note: It is always fitted with socket plug connector.



Stored energy motor operator - MOE

Type	1SDA.....R1		
	T4-T5		T6
MOE 24 V DC	054894		060395
MOE 48...60 V DC	054895		060396
MOE 110...125 V AC/DC	054896		060397
MOE 220...250 V AC/DC	054897		060398
MOE 380 V AC	054898		060399

Stored energy motor operator with electronics - MOE-E

Type	1SDA.....R1		
	T4-T5		T6
MOE-E 24 V DC	054899		060400
MOE-E 48...60 V DC	054900		060401
MOE-E 110...125 V AC/DC	054901		060402
MOE-E 220...250 V AC/DC	054902		060403
MOE-E 380 V AC	054903		060404

Note: Always supplied complete with the AUX-E-C electronic auxiliary contact.

Spring charging motor

Type	1SDA.....R1	
	T7M	
Spring charging motor 24...30 V AC/DC	062113	
Spring charging motor 48...60 V AC/DC	062114	
Spring charging motor 100...130 V AC/DC	062115	
Spring charging motor 220...250 V AC/DC	062116	
Spring charging motor 380...415 V AC	062117	

Note: For T7-T7M in withdrawable version, sliding contact blocks for fixed and moving part are necessary. See page 3/4 and 7/43.



Ordering codes

Accessories

Rotary handle operating mechanism

Direct- RHD

Type	1SDA.....R1				
	T1-T2-T3	T4-T5	T6	T7	
RHD normal for fixed and plug-in	051381	054926	060405	062120	
RHD_EM emergency for fixed and plug-in	051382	054927	060406	062121	
RHD normal for withdrawable		054928	060407	062120	
RHD_EM di emergency for withdrawable		055234	060408	062121	

Transmitted - RHE

Type	1SDA.....R1				
	T1-T2-T3	T4-T5	T6	T7	
RHE normal for fixed and plug-in	051383	054929	060409	062122	
RHE_EM emergency for fixed and plug-in	051384	054930	060410	062123	
RHE normal for withdrawable		054933	060411	062122	
RHE_EM di emergency for withdrawable		054934	060412	062123	
Individual components					
RHE_B just base for RHE for fixed and plug-in	051385	054931	060413	062124	
RHE_B just base for RHE withdrawable		054935	060414	062124	
RHE_S just rod 500mm for RHE	051386	054932	054932	064104	
RHE_H just handle for RHE	051387	054936	060415	062125	
RHE_H_EM just emergency handle for RHE	051388	054937	060416	062126	

IP54 protection for rotary handle

Type	1SDA.....R1		
	T1-T2-T3	T4-T5-T6	T7
RHE_IP54 protection kit IP54	051392	054938	054938

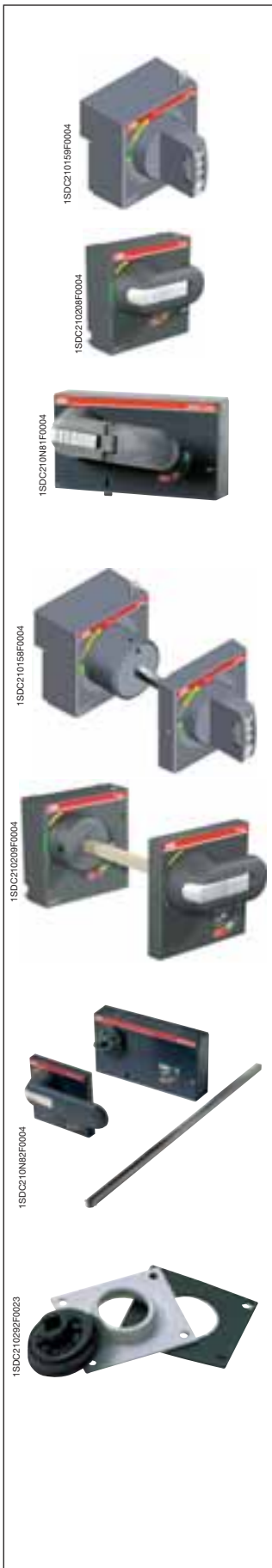



Operating mechanism and locks

Padlock lever lock - PLL

Type	1SDA.....R1		
	T1-T2-T3	T7	T7M
PLL - plug-in in open position	051393		
PLL for T1 1p - plug-in in open position	060199		
PLL - plate in open/closed position	051394		
PLL - plate in open position	060534		
PLL - padlock in open position		062150	062151

Note: On T7, the padlock is an alternative to the key lock

“Ronis” key lock in open position on the circuit-breaker - KLC ⁽¹⁾

Type	1SDA.....R1	
	T1-T2-T3	
standard version		
KLC same key - T1	053528	
KLC same key - T2	053529	
KLC same key - T3	053530	
version with key removable in both positions		
KLC-S same key - T1	051395	
KLC-S same key - T2	052015	
KLC-S same key - T3	052016	

⁽¹⁾ It cannot be mounted when there is a front operating mechanism, a rotary handle operating mechanism, motor operator or RC221/RC222 residual current device and, only in the case of three pole circuit-breakers, with the service releases (UVR, SOR).

Key lock in open position on the circuit-breaker - KLC

Type	1SDA.....R1	
	T7	T7M
KLC-D - different key	062134	062141
KLC-S - same key for different groups of circuit-breakers (N. 20005)	062135	062142
KLC-S - same key for different groups of circuit-breakers (N. 20006)	062136	062143
KLC-S - same key for different groups of circuit-breakers (N. 20007)	062137	062144
KLC-S - same key for different groups of circuit-breakers (N. 20008)	062138	062145
KLC-R - arrangement for Ronis key lock	062139	062146
KLC-P - arrangement for Profalux key lock	062140	062146

Key lock for rotary handle - RHL

Type	1SDA.....R1	
	T1-T2-T3	
RHL - different keys for each circuit-breaker/in open position	051389	
RHL - same key for different groups of circuit-breakers (N. 20005)	051390	
RHL - same key for different groups of circuit-breakers (N. 20006)	060147	
RHL - same key for different groups of circuit-breakers (N. 20007)	060148	
RHL - same key for different groups of circuit-breakers (N. 20008)	060149	
RHL - different keys for each circuit-breaker/in open-closed position	052021	

see “Abbreviation caption” page 7/2

Ordering codes

Accessories

Key lock for front/rotary handle - KLF

Type	1SDA.....R1		
	T4-T5	T6	T7
KLF-D - different key	054939	060658	063555
KLF-S - same key for different groups of circuit-breakers (N. 20005)	054940	060659	063556
KLF-S - same key for different groups of circuit-breakers (N. 20006)	054941	060660	063557
KLF-S - same key for different groups of circuit-breakers (N. 20007)	054942	060661	063558
KLF-S - same key for different groups of circuit-breakers (N. 20008)	054943	060662	063559
KLF-S - arrangement for Ronis key lock			063560
KLF-S - arrangement for Profalux key lock			063561

Key lock for motor operator - MOL

Type	1SDA.....R1	
	T4-T5	T6
MOL-D different key	054904	060611
MOL-S - same key for different groups of circuit-breakers (N. 20005)	054905	060612
MOL-S - same key for different groups of circuit-breakers (N. 20006)	054906	060613
MOL-S - same key for different groups of circuit-breakers (N. 20007)	054907	060614
MOL-S - same key for different groups of circuit-breakers (N. 20008)	054908	060615
MOL-M - lock only on manual operation with same key	054909	054909

Key lock in racked-in/test isolated/racked-out position

Type	1SDA.....R1	
	T7-T7M	
For 1 circuit-breaker - different key	062153	
For groups of circuit-breakers - same key (N. 20005)	062154	
For groups of circuit-breakers - same key (N. 20006)	062155	
For groups of circuit-breakers - same key (N. 20007)	062156	
For groups of circuit-breakers - same key (N. 20008)	062157	
Arrangement for Ronis key lock	063567	
Arrangement for Profalux key lock	063570	
Arrangement for Castell key lock	063568	
Arrangement for Kirk key lock	063569	

Note: The fixed part can be equipped with two different key locks.

Accessory for lock in racked-out position

Type	1SDA.....R1	
	T7-T7M	
Lock in racked-out position	062158	

Note: As optional in addition to the circuit-breaker lock in racked-in/isolated-test/racked-out position

1SDC210N8RF0004



1SDC210N8RF0004





1SDC210N87F0004



1SDC210210F0004

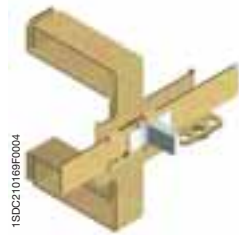

1SDC210169F0004



1SDC210373F0004

Mechanical compartment door lock

Type	1SDA.....R1	
	T7-T7M	
Mechanical compartment door lock with cables for T7-T7M ⁽¹⁾	062159	
Mechanical compartment door lock (fixing to wall) for T7-T7M F	063722	
Mechanical compartment door lock (fixing to floor) for T7-T7M F	063723	
Mechanical compartment door lock for T7-T7M W	063724	

Note: A circuit-breaker equipped with mechanical compartment door lock can not be interlocked with another circuit-breaker.

⁽¹⁾ To be ordered with cables kit for interlock and plate for interlock consistent with the circuit-breaker.

Front lever operating mechanism - FLD

Type	1SDA.....R1	
	T4-T5	T6
FLD - for fixed and plug-in	054944	060417
FLD - for withdrawable	054945	060418

Mechanical interlock - MIF

Type	1SDA.....R1	
	T1-T2-T3	
MIF front interlocking plate between 2 circuit-breakers	051396	
MIF front interlocking plate between 3 circuit-breakers	052165	

Mechanical interlock - MIR

Type	1SDA.....R1	
	T4-T5	
MIR-HB - frame unit horizontal interlock	054946	
MIR-VB - frame unit vertical interlock	054947	
MIR-P - plate for interlock type A T4 (F-P-W) + T4 (F-P-W)	054948	
MIR-P - plate for interlock type B T4 (F-P-W) + T5 400 (F-P-W) or T5 630 (F)	054949	
MIR-P - plate for interlock type C T4 (F-P-W) + T5 630 (P-W)	054950	
MIR-P - plate for interlock type D T5 400 (F-P-W) or T5 630 (F) + T5 400 (F-P-W) or T5 630 (F)	054951	
MIR-P - plate for interlock type E T5 400 (F-P-W) or T5 630 (F) + T5 630 (P-W)	054952	
MIR-P - plate for interlock type F T5 630 (P-W) + T5 630 (P-W)	054953	

Note: To interlock two circuit-breakers you have to order a frame unit interlock and a plate (for type A or B or C or D or E or F) interlock.

Mechanical interlock - MIR

Type	1SDA.....R1	
	T3	T6
Horizontal interlock	063324	060685
Vertical interlock	063325	060686

Ordering codes

Accessories



Mechanical interlock with cables between two circuit-breakers

Type	1SDA.....R1	
	T7-T7M	
Cables kit for interlock	062127	
Plate for fixed unit – floor fixed	062130	
Wiring kit for interlock with Emax	064568	
Plate for fixed unit – wall fixed	062129	
Plate for withdrawable cb	062131	
Shoulders for fixing to floor	063856	

Note: To interlock two circuit-breakers you have to order a cables kit and two plates in function of the version of the circuit-breaker.

Floor fixing plate

Type	1SDA.....R1	
	T7-T7M	
Floor fixing plate for fixed unit	063856	

Sealable lock of thermal adjustment

Type	1SDA.....R1	
	T1-T2-T3	
TMD release anti-adjustment seal	051397	

Transparent protection for buttons

Type	1SDA.....R1	
	T7M	
Transparent protection for buttons	062132	
Transparent protection for buttons - independent	062133	

IP54 door protection

Type	1SDA.....R1	
	T7M	
IP54 door protection	062161	

Residual current releases

SACE RC221, SACE RC222, SACE RC223

Type	1SDA.....R1		
	3 poles		4 poles
RC222/1 MOD 200 mm for T1			053869
RC221/1 for T1	051398		051401
RC222/1 for T1	051400		051402
RC221/2 for T2	051403		051405
RC222/2 for T2	051404		051406
RC221/3 for T3	051407		051409
RC222/3 for T3	051408		051410
RC223/3 for T3			064302
RC222/4 for T4			054954
RC223/4 for T4 250			054956
RC222/5 for T5			054955

Note: The residual current releases for the T2 and T3 circuit-breakers, except for the RC for T3, are always supplied complete with FC Cu terminal kits.



1SDC210172F0004

SACE RCQ

Type	1SDA.....R1	
	T1...T7-T7M	
Relay and closed toroid - diameter 60 mm	037388	
Relay and closed toroid - diameter 110 mm	037389	
Relay and closed toroid - diameter 185 mm	050542	
Relay and toroid which can be opened - diameter 110 mm	037390	
Relay and toroid which can be opened - diameter 180 mm	037391	
Relay and toroid which can be opened - diameter 230 mm	037392	
Relay only	037393	
Closed toroid only - diameter 60 mm	037394	
Closed toroid only - diameter 110 mm	037395	
Closed toroid only - diameter 185 mm	050543	
Toroid which can be opened - diameter 110 mm	037396	
Toroid which can be opened - diameter 180 mm	037397	
Toroid which can be opened - diameter 230 mm	037398	

Note: Opening coil and undervoltage coil to be ordered separately.

Installation accessories

Bracket for fixing onto DIN rail



1SDC210172F0004

Type	1SDA.....R1	
	T1-T2-T3	
DIN50022 T1-T2	051437	
DIN50022 T3	051439	
DIN 50022 T1 - T2 for RC221/RC222	051937	
DIN 50022 T3 for RC221/RC222	051938	
DIN 50022 T1 -T2 for MOS side-by-side	051939	
DIN 50022 T1 for RC222 mod. 200 mm	053940	

Connections terminals

High insulating terminal covers - HTC



1SDC210124F0004

Type	1SDA.....R1	
	3 poles	4 poles
HTC T1	051415	051416
HTC T2	051417	051418
HTC T3	051419	051420
HTC T4	054958	054959
HTC T5	054960	054961
HTC T6	014040	014041
HTC T7-T7M	063091	063092

Protection for high insulating terminal covers - HTC-P

Type	1SDA.....R1	
	3 poles	4 poles
HTC-P T4	054962	054963
HTC-P T5	054964	054965

Ordering codes

Accessories



1SDC210128F004

Low insulating terminal covers - LTC

Type	1SDA.....R1	
	3 poles	4 poles
LTC T1	051421	051422
LTC T2	051423	051424
LTC T3	051425	051426
LTC T4	054966	054967
LTC T5	054968	054969
LTC T6	014038	014039
LTC T7-T7M F	063093	063094

IP40 front protections for screw terminals - STC

Type	1SDA.....R1	
	3 poles	4 poles
STC T1	051431	051432
STC T2	051433	051434
STC T3	051435	051436



1SDC210127F004

Sealable screws for terminal covers

Type	1SDA.....R1	
	T1-T2-T3-T4-T5	T6-T7-T7M
Sealable screws	051504	013699



1SDC210203F004

Separating partitions - PB

Type	1SDA.....R1			
	T1-T2-T3	T4-T5	T6	T7-T7M
PB100 low (H=100 mm) - 4 pieces - 3p	051427	054970	050696	054970
PB100 low (H=100 mm) - 6 pieces - 4p	051428	054971	050697	054971
PB200 high (H=200 mm) - 4 pieces - 3p	051429	054972		054972
PB200 high (H=200 mm) - 6 pieces - 4p	051430	054973		054973



1SDC210394F004

Front extended terminals - EF

Type	1SDA.....R1			
	3 pieces	4 pieces	6 pieces	8 pieces
EF T1	051442	051443	051440	051441
EF T2	051466	051467	051464	051465
EF T3	051490	051491	051488	051489
EF T4	055000	055001	054998	054999
EF T5	055036	055037	055034	055035
EF T6 630	023379	023389	013920	013921
EF T6 800	023383	023393	013954	013955
EF T6 1000	064319	064320	064321	064322
EF T7-T7M	063103	063104	063105	063106

see "Abbreviation caption" page 7/2



1SDC210391F0004



1SDC210392F0004

Front terminals for copper-aluminium cables - FC CuAl

Type	1SDA.....R1			
	3 pieces	4 pieces	6 pieces	8 pieces
FC CuAl T1 50mm ² - external terminal	064186	064187	064188	064189
FC CuAl T1 95mm ² - external terminal	051446	051447	051444	051445
FC CuAl T2 95mm ²	051458	051459	051456	051457
FC CuAl T2 2x95mm ² - external terminal	055153	055154	055151	055152
FC CuAl T2 185mm ² - external terminal	051462	051463	051460	051461
FC CuAl T3 2x150mm ² - external terminal	055157	055158	055155	055156
FC CuAl T3 185mm ²	051486	051487	051484	051485
FC CuAl T3 150...240mm ² - external terminal	051940	051941	051942	051943
FC CuAl T4 1x50mm ²	054984	054985	054982	054983
FC CuAl T4 2x150mm ² - external terminal	054992	054993	054990	054991
FC CuAl T4 1x185mm ²	054988	054989	054986	054987
FC CuAl T4 1x240mm ² - external terminal	064549	064550	064551	064552
FC CuAl T5 400 2x120mm ² - external terminal	055028	055029	055026	055027
FC CuAl T5 400 1x240mm ²	055020	055021	055018	055019
FC CuAl T5 400 1x300mm ²	055024	055025	055022	055023
FC CuAl T5 2x240mm ² - external terminal	055032	055033	055030	055031
FC CuAl T6 630 2x240mm ²	023380	023390	013922	013923
FC CuAl T6 800 3x185mm ² - external terminal	023384	023394	013956	013957
FC CuAl T6 1000 4x150mm ² - external terminal	060687	060688	060689	060690
FC CuAl T7 1250-T7M 630 2x240mm ² - external terminal	063865	063866	063867	063868
FC CuAl T7 1250-T7M 1250 4x240mm ² - external terminal	063112	063113	063114	063115

Front terminals - F ⁽¹⁾

Type	1SDA.....R1			
	3 pieces	4 pieces	6 pieces	8 pieces
F T2 - Plugs with screws	051450	051451	051448	051449
F T3 - Plugs with screws	051478	051479	051476	051477
F T4 - Plugs with screws	054976	054977	054974	054975
F T5 - Plugs with screws	055012	055013	055010	055011
F T6 630-800 - Plugs with screws	060421	060422	060423	060424
F T7-T7M - Plugs with screws	063099	063100	063101	063102

⁽¹⁾ To be requested as loose kit

Front extended spread terminals - ES

Type	1SDA.....R1			
	3 pieces	4 pieces	6 pieces	8 pieces
ES T2	051470	051471	051468	051469
ES T3	051494	051495	051492	051493
ES T4	055004	055005	055002	055003
ES T5	055040	055041	055038	055039
ES T6 (1/2 upper kit)	050692			
ES T6 (1/2 lower kit)	050704			
ES T6		050693	050688	050689
ES T7-T7M (1/2 upper kit)	063107			
ES T7-T7M (1/2 lower kit)	063108			
ES T7-T7M		063109	063110	063111



1SDC210387F0004



1SDC210385F0004

Ordering codes

Accessories

1SDC210389F0004



Front terminals for copper cables - FC Cu

Type	1SDA.....R1			
	3 pieces	4 pieces	6 pieces	8 pieces
FC Cu T2	051454	051455	051452	051453
FC Cu T3	051482	051483	051480	051481
FC Cu T4 1x185mm ²	054980	054981	054978	054979
FC Cu T5 400 1x240mm ²	055016	055017	055014	055015
FC Cu T5 630 2x240mm ²	055364	055365	055362	055363

Rear terminals for copper-aluminium cables - RC CuAl

Type	1SDA.....R1			
	3 pieces	4 pieces	6 pieces	8 pieces
RC CuAl T6 630 2x240mm ²	023381	023391	013924	013925
RC CuAl T6 800 3x185mm ²	023385	023395	013958	013959

Note: For ordering methods, please ask ABB SACE.

1SDC210389F0004



Front multi-cable terminals - MC

Type	1SDA.....R1			
	3 pieces	4 pieces	6 pieces	8 pieces
MC CuAl T4 6x35mm ²	054996	054997	054994	054995
MC CuAl T5 6x50mm ²	064182	064183	064184	064185

1SDC210C59F0001



Rear terminals

Type	1SDA.....R1			
	3 pieces	4 pieces	6 pieces	8 pieces
R T2	051474	051475	051472	051473
R T3	051498	051499	051496	051497
R T4	055008	055009	055006	055007
R T5	055044	055045	055042	055043
R T6	060425	060426	060427	060428
R T7	063116	063117	063118	063119

1SDC210N91F0004



Rear flat horizontal terminals - HR

Type	1SDA.....R1			
	3 pieces	4 pieces	6 pieces	8 pieces
HR T7-T7M	063120	063121	063122	063123

1SDC210N92F0004



Rear flat vertical terminals - VR

Type	1SDA.....R1			
	3 pieces	4 pieces	6 pieces	8 pieces
VR T7-T7M	063124	063125	063126	063127

Rear flat horizontal terminals - HR

Type	1SDA.....R1			
	3 pieces	4 pieces	6 pieces	8 pieces
HR T1	053865	053866	053867	053868
HR RC221/222 T1		053987		

see "Abbreviation caption" page 7/2



1SDC210989F0004

Kit for taking up voltage for auxiliaries

Type	1SDA.....R1	
	3 pieces	4 pieces
AuxV T2 FC Cu	051500	051501
AuxV T3 FC Cu	051502	051503
AuxV T4 FC Cu	055046	055047
AuxV T4-T5 F	055048	055049

Note: Only available for fixed version circuit-breaker.

Front display unit - FDU

Type	1SDA.....R1	
	T4-T5	T6
FDU display unit with PR222 or PR223	055051	060429

Automatic transfer switch - ATS010

Type	1SDA.....R1
ATS010 for T4, T5, T6, T7 and T7M	052927

HMI030 interface on the front of switchgear

Type	1SDA.....R1	
	T4...T7-T7M	
HMI030 interface on the front of switchgear	063143	

Note: It can be used with circuit-breaker equipped with PR222DS/PD, PR223EF, PR223DS, PR331/P and PR332/P trip units.

Modules for PR33x electronic trip unit

Type	1SDA.....R1	
	T7	T7M
PR330/V + internal voltage socket ⁽¹⁾	063144	063574
PR330/V + external voltage socket ⁽¹⁾	069126	069127
PR330/D-M communication module (Modbus RTU)	063145	063145
PR330/R actuator module	063146	063146
BT030 external wireless communication module	058259	058259
PR030B power supply unit	058258	058258
Arrangement for internal voltage socket for PR332/P with PR330/V module ⁽¹⁾	063573	063573
Extracode for external voltage socket for PR332/P LSIRC	069128	069128

⁽¹⁾ Can be ordered only mounted on the circuit-breakers. See page 3/42.

Dialogue unit PR222DS/PD

Type	1SDA.....R1	
	T4-T5-T6	
LSI	055066	
LSIG	055067	

Note: To be specified only in addition to the code of the automatic circuit-breaker, with analogous overcurrent release (PR222DS/P). To order the trip unit separately, see pag 7/38.



1SDC210N83F0004

1SDC210N84F0004

1SDC210N85F0004

1SDC210N86F0004

1SDC210N87F0004

1SDC210N88F0004

Ordering codes

Accessories

1SDC210N98F004

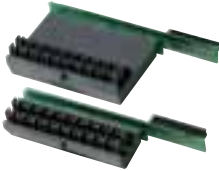

Extracode for PR231 interchangeability

Type	1SDA.....R1	
	T7	T7M
Extracode for PR231 interchangeability	063140	

Note: In order to replace the PR231 with another electronic trip unit, the key-plug must be ordered. The extra-code 1SDA063140R1 for the interchangeability of the PR231 trip unit must be specified.

Trip unit adapters for PR33x

Type	1SDA.....R1	
	T7	T7M
Adapters for PR331-PR332	063141	
Adapters for PR33x		063142

Note: Always provided with the circuit-breaker.

CT for external neutral

Type	1SDA.....R1	
CT for external neutral - T4 320	055055	
CT for external neutral - T4 250	055054	
CT for external neutral - T4 160	055053	
CT for external neutral - T4 100	055052	
CT for external neutral - T5 400	055057	
CT for external neutral - T5 320	055056	
CT for external neutral - T5 630	055058	
CT for external neutral - T6 630	060430	
CT for external neutral - T6 800	060431	
CT for external neutral - T6 1000	060610	

Note: Connector X4 is not included and must be ordered separately.

Current sensor for external neutral

Type	1SDA.....R1	
Current sensor for external neutral - T7-T7M 400...1600	063159	

Rating plug

Type	1SDA.....R1	
	T7	T7M
In = 400 A	063147	
In = 630 A	063148	
In = 800 A	063149	
In = 1000 A	063150	
In = 1250 A	063151	
In = 1600 A	063152	
In = 400 A for RC protection ⁽¹⁾	063725	
In = 630 A for RC protection ⁽¹⁾	063726	
In = 800 A for RC protection ⁽¹⁾	063727	
In = 1000 A for RC protection ⁽¹⁾	063728	
In = 1250 A for RC protection ⁽¹⁾	063731	
In = 1600 A for RC protection ⁽¹⁾	063732	

⁽¹⁾ For PR332/P LSIRc, PR332/P LSIG with PR330/V and RC toroid.

1SDC210P01F004



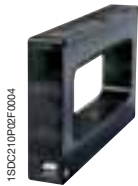

Extracode rating plug

Type	1SDA.....R1	
In = 400 A	063153	
In = 630 A	063154	
In = 800 A	063155	
In = 1000 A	063156	
In = 1250 A	063157	
In = 400 A for RC protection ⁽¹⁾	063733	
In = 630 A for RC protection ⁽¹⁾	063734	
In = 800 A for RC protection ⁽¹⁾	063735	
In = 1000 A for RC protection ⁽¹⁾	063736	
In = 1250 A for RC protection ⁽¹⁾	063737	
In = 1600 A for RC protection ⁽¹⁾	064288	

Note: To be specified only in addition to the code of the automatic circuit-breaker.

⁽¹⁾ For PR332/P LSIRc

Homopolar toroid for residual current protection

Type	1SDA.....R1	
	T7-T7M	
Toroid RC	063869	

Homopolar sensor for the earthing conductor of the main power supply

Type	1SDA.....R1	
	T7-T7M	
Sensor	059145	

Accessories for electronic trip units

Type	1SDA.....R1		
	T4-T5-T6	T7-T7M	
X3 Connector for fixed circuit-breaker PR222DS or PR223DS	055059		
X3 Connector for plug-in/withdrawable circuit-breaker	055061		
X4 Connector for fixed circuit-breaker	055060		
X4 Connector for plug-in/withdrawable circuit-breaker	055062		
TT1 - Test Unit ⁽¹⁾	037121		
TT1 - Test Unit for PR231/P, PR232/P electronic trip units		037121	
PR010/T - Test and configuration unit for PR222DS/P, PR222DS/PD, PR223DS, PR222MP electronic trip units	048964		
PR010/T - Test and configurator unit for PR33x and PR232 electronic trip unit		048964	
PR021/K - Signalling unit for PR222DS/PD, PR223DS, PR223EF, PR222MP, PR223EF, PR331 or PR332 electronic trip units	059146		
PR212/CI - Contactor control unit for PR222MP	050708		
EP010 - Interface module for PR222/PD	059469		
EP010 - Interface module for PR332/P electronic trip unit		060198	
EP010 - Interface module for PR223/DS	063166		
EP010 - Interface module for PR223EF	064515		
VM210 measurement module for PR223DS and PR223EF	059602		
SW210 Bus Switch for PR223EF	064269		

Note: For the use of X3 and X4 connectors, see page 3/44.

⁽¹⁾ Available also for T2.

see "Abbreviation caption" page 7/2

Ordering codes

Accessories

1SDC210P000004



Spare parts

Flanges for compartment door

Type	1SDA.....R1	
Flange for compartment door for T1-T2-T3	051509	
Flange for compartment door for MOS or RHD T1-T2-T3	051510	
Flange for compartment door T1 with RC221 or RC222 3p	051511	
Flange for compartment door T2 with RC221 or RC222 3p	051512	
Flange for compartment door T3 with RC221 or RC222 3p	051513	
Flange for compartment door T1-T2-T3 with RC221 or RC222 4p	051514	
Flange for compartment door for T4-T5 fixed or plug-in	055094	
Flange for compartment door for T4-T5 withdrawable	055095	
Flange for compartment door for RC222 for T4-T5	055096	
Flange for the T6 compartment door	060432	
Flange for the withdrawable T6 compartment door	060433	
Flange for the fixed T6 compartment door with MOE/MOE-E, RHD and FLD	060434	
Flange for compartment door for T7-T7M fixed	063160	
Flange for compartment door for T7-T7M withdrawable	063161	
Flange for compartment door for T7 fixed with rotary handle	063162	

Solenoid operator for residual current device

Type	1SDA.....R1	
RC221/RC222 for T1	051506	
RC221/RC222 for T2	051507	
RC221/RC222 for T3	051508	
RC223 for T3	064548	
RC222/RC223 for T4-T5	055097	

Connecting terminals for electrical accessories

Type	1SDA.....R1	
	T7-T7M	
Single terminal	062170	

Note: To have a complete overview of the spare parts available for the Tmax family of circuit-breakers, please consult the "Spare Parts Catalogue".

SD-View 2000 software

Type	1SDA.....R1	
SD-View 2000 software	060549	
SD-View 2000 software - 5000 tags license	060550	
SD-View 2000 software - 10000 tags license	060551	
SD-View 2000 software - 20000 tags license	064106	

see "Abbreviation caption" page 7/2

Notes

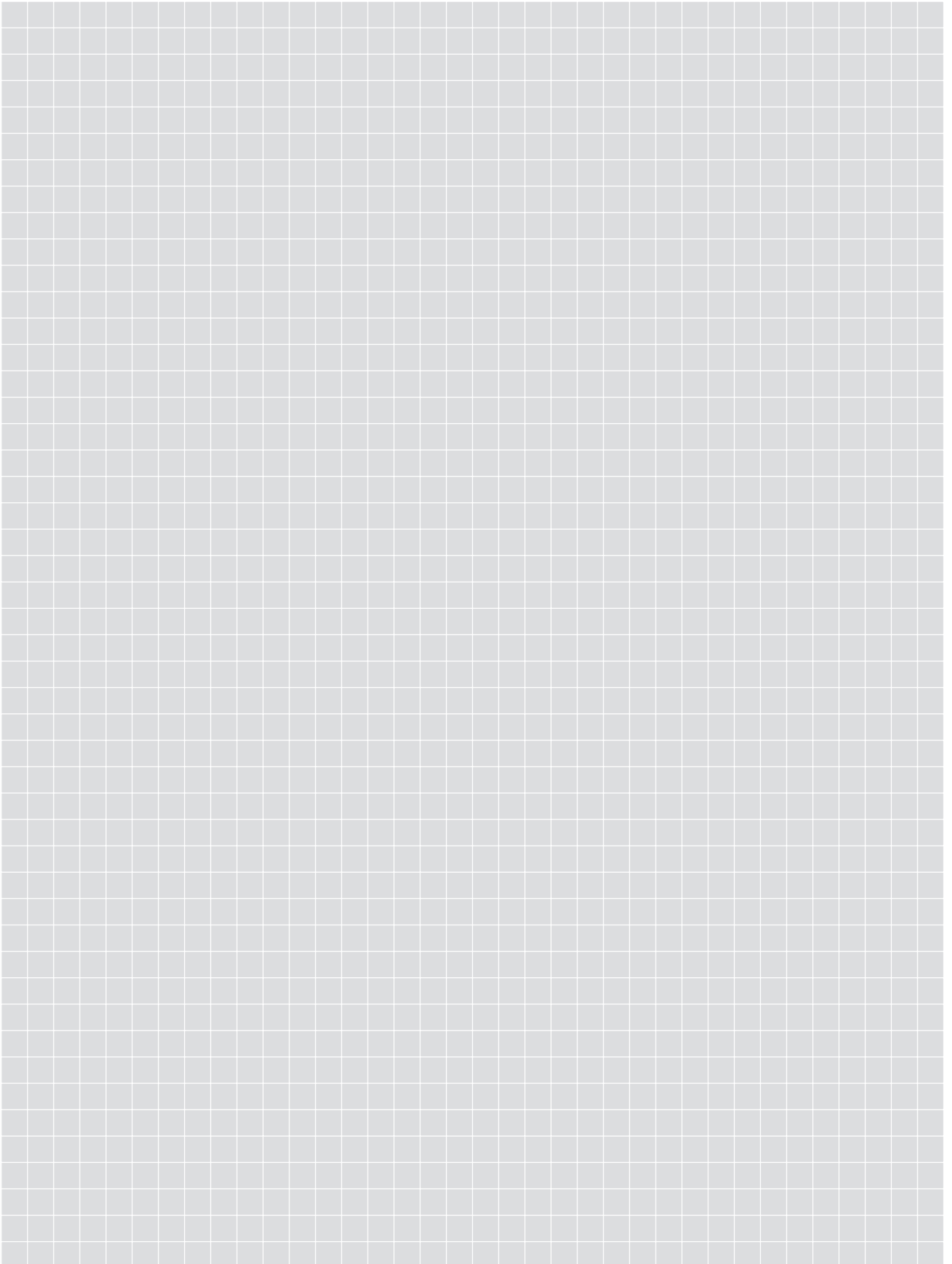

Notes

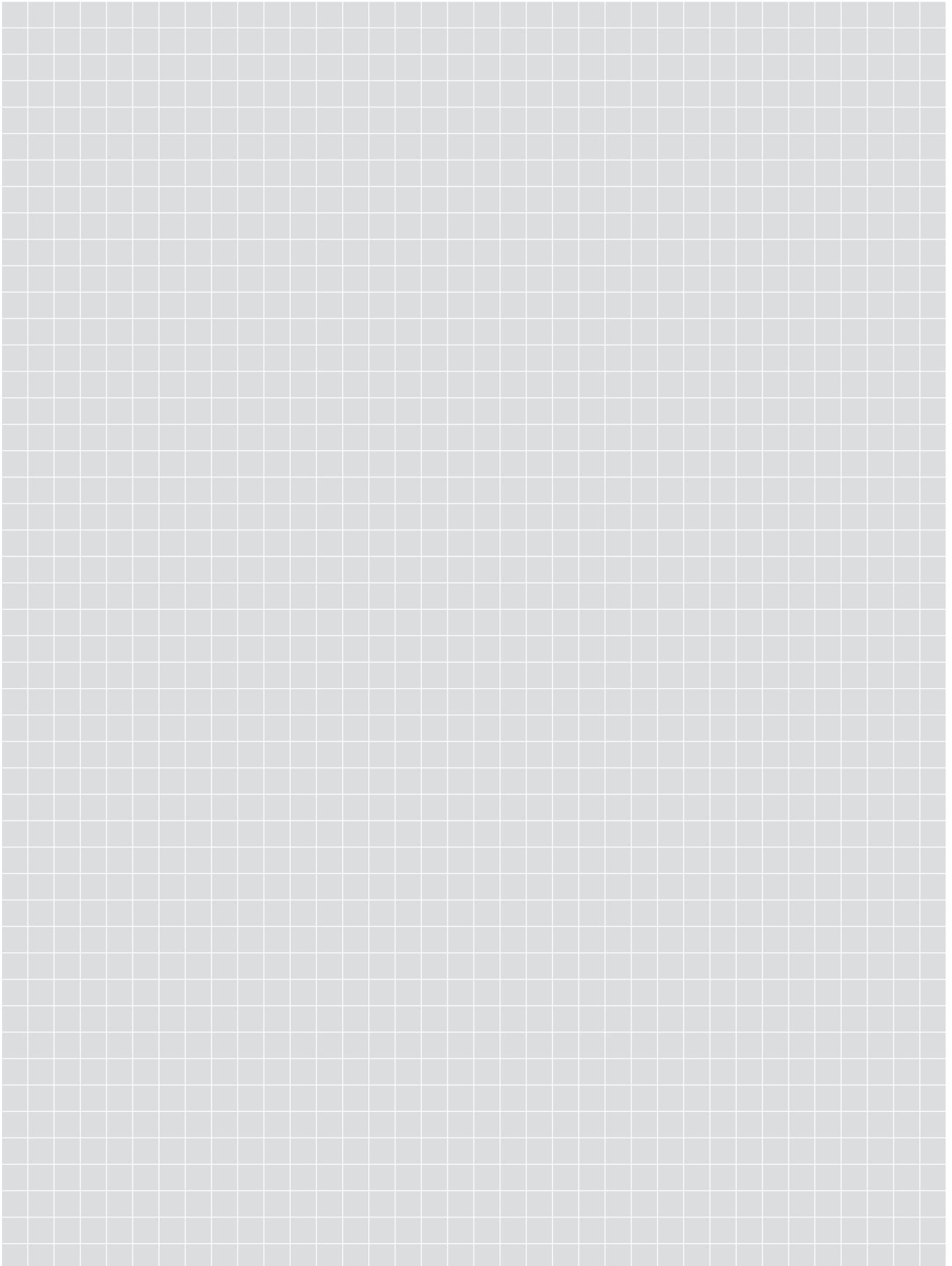

Notes

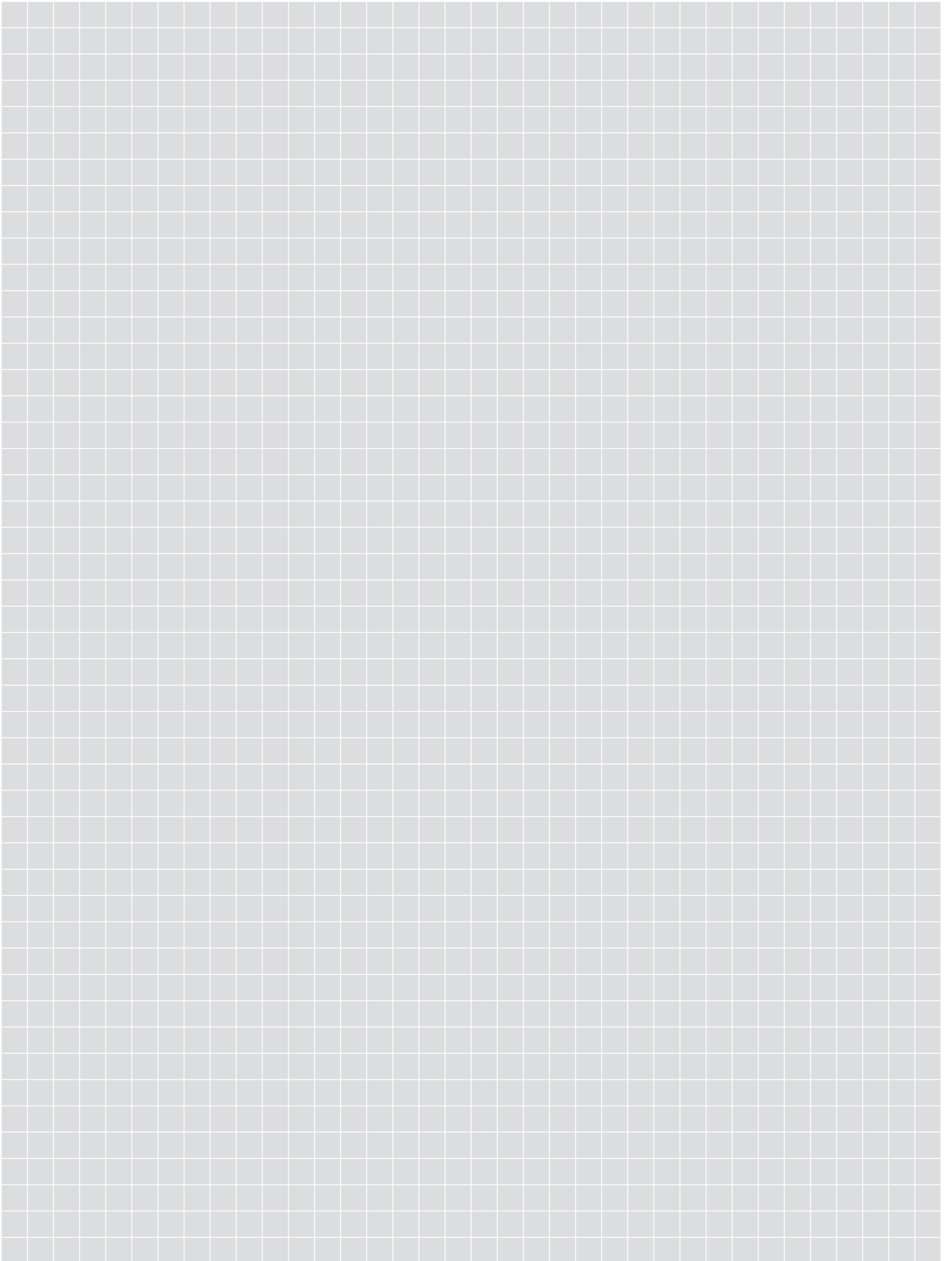

Notes

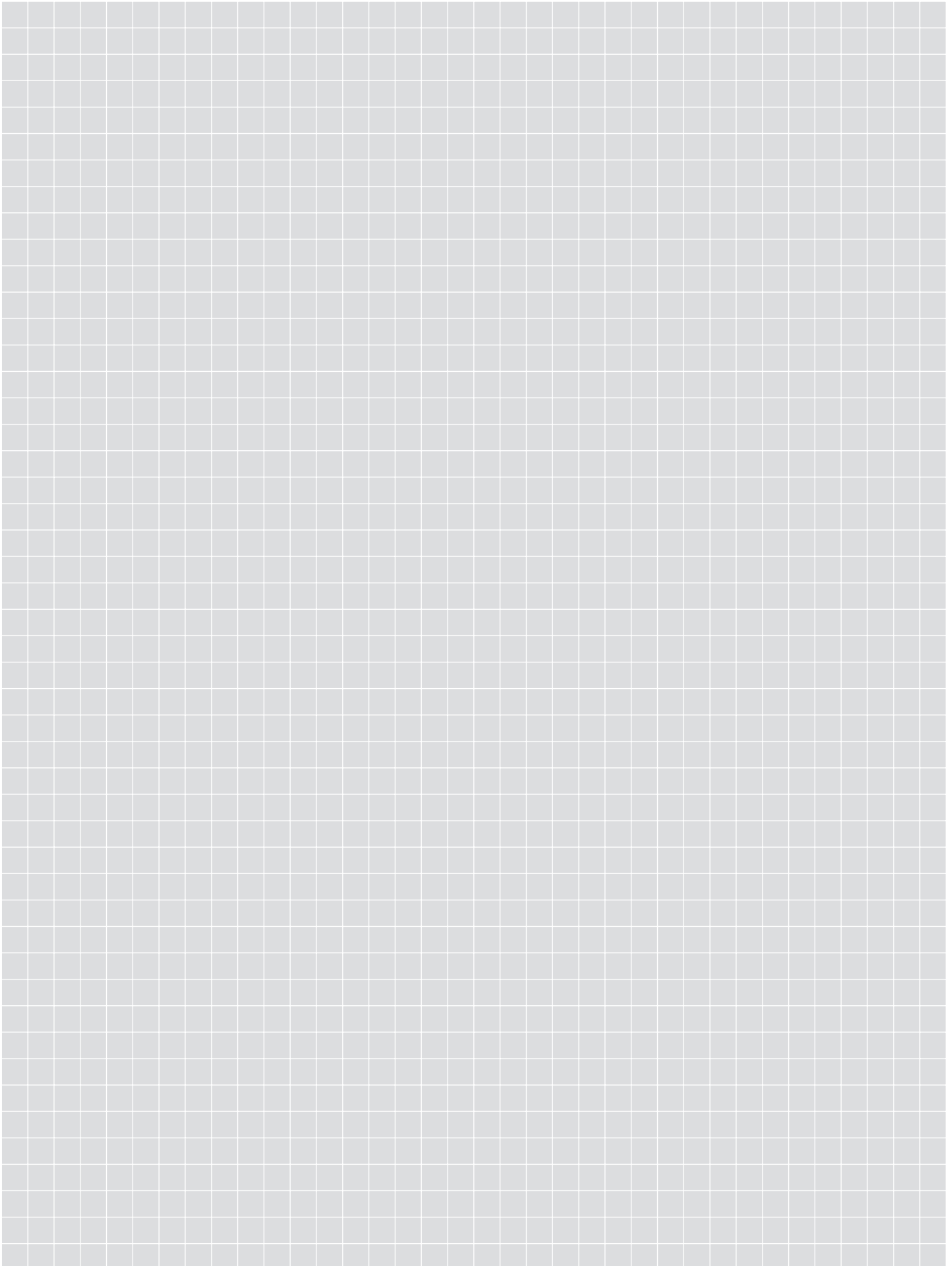

Contact us

ABB SACE

A division of ABB S.p.A.

L.V. Breakers

Via Baioni, 35

24123 Bergamo

Phone: +39 035.395.111

Fax: +39 035.395.306-433

www.abb.com

The data and illustrations are not binding. We reserve the right to modify the contents of this document on the basis of technical development of the product, without prior notice.

Copyright 2010 ABB. All rights reserved.

1SDC210015D0205 - 07/2010 - 6.000